

**TOWN OF MOUNTAIN VILLAGE  
REGULAR DESIGN REVIEW BOARD MEETING  
AGENDA**

**THURSDAY FEBRUARY 4, 2021 10:00 AM**

**MOUNTAIN VILLAGE TOWN HALL**

**455 MOUNTAIN VILLAGE BLVD, MOUNTAIN VILLAGE, COLORADO**

**TO BE HELD <https://us02web.zoom.us/j/81006771769?pwd=Y3lJUjc3Ym43dU1yRU1KMGIUdm1SZz09>**

**(see login details below)**

	Time	Min.	Presenter	Type	
1.	10:00		Chair		Call to Order
2.	10:00	5	Ward	Action	Reading and Approval the December 17, 2020 Special Meeting and January 7, 2021 Design Review Board Meeting Minutes.
3.	10:05	45	Miller Applicant	Quasi-Judicial	Consideration of a Design Review: Initial Architecture and Site Review for a new Single-Family residence on Lot BC513E, 104 Lawson Overlook, pursuant to CDC section 17.4.11. <b>This Item was continued from 01.07.2021.</b>
4.	10:50	60	Miller Applicant	Quasi-Judicial/ Review and Recommendation	Consideration of a Design Review: Initial Architecture and Site Review for a new Single-Family residence on Lot 165, Unit 6, 160 Cortina Drive, pursuant to CDC section 17.4.11. Concurrent review and recommendation to Town Council regarding a variance request for Building Height and Average Building Height pursuant to CDC section 17.4.16.
5.	11:50	45	Ward Applicant	Quasi-Judicial	Consideration of a Design Review: Initial Architecture and Site Review for a new single-family residence on Lot 729R-5, 91 Pennington Place, pursuant to CDC section 17.4.11.
6.	12:35	30			LUNCH (Recess)
7.	1:05	45	Miller Applicant	Quasi-Judicial	Consideration of a Design Review: Initial Architecture and Site Review for a new Detached Condominium Residence on Lot 161D-1, Unit 17, 8 Tunnel Lane (The Ridge), pursuant to CDC section 17.4.11.
8.	1:50	25	Miller Applicant	Review and Recommendation	A review and recommendation to Town Council regarding a Rezone and Density Transfer to rezone Blue Mesa Lodge (Lot 42B), Unit 23A from one (1) Efficiency Lodge zoning designation unit to one (1) Lodge zoning designation unit pursuant to CDC Sections 17.4.9 and 17.4.10
9.	2:15	15	Miller Applicant	Review and Recommendation	A review and recommendation to Town Council regarding a Rezone and Density Transfer to rezone Blue Mesa Lodge (Lot 42B), Unit 23B from one (1) Efficiency Lodge zoning designation unit to one (1) Lodge zoning designation unit pursuant to CDC Sections 17.4.9 and 17.4.10

Please note that this Agenda is subject to change. (Times are approximate and subject to change)

455 Mountain Village Blvd., Suite A, Mountain Village, Colorado 81435

Phone: (970) 369-8242

Fax: (970) 728-4342

Individuals with disabilities needing auxiliary aid(s) may request assistance by contacting Town Hall at the above numbers or email: [cd@mtnvillage.org](mailto:cd@mtnvillage.org). We would appreciate it if you would contact us at least 48 hours in advance of the scheduled event so arrangements can be made to locate requested auxiliary aid(s).

**DESIGN REVIEW BOARD MEETING  
AGENDA FOR FEBRUARY 4, 2021**

10.	2:30	25	Miller Applicant	Review and Recommendation	Review and Recommendation to Town Council regarding a Density Transfer and Rezone located at Lot 60RA, 650 Mountain Village Blvd #C, to rezone La Chamonix Unit C from one (1) Efficiency Lodge Zoning Designation to one (1) Lodge Zoning Designation pursuant to CDC Sections 17.4.9 and 17.4.10. <b>This item was continued from 3.26.2020, 5.7.2020, 6.4.2020, 7.2.2020, 8.6.2020, 9.3.2020, 10.1.2020, 11.5.2020, 12.3.2020.</b>
11.	2:55	5	Staff & Board	Discussion Action	Other Business: List of Design Review Board Members whose terms are up in April 2021 and request for letters of interest/resumes.
12.	3:00		Chair		Adjourn

**Topic: February 4, 2021 DRB Regular Meeting**  
**Time: Feb 4, 2021 10:00 AM Mountain Time (US and Canada)**

**Join Zoom Meeting**

<https://us02web.zoom.us/j/81006771769?pwd=Y3JJUjc3Ym43dU1yRU1KMGIUdm1SZz09>

**Dial by your location**

**+1 669 900 9128 US (San Jose)**

**+1 253 215 8782 US (Tacoma)**

**+1 346 248 7799 US (Houston)**

**+1 646 558 8656 US (New York)**

**+1 301 715 8592 US (Washington D.C)**

**+1 312 626 6799 US (Chicago)**

**Meeting ID: 810 0677 1769**

**Passcode: 075155**

**Find your local number: <https://us02web.zoom.us/j/81006771769>**

**Consistent with Resolution No. 2020-0514-10 regarding virtual (electronic) meetings, written testimony shall be submitted to [cd@mtnvillage.org](mailto:cd@mtnvillage.org) and must be received no later than 48 hours prior to the public hearing. Oral testimony, for those wishing to testify, must register by sending an email to [cd@mtnvillage.org](mailto:cd@mtnvillage.org) at least one hour prior to the agendized hearing.**

Please note that this Agenda is subject to change. (Times are approximate and subject to change)  
455 Mountain Village Blvd., Suite A, Mountain Village, Colorado 81435  
Phone: (970) 369-8242 Fax: (970) 728-4342

Individuals with disabilities needing auxiliary aid(s) may request assistance by contacting Town Hall at the above numbers or email: [cd@mtnvillage.org](mailto:cd@mtnvillage.org). We would appreciate it if you would contact us at least 48 hours in advance of the scheduled event so arrangements can be made to locate requested auxiliary aid(s).

**DESIGN REVIEW BOARD MINUTES  
TOWN OF MOUNTAIN VILLAGE  
DESIGN REVIEW BOARD MEETING  
THURSDAY JANUARY 7, 2021**

**Call to Order**

Chairman Banks Brown called the meeting of the Design Review Board (DRB) of the Town of Mountain Village to order at 10:01 AM on JANUARY 7, 2021, held remotely via ZOOM:  
<https://us02web.zoom.us/j/89815948201?pwd=OE82VVlGSDZZWnROREZ0SHQyYW9Mdz09>

**Attendance**

**The following Board members were present and acting:**

Banks Brown  
David Craige  
Greer Garner  
Cath Jett  
Ellen Kramer (1<sup>nd</sup> alternate)  
Scott Bennett (2<sup>nd</sup> alternate)

**The following Board members were absent:**

David Eckman  
Liz Caton  
Adam M

**Town Staff in attendance:**

Michelle Haynes, Planning & Development Services Director  
John Miller, Senior Planner  
Amy Ward, Planner

**Public in attendance:**

David Petty  
Dustin  
Jonas Lee  
Katherine Chia  
Furst  
Lorrie Denesik

**APPROVAL OF MINUTES**

On a **MOTION** by Jett **SECONDED** by Garner, the DRB approved the minutes dated December 3, 2020.

Correction Item 4 remove extra e

**AGENDA ITEM FOR CONTINUATION**

Staff requested the continuation of Agenda Item #3 to the February 4, 2021, Design Review Board (DRB) meeting. The following items were heard for the purposes of continuation and the Public Hearing was not opened.

On a **MOTION** made by Craige and **SECONDED** by Jett, the DRB voted unanimously to continue DRB Agenda Item #3 to the February 4, 2021 Regular DRB meeting

**AGENDA ITEM FOR CONTINUATION**

Staff requested the continuation of Agenda Item #4 to the March 4, 2021, Design Review Board (DRB) meeting. The following items were heard for the purposes of continuation and the Public Hearing was not opened.

On a **MOTION** made by Garner and **SECONDED** by Jett, the DRB voted unanimously to continue DRB Agenda Item #4 to the March 4, 2021 Regular DRB meeting

**Item 5. Consideration of a Design Review: Final Architecture Review for a new single-family residence on Lot 518R, 146 Russell Drive, pursuant to CDC Section 17.4.11**

Amy Ward presented on behalf of staff

Steven Kahle, architect, and Kata Petty, owner, presented as the applicant

Public comment: none

On a **MOTION** by Garner and **SECONDED** by Jett the DRB voted unanimously to e to approve the Final Architectural Review for a new single-family home located at Lot 518R, based on the evidence provided within the Staff Report of record dated December 23, 2020, with the following Design Variations and Specific Approvals:

- 1) *Metal Fascia;*
- 2) *Landscaping and temporary irrigation and address monument in the GE*

And, with the following conditions:

- 1) *Prior to the issuance of a building permit, the applicant shall field verify all utilities and submit a revised utility plan to the public works director identifying the location of utilities and connection points.*
- 2) *Consistent with town building codes, Unenclosed accessory structures attached to buildings with habitable spaces and projections, such as decks, shall be constructed as either non-combustible, heavy timber or exterior grade ignition resistant materials such as those listed as WUIC (Wildland Urban Interface Code) approved products.*
- 3) *Prior to issuance of a CO, the property owner will enter into a General Easement Encroachment Agreement, as applicable, with the Town of Mountain Village for the general easement encroachments approved.*
- 4) *A monumented land survey shall be prepared by a Colorado public land surveyor to establish the maximum building height and the maximum average building height.*
- 5) *A monumented land survey of the footers will be provided prior to pouring concrete to determine there are no additional encroachments into the GE.*
- 6) *Prior to the Building Division conducting the required framing inspection, a four-foot (4') by eight-foot (8') materials board will be erected on site consistent with the review authority approval to show:*
  - a. *The stone, setting pattern and any grouting with the minimum size of four feet (4') by four feet (4');*
  - b. *Wood that is stained in the approved color(s);*
  - c. *Any approved metal exterior material;*
  - d. *Roofing material(s); and*
  - e. *Any other approved exterior materials*

**Item 6. Consideration of a Design Review: : Final Architecture Review for a new Single-Family residence on Lot 725, 131 Adams Ranch Road, pursuant to CDC section 17.4.11**

John Miller presented on behalf of staff

Edwin Lindell, architect, presented as the applicant

Public comment: none

On a **MOTION** by Garner and **SECONDED** by Craige, the DRB voted to approve 2 opposed (Kramer and Jett) the Initial Architectural and Site Review for a new single-family home located at Lot 725, based on the evidence provided within the Staff Report of record dated December 22, 2020, with the following Design Variations and Specific Approvals:

1) *Metal Fascia;*

*And, with the following conditions:*

1) *Prior to the submittal for a Building Permit, the applicant shall revise the lighting plan to provide additional details on the lighting of the address monument. In addition applicant will change fixture A to the LED version of the same, "Hevi Lite HL-340-LED."*

2) *Prior to the issuance of a building permit, the applicant shall field verify all utilities and submit a revised utility plan to the public works director identifying the location of utilities and connection points.*

3) *Consistent with town building codes, Unenclosed accessory structures attached to buildings with habitable spaces and projections, such as decks, shall be constructed as either non-combustible, heavy timber or exterior grade ignition resistant materials such as those listed as WUIC (Wildland Urban Interface Code) approved products.*

4) *Prior to issuance of a CO, the property owner will enter into a Road Right of Way and General Easement Encroachment Agreement, as applicable, with the Town of Mountain Village for the road right of way and general easement encroachments approved.*

5) *A monumented land survey of the footers will be provided prior to pouring concrete to determine there are no additional encroachments into the GE.*

6) *Prior to the Building Division conducting the required framing inspection, a fourfoot (4') by eight-foot (8') materials board will be erected on site consistent with the review authority approval to show:*

*a. The stone, setting pattern, and any grouting with the minimum size of four feet (4') by four feet (4');*

*b. Wood that is stained in the approved color(s);*

*c. Any approved metal exterior material;*

*d. Roofing material(s); and*

*e. Any other approved exterior materials*

7) *Applicant will revise the landscape plan to show aspen trees with a larger diameter.*

**Item 7. Consideration of a Design Review: Initial Architecture and Site Review for a new Single-Family residence on Lot BC513E, 104 Lawson Overlook, pursuant to CDC section 17.4.11**

John Miller presented on behalf of staff

Jack Wesson, architect, presented as the applicants

**Proposed Motion for Continuation:**

On a motion by Craige and seconded by Garner, the DRB voted unanimously to continue the Initial Architectural and Site Review for a new single-family home located at Lot BC513E to February 4, 2021 based on the evidence provided within the Staff Memo of record dated December 22, 2020

A work session with the applicant followed.

**Item 8. Comprehensive Plan Schedule and Update**

Michelle Haynes presented on behalf of staff.

**ADJOURN**

**MOTION** to adjourn by Garner seconded by Bennet, by unanimous consent, the Design Review Board voted to adjourn the January 7, 2021 meeting at 12:29 pm.

Prepared and Submitted by,

Amy Ward  
Planner

**DESIGN REVIEW BOARD MINUTES  
TOWN OF MOUNTAIN VILLAGE  
DESIGN REVIEW BOARD MEETING  
THURSDAY DECEMBER 17, 2020**

**Call to Order**

Chairman Banks Brown called the meeting of the Design Review Board (DRB) of the Town of Mountain Village to order at 11:30 AM on DECEMBER 17, 2020, held remotely via ZOOM:  
<https://us02web.zoom.us/j/82367323747?pwd=dzVrOE8zYVNIQ2tkWXF5aisxNG0wQT09>

**Attendance**

**The following Board members were present and acting:**

Banks Brown  
Greer Garner  
Cath Jett  
Liz Caton  
Adam Miller  
David Eckman  
Ellen Kramer (1<sup>nd</sup> alternate)  
Scott Bennett (2<sup>nd</sup> alternate)

**The following Board members were absent:**

David Craigie

**Town Staff in attendance:**

Michelle Haynes, Planning & Development Services Director  
John Miller, Senior Planner  
Amy Ward, Planner

**Public in attendance:**

Bruce MacIntire  
Sara D'Agostino

**Item 2. Discussion regarding a Conceptual work session for Lot 165-6, 160 Cortina Drive, to develop a new SingleFamily Common Interest residence, pursuant to CDC sections 17.4.6, 17.4.11, and 17.4.16.**

John Miller presented on behalf of staff  
Jamie Daugaard, presented as the applicant

The architect presented initial concepts and was given specific feedback from DRB.

**ADJOURN**

**MOTION** to adjourn by by unanimous consent, the Design Review Board voted to adjourn the December 17, 2020 meeting at 1:06 pm.

Prepared and Submitted by,

Amy Ward  
Planner



AGENDA ITEM 3  
PLANNING & DEVELOPMENT SERVICE  
PLANNING DIVISION  
455 Mountain Village Blvd.  
Mountain Village, CO 81435  
(970) 728-1392

**TO:** Mountain Village Design Review Board  
**FROM:** John Miller, Senior Planner  
**FOR:** Design Review Board Public Hearing; February 4, 2021  
**DATE:** January 22, 2021 (continued from January 7, 2021)  
**RE:** Staff Memo – Initial Architecture and Site Review (IASR) Lot BC513E

## APPLICATION OVERVIEW:

### PROJECT GEOGRAPHY

**Legal Description:** LOT BC513AR TOWN OF MOUNTAIN VILLAGE ACC TO A REPLAT OF LOTS BC110 BC513A 615 1C 615 2CR 615 3AR TRACT 21AR TRACT OSP 21 TRACTS OS 615A B AND C AND OLD HIGHWAY RD LOCATED WITHIN N1 2S1 2 OF SEC 33 T43N R9W NMPM SAN MIGUEL COUNTY CO

**Address:** 104 Lawson Overlook  
**Applicant/Agent:** Adam Birck, Jack Wesson Architects, Inc.  
**Owner:** Lorrie Denesik  
**Zoning:** Single-Family  
**Existing Use:** Vacant Lot  
**Proposed Use:** Single-Family  
**Lot Size:** 0.597 Acres

#### **Adjacent Land Uses:**

- **North:** Open Space
- **South:** Single-Family
- **East:** Multi-Family
- **West:** Single-Family

### ATTACHMENTS

Exhibit A: Architectural Plan Set  
Exhibit B: Staff Comments



*Figure 1: Vicinity Map*

**Case Summary:** Adam Birck of Jack Wesson Architects, Inc. is requesting Design Review Board (DRB) approval of an Initial Architectural and Site Review (IASR) Application for a new single-family home on Lot BC513E, 104 Lawson Overlook. The Lot is approximately 0.597 acres and is zoned Single-Family with the approximate gross heated square footage of being 3,876 sq. ft. with an additional 565 sq. ft. of unheated garage. The applicant has



provided all the required materials for the IASR for the proposed home. This application was continued from the January hearing in order to address additional ridgeline design standards.

**Applicable CDC Requirement Analysis:** The applicable requirements cited may not be exhaustive or all-inclusive. The applicant is required to follow all requirements even if an applicable section of the CDC is not cited. ***Please note that Staff comments will be indicated by Italicized Text.***

*Table 1*

<b><u>CDC Provision</u></b>	<b><u>Requirement</u></b>	<b><u>Proposed</u></b>
<b>Maximum Building Height</b>	35' (shed) / 40' (gable) Maximum	35' – 0"
<b>Maximum Avg. Building Height</b>	30' (shed) / 35' (gable) Maximum	27' – 0 ½"
<b>Maximum Lot Coverage</b>	40% Maximum	11.4%
<b>General Easement Setbacks</b>	16 Foot General Easement	Does not comply – see notes
<b>Roof Pitch</b>		
Primary		12:12
Secondary		Multiple
<b>Exterior Material**</b>		
Stone	35% minimum	38.97%
Windows/Doors	40% maximum	14.53%
<b>Parking</b>	2 enclosed / 2 exterior	2/2

***Design Review Board Design Variations:***

- 1. Section 17.5.8 Parking Regulations***

***Design Review Board Specific Approvals:***

- 1. Parking in the General Easement***
- 2. Road and Driveway Standards***

**Chapter 17.3: ZONING AND LAND USE REGULATIONS**

**17.3.12: Building Height Limits**

Sections 17.3.11 and 17.3.12 of the CDC provide the methods for measuring Building Height and Average Building Height, along with providing the height allowances for specific types of buildings based on their architectural form. The proposed design incorporates both Gabled and Shed roof forms which are granted different height allowances in the CDC. Gabled roof forms are granted a maximum building height of 40 feet with shed roof forms limited to 35 feet. The maximum average height must be at or below 30 feet for shed roof forms and 35 feet for gable roof forms. The average height is an average of measurements from a point halfway between the roof ridge and eave. The points are generally every 20 feet around the roof. The maximum height is measured from the highest point on a roof directly down to the existing grade or finished grade, whichever is more restrictive.

*Staff: As part of this application, the applicant has provided both a Maximum Building Height and Average Building Height calculation on pages A300 – A302 and shown above in Table 1. Since the January hearing, the applicant has revised the plans to demonstrate the most restrictive grade in their parallel slope analysis and it appears that a very small portion of the roof is within the 35-foot plane on the east elevation of the home. It should be noted that this home – given the primary gabled roof forms is allowed a 40-foot maximum building height, and the proposed design is well within that allowance. Staff*

*recommends modifying this height analysis' and particularly the parallel plane in order to demonstrate the heights complying at a 40-foot limit.*

#### **17.3.14: General Easement Setbacks**

Lot BC513E is burdened by a sixteen (16) foot General Easement (GE) which surrounds its perimeter. In addition to the GE, there is a 20-foot Trail and Utility Easement along the northern portion of the lot containing an existing foot and bike trail.

The CDC provides that the GE and other setbacks be maintained in a natural, undisturbed state to provide buffering to surrounding land uses. The CDC does provide for some development activity within the GE and setbacks such as Ski Access, Utilities, Address Monuments, and Fire Mitigation. All encroachments not listed above will require encroachment agreements between the property owner and the Town.

*Staff: The proposal includes several GE encroachments that fall into the above category of permitted GE development activity including the following:*

- *Driveway and Address Monument: The driveway is designed to cross a portion of the southern GE. Additional retaining walls associated with the driveway and parking area are also located within the GE. Because of the slope required for the driveway, this area will require a large amount of fill. At the January hearing, the DRB generally provided feedback that these GE encroachments for the retaining walls associated with the driveway were preferable to pushing the home further down the lot to the north given the site complexities.*

*The address monument has also been shown in the southern GE. Based on the location of the sign, it appears that it would be readily visible from Town ROW and will provide an adequate area for snow plowing and storage.*

- *Utilities: Utilities will be required to cross all GEs except for the eastern GE due to existing locations of Sewer, Water, and Shallow Utilities.*

*The proposal also includes GE encroachments that do not fall into the above category of permitted GE development activity:*

- *Parking: The proposed exterior parking as currently shown is located within the southern General Easement.*
- *Walkway: The home is accessed from the driveway along a walkway to the front door. Nearly all of this walkway is within the southern GE.*
- *Overhanging roof eave: A portion of the roof overhang is located in the southern GE.*

*Staff: The DRB will need to determine if the parking and associated structural elements such as the walkway, roof eave, and retaining walls are appropriate. If they determine it is not appropriate, the applicant shall revise the plan accordingly. The CDC permits the DRB to waive the general easement setbacks for prohibited activities if it determines that there is a hardship such as steep slopes and there are no unreasonable negative impacts to surrounding properties. Additionally, it should be noted that by keeping the driveway and walkway within the southern GE, there may be potential to preserve more landscaping to the north of the home which would help to screen the home from the valley floor.*

## **Chapter 17.5: DESIGN REGULATIONS**

### **17.5.4: Town Design Theme**

The Town of Mountain Village has established design themes aimed at creating a strong image and sense of place for the community. Due to the fragile high alpine environment, architecture and landscaping shall be respectful and responsive to the tradition of alpine design – reflecting elements of alpine regions while blending influences that visually tie the town to mountain buildings. The town recognizes that architecture will continue to evolve and create a regionally unique mountain vernacular, but these evolutions must continue to embrace nature and traditional style in a way that respects the design context of the neighborhoods surrounding the site.

*Staff: The home can be categorized as a mountain modern design featuring a primary gabled roof with secondary shed roofs projecting off the primary roof form with perpendicular gables appearing to break up the roof lines. The design of this home is very traditional in nature and overall, it does a good job of incorporating the Mountain Village vernacular and strong design theme – expressed through the strong material palette of vertical barn wood, metal, and stone. The home is sized at approximately 4,500 gross square feet, and the mass of the home varies largely from each elevation perspective. For example, as seen from Lawson Overlook the home appears as a 2-story structure. As the perspective is shifted to the downhill sides of the home, the mass appears much large given the steepness of the site. While the home does incorporate large areas of stone on the façade, this element may increase the visual massing of the downhill areas of a home in a way that the DRB may want to minimize or otherwise break up.*

*It appears based on the applicant's submittal that the material palette for the project blends well with both the surrounding community, as well as the overall modern mountain vernacular. The material sample photos provided as part of the application demonstrate this contrast between the light tan stone, oil rubbed panels, and vertical barn wood. The materials are discussed below in more detail as it relates to the ridgeline lot requirements of Section 17.5.16.*

*It should be noted that the home's façade has been modified slightly from the last hearing in January, to incorporate a darker toned wood as well as reducing the overall fenestration on the north of the home.*

### **17.5.5: Building Siting Design**

The CDC requires that any proposed development blend into the existing landforms and vegetation.

*Staff: The topography of the site along with existing constraints presented by the utility and trail easement have driven the siting of this home. Due to these items, it appears that the siting is logical, and any further push north would create additional site disturbances that may endanger the existing trail or otherwise not be necessary. Additionally, the siting of the home allows the applicant to maintain the existing vegetation of the Lot in a way to limit its visual prominence on the ridge. Because of these reasons, staff does not recommend relocating the home and rather would suggest granting of the encroachments into the GE as described above.*

### **17.5.6: Building Design**

*Staff: The CDC requires that building form and exterior wall forms portray a mass that is thick and strong with a heavy grounded foundation. In order to accomplish this, the applicant is proposing a stone veneer surrounding the home consisting of a random arrangement of what appears to be Telluride gold stone. As discussed above, certain*

*elevations contain large amounts of stone veneer that present a large structural vertical massing, but it does appear to be broken up through the use of fenestration and undulating stone heights. Staff does not object to this design but suggests the DRB discuss if these areas provide enough variation in materials and massing to meet the Ridgeline Requirements discussed below.*

*The home's exterior palette appears to contrast and blend well. The CDC allows for rusted metal standing seam roofing materials and this appears to meet that requirement. The garage door is plated with oil rubbed metal panels similar to other areas of the home. Since the January meeting, the color of the wood has been darkened in order to better blend with the hillside and vegetation.*

*The applicant has proposed 1000 square feet of snowmelt which is shown on page A105. As a note, any amount of snowmelt over 1000 square feet requires energy offsets.*

#### **17.5.7: Grading and Drainage Design**

*Staff: The applicant has provided a conceptual grading and drainage plan as it relates to access for the driveway and to areas surrounding the home that may require grading. It appears that the grading plan meets the requirements of the CDC and overall, the home has positive drainage as required. As noted above, grading has been proposed within the GE associated with the driveway. Prior to the final review, a finished slope calculation shall be provided for all areas of grading to determine appropriate revegetation and stormwater requirements. Prior to the final review, the engineer or applicant shall revise page C2.1 to demonstrate the width of the driveway and shoulders comply with the CDC.*

*There are also some discrepancies between page A100 of the plan and the grading and drainage design, specifically as it relates to the retaining walls throughout the site. Staff recommends revising the plans to demonstrate accurately both the locations and heights of these retaining walls prior to submittal for final review.*

#### **17.5.8: Parking Regulations**

*Staff: The CDC requires all single-family developments to provide two interior and two exterior parking spaces. The applicant has shown a total of 2 interior spaces on Page A202 but has not provided for the exterior spaces within the plan set. Based on the Construction Mitigation Plan, it appears that there is room for 2 exterior parking spaces within the Southern GE but the DRB will need to determine if this is appropriate per the comments discussed above related to GE encroachments.*

*The CDC also requires that garages that are designed to have cars backing out shall have a minimum of twenty-five feet of backup space. Prior to final review, the applicant shall demonstrate the requirements for exterior parking and garage backout have been met. Otherwise, the DRB will need to grant specific approval for the use of the GE, and a Design Variation to the parking regulations for the back out requirement.*

#### **17.5.9: Landscaping Regulations**

*The applicant has provided a preliminary landscaping plan to include planting notes, revegetation notes, and other general requirements. It appears that the landscaping plan meets the requirements of the CDC. It will be extremely important that any home design maintain as much existing vegetation on the north and east of the home as to ensure visual impacts from the valley floor are mitigated to all extent possible. It appears that the revised plan has addressed this concern with many more trees preserved to the north of the home.*

### **17.5.11: Utilities**

*Staff: All utilities are currently located within proximity to the home. The applicant shall work with the Public Works Director before the final review to verify the specific locations of the connections for the home. The plan set shows the proposed connections and the locations of the proposed utilities based on field research.*

### **17.5.12: Lighting Regulations**

*Staff: The applicant has provided a preliminary lighting plan demonstrating the locations and types of fixtures at a very high level. The applicants have revised their lighting plan to remove the majority of the fixtures on the north side of the home, with the exception of the in-rail lighting which shall be shielded by a metal plating surrounding the porch area.*

*It should be noted the applicant has provided a photometric study of the home as required and that all fixtures proposed otherwise meet the illumination standards of the CDC. Cut sheets have been provided for two of the four proposed fixtures. The applicant shall provide a final lighting plan based on DRB comments.*

### **17.5.13: Sign Regulations**

*Staff: The applicant has provided details on the address monument at this time. Prior to the final review, the plans should be modified to demonstrate that the lighting is compliant, and all other standards of the CDC are being met. In addition, the civil plans shall be revised to demonstrate any shallow utilities such as electrical that may be needed to illuminate the sign. This design will be re-referred to the Fire Department before that review.*

### **17.5.16: Ridgeline Lots**

*The CDC identifies Lot BC513E as a ridgeline lot and as such provides additional design restrictions. These provisions intend to require the home to maintain visual subordination to the natural landscape along the ridge. In order to accomplish this, the code requires the following:*

- 1. All structures shall have varied facades to reduce the apparent mass.  
Staff: The mass of the home has been discussed in detail within this memo, especially as it relates to the north elevation. Although the height of the home presents some massing issues, the deck areas, stone and fenestration do appear to vary this mass. Additionally, the applicant has reduced the percentage of glazing on the north side of the home and added metal accents which could further provide a varied façade. The DRB should determine if the façade has been varied enough in order to meet this requirement.*
- 2. To the extent practical, foundations shall be stepped down the hillsides to minimize cut, fill and vegetation removal.  
Staff: Because of the steepness of the lot and the restrictions presented by the existing Meadows Trail, the applicant was not able to utilize the full site in a way that would allow a traditional stepped foundation. It does appear that the applicant has tried to step the massing of the home as it travels down the slope – which may be a byproduct of the height requirements of the CDC.*
- 3. Building and roofing materials and colors shall blend with the hillside.  
Staff: The applicant has revised the materials to include a darker wood siding that appears to be more in compliance with this standard. Additionally, the large amounts of glazing along the north elevation have been slightly reduced in order*

*to address previous issues related to visibility from the valley floor, especially at night.*

4. *Colors and textures shall be used that are found naturally in the hillside.  
Staff: See above comments related to the color of the proposed materials.*
5. *Reflective materials, such as mirrored glass or polished metals, shall not be used.  
Staff: If the DRB determines that the design of the home is appropriate, then any approval should condition that all glass on the home be non-reflective glass. The applicant will also need to demonstrate that the oil rubbed metal is not reflective.*
6. *To the extent practical, no exterior lights shall be installed on the east side of buildings. Any required exterior lighting shall be shielded, recessed, or reflected so that no lighting is oriented towards the east side of the building.  
Staff: As mentioned earlier in this memo, the applicant will need to remove all lighting from the eastern side of the home to the extent practical. The lighting on the north side of the home will need to be minimized per staff's earlier comments.*

## **Chapter 17.6: SUPPLEMENTARY REGULATIONS**

### **17.6.1: Environmental Regulations**

*Staff: Fire Mitigation and Forestry Management: Due to the location of the site, staff is requesting that the fire mitigation requirements be waived except for the Zone 1 area. This will allow for additional vegetative screening to be maintained to mitigate visual impacts from the valley floor.*

*Steep Slopes: The building site does contain steep slopes but the specific percentage of the site over 30% slope has not been identified. Before submittal for final review, this shall be clarified in the survey information.*

### **17.6.6: Roads and Driveway Standards**

*Staff: Although not shown on the plans explicitly, the driveway as shown meets the CDC standards with a total drive width of approximately 20 feet. The CDC requires a 12-foot driveway for this project. This information should be specifically called out on Page C2 of the plans prior to the final review. The maximum grade of the driveway appears to be approximately 9% in the transitional area which is allowed by the CDC. The driveway appears to slightly exceed the grade for garage entrances, which will require specific approval from the DRB and the Fire Marshall and Public Works Director. Due to the steepness of the driveway, the applicant is proposing snowmelt for the entirety of the drive.*

### **17.6.8: Solid Fuel Burning Device Regulations**

*Staff: The applicant has indicated that the proposed home does include fireplaces, and these are gas burning fixtures as required. The vents for these gas fireplaces are located on the rear of the home.*

## **Chapter 17.7: BUILDING REGULATIONS**

### **17.7.19: Construction Mitigation**

*Staff: The applicant has submitted a CMP as part of this application. Staff supports the proposal with the note that any areas of the General Easement to be utilized shall be returned to the pre-disturbed condition before the project's issuance of a certificate of occupancy. Currently, some parking has been shown in the Lawson Overlook ROW and it will be important for the applicant to begin conversations with the HOA and neighbors early in the process to mitigate any negative impacts. Although not verified, staff believes*

*this project will require the use of a crane and if that is, in fact, the case, then the plans should be revised prior to final to demonstrate the radius of the crane.*

**Staff Recommendation:** Staff recommends the DRB consider this request in relation to the CDC provisions listed above and particularly in Section 17.5.16: Ridgeline Lots to determine if the home is substantially complying with these provisions. If it's determined that the home does comply with these provisions, then staff recommends approval of the IASR, but if it's determined that these provisions are not being met then the item should be continued, and the applicant should revise the plans accordingly.

**Staff Note:** *It should be noted that reasons for approval or rejection should be stated in the findings of fact and motion.*

**Proposed Motion for Approval:**

If the DRB deems this application to be appropriate for approval, Staff requests said approval condition the items listed below in the suggested motion.

I move to approve the Initial Architectural and Site Review for a new single-family home located at Lot BC513E, based on the evidence provided within the Staff Memo of record dated January 22, 2021, with the following Design Variations and Specific Approvals:

1. Design Review Board Design Variations:  
Parking Regulations
2. Design Review Board Specific Approvals:  
Parking in the General Easement  
Road and Driveway Standards

And, with the following conditions:

- 1) Prior to submittal for Final Architectural Review, the applicant shall revise the site plan to specifically document the setbacks of the home to the property lines as well as any slopes over 30%.
- 2) Prior to submittal for Final Architectural Review, the applicant will revise the civil engineering plan set to driveway widths and retaining wall locations/heights to determine the full extent of encroachments into the GE.
- 3) Areas disturbed within the General Easement utilized during construction shall be returned to the pre-disturbed condition before the project's issuance of a certificate of occupancy.
- 4) Prior to submittal for the Final Architectural Review, two exterior parking spaces must be demonstrated on the site to meet the parking requirements.
- 5) Prior to the issuance of a building permit, the applicant shall field verify all utilities and submit a revised utility plan to the public works director identifying the location of utilities and connection points.
- 6) Consistent with town building codes, Unenclosed accessory structures attached to buildings with habitable spaces and projections, such as decks, shall be constructed as either non-combustible, heavy timber or exterior grade ignition resistant materials such as those listed as WUIC (Wildland Urban Interface Code) approved products.
- 7) Prior to issuance of a CO, the property owner will enter into a Road Right of Way and General Easement Encroachment Agreement, as applicable, with the Town of Mountain Village for the road right of way and general easement encroachments approved.

- 8) A monumented land survey shall be prepared by a Colorado public land surveyor to establish the maximum building height and the maximum average building height (consistent with CDC Section 17.3.12.C.)
- 9) A monumented land survey of the footers will be provided prior to pouring concrete to determine there are no additional encroachments into the GE.
- 10) Prior to the Building Division conducting the required framing inspection, a four-foot (4') by eight-foot (8') materials board will be erected on site consistent with the review authority approval to show:
  - a. The stone, setting pattern, and any grouting with the minimum size of four feet (4') by four feet (4');
  - b. Wood that is stained in the approved color(s);
  - c. Any approved metal exterior material;
  - d. Roofing material(s); and
  - e. Any other approved exterior materials

/jjm



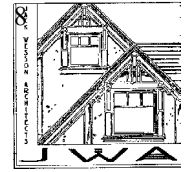

## NARRATIVE

11-30-20

To: Community Development Department  
Design Review Board  
Mountain Village, CO

From: Adam Birck  
Jack Wesson Architects, Inc.  
P.O. Box 2051  
Telluride, CO 81435  
(970) 519.1551  
jwesson@me.com.com  
adam.birck@gmail.com

Re: Design Review Submission Narrative for a Single Family Residence  
Lot BC513E, Mountain Village

This single family residence is proposed to be built on lot BC513E (lot size 26,000 sf). The interior gross heated area is approximately 3876 s.f, plus a 565 s.f. two car garage. The design aesthetic is a rustic, mining vernacular in material and massing components. The exterior materials incorporate antique barn wood siding and timbers, stone and rusted metal. Roof forms are traditional sheds forms, composed in a dynamic juxtaposition. The project is compliant with the Land Use Ordinance; the massing is within the maximum height limits. The site coverage of 2950 sf., calculated to 11.3%, does not exceed 40% max.

No variances are requested.

The exterior materials meet the surface area criteria:

stone veneer is	38.97% (exceeds 35%)
fenestration is	32.56%
wood is	16.99%
metal accent is	11.49%

Lot Area:	26000 s.f.
Site Coverage:	2975 s.f. (11.4%)
Floor Area Living:	3955 s.f. (w/ 105 s.f. of mech included)
Floor Area Garage	565 s.f.
Ave. Ht.	27'-0 1/2" (30' max.ave. allowed)
Max. Ht.	35' max. height (ridgeline lot)

Sincerely,  
Adam Birck



## DESIGN REVIEW PROCESS APPLICATION

**PLANNING & DEVELOPMENT SERVICES**  
 455 Mountain Village Blvd. Suite A  
 Mountain Village, CO 81435  
 970-728-1392  
 970-728-4342 Fax  
 cd@mtnvillage.org

DESIGN REVIEW PROCESS APPLICATION		
APPLICANT INFORMATION		
<b>Name:</b> Jack Wesson Architects inc.	<b>E-mail Address:</b> jwesson@me.com	
<b>Mailing Address:</b> POB 2051	<b>Phone:</b> 970.519.1551	
<b>City:</b> Telluride	<b>State:</b> CO	<b>Zip Code:</b> 81435
<b>Mountain Village Business License Number:</b> 001939		
PROPERTY INFORMATION		
<b>Physical Address:</b> TBD Lawson Overlook		<b>Acreage:</b> .597 acres
<b>Zone District:</b> Residential	<b>Zoning Designations:</b> Single Family Residential	<b>Density Assigned to the Lot or Site:</b> 4 people- 1 sf residence
<b>Legal Description:</b> Lot BC 513 E		
<b>Existing Land Uses:</b> Vacant		
<b>Proposed Land Uses:</b> single family		
OWNER INFORMATION		
<b>Property Owner:</b> Lorrie Denisik	<b>E-mail Address:</b> lorrie@residetelluride.com	
<b>Mailing Address:</b> POB 3352	<b>Phone:</b> 970.729.1783	
<b>City:</b> Telluride	<b>State:</b> CO	<b>Zip Code:</b> 81435
DESCRIPTION OF REQUEST		

BUILDING SUMMARY	
SITE PERMIT NUMBER:	-
BUILDING PERMIT NUMBER:	-
PROJECT ADDRESS:	LAWSON OVERLOOK
BLOCK:	-
LOT:	BC 513 E
LOT AREA:	26,000 SQ. FT.
ZONING DISTRICT:	SINGLE FAMILY
PROPOSED USE:	RESIDENTIAL
NUMBER OF STORIES:	2
NUMBER OF SUB-LEVELS:	1

CODE SUMMARY	
BUILDING CODE:	INTERNATIONAL RESIDENTIAL CODE (2012) INTERNATIONAL ELECTRICAL CODE (2012) INTERNATIONAL FIRE CODE (2012) INTERNATIONAL MECHANICAL CODE (2012) INTERNATIONAL PLUMBING CODE (2012)
ENERGY CODE:	NATIONAL ENERGY CODE (2017)
TYPE OF CONSTRUCTION:	TYPE 5-B
OCCUPANCY:	R-3
BUILDING AREA:	3,876 SF LIVING 4,546 TOTAL ***FIRE SPRINKLERS REQUIRED***
	130 LB GROUND SNOW LOAD, 90 MPH EXPOSURE C WIND, FROST DEPTH 48"

GN16- UNLESS OTHERWISE NOTED, DIMENSIONS ARE ASSUMED TO BE:

A. PLUMB  
B. LEVEL  
C. SQUARE  
E. PARALLEL  
F. TO ESTABLISHED AXES OR BASELINES AS ESTABLISHED BY DIMENSIONAL OR ANGULAR NOTATIONS

GN17- ALL GLASS MUST CONFORM TO CODE REQUIREMENTS FOR SAFETY GLAZING.

GN18- MATERIALS, WHERE REQUIRED, ARE TO HAVE AN UL LABEL IN AN INCONSPICUOUS BUT VISIBLE LOCATION.

GN19- SIZES, DIMENSIONS, LOCATIONS, AND DETAILS OF PLANTERS, TREE GATES, CONCRETE FINISH, TILE PATTERNS, GRADING, SITE LIGHTING, ETC., ASSOCIATED WITH LANDSCAPE ARE SHOWN ON LANDSCAPE DRAWINGS.

GN20- SIZES, DIMENSIONS, LOCATIONS AND DETAILS OF UTILITY LINES, AGGREGATE BASES, SPOT ELEVATIONS ETC., ASSOCIATED WITH CIVIL ARE SHOWN ON THE CIVIL DRAWINGS.

GN21- SIZES, DIMENSIONS, LOCATIONS AND DETAILS OF STRUCTURAL MEMBERS, BEAMS, SLABS, WALLS, OPENINGS, ETC., ARE SHOWN ON STRUCTURAL DRAWINGS.

GN22- SIZES, DIMENSIONS, LOCATIONS AND DETAIL OF REGISTERS, DUCTS, EQUIPMENT, WALL OPENINGS, LOUVERS, ACCESS HATCHES, EQUIPMENT CURBS, VENTS, ETC., ASSOCIATED WITH HEATING VENTILATING AND AIR CONDITIONING ARE CONTAINED ON THE MECHANICAL DRAWINGS. COORDINATE LOCATION OF REGISTERS WITH ARCHITECTURAL REFLECTED CEILING PLAN.

ABBREVIATIONS & SYMBOLS	
WALL, BUILDING OR MISCELLANEOUS SECTION NO. DRAWING NO.	
INTERIOR ELEVATION NO. SHEET NO.	
ROOM NAME ROOM NO.	
DOOR NO.	
ELEVATION WINDOW NO.	
FRAME WALL	
BRICK/STONE VENEER	
SPOT ELEVATION	
ROOF SLOPE	

**GENERAL NOTES**

GN01- CONTRACT DOCUMENTS CONSIST OF THE AGREEMENT, GENERAL CONDITIONS, SPECIFICATIONS, AND DRAWINGS WHICH ARE COOPERATIVE AND CONTINUOUS. WORK INDICATED OR REASONABLY IMPLIED IN ANY ONE OF THE CONSTRUCTION DOCUMENTS SHALL BE SUPPLIED AS THOUGH FULLY COVERED IN ALL. ANY DISCREPANCIES BETWEEN THE PARTS SHALL BE REPORTED TO ARCHITECT PRIOR TO COMMENCEMENT OF WORK.

GN02- MATERIALS AND ASSEMBLIES:  
ALL WORK SHALL COMPLY WITH APPLICABLE STATE AND LOCAL CODES, O.S.H.A. REQUIREMENTS, ORDINANCES, AND REGULATIONS. THE CONTRACTOR, SUB-CONTRACTORS AND JOURNEYMEN OF THE APPROPRIATE TRADES SHALL PERFORM WORK TO THE HIGHEST STANDARDS OF CRAFTSMANSHIP.

GN03- CONTRACTOR TO REVIEW GEO-TECHNICAL REPORT FOR BUILDING SYSTEM RECOMMENDATIONS. SHOULD UNEXPECTED SITE CONDITIONS ARISE DURING EXCAVATION, THE ARCHITECT AND GEO-TECHNICAL ENGINEER SHALL BE NOTIFIED FOR A SITE EVALUATION OF EXISTING CONDITIONS.

GN04- THE CONTRACTOR SHALL CAREFULLY STUDY AND COMPARE THE DOCUMENTS, VERIFY THE ACTUAL CONDITIONS AND REPORT ANY DISCREPANCIES, ERRORS OR OMISSIONS TO THE ARCHITECT IN A TIMELY MANNER. THE ARCHITECT SHALL CLARIFY OR PROVIDE REASONABLE ADDITIONAL INFORMATION REQUIRED FOR SUCCESSFUL EXECUTION. THE CONTRACTOR SHALL VERIFY AND COORDINATE ALL OPENINGS THROUGH THE FLOORS, CEILING AND WALLS WITH ALL ARCHITECTURAL, INTERIOR, STRUCTURAL, MECHANICAL AND PLUMBING, ELECTRICAL AND LIGHTING DRAWINGS.

GN05- ALL REQUIRED WORK SHALL BE PERFORMED BY THE CONTRACTOR UNLESS OTHERWISE NOTED. ALL REFERENCES TO THE "CONTRACTOR" INCLUDE GENERAL CONTRACTOR AND HIS/HER SUBCONTRACTORS. THEY SHALL BE ONE AND THE SAME.

GN06- THE CONTRACTOR SHALL OBTAIN ALL APPLICABLE BUILDING PERMITS, ALL NECESSARY INSPECTIONS AND THE CERTIFICATE OF OCCUPANCY.

GN07- THE CONTRACTOR SHALL COMPILE AND SUBMIT AS REQUIRED TO MANUFACTURERS AND OWNER ALL MATERIAL, FIXTURE AND APPLIANCE WARRANTIES.

GN08- THE JOBSITE SHALL BE MAINTAINED IN A CLEAN AND ORDERLY MANNER, FREE OF TRASH AND CONSTRUCTION DEBRIS. THE CONTRACTOR SHALL PROVIDE FOR RECYCLING AT THE JOB SITE.

GN09- THE CONTRACTOR IS RESPONSIBLE FOR THE PROTECTION OF ALL MATERIALS BEING DELIVERED TO THE PROJECT AND THE PROTECTION OF NEIGHBORING PROPERTIES.

GN10- THE CONTRACTOR SHALL COORDINATE WITH ALL EQUIPMENT MANUFACTURERS FOR EQUIPMENT ROUGH-IN REQUIREMENTS.

GN11- THE CONTRACTOR SHALL VERIFY REQUIRED LOCATIONS OF ALL NECESSARY ACCESS PANELS IN ALL PARTITIONS, FLOORS, CEILING, AND WALLS AND COORDINATE EXACT LOCATIONS WITH THE ARCHITECT PRIOR TO INSTALLATION. ALL ACCESS PANELS SHALL BE INSTALLED FLUSH TO SURFACE WITH NO TRIM.

GN12- FOR THIS PROJECT, DATUM 100.00' IS SET AT FINISH FLOOR, MAIN LEVEL OF THE UNIT.

GN13- DATUM ELEVATIONS ARE GIVEN TO TOP OF FINISH FLOOR. ALL OTHER FINISH MATERIALS ARE ADDED TO THESE GIVEN ELEVATIONS UNLESS OTHERWISE NOTED.

GN14- DO NOT OBTAIN DIMENSIONS BY SCALING DRAWINGS - USE WRITTEN DIMENSIONS. CONTRACTOR SHALL VERIFY ALL DIMENSIONS AND ANY DISCREPANCY SHALL BE REPORTED TO THE PROJECT ARCHITECT BEFORE THE COMMENCEMENT OF WORK.

GN15- UNLESS OTHERWISE NOTED, DIMENSIONS ARE TAKEN TO THE FOLLOWING IN ORDER OF PRIORITY:

A.B.	AS BUILT / ANCHOR BOLT	MAX.	MAXIMUM
A.C.T.	ACOUSTICAL CEILING TILE	MECH.	MECHANICAL
ADJ.	ADJUSTABLE	MFG.	MANUFACTURER
A.F.F.	ABOVE FINISH FLOOR	M.H.	MANHOLE
ALT.	ALTERNATE	MIN.	MINIMUM
ALUM.	ALUMINIUM	MISC.	MISCELLANEOUS
BD.	BOARD	M.L./ML	MICRO-LAM
BLDG.	BUILDING	M.L.R./MB	MICRO-LAM BEAM.
BOT.	BOTTOM	N.I.C.	NOT IN CONTRACT
BYND.	BEYOND	NO.	NUMBER
C.A.T.V.	CABLE TELEVISION LINE	N.T.S.	NOT TO SCALE
C.J.	CONTROL JOINT	O.C.	ON CENTER
C.M.U.	CONCRETE MASONRY UNIT	O.P.	OUTSIDE DIAMETER
COL.	COLUMN	OPNG.	OPENING
CONC.	CONCRETE	OPP.	OPPOSITE
CONT.	CONTINUOUS	PERF.	PERFORATED
CTR.	CENTER	P.L.	PROPERTY LINE
DET.	DETAIL	P.LAM.	PLASTIC LAMINATE
DIAG.	DIAGONAL ELECTRIC LINE	POL.	POLISHED
EA.	EACH	PR.	PAIR
E.J.	EXPANSION JOINT	PTD.	PAINTED
EQ.	EQUAL	REQD.	REQUIRED
EXP. JT.	EXPANSION JOINT	RM.	ROOM
EXT.	EXTERIOR	R.O.	ROUGH OPENING
FIN.FL/F.F.	FINISHED FLOOR	SCHED.	SCHEDULE
FIN. GR.	FINISH GRADE FLOOR	SHT.	SHEET
F.S.P.	FIRE STAND PIPE	SIM.	SIMILAR
F.V.	FIELD VERIFY	SPEC.	SPECIFICATION
GA.	GAUGE	SQ. FT.	SQUARE FEET
GALV.	GALVANIZED	SQ. IN.	SQUARE INCHES
GBX.	GYPSPUM BOARD TYPEX	STD.	STANDARD
GL.	GLASS	STL.	STEEL
GB.	GYPSPUM WALL BOARD	TC.	TOP OF CURB.
H.C.	HOLLOW CORE	T & G.	TONGUE & GROOVE
H.M.	HOLLOW METAL	T.O.C.	TOP OF CONCRETE
HORIZ.	HORIZONTAL	T.O.S.	TOP OF SLAB
HVAC.	HEATING VENTILATION	TYP.	TYPICAL
I.D.	INSIDE DIAMETER	T.	TELEPHONE LINE
IN.	INCH / INCHES	U.B.C.	UNIFORM BUILDING CODE
INSUL.	INSULATION	U.N.O.	UNLESS NOTED OTHERWISE
JT.	JOINT	VERT.	VERTICAL
LAM.	LAMINATED	V.I.F.	VERIFY IN FIELD
LAV.	LAVATORY	WD.	WOOD

A. GRID LINES  
B. FLOOR LINES  
C. WORK POINTS  
D. STRUCTURAL STEEL  
E. FACE OF STUD  
F. FACE OF CONCRETE  
G. FACE OF FINISH

**DRAWING INDEX**

**ARCHITECTURAL**

- A000 PROJECT DATA, DRAWING INDEX, PROJECT DIRECTORY SURVEY
- A100 SITE PLAN
- A101 CONSTRUCTION STAGING PLAN
- A102 FIRE MITIGATION PLAN
- A103 LANDSCAPE & IRRIGATION PLAN
- A104 EXTERIOR LIGHTING PLAN
- A105 SNOW MELT PLAN
- A200 BASEMENT PLAN
- A201 ENTRY LEVEL PLAN
- A202 UPPER LEVEL PLAN
- A203 ROOF PLAN
- A210 AREA ANALYSIS
- A300 ELEVATION
- A301 ELEVATION
- A302 ELEVATIONS
- A310 MATERIAL CALCS
- A600 ROOF EAVE/FASCIA DETAILS
- A601 WINDOW DETAILS
- A602 EXTERIOR DOOR DETAILS

**CIVIL**

- C1 GRADING AND DRAINAGE PLAN WITH DRIVEWAY PROFILE
- C2 UTILITY PLAN

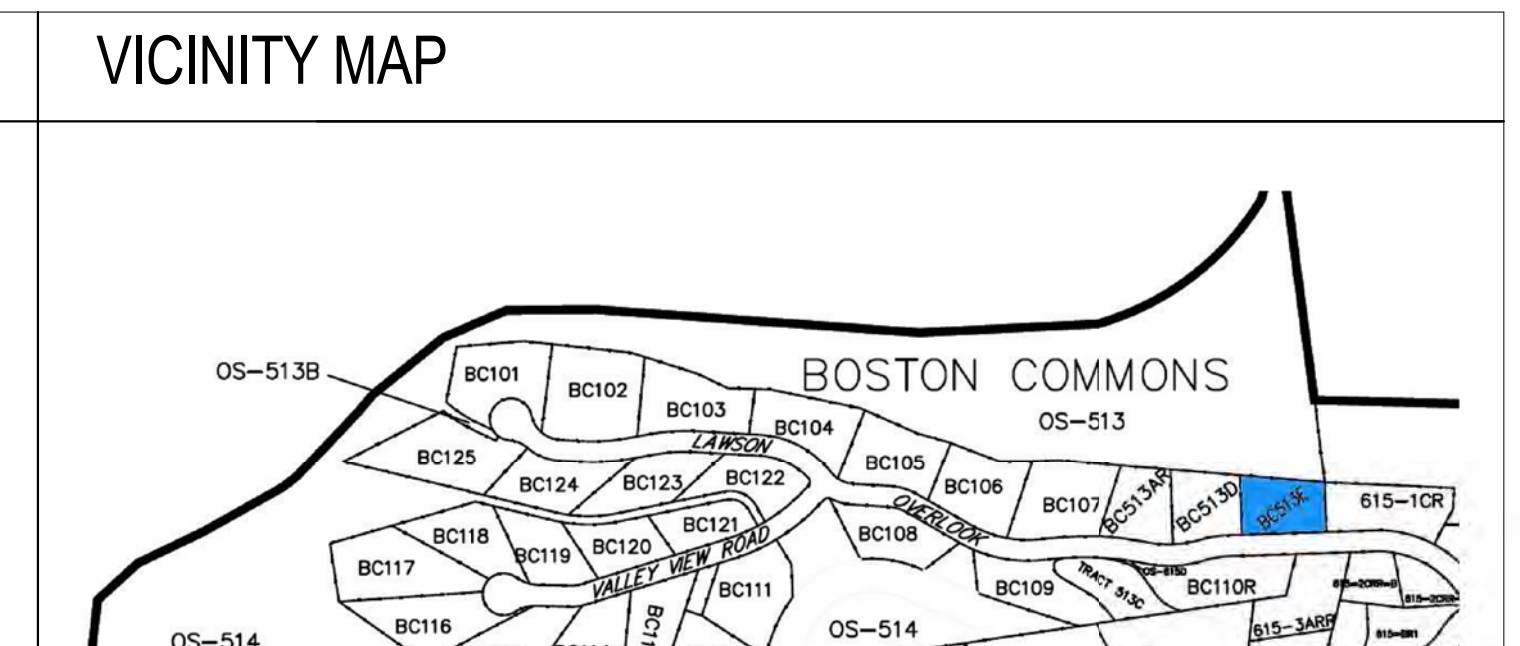

**PROJECT AXONOMETRIC**

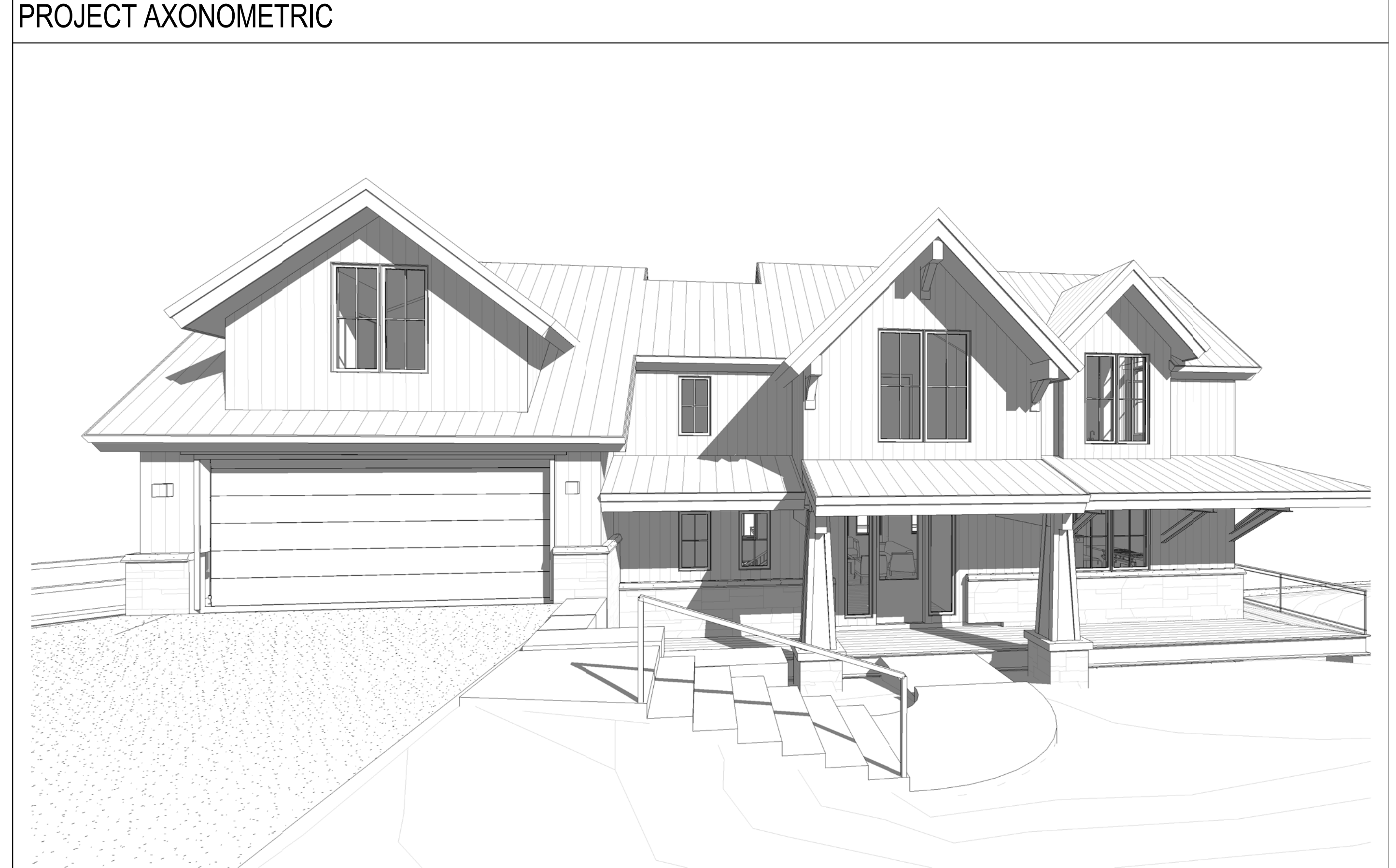

**PROJECT DIRECTORY**

**OWNER/CONTRACTOR**  
RICKY DENESIK  
RICKY@ULTRABUILDERSLLC.COM  
970-729-1221

**ARCHITECT**  
JACK WESSON ARCHITECTS, INC.  
PO BOX 457  
TELLURIDE, CO 81435  
T 970.728.9755  
jwesson@me.com  
adam.birck@gmail.com

**STRUCTURAL ENGINEER**  
COLORADO STRUCTURAL, INC.  
MIKE ARBANEY P.E.  
T 970.349.5922  
mike@coloradostructural.com

**SURVEY INFORMATION**  
SAN JUAN SURVEYING  
CHRIS KENNEDY  
102 SOCIETY DRIVE  
TELLURIDE, CO 81435  
T 970.728-1128  
office@sanjuansurveying.com

**CIVIL ENGINEER**  
DAVID BALLODE  
UNCOMPAGRE ENGINEERING, LLC  
P.O. BOX 3945  
TELLURIDE, CO 81435  
T 970-729-0683  
dballode@msn.com

**JACK WESSON ARCHITECTS INC.**

TELLURIDE, COLORADO 81435

TEL: 970.728.9755  
FAX: 970.728.9754  
jack@wessonarch.com  
www.jackwessonarchitects.com

PROJECT NAME: LOT BC513E  
MOUNTAIN VILLAGE, COLORADO 81435

SHEET DESCRIPTION: COVER SHEET

SHEET NUMBER: A000

11-30-20 DRB PACKAGE  
11-12-20 PLAN REVISIONS  
11-7-20 35' HEIGHT LIMIT  
10-6-20 DRB PACKAGE  
10-2-20 PROGRESS SET  
9-29-20 14' SHFIT  
9-24-20 PROGRESS SET  
9-21-20 DRB DRAFT 1  
9-9-20 SD PROGRESS SET  
9-4-20 SD DESIGN SET  
8-18-20 SD DESIGN SET  
8-13-20 SD DESIGN SET  
8-11-20 SD DESIGN SET  
7-29-20 SD SITE GRADE  
6-1-20 OPTIONS  
5-28-20 DESIGN DRAWINGS

MARK REV DATE DESCRIPTION

PROJECT NAME: PROJECT MANAGER: DRAWN BY: REVIEWED BY: © 2022 JWA

PraxisRegular

**PROPERTY DESCRIPTION:**

LOT BC513E, TOWN OF MOUNTAIN VILLAGE, ACCORDING TO THE REPLAT OF LOTS BC110, BC513A, 615-1C, 615-2CR, 615-3AR, TRACTS 21-ARR, OSP-21, OS-615A, OS-615B, OS-615C AND OLD HIGHWAY ROAD, TOWN OF MOUNTAIN VILLAGE, COLORADO, ACCORDING TO THE PLAT RECORDED JUNE 07, 2000 IN PLAT BOOK 1 AT PAGE 2729.

COUNTY OF SAN MIGUEL,  
STATE OF COLORADO.

**SURVEYOR'S CERTIFICATE:**

I, Thomas A. Clark, being a Colorado Licensed Land Surveyor, do hereby certify that this Topographic Survey of Lot BC513E, Mountain Village was made by me and under my direct supervision, responsibility, and checking. This Topographic Survey does not constitute a Land Survey Plat or Improvement Survey Plat as defined by Title 38, Article 51 C.R.S.

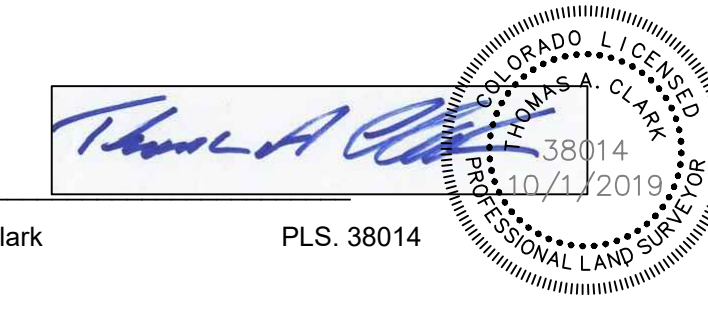

Thomas A. Clark PLS. 38014

**NOTES:**

1. Field work was performed IN September 2019.
2. Elevation datum for this survey are based on "CP 10" benchmark at the South side of of lot BC513E that elevation being 9034.75.
3. This survey is valid only if a printed or electronic copy has a seal and signature of the surveyor noted within the statement above.
4. NOTICE: According to Colorado law you must commence any legal action based upon defect in this survey within three years after you first discover such defect. In no event may any action based upon any deficit in this survey be commenced more than ten years from the date of the certification shown hereon.

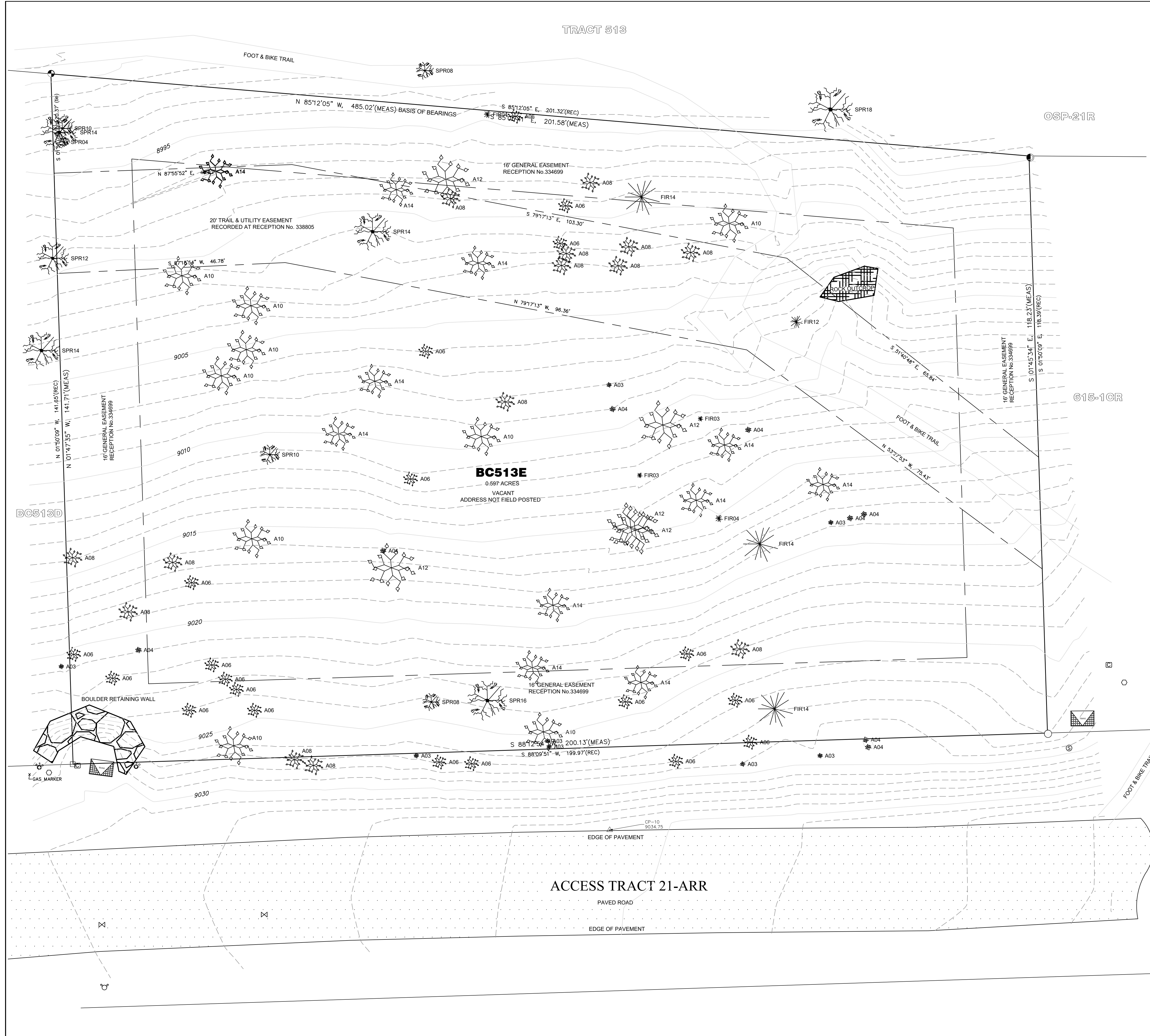

**LEGEND:**

- PAVED ROADWAY
- 
- 
- 
- 
- 
- 
- 
- 
- 

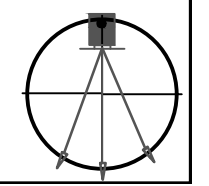
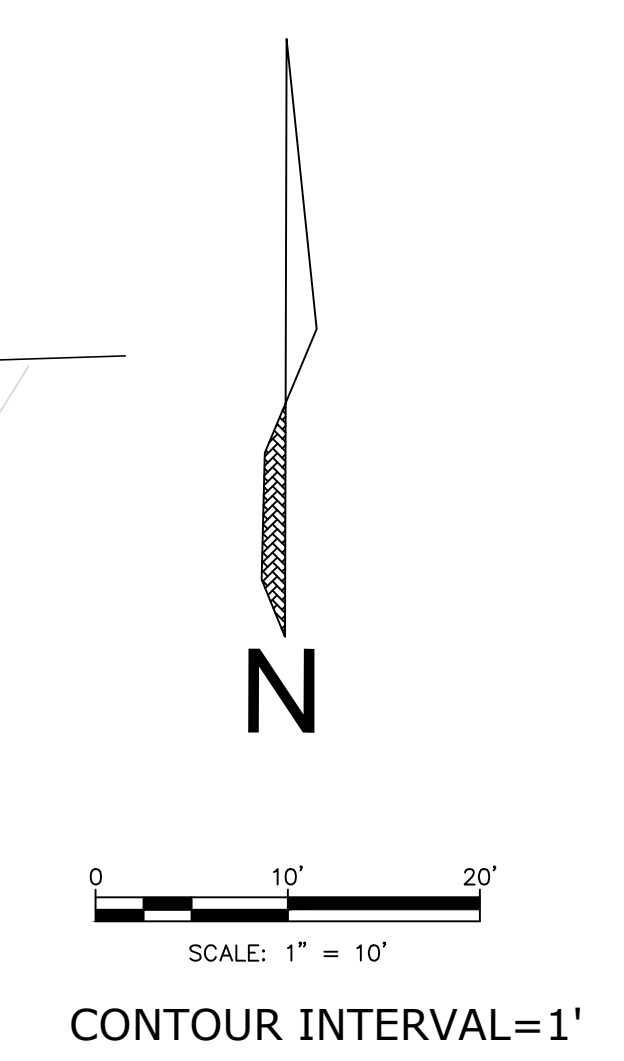

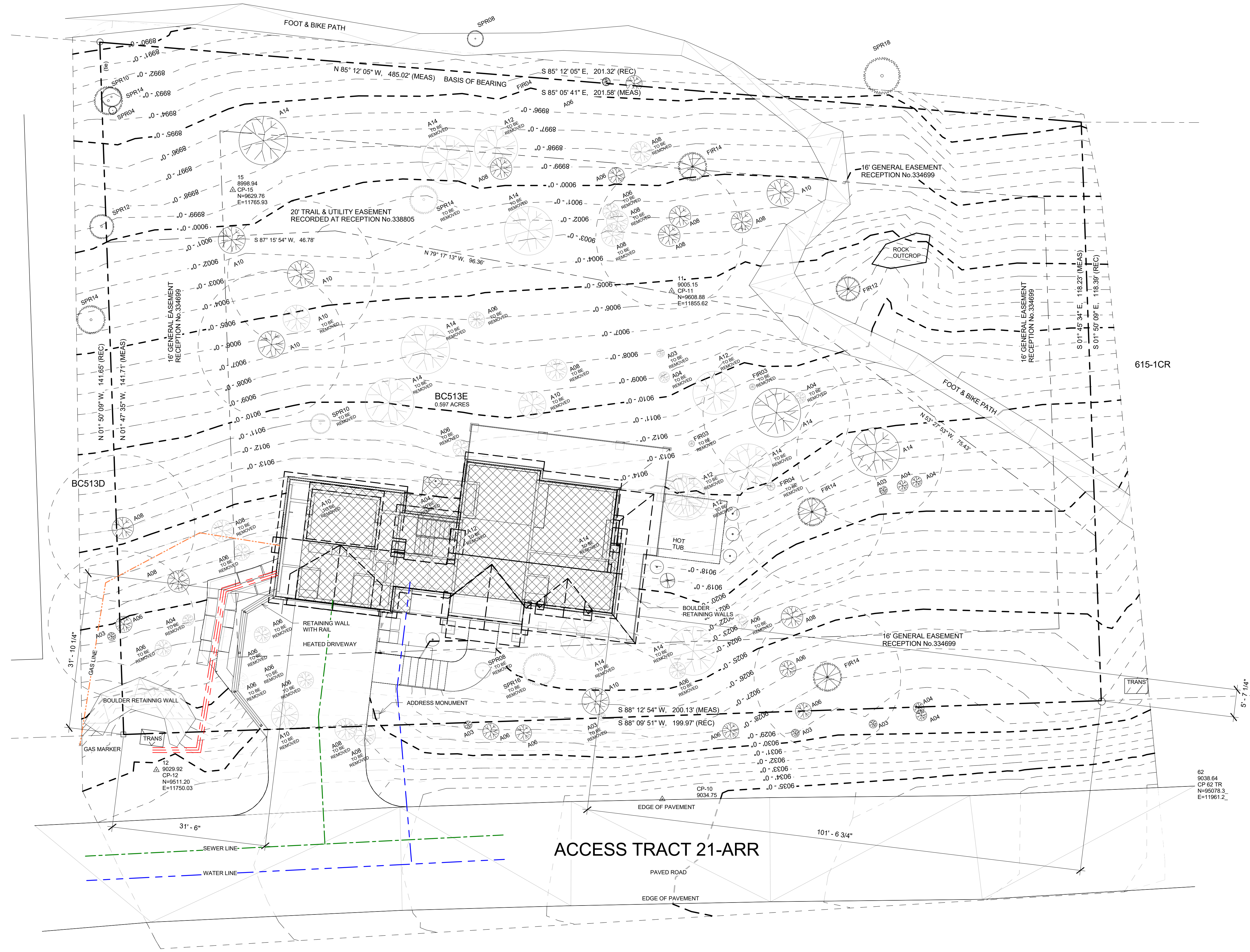

- EXISTING FIR TREE, SEE PLAN FOR SIZE
- EXISTING SPRUCE TREE, SEE PLAN FOR SIZE
- EXISTING ASPEN TREE, SEE PLAN FOR SIZE
- EXISTING FIR TREE TO BE REMOVED, SEE PLAN FOR SIZE
- EXISTING SPRUCE TREE TO BE REMOVED, SEE PLAN FOR SIZE
- EXISTING ASPEN TREE TO BE REMOVED, SEE PLAN FOR SIZE

1 A100-SITE  
3/32" = 1'-0"

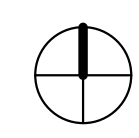
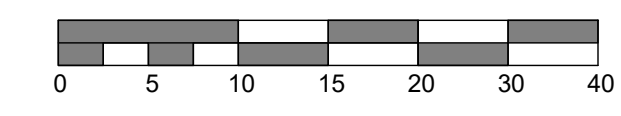

**\*\*\*SQUARE FOOTAGE REQUIRES  
A FIRE SPRINKLER SYSTEM\*\*\***

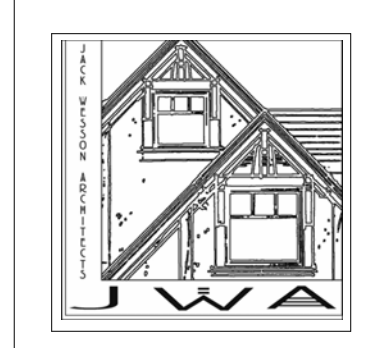

**JACK WESSON  
ARCHITECTS INC.**  
TELLURIDE, COLORADO 81435  
TEL: 970.728.9755  
FAX: 970.728.9734  
jack@wessonarch.com  
www.jackwessonarchitects.com

11-30-20	DRB PACKAGE
11-12-20	PLAN REVISIONS
11-7-20	35' HEIGHT LIMIT
10-6-20	DRB PACKAGE
10-2-20	PROGRESS SET
9-29-20	14' SHIFT
9-24-20	PROGRESS SET
9-21-20	DRB DRAFT 1
9-9-20	SD: PROGRESS SET
9-4-20	SD: DESIGN SET
8-18-20	SD: DESIGN SET
8-13-20	SD: DESIGN SET
8-11-20	SD: DESIGN SET
7-29-20	SD: SITE, GRADE
6-1-20	OPTIONS
5-28-20	DESIGN DRAWINGS

PROJECT NAME:  
**LOT BC513E**

PROJECT LOCATION:  
MOUNTAIN VILLAGE, COLORADO 81435

SHEET DESCRIPTION:  
**SITE PLAN**

SHEET NUMBER:  
**A100**

MARK	REV	DATE	DESCRIPTION

PROJECT NAME:  
PROJECT MANAGER:  
DRAWN BY:  
REVIEWED BY:  
DATE:

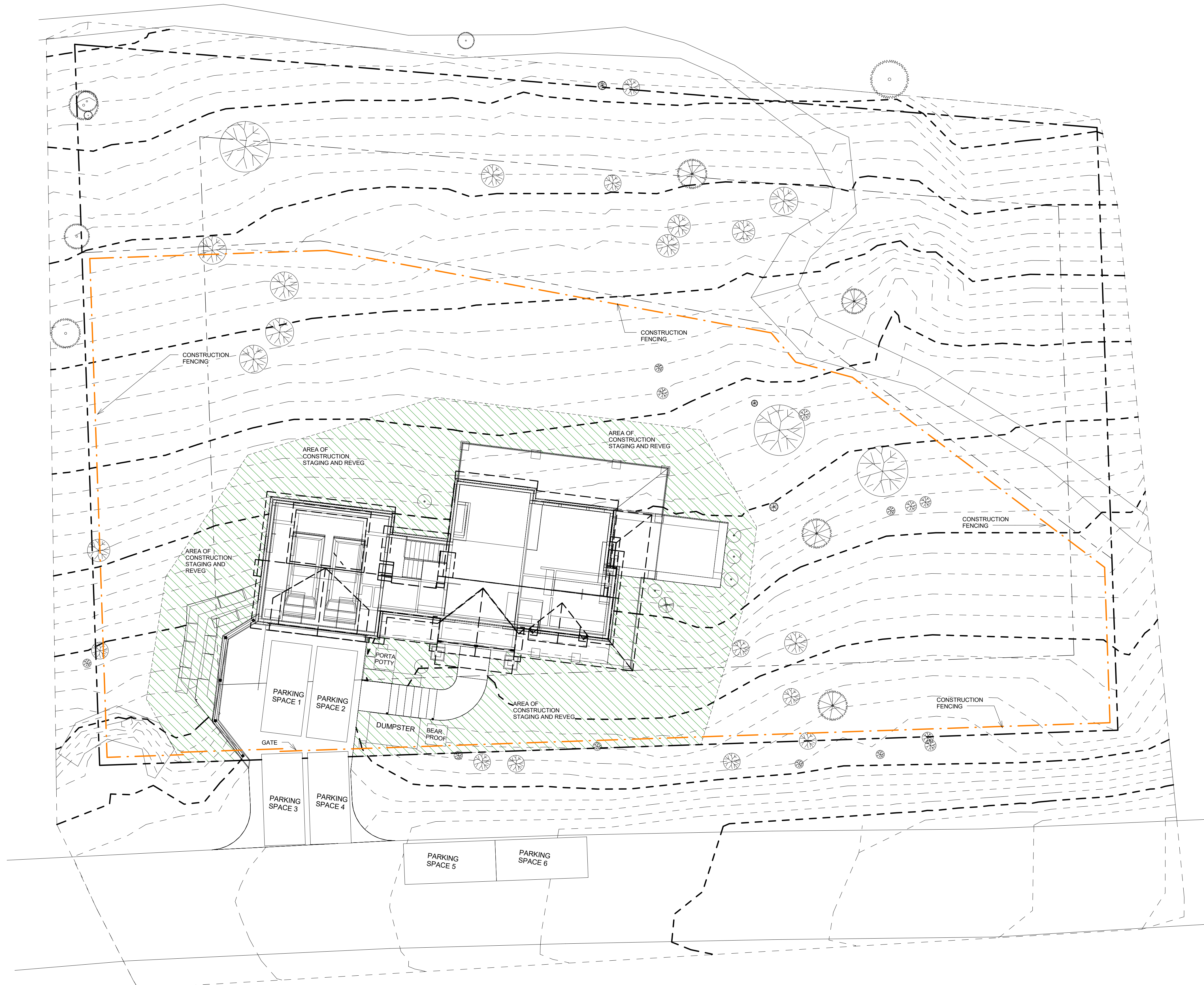

① A101-CONSTRUCTION STAGING PLAN  
3/32" = 1'-0"

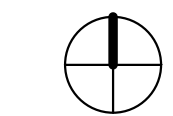
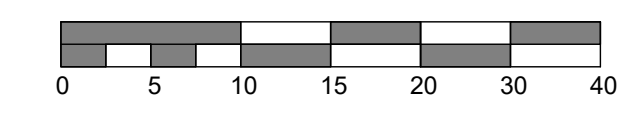

\*\*\*NOTE: ADDITIONAL TREE CLEARING WILL BE DONE IN ACCORDANCE WITH THE MOUNTAIN VILLAGE LAND USE ORDINANCE FIRE MITIGATION REQUIREMENTS\*\*\*

\*\*\*SQUARE FOOTAGE REQUIRES A FIRE SPRINKLER SYSTEM\*\*\*



**JACK WESSON  
ARCHITECTS INC.**

TELLURIDE, COLORADO 81435  
TEL: 970.728.9755  
FAX: 970.728.9724  
jack@wessonarch.com  
www.jackwessonarchitects.com

11-30-20	DRB PACKAGE	
11-12-20	PLAN REVISIONS	
11-7-20	32' HEIGHT LIMIT	
10-6-20	DRB PACKAGE	
10-2-20	PROGRESS SET	
9-29-20	14' SHIFT	
9-24-20	PROGRESS SET	
9-21-20	DRB DRAFT 1	
9-9-20	SD: PROGRESS SET	
9-4-20	SD: DESIGN SET	
8-18-20	SD: DESIGN SET	
8-13-20	SD: DESIGN SET	
8-11-20	SD: DESIGN SET	
7-29-20	SD: SITE, GRADE	
6-1-20	OPTIONS	
5-28-20	DESIGN DRAWINGS	
MARK	REV. DATE	DESCRIPTION

PROJECT NAME:  
**LOT BC513E**

MOUNTAIN VILLAGE, COLORADO 81435

SHEET DESCRIPTION:  
**CONSTRUCTION STAGING PLAN**

SHEET NUMBER:  
**A101**

PROJECT NAME:  
PROJECT MANAGER:  
DRAWN BY:  
REVIEWED BY:  
© 2022 JWA  
[www.jackwessonarchitects.com](http://www.jackwessonarchitects.com)

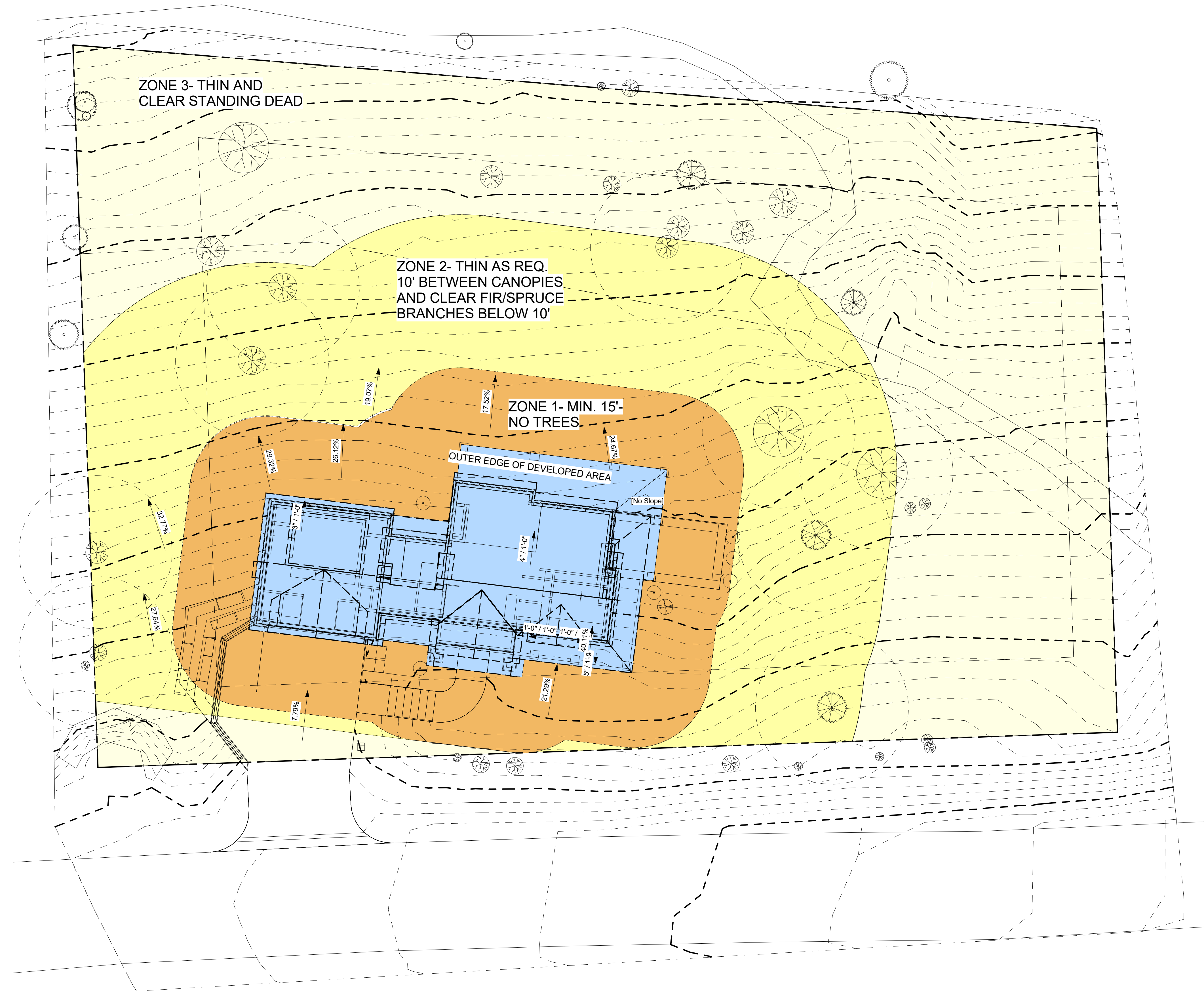

\*\*\*NOTE: ADDITIONAL TREE CLEARING WILL BE DONE IN ACCORDANCE WITH THE MOUNTAIN VILLAGE LAND USE ORDINANCE FIRE MITIGATION REQUIREMENTS\*\*\*

CONSISTENT WITH TOWN BUILDING CODES, UNENCLOSED ACCESSORY STRUCTURES ATTACHED TO BUILDINGS WITH HABITABLE SPACES AND PROJECTIONS, SUCH AS DECKS, SHALL BE CONSTRUCTED AS EITHER NON-COMBUSTIBLE, HEAVY TIMBER, OR EXTERIOR GRADE IGNITION RESISTANT MATERIALS SUCH AS THOSE LISTED AS WUIC (WILDLAND URBAN INTERFACE CODE) APPROVED PRODUCTS.

- ALL DECKS TO BE BUILT OF HEAVY TIMBER CONSTRUCTION AND FIRE RESISTANT MATERIALS
- ZONE 1- REMOVE ALL TREES
- ZONE 2- 10' SEPARATION OF CROWNS, CLEAR BRANCHES 10' FROM GROUND
- ZONE 3- THIN AND CLEAR STANDING DEAD

1 A102-FIRE MITIGATION PLAN  
3/32" = 1'-0"

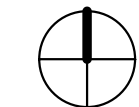
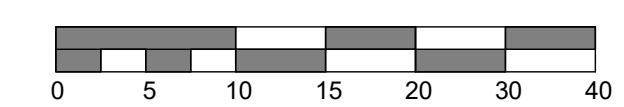

\*\*\*SQUARE FOOTAGE REQUIRES A FIRE SPRINKLER SYSTEM\*\*\*



**JACK WESSON ARCHITECTS INC.**

TELLURIDE, COLORADO 81435  
TEL: 970.728.9755  
FAX: 970.728.9754  
jack@wessonarch.com  
www.jackwessonarchitects.com

11-30-20	DRB PACKAGE	
11-12-20	PLAN REVISIONS	
11-7-20	32' HEIGHT LIMIT	
10-6-20	DRB PACKAGE	
10-2-20	PROGRESS SET	
9-29-20	14' SHIFT	
9-24-20	PROGRESS SET	
9-21-20	DRB DRAFT 1	
9-9-20	SD: PROGRESS SET	
9-4-20	SD: DESIGN SET	
8-19-20	SD: DESIGN SET	
8-13-20	SD: DESIGN SET	
8-11-20	SD: DESIGN SET	
7-29-20	SD: SITE, GRADE	
6-1-20	OPTIONS	
5-28-20	DESIGN DRAWINGS	
MARK	REV. DATE	DESCRIPTION

PROJECT NAME:  
**LOT BC513E**

MOUNTAIN VILLAGE, COLORADO 81435

SHEET DESCRIPTION:  
**FIRE MITIGATION PLAN**

SHEET NUMBER:  
**A102**

**GENERAL NOTES:**

1. SOIL PREPARATION SPECIFICATIONS: SOIL IN REVEG. AREA WILL BE AUGMENTED WITH HYDROMULCH.
2. THIS LANDSCAPE PLAN COMPLIES WITH SECTION 9-109 OF THE DESIGN REGULATIONS REGARDING NOXIOUS WEEDS.
3. THE PROPERTY OWNER GUARANTEES ALL PLANT MATERIALS FOR TWO YEAR.
4. ALL TREES AND SHRUBS SHALL BE BACKFILLED WITH A TOPSOIL/ORGANIC FERTILIZER MIXTURE AT A 2:1 RATIO.
5. PERENNIAL PLANTING BEDS SHALL BE TILLED TO A 6" DEPTH AND AMENDED WITH TOPSOIL AND ORGANIC FERTILIZER AT A 2:1 RATIO
6. MULCH ALL PERENNIAL BEDS WITH A PINE BARK SOIL CONDITIONER BY SOUTHWEST IMPORTERS; SHREDDED CEDAR BARK.
7. ALL PLANT MATERIAL TO MEET THE AMERICAN STANDARD FOR NURSERY STOCK. PLANTING DETAILS FOR ROOT SYSTEMS, SOIL PREPERATION, SEEDING, MULCHING, AND FERTILIZATION TECHNIQUES SHALL BE IN ACCORDANCE WITH GUIDELINES SET FORTH BY THE ASSOCIATED LANDSCAPE CONTRACTORS OR COLORADO.
8. TURF SHALL BE AERATED 2 TO 3 TIMES PER YEAR TO INCREASE THE WATER ABSORPTION RATES. NECESSARY ORGANIC FERTILIZATION AND AMENDMENT SHALL BE INCORPORATED AT THE SAME TIME.

**REVEGETATION AND EROSION CONTROL NOTES:**

1. SUBSOIL SURFACES SHALL BE TILLED TO A 4" DEPTH ON NON FILL AREAS.
2. TOPSOIL SHALL BE SPREAD AT A MINIMUM DEPTH OF 4" OVER ALL AREAS TO BE RE-VEGETATED (EXCEPT ON SLOPES GREATER THAN 3:1) AND AMENDMENTS ROTOTILLED AT A RATE OF 3 CUBIC YARDS PER THOUSAND SQUARE FEET.
3. BROADCASTING OF SEED SHALL BE DONE IMMEDIATELY AFTER TOPSOIL IS APPLIED (WITHIN 10 DAYS) TO MINIMIZE EROSION AND WEEDS.
4. NEWLY SEEDED AREAS SHALL BE PROTECTED FROM WIND AND WATER EROSION THROUGH THE USE OF MULCHES. ACCEPTABLE MULCHES ARE WOOD CHIPS, STRAW, HYDRO-MULCH AND EROSION-CONTROL NETTING.
5. BROADCAST WITH SPECIFIED SEED MIX AND FOLLOW WITH DRY MULCHING. STRAW OR HAY SHALL BE UNIFORMLY APPLIED OVER SEEDED AREA AT A RATE 1.5 TONS PER ACRE FOR HAY OR 2 TONS PER ACRE FOR STRAW, CRIMP IN.
7. EROSION-CONTROL NETTING WILL BE REQUIRED ON SLOPES 3:1 OR STEEPER, IF ALLOWED BY VARIANCE TO SECTION 9-103-2, AND IN DRAINAGE SWALES.
8. SEED ALL AREAS LABELED NATIVE GRASS SEED WITH THE FOLLOWING MIXTURE AT A RATE OF 12 LBS. PER ACRE.
9. ROAD AND DRIVEWAY SHALL BE RE-VEGETATED WITHIN THIRTY (30) DAYS OF THE DISTURBANCE TO AVOID UNSIGHTLY SCARS AND WEED INFESTATION ON THE LANDSCAPE. UTILITY CUTS SHALL BE RE-VEGETATED IMMEDIATELY (WITHIN TWO WEEKS) AFTER INSTALLATION OF UTILITIES TO PREVENT WEED INFESTATION. LANDOWNER SHALL INSURE PROPER WEED CONTROL IN IMPACTED AREAS.
10. EROSION CONTROL ATTENTION TO DISTURBED AREAS SHALL BE IMPLEMENTED TO ENSURE THERE IS NO DETRIMENTAL IMPACT OR RUNOFF TO ANY PONDS, STREAMS OR WETLANDS.
11. IN AREAS THAT ARE TO BE RE-VEGETATED (ESPECIALLY SEEDING LOCATIONS WHICH HAVE RECEIVED HEAVY CONSTRUCTION EQUIPMENT TRAFFIC), SOIL SHALL BE SCARIFIED BEFORE THE APPLICATION OF SEED. SLOPE SURFACES SHALL BE ROUGHENED BY RUNNING TRACKED EQUIPMENT UP AND DOWN THE FACE OF THE SLOPE. (RUNNING SUCH EQUIPMENT ACROSS THE FACE OF A SLOPE ENCOURAGES EROSION AND IS NOT RECOMMENDED).

DRAINAGE WILL MAINTAIN POSITIVE FLOW AWAY FROM THE HOUSE AS REQUIRED BY TOWN'S ADOPTIVE BUILDING CODES

THE PROJECT SHALL COMPLY WITH THE TOWNS FIRE MITIGATION STANDARDS

THE PROJECT SHALL COMPLY WITH THE ADOPTED TOWN OF MOUNTAIN VILLAGE PRESCRIPTIVE ENERGY CODE AND GREEN BUILDING STANDARDS.

**WATER USAGE CHART:**

POTENTILLA	30 @	2 gal. =	60 gal.
DOGWOOD	14 @	2 gal. =	28 gal.
TOTAL =			88 gal.

**\*NOTE: INSTALL RAIN SHUT-OFF DEVICE AS REQ'D BY SECTION 9-210**

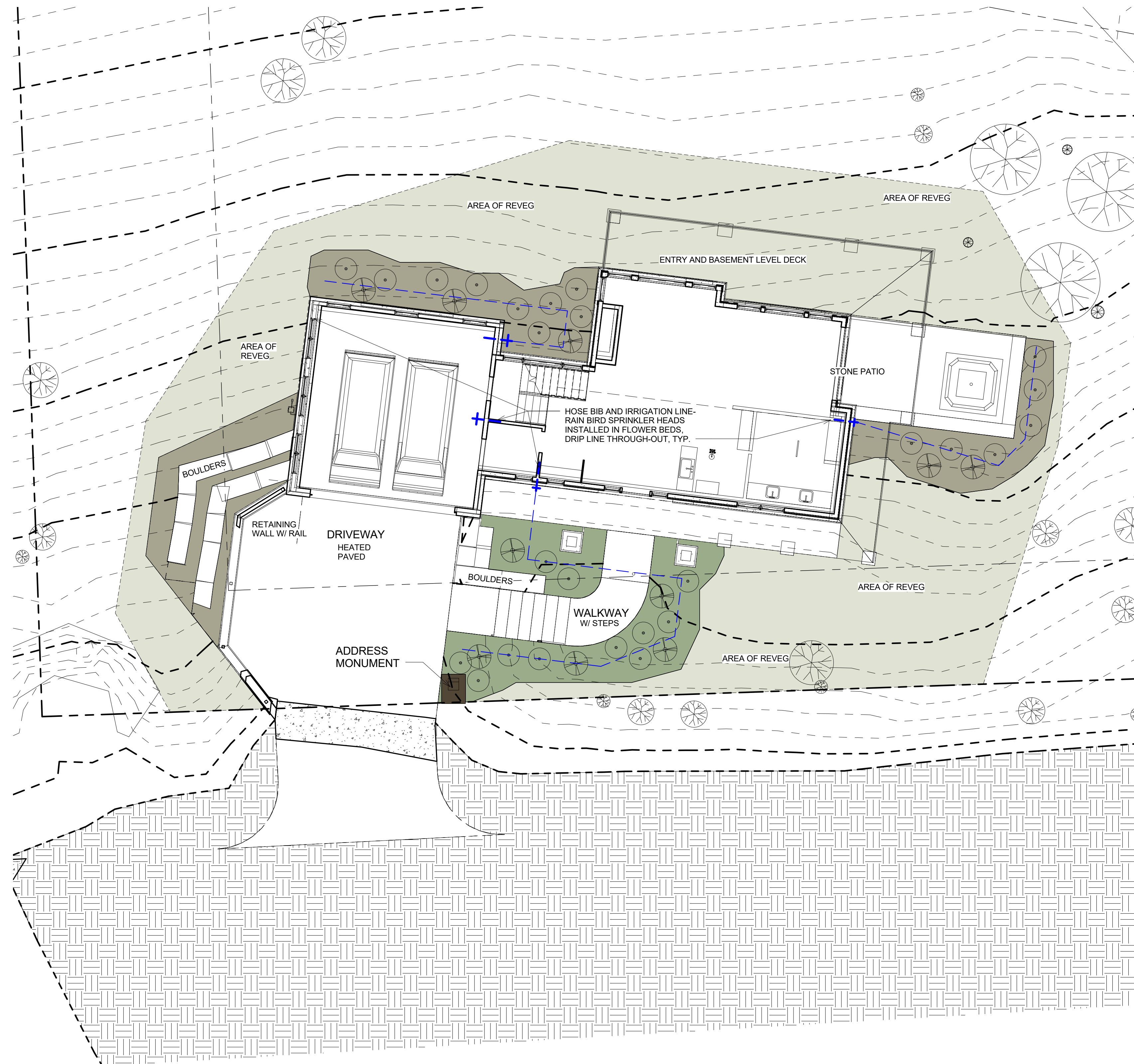

- EXISTING FIR TREE, SEE PLAN FOR SIZE
- EXISTING SPRUCE TREE, SEE PLAN FOR SIZE
- EXISTING ASPEN TREE, SEE PLAN FOR SIZE
- (11) 5 GAL. DOGWOOD SHRUBS
- (26) 5 GAL. POTENTILLA
- LANDSCAPE ZONE 1: COLUMBINE, SHOOTING STAR, INDIAN PAINTBRUSH, YARROW, BLUEBELL APPROX. 860 SF.
- LANDSCAPE ZONE 2: RUSSIAN SAGE, YELLOW ROSE, DAYLILY, DELPHINIUM, BLEEDING HEART, CINQUEFOIL APPROX 300 SF.
- NOTE: REVEGETATION IS WILL BE NATIVE MIX  
5% WESTERN YARROW  
10% TALL FESCUE  
5% ARIZONA FESCUE  
5% HARD FESCUE  
10% CREEPING RED FESCUE  
15% ALPINE BLUEGRASS  
10% CANADA BLUEGRASS  
15% PERENNIAL RYEGRASS  
10% SLENDER WHEATGRASS  
15% MOUNTAIN BROME  
APPROX. 3540 SF

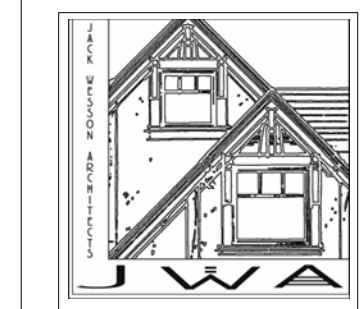

**JACK WESSON**  
ARCHITECTS INC.

TELLURIDE, COLORADO 81435  
TEL: 970.728.9755  
FAX: 970.728.9754  
jack@wessonarch.com  
www.jackwessonarchitects.com

MARK	REV	DATE	DESCRIPTION
11-30-20	DRB PACKAGE		
11-12-20	PLAN REVISIONS		
11-7-20	35' HEIGHT LIMIT		
10-6-20	DRB PACKAGE		
10-2-20	PROGRESS SET		
9-29-20	14' SHIFT		
9-24-20	PROGRESS SET		
9-21-20	DRB DRAFT 1		
9-9-20	SD: PROGRESS SET		
9-4-20	SD: DESIGN SET		
8-19-20	SD: DESIGN SET		
8-13-20	SD: DESIGN SET		
8-11-20	SD: DESIGN SET		
7-29-20	SD: SITE, GRADE		
6-1-20	OPTIONS		
5-28-20	DESIGN DRAWINGS		

PROJECT NAME:  
**LOT BC513E**

MOUNTAIN VILLAGE, COLORADO 81435

SHEET DESCRIPTION:  
**LANDSCAPE PLAN**

SHEET NUMBER:  
**A103**

1 A103-LANDSCAPE AND IRRIGATION PLAN  
1/8" = 1'-0"

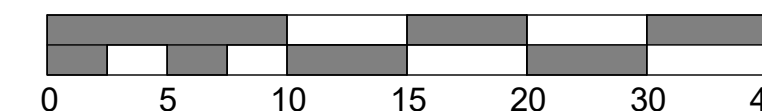

**SHOULD THE STATE OF THE GENERAL EASEMENTS BE DISTURBED DURING CONSTRUCTION, THE APPLICANT MUST REVEGETATE THE AREA TO ITS PRIOR CONDITION USING THE NATIVE SEED MIX.**

**\*\*\*SQUARE FOOTAGE REQUIRES A FIRE SPRINKLER SYSTEM\*\*\***

PROJECT NAME	
PROJECT MANAGER	
DRAWN BY	
REVIEWED BY	
DATE	



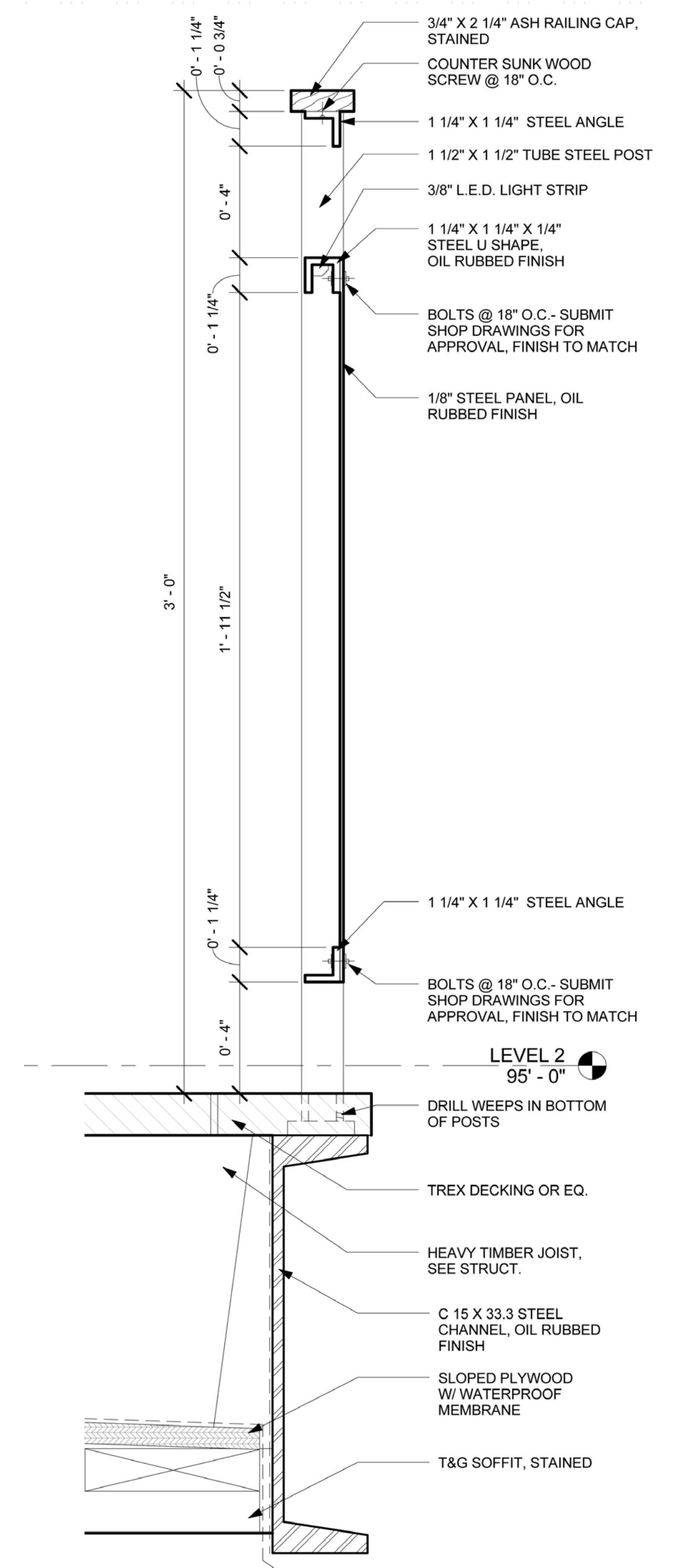

3 DETAIL- RAILING @ NORTH DECK  
3" = 1'-0"

\*\*\*ALL LIGHTING TO BE ON A DIMMER MANAGEMENT SYSTEM\*\*\*



A: EXTERIOR SCONCE: 10" Square Exterior LED Outdoor Sconce by MODERN FORMS WS-W38610  
630 lumens per fixture = 55.85 footcandles - see cut sheet



B: SMALL EXTERIOR DOWNLIGHT: aspectLED 2.25" LED Recessed Light  
210 lumen max per fixture = 19.8 footcandles- see cut sheet



C: EXTERIOR STEP LIGHT: Louver Brick by WAC  
45 lumens per fixture = 4.18 footcandles - see cut sheet



D: EXTERIOR ROPE LIGHT in railing, fully downshilded  
135 lumens per foot = 12.55 footcandles - see cut sheet

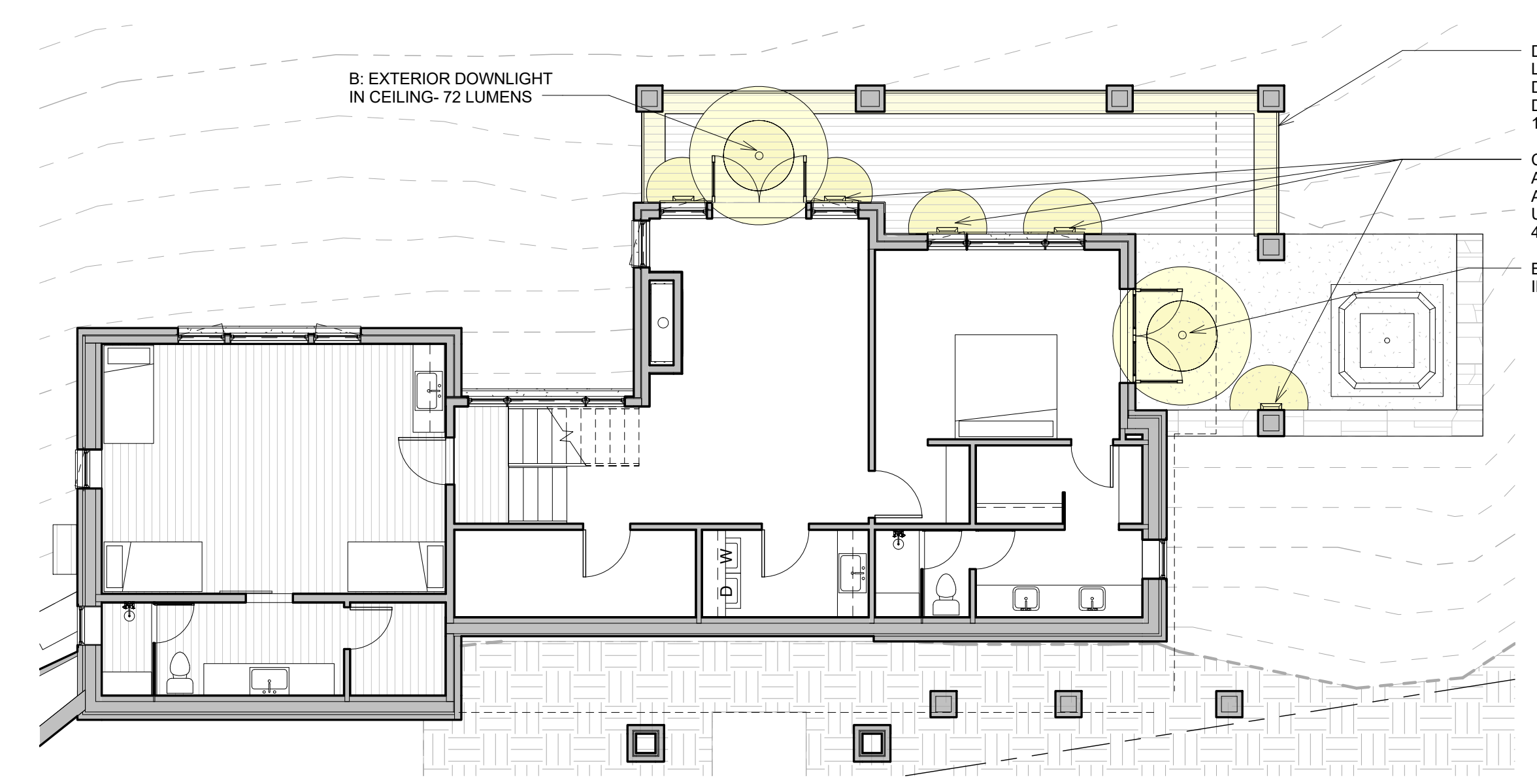

A104- BASEMENT EXTERIOR LIGHTING PLAN  
1/8" = 1'-0"

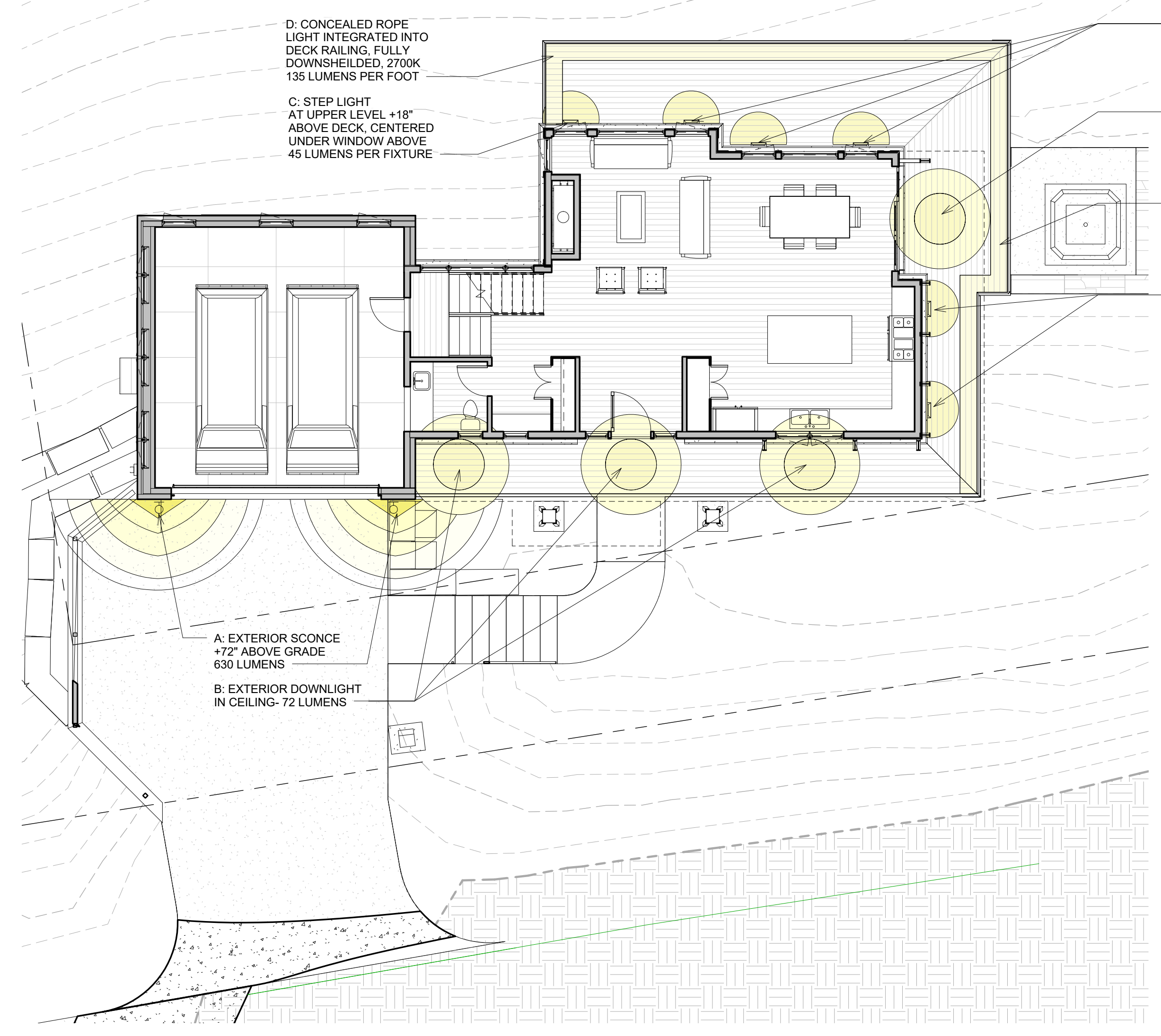
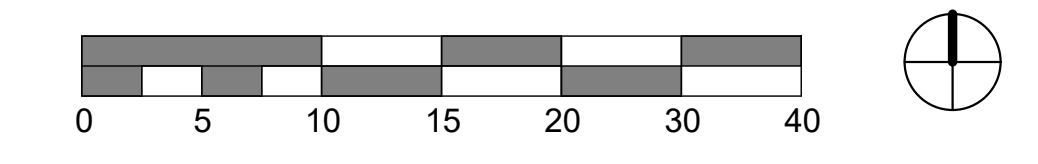

A104- ENTRY LEVEL EXTERIOR LIGHTING PLAN  
2 1/8" = 1'-0"

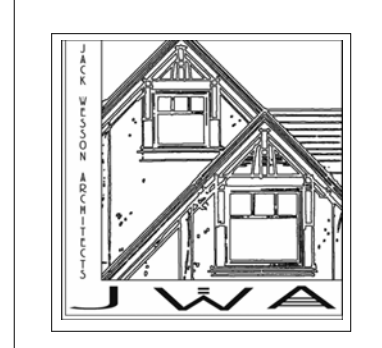
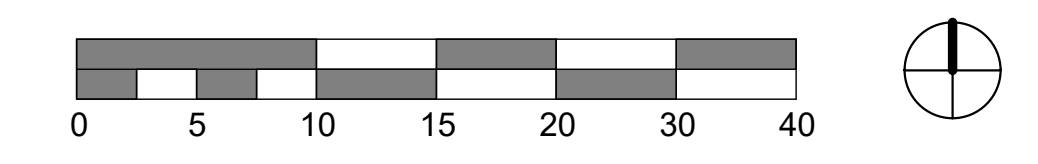

**JACK WESSON**  
**ARCHITECTS INC.**  
TELLURIDE, COLORADO 81435  
TEL: 970.728.9755  
FAX: 970.728.9734  
jack@wessonarch.com  
www.jackwessonarchitects.com

MARK	REV	DATE	DESCRIPTION
	11-30-20		DRB PACKAGE
	11-12-20		PLAN REVISIONS
	11-7-20		35' HEIGHT LIMIT
	10-6-20		DRB PACKAGE
	10-2-20		PROGRESS SET
	9-29-20		14' SHIFT
	9-24-20		PROGRESS SET
	9-21-20		DRB DRAFT 1
	9-9-20		SD- PROGRESS SET
	9-4-20		SD- DESIGN SET
	8-18-20		SD- DESIGN SET
	8-13-20		SD- DESIGN SET
	8-11-20		SD- DESIGN SET
	7-29-20		SD- SITE, GRADE
	6-1-20		OPTIONS
	5-28-20		DESIGN DRAWINGS

PROJECT NAME: **LOT BC513E**  
MOUNTAIN VILLAGE, COLORADO 81435  
SHEET DESCRIPTION: **EXTERIOR LIGHTING PLAN**  
SHEET NUMBER: **A104**

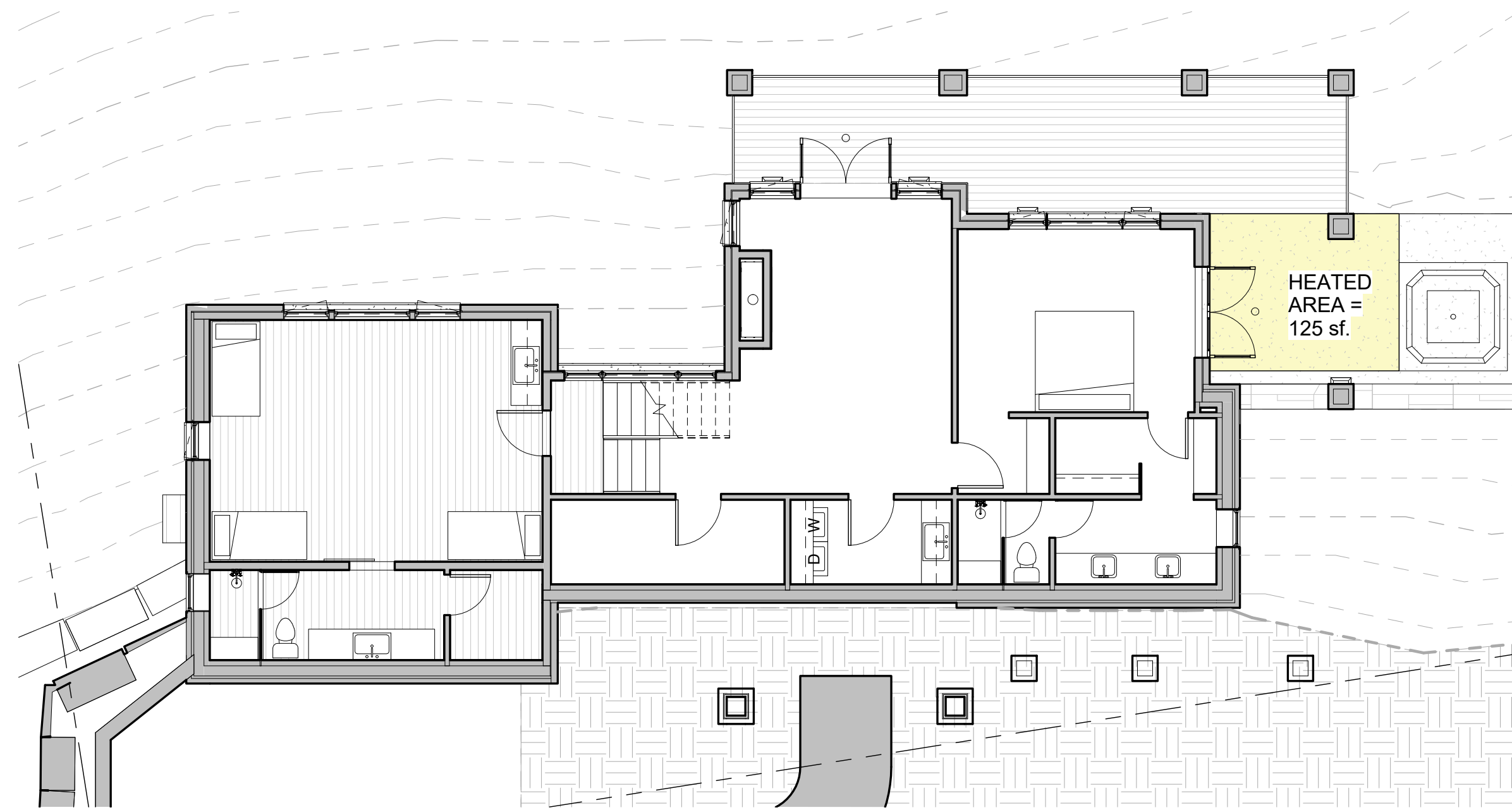

① A105- BASEMENT SNOW MELT PLAN  
1/8" = 1'-0"

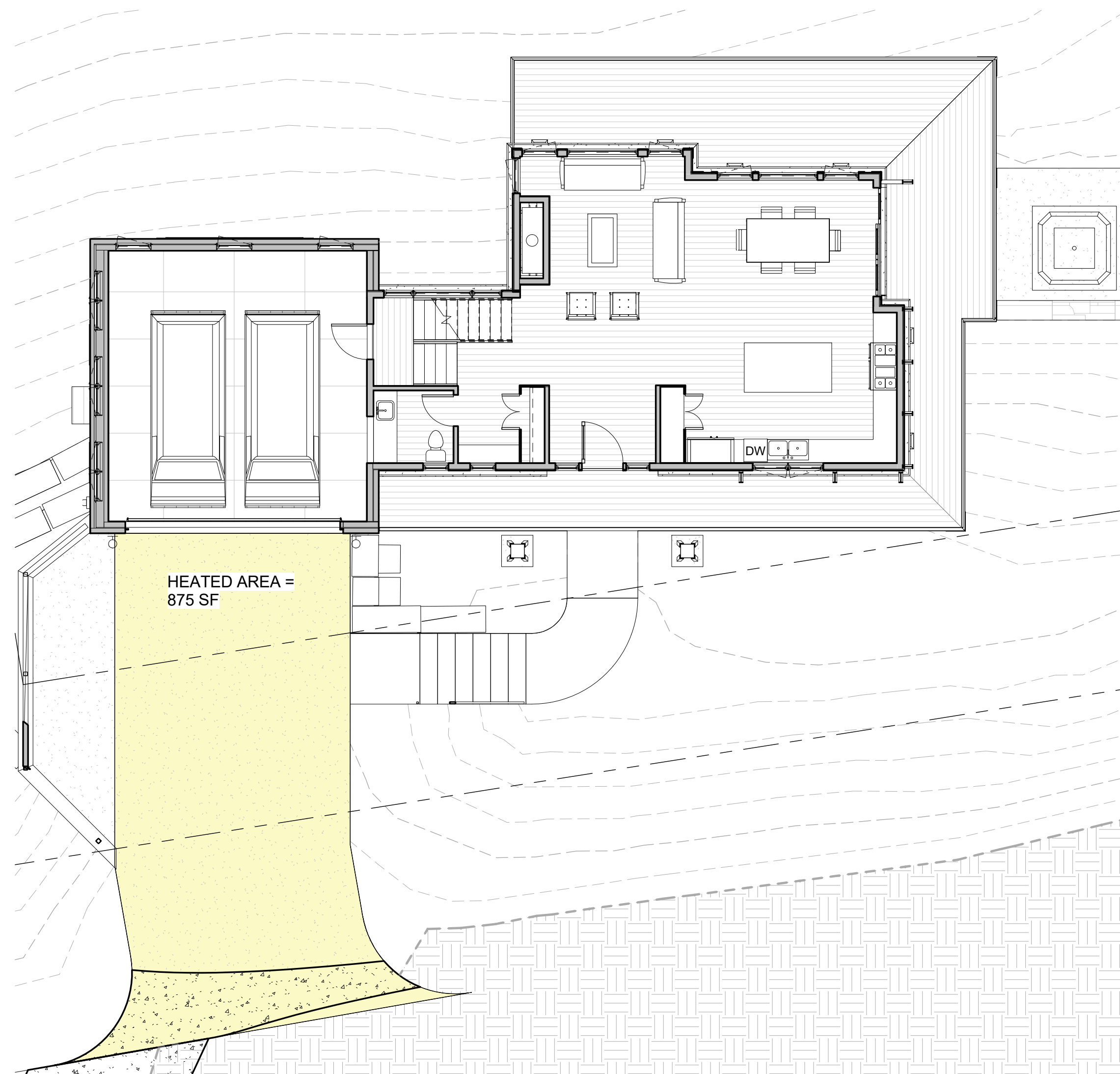
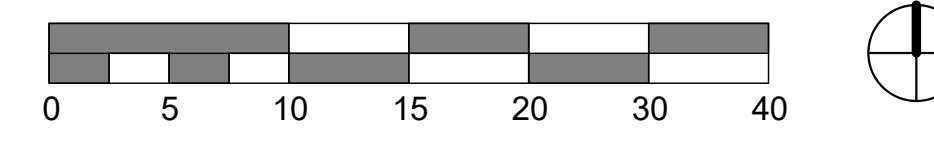

② A105- ENTRY LEVEL SNOW MELT PLAN  
1/8" = 1'-0"

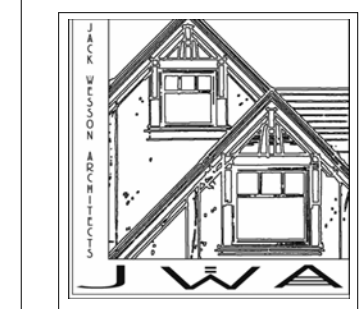
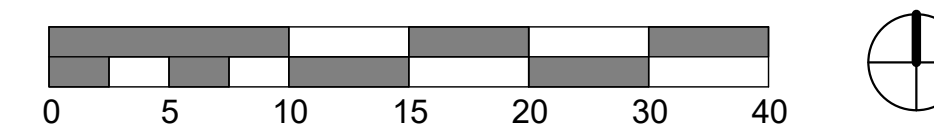

**JACK WESSON**  
ARCHITECTS INC.

TELLURIDE, COLORADO 81435  
TEL: 970.728.9755  
FAX: 970.728.9734  
jack@wessonarch.com  
www.jackwessonarchitects.com

11-30-20	DRB PACKAGE
11-12-20	PLAN REVISIONS
11-7-20	SF HEIGHT LIMIT
10-6-20	DRB PACKAGE
10-2-20	PROGRESS SET
9-29-20	14' SHIFT
9-24-20	PROGRESS SET
9-21-20	DRB DRAFT 1
9-9-20	SD: PROGRESS SET
9-4-20	SD: DESIGN SET
8-19-20	SD: DESIGN SET
8-13-20	SD: DESIGN SET
8-11-20	SD: DESIGN SET
7-29-20	SD: SITE, GRADE
6-1-20	OPTIONS
5-28-20	DESIGN DRAWINGS

PROJECT NAME:  
**LOT BC513E**

MOUNTAIN VILLAGE, COLORADO 81435

SHEET DESCRIPTION:  
**SNOW MELT PLAN**

SHEET NUMBER:  
**A105**

MARK	REV. DATE	DESCRIPTION

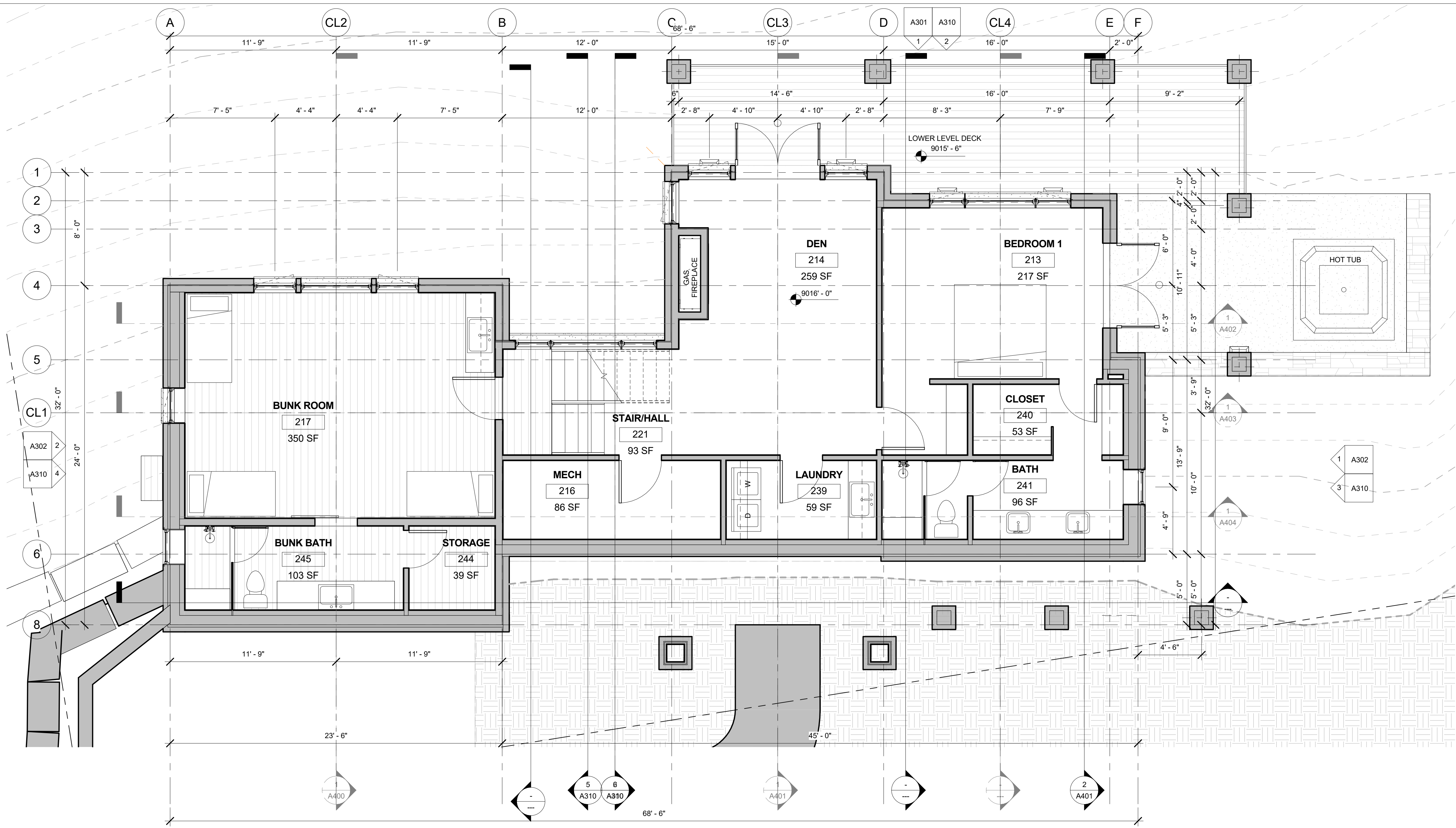

2 A201 BASEMENT  
1/4" = 1'-0"

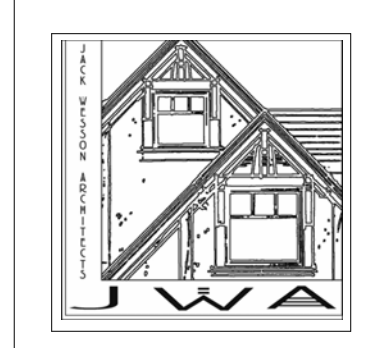
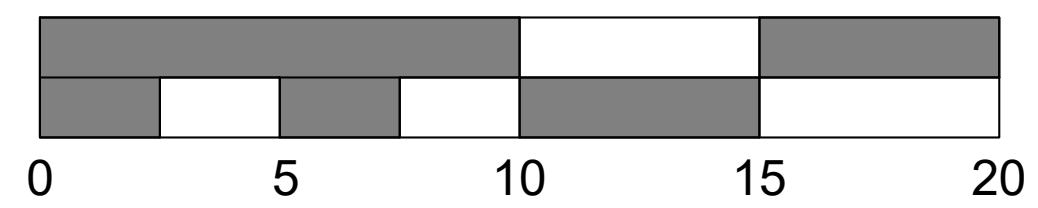
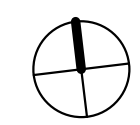

**JACK WESSON**  
ARCHITECTS INC.  
TELLURIDE, COLORADO 81435  
TEL: 970.728.9755  
FAX: 970.728.9754  
jack@wessonarch.com  
www.jackwessonarchitects.com

11-30-20	DRB PACKAGE
11-12-20	PLAN REVISIONS
11-7-20	35' HEIGHT LIMIT
10-6-20	DRB PACKAGE
10-2-20	PROGRESS SET
9-29-20	14' SHIFT
9-24-20	PROGRESS SET
9-21-20	DRB DRAFT 1
9-9-20	SD: PROGRESS SET
9-4-20	SD: DESIGN SET
8-19-20	SD: DESIGN SET
8-13-20	SD: DESIGN SET
8-11-20	SD: DESIGN SET
7-29-20	SD: SITE, GRADE
6-1-20	OPTIONS
5-28-20	DESIGN DRAWINGS

PROJECT NAME:  
LOT BC513E  
MOUNTAIN VILLAGE, COLORADO 81435  
SHEET DESCRIPTION:  
**BASEMENT PLAN**  
SHEET NUMBER:  
**A201**

MARK	REV DATE	DESCRIPTION
PROJECT NAME		
PROJECT MANAGER		
DRAWN BY		
REVIEWED BY		
© 2022 JWA		

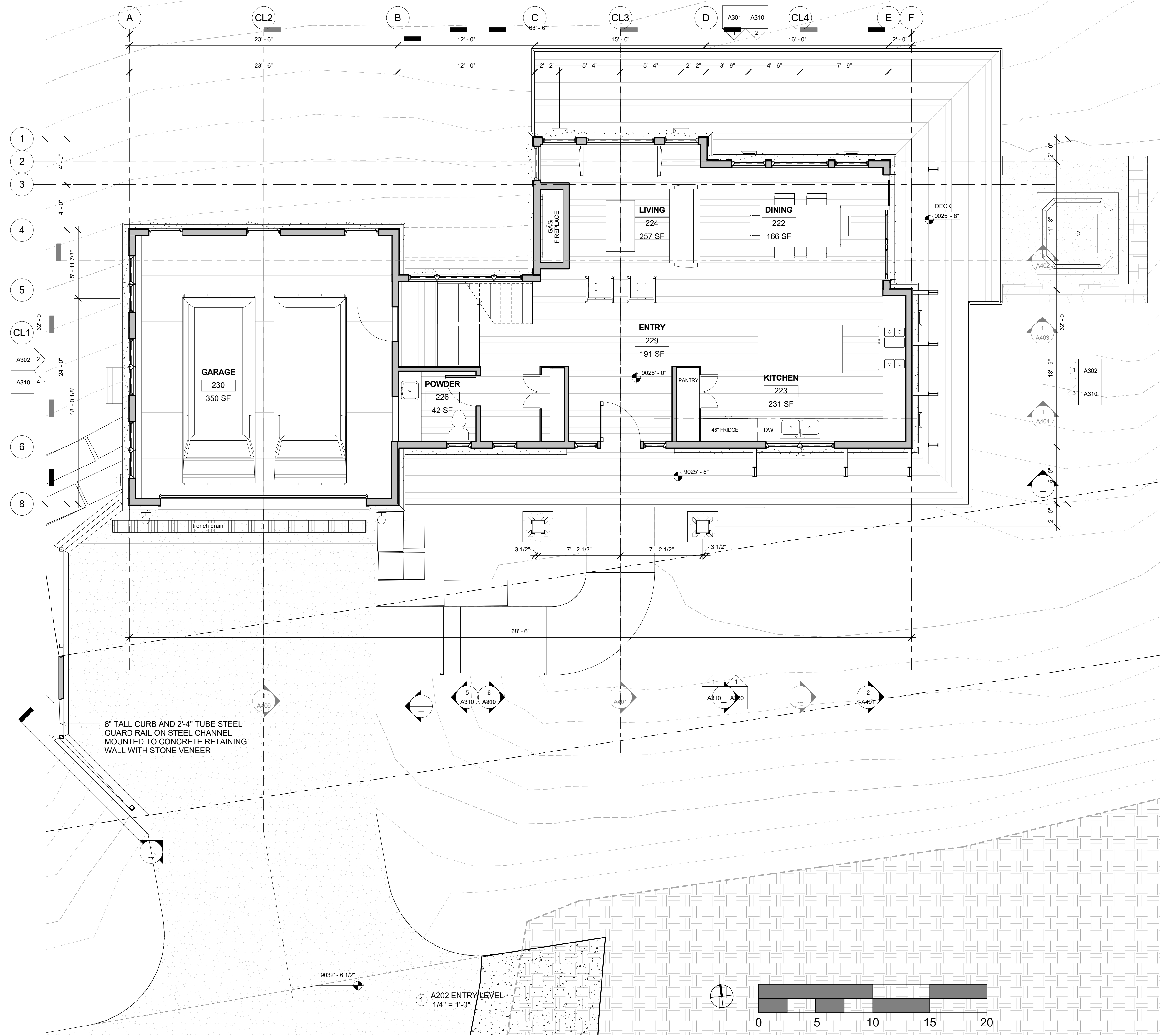

8" TALL CURB AND 2-4" TUBE STEEL  
 GUARD RAIL ON STEEL CHANNEL  
 MOUNTED TO CONCRETE RETAINING  
 WALL WITH STONE VENEER

1 A202 ENTRY LEVEL  
 1/4" = 1'-0"

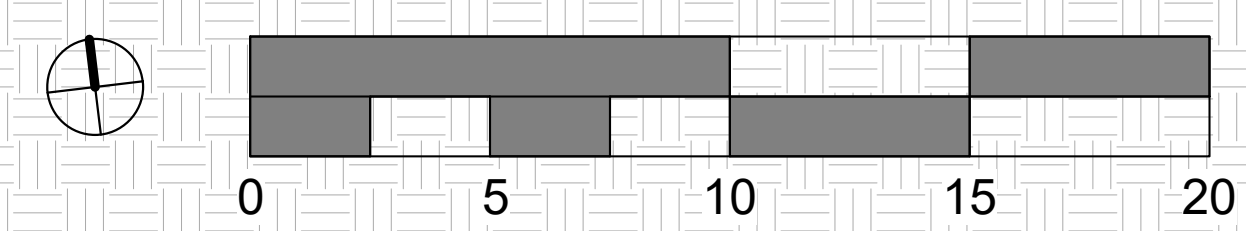

**JACK WESSON**  
 ARCHITECTS INC.

TELLURIDE, COLORADO 81435  
 TEL: 970.728.9755  
 FAX: 970.728.9754  
 jack@wessonarch.com  
 www.jackwessonarchitects.com

MARK	REV. DATE	DESCRIPTION
	11-30-20	DRB PACKAGE
	11-12-20	PLAN REVISIONS
	11-7-20	35' HEIGHT LIMIT
	10-6-20	DRB PACKAGE
	10-2-20	PROGRESS SET
	9-29-20	14' SHIFT
	9-24-20	PROGRESS SET
	9-21-20	DRB DRAFT 1
	9-9-20	SD: PROGRESS SET
	9-4-20	SD: DESIGN SET
	8-19-20	SD: DESIGN SET
	8-13-20	SD: DESIGN SET
	8-11-20	SD: DESIGN SET
	7-29-20	SD: SITE, GRADE
	6-1-20	OPTIONS
	5-28-20	DESIGN DRAWINGS

PROJECT NAME:  
**LOT BC513E**

MOUNTAIN VILLAGE, COLORADO 81435

SHEET DESCRIPTION:  
**ENTRY LEVEL PLAN**

SHEET NUMBER:  
**A202**

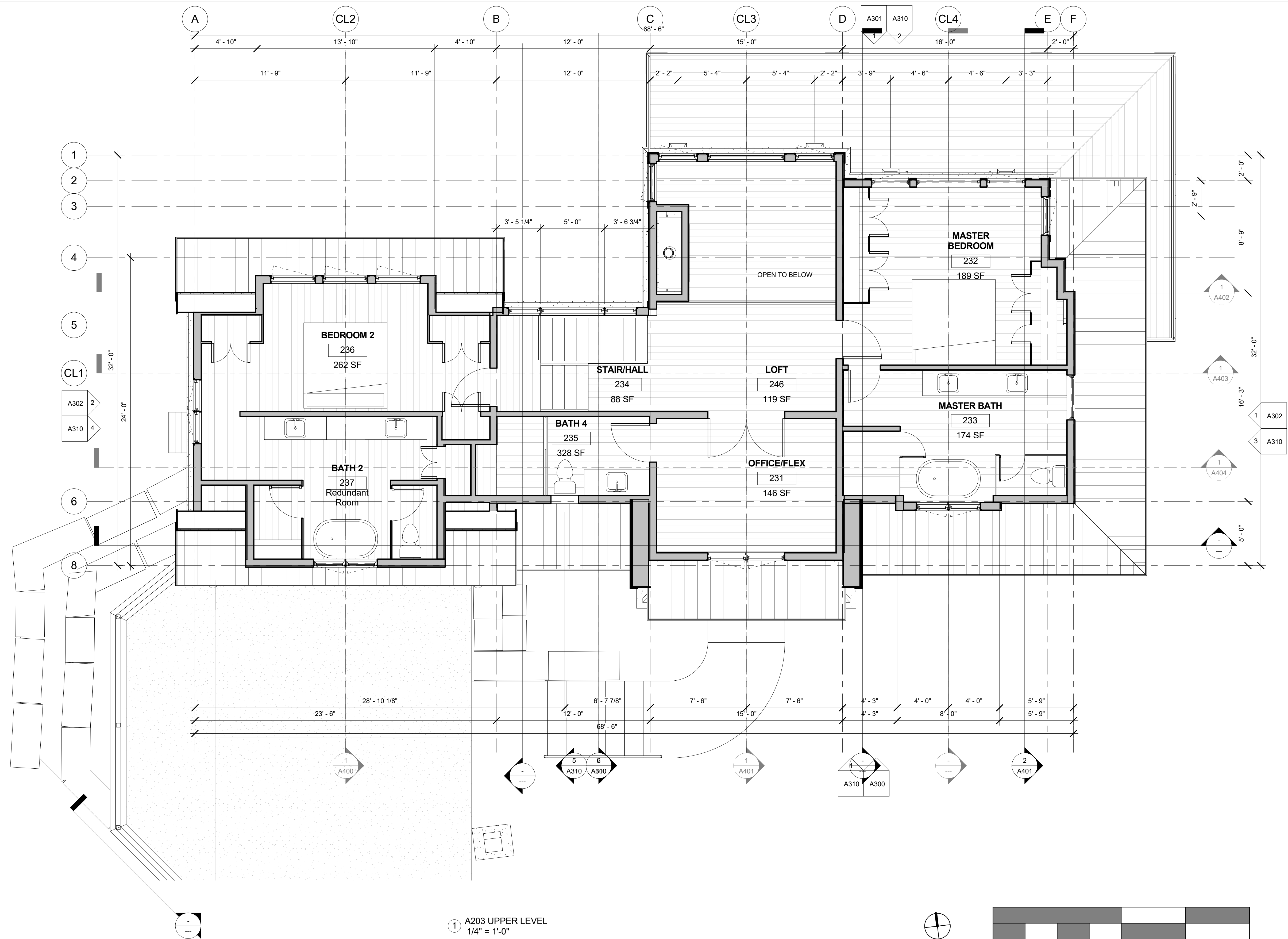

1 A203 UPPER LEVEL  
1/4" = 1'-0"

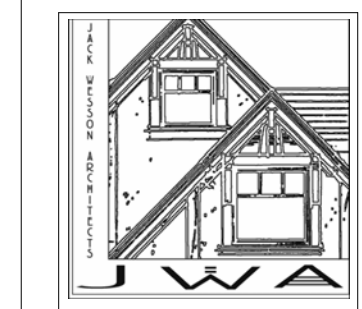

**JACK WESSON**  
ARCHITECTS INC.

TELLURIDE, COLORADO 81435  
TEL: 970.728.9755  
FAX: 970.728.9754  
jack@wessonarch.com  
www.jackwessonarchitects.com

11-30-20	DRB PACKAGE
11-12-20	PLAN REVISIONS
11-7-20	35' HEIGHT LIMIT
10-6-20	DRB PACKAGE
10-2-20	PROGRESS SET
9-29-20	14' SHIFT
9-24-20	PROGRESS SET
9-21-20	DRB DRAFT 1
9-9-20	SD: PROGRESS SET
9-4-20	SD: DESIGN SET
8-18-20	SD: DESIGN SET
8-13-20	SD: DESIGN SET
8-11-20	SD: DESIGN SET
7-29-20	SD: SITE, GRADE
6-1-20	OPTIONS
5-28-20	DESIGN DRAWINGS

PROJECT NAME:  
**LOT BC513E**  
MOUNTAIN VILLAGE, COLORADO 81435

SHEET DESCRIPTION:  
**UPPER LEVEL PLAN**

MARK	REV. DATE	DESCRIPTION

SHEET NUMBER:  
**A203**

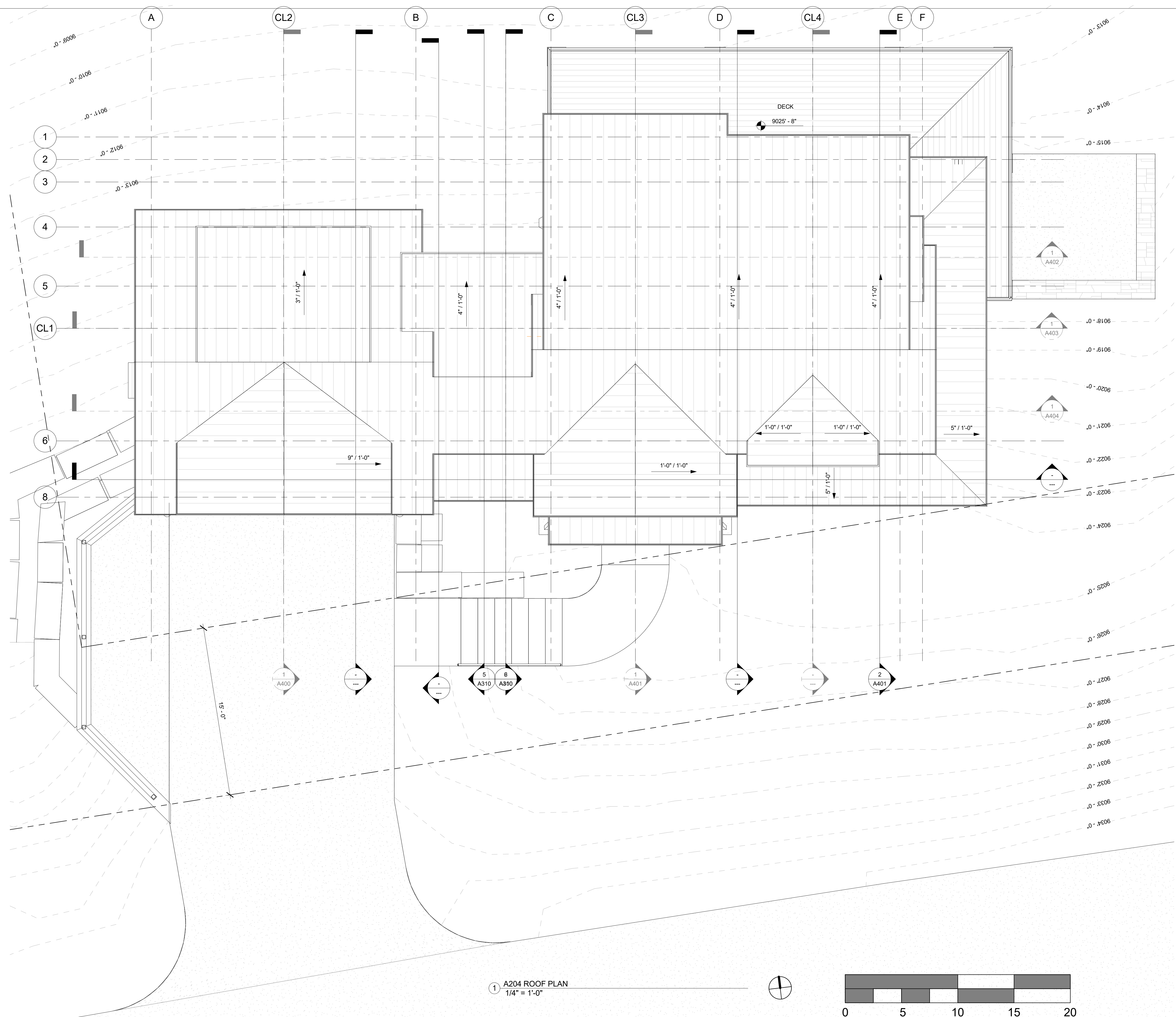

1 A204 ROOF PLAN  
1/4" = 1'-0"

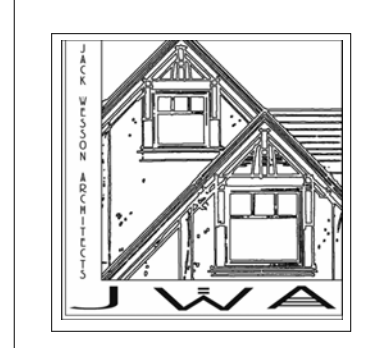
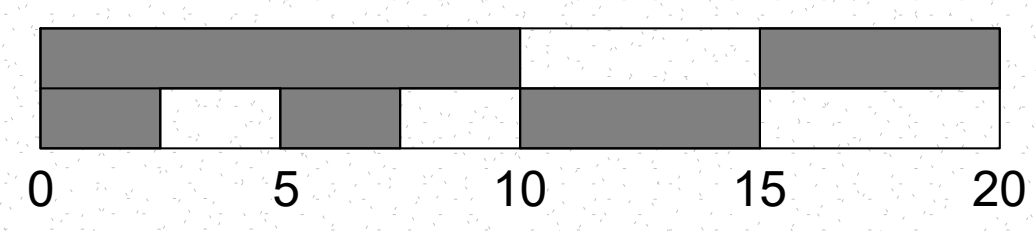

**JACK WESSON**  
ARCHITECTS INC.  
TELLURIDE, COLORADO 81435  
TEL: 970.728.9755  
FAX: 970.728.9754  
jack@wessonarch.com  
www.jackwessonarchitects.com

MARK	REV. DATE	DESCRIPTION
11-30-20	DRB PACKAGE	
11-12-20	PLAN REVISIONS	
11-7-20	32' HEIGHT LIMIT	
10-6-20	DRB PACKAGE	
10-2-20	PROGRESS SET	
9-29-20	14' SHIFT	
9-24-20	PROGRESS SET	
9-21-20	DRB DRAFT 1	
9-9-20	SD: PROGRESS SET	
9-4-20	SD: DESIGN SET	
8-19-20	SD: DESIGN SET	
8-13-20	SD: DESIGN SET	
8-11-20	SD: DESIGN SET	
7-29-20	SD: SITE, GRADE	
6-1-20	OPTIONS	
5-28-20	DESIGN DRAWINGS	

PROJECT NAME: LOT BC513E  
MOUNTAIN VILLAGE, COLORADO 81435  
SHEET DESCRIPTION: ROOF PLAN  
SHEET NUMBER: A204

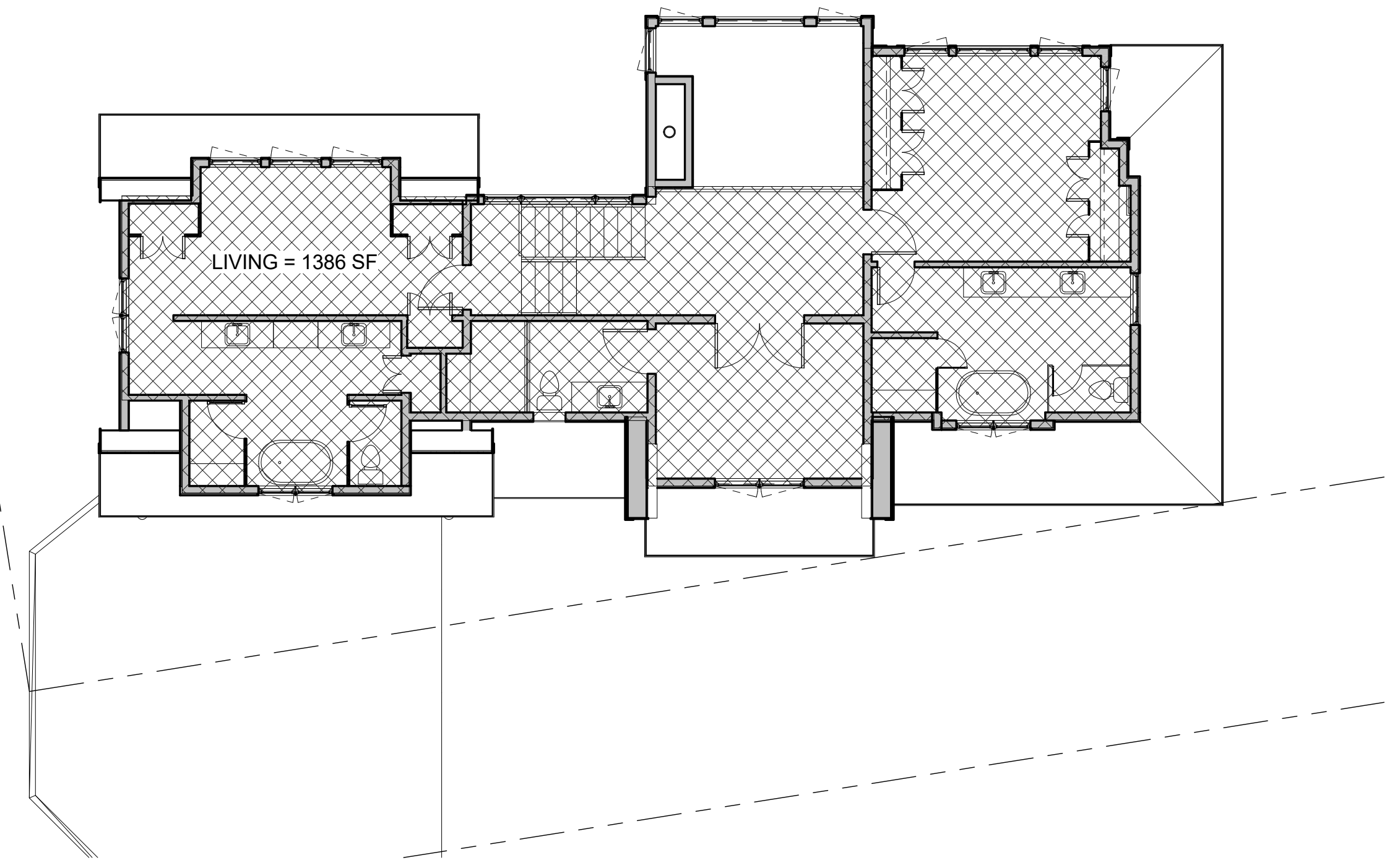

3 AREA PLAN 3 UPPER LEVEL  
1/8" = 1'-0"

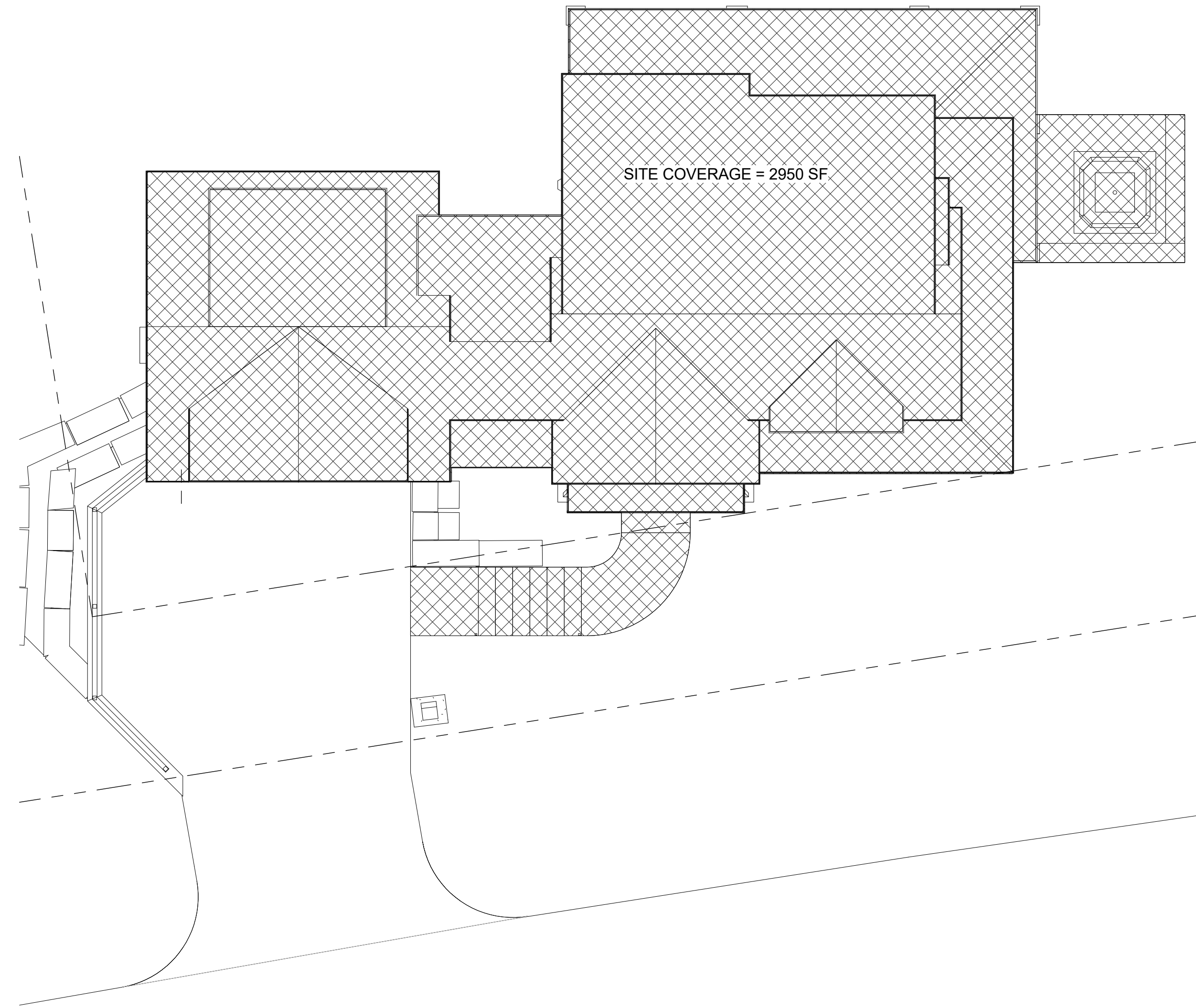

4 AREA PLAN 4 SITE COVERAGE  
1/8" = 1'-0"

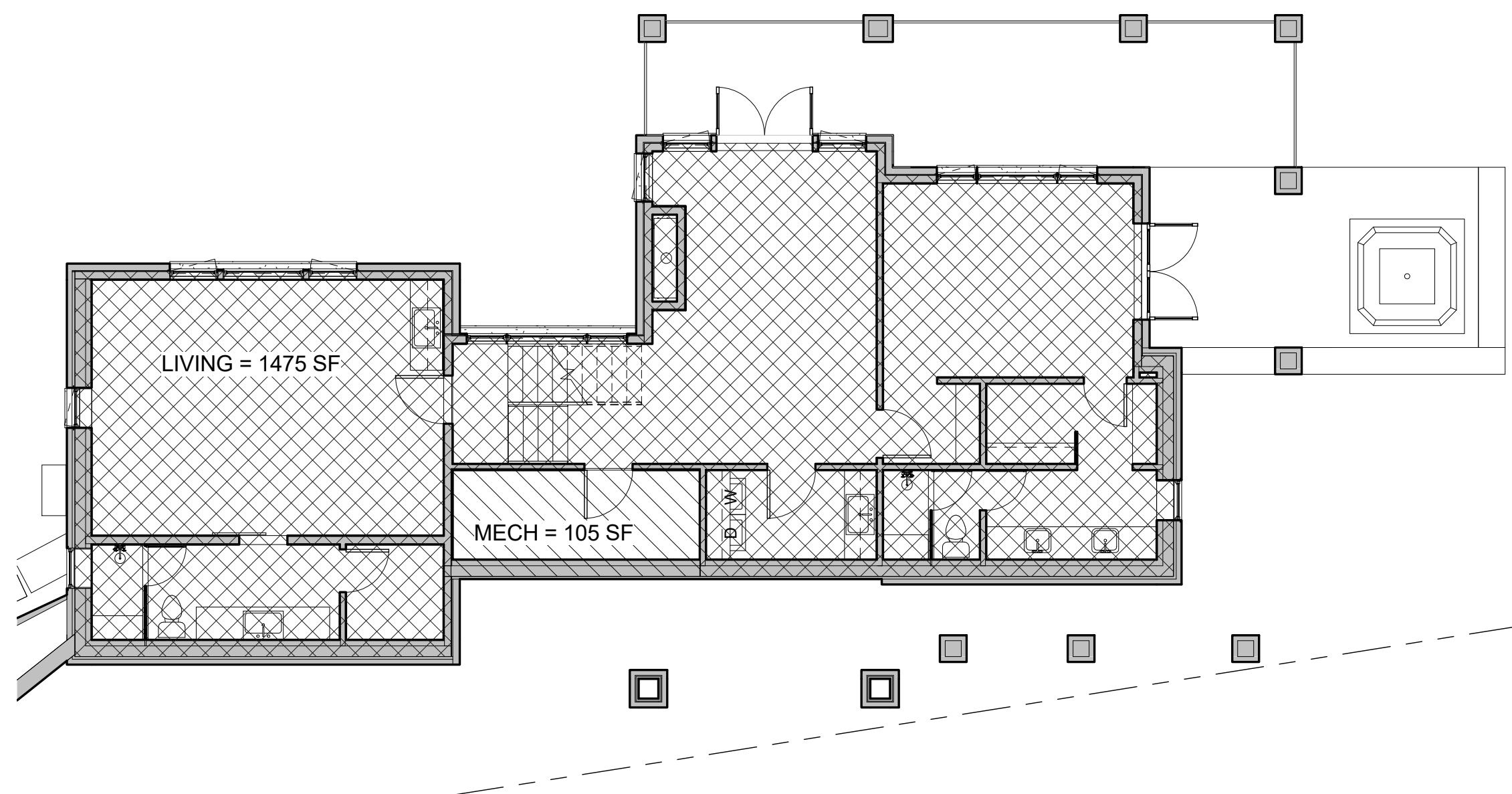

1 AREA PLAN 1 BASEMENT  
1/8" = 1'-0"

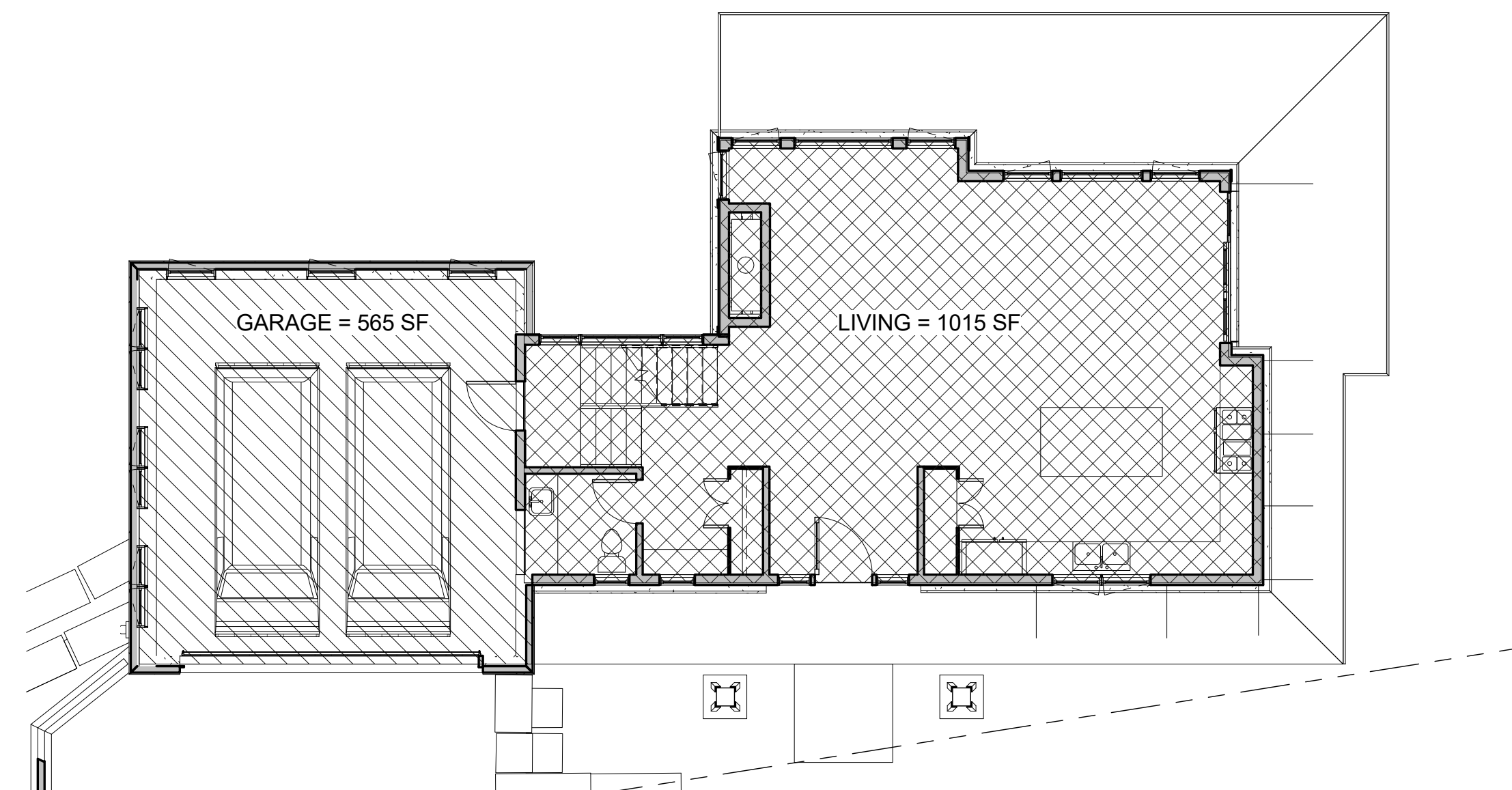

2 AREA PLAN 2 ENTRY LEVEL  
1/8" = 1'-0"

BUILDING FOOTPRINT : 2950 SF  
TOTAL LOT AREA : 26,000 SF  
SITE COVERAGE : 11.3 %

BASEMENT LEVEL:  
LIVING = 1475 SF  
MECH = 105 SF

ENTRY LEVEL:  
LIVING = 1015 SF  
GARAGE = 565 SF

UPPER LEVEL:  
LIVING = 1386 SF

TOTAL LIVING = 3876 SF

TOTAL GROSS = 4546 SF

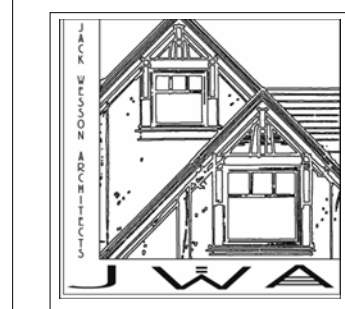

**JACK WESSON**  
ARCHITECTS INC.

TELLURIDE, COLORADO 81435  
TEL: 970.728.9755  
FAX: 970.728.9754  
jack@wessonarch.com  
www.jackwessonarchitects.com

11-30-20	DRB PACKAGE
11-12-20	PLAN REVISIONS
11-7-20	30' HEIGHT LIMIT
10-6-20	DRB PACKAGE
10-2-20	PROGRESS SET
9-29-20	14' SHIFT
9-24-20	PROGRESS SET
9-21-20	DRB DRAFT 1
9-9-20	SD: PROGRESS SET
9-4-20	SD: DESIGN SET
8-19-20	SD: DESIGN SET
8-13-20	SD: DESIGN SET
8-11-20	SD: DESIGN SET
7-29-20	SD: SITE, GRADE
6-1-20	OPTIONS
5-28-20	DESIGN DRAWINGS

MARK REV. DATE DESCRIPTION  
PROJECT MANAGER:  
DRAWN BY:  
REVIEWED BY:  
© 2020 JWA

PROJECT NAME:  
**LOT BC513E**  
MOUNTAIN VILLAGE, COLORADO 81435

SHEET DESCRIPTION:  
**GROSS BUILDING AREA**

SHEET NUMBER:  
**A210**



1 SOUTH ELEVATION  
1/4" = 1'-0"

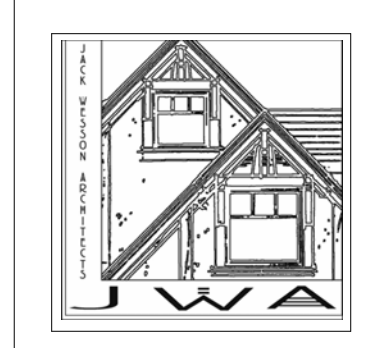
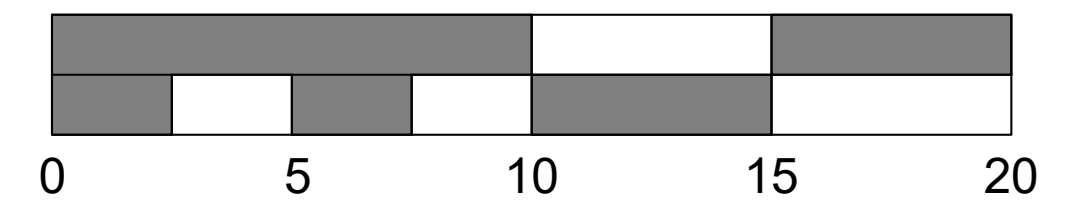

**JACK WESSON**  
ARCHITECTS INC.  
TELLURIDE, COLORADO 81435  
TEL: 970.728.9755  
FAX: 970.728.9734  
jack@wessonarch.com  
www.jackwessonarchitects.com

11-30-20	DRB PACKAGE
11-12-20	PLAN REVISIONS
11-7-20	35' HEIGHT LIMIT
10-6-20	DRB PACKAGE
10-2-20	PROGRESS SET
9-29-20	14' SHIFT
9-24-20	PROGRESS SET
9-21-20	DRB DRAFT 1
9-9-20	SD: PROGRESS SET
9-4-20	SD: DESIGN SET
8-19-20	SD: DESIGN SET
8-13-20	SD: DESIGN SET
8-11-20	SD: DESIGN SET
7-29-20	SD: SITE, GRADE
6-1-20	OPTIONS
5-28-20	DESIGN DRAWINGS

PROJECT NAME:  
**LOT BC513E**  
MOUNTAIN VILLAGE, COLORADO 81435  
SHEET DESCRIPTION:  
**ELEVATIONS**  
SHEET NUMBER:  
**A300**

MARK	REV	DATE	DESCRIPTION

PROJECT NAME:  
PROJECT MANAGER:  
DRAWN BY:  
REVIEWED BY:  
© 2022 JWA  
PraisRegular





① 2 NORTH ELEVATION  
1/4" = 1'-0"

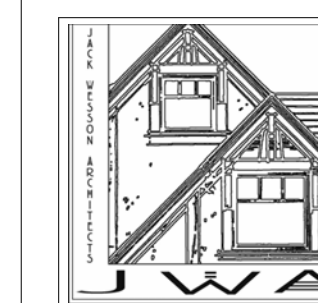
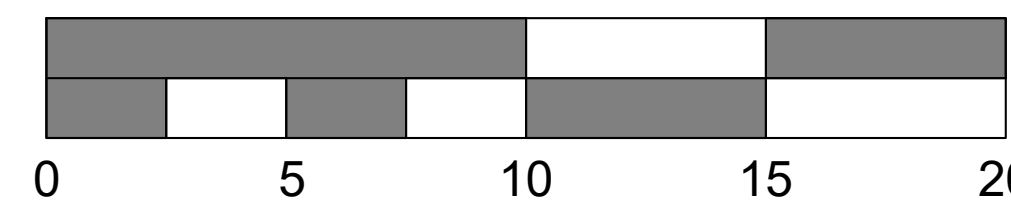

**JACK WESSON**  
ARCHITECTS INC.

TELLURIDE, COLORADO 81435  
TEL: 970.728.9755  
FAX: 970.728.9734  
jack@wessonarch.com  
www.jackwessonarchitects.com

11-30-20	DRB PACKAGE
11-12-20	PLAN REVISIONS
11-7-20	35' HEIGHT LIMIT
10-6-20	DRB PACKAGE
10-2-20	PROGRESS SET
9-29-20	14' SHIFT
9-24-20	PROGRESS SET
9-21-20	DRB DRAFT 1
9-9-20	SD: PROGRESS SET
9-4-20	SD: DESIGN SET
8-18-20	SD: DESIGN SET
8-13-20	SD: DESIGN SET
8-11-20	SD: DESIGN SET
7-29-20	SD: SITE, GRADE
6-1-20	OPTIONS
5-28-20	DESIGN DRAWINGS

MARK	REV. DATE	DESCRIPTION
------	-----------	-------------

PROJECT NAME:  
PROJECT MANAGER:  
DRAWN BY:  
REVIEWED BY:  
© 2022 JWA

PROJECT NAME:  
**LOT BC513E**

MOUNTAIN VILLAGE, COLORADO 81435

SHEET DESCRIPTION:  
**ELEVATIONS**

SHEET NUMBER:  
**A301**

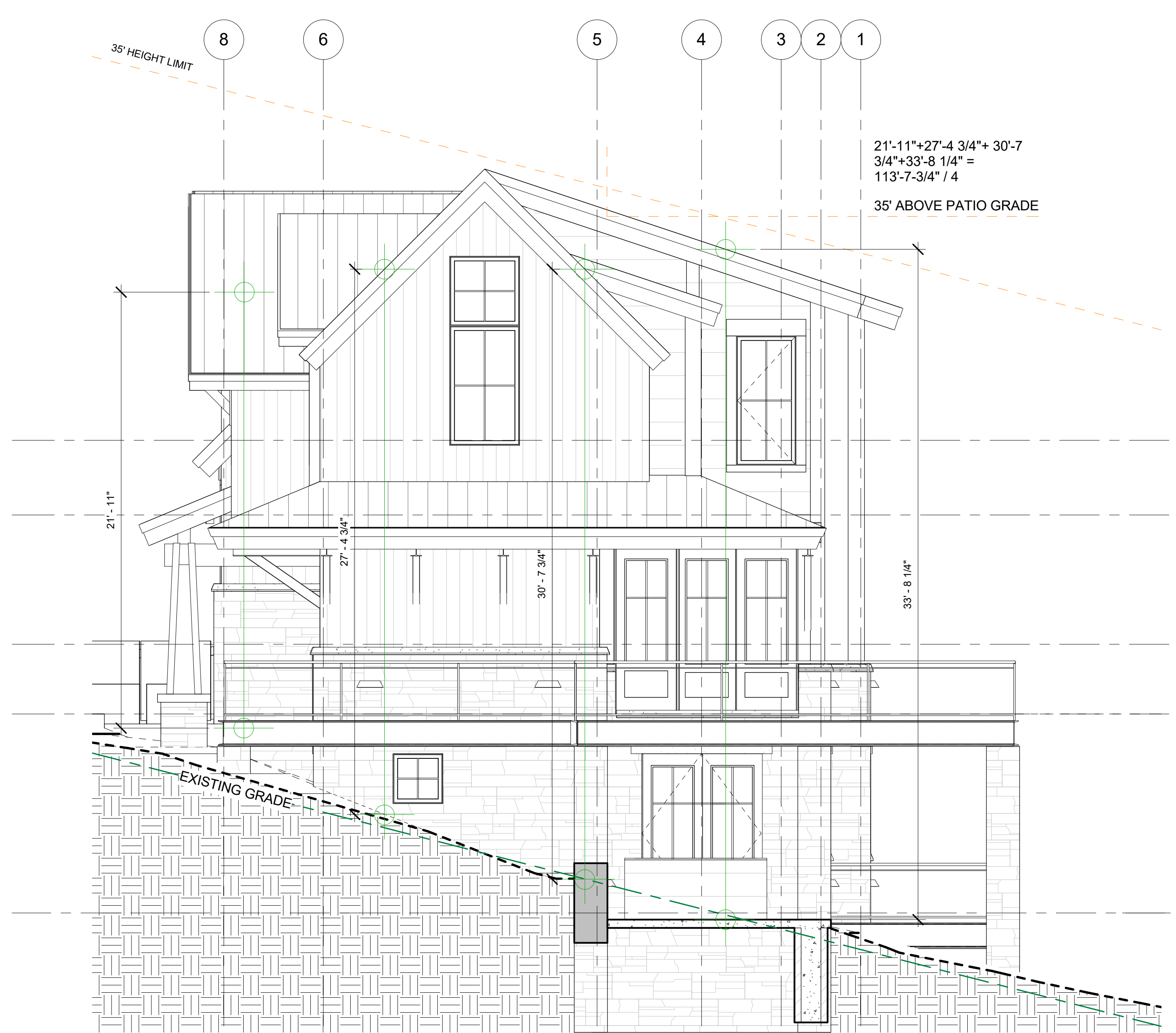

① 3 EAST ELEVATION  
1/4" = 1'-0"

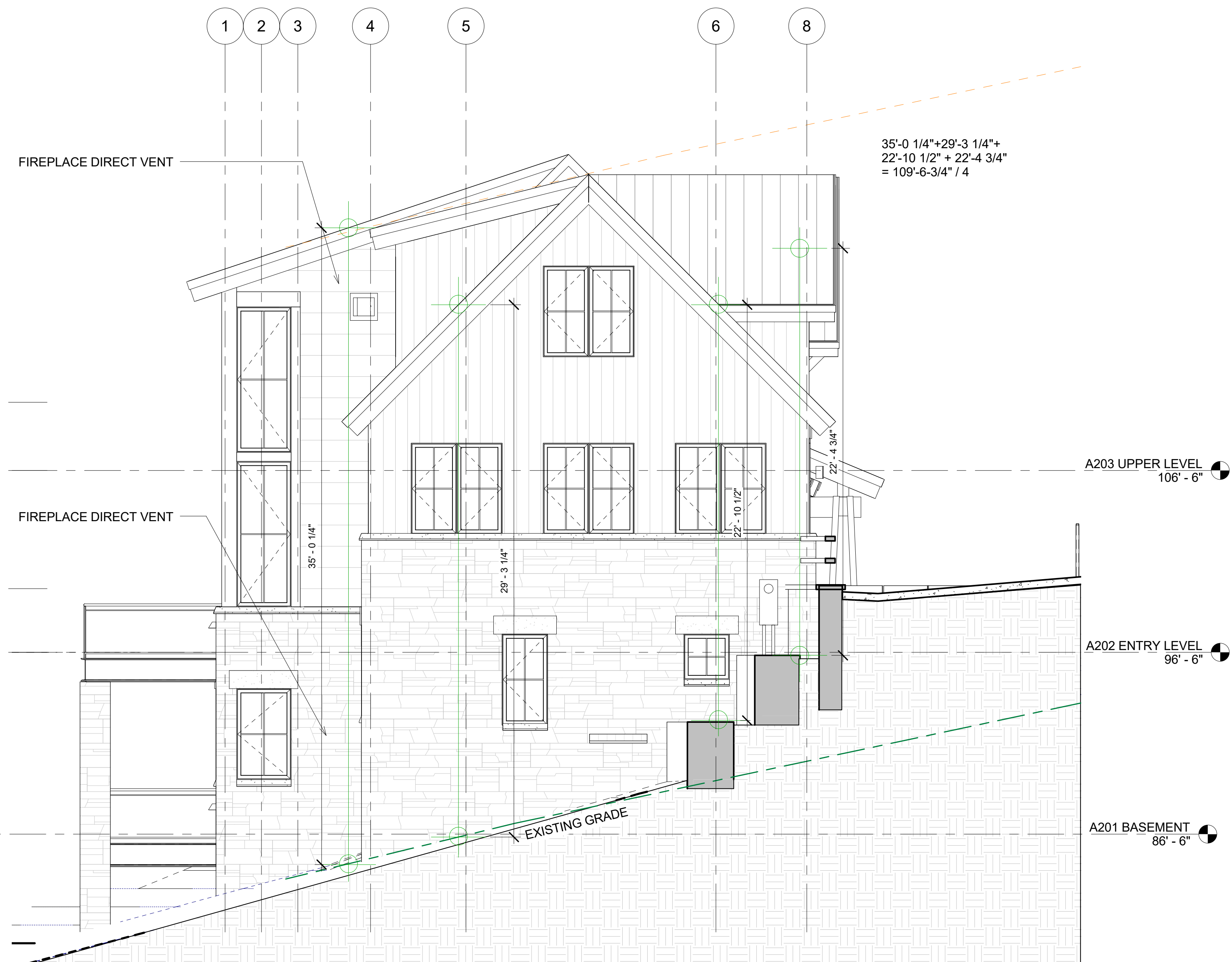
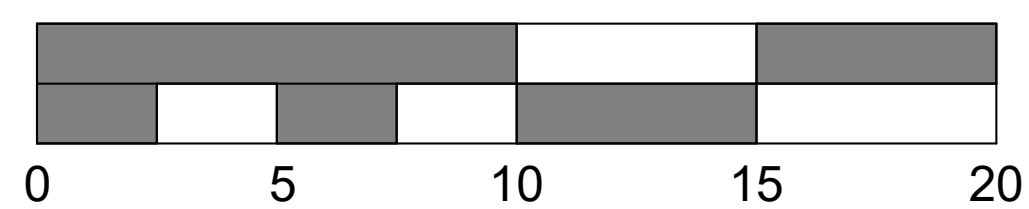

② 4 WEST ELEVATION  
1/4" = 1'-0"

**AVERAGE BUILDING HEIGHT CALC:**  
 (6) SOUTH 122'-10"  
 (4) EAST 113'-7 3/4"  
 (5) NORTH 167'-7"  
 (4) WEST 109'-6 3/4"

513'-7 1/2"/19= 27'-0 1/2" (30' max)



**JACK WESSON**  
ARCHITECTS INC.

TELLURIDE, COLORADO 81435  
 TEL: 970.728.9755  
 FAX: 970.728.9754  
 jack@wessonarch.com  
 www.jackwessonarchitects.com

11-30-20	DRB PACKAGE
11-12-20	PLAN REVISIONS
11-7-20	35' HEIGHT LIMIT
10-6-20	DRB PACKAGE
10-2-20	PROGRESS SET
9-29-20	14' SHIFT
9-24-20	PROGRESS SET
9-21-20	DRB DRAFT 1
9-9-20	SD: PROGRESS SET
9-4-20	SD: DESIGN SET
8-19-20	SD: DESIGN SET
8-13-20	SD: DESIGN SET
8-11-20	SD: DESIGN SET
7-29-20	SD: SITE, GRADE
6-1-20	OPTIONS
5-28-20	DESIGN DRAWINGS

PROJECT NAME:  
LOT BC513E

MOUNTAIN VILLAGE, COLORADO 81435

SHEET DESCRIPTION:  
ELEVATIONS

SHEET NUMBER:  
A302

MARK	REV DATE	DESCRIPTION

PROJECT NAME:  
PROJECT MANAGER:  
DRAWN BY:  
REVIEWED BY:  
© 2022 AIA

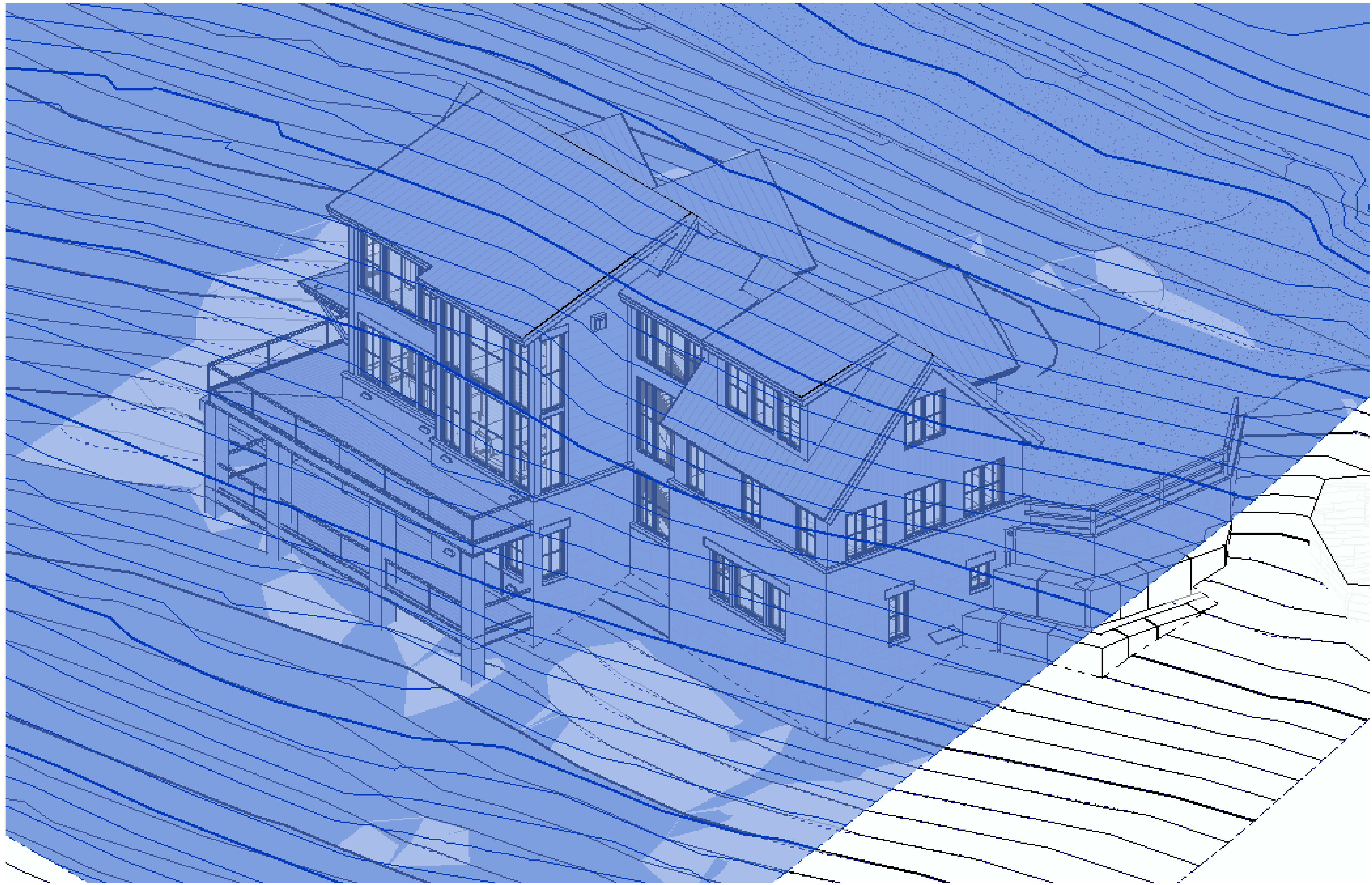

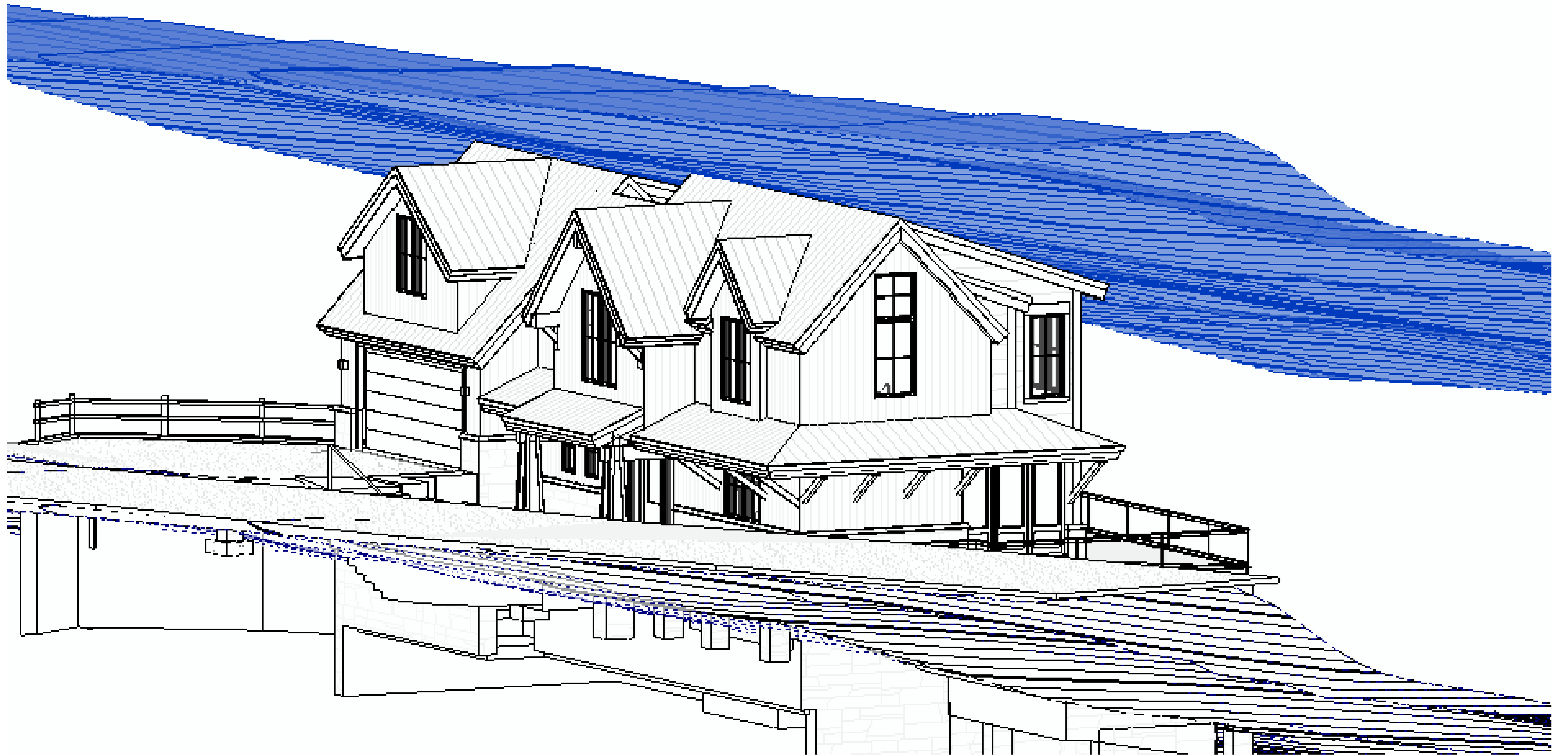

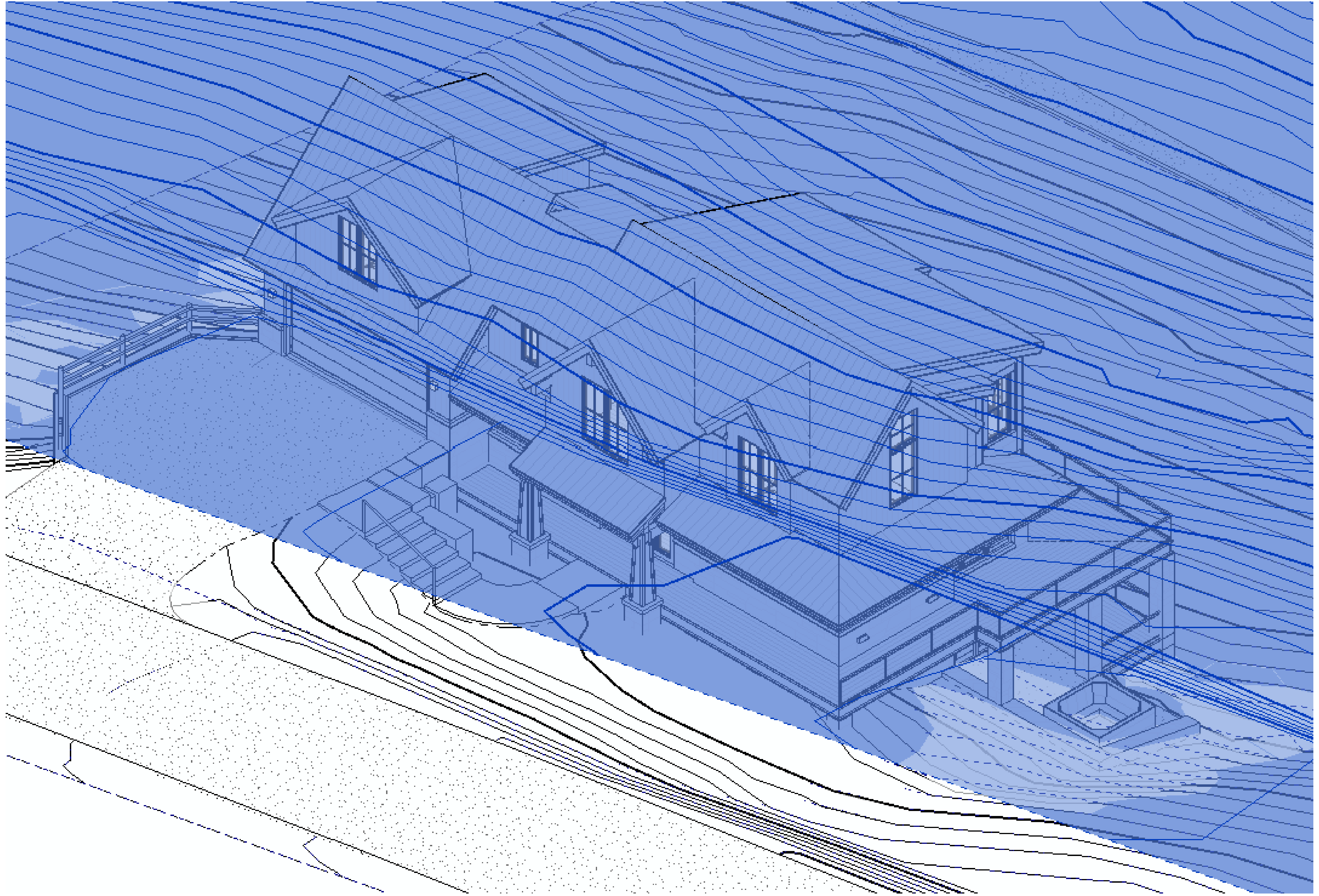

WEST ELEVATION 2  
 STONE = 540 SF  
 WOOD = 420 SF  
 GLAZING = 95 SF  
 ACCENT = 45 SF



6 MATERIAL CALC WEST 2  
 1/8" = 1'-0"

WEST ELEVATION  
 STONE = 500 SF  
 WOOD = 295 SF  
 GLAZING = 120 SF  
 ACCENT = 48 SF



4 MATERIAL CALC 4 WEST ELEVATION  
 1/8" = 1'-0"

NORTH ELEVATION  
 STONE = 1266 SF  
 WOOD = 533 SF  
 GLAZING = 800 SF  
 ACCENT = 280 SF.



2 MATERIAL CALC 2 NORTH ELEVATION  
 1/8" = 1'-0"

EAST ELEVATION 2  
 STONE = 105 SF  
 WOOD = 140 SF  
 GLAZING = 0 SF  
 ACCENT = 0 SF



5 MATERIAL CALC EAST 2  
 1/8" = 1'-0"

EAST ELEVATION  
 STONE = 420 SF  
 WOOD = 457 SF  
 GLAZING = 113 SF  
 ACCENT = 250 SF.

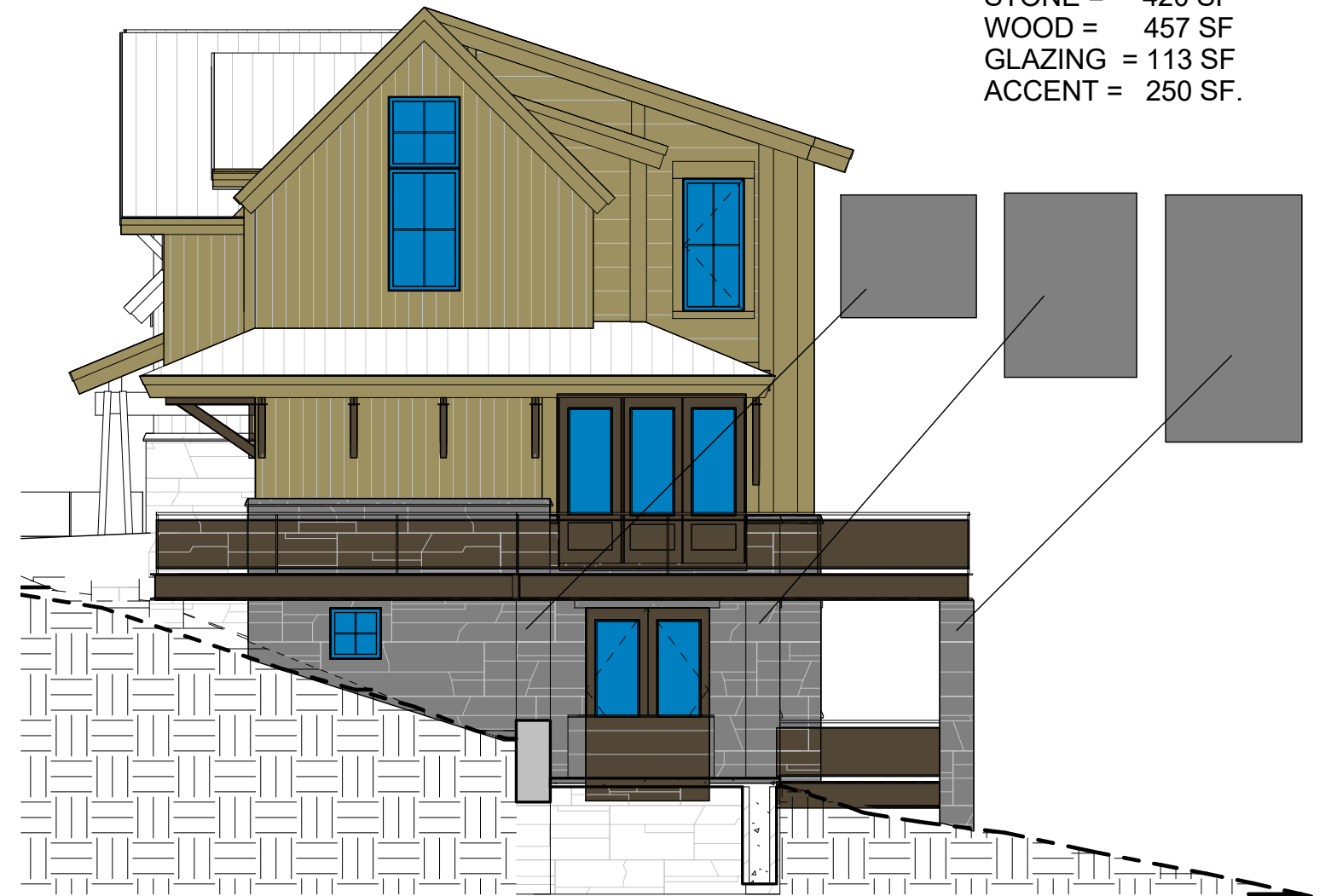

3 MATERIAL CALC 3 EAST ELEVATION  
 1/8" = 1'-0"

SOUTH ELEVATION  
 STONE = 215 SF  
 WOOD = 700 SF  
 GLAZING = 200 SF  
 ACCENT = 230 SF.



1 MATERIAL CALC 1 SOUTH ELEVATION  
 1/8" = 1'-0"

BC513E- Material Calculations									
Elevation	South	East 1	East 2	North	West 1	West 2	Total	Percent	
Stone	215	420	105	1266	500	540	3046	38.97%	
Wood	700	457	140	533	295	420	2545	32.56%	
Fenestration	200	113	0	800	120	95	1328	16.99%	
Accent	230	250	45	280	48	45	898	11.49%	
<b>Total</b>	<b>1345</b>	<b>1240</b>	<b>290</b>	<b>2879</b>	<b>963</b>	<b>1100</b>	<b>7817</b>		



**JACK WESSON**  
 ARCHITECTS INC.

TELLURIDE, COLORADO 81435  
 TEL: 970.728.9755  
 FAX: 970.728.9754  
 jack@wessonarch.com  
 www.jackwessonarchitects.com

MARK	REV	DATE	DESCRIPTION
11-30-20	DRB PACKAGE		
11-12-20	PLAN REVISIONS		
11-7-20	32' HEIGHT LIMIT		
10-6-20	DRB PACKAGE		
10-2-20	PROGRESS SET		
9-29-20	14' SHIFT		
9-24-20	PROGRESS SET		
9-21-20	DRB DRAFT 1		
9-9-20	SD: PROGRESS SET		
9-4-20	SD: DESIGN SET		
8-19-20	SD: DESIGN SET		
8-13-20	SD: DESIGN SET		
8-11-20	SD: DESIGN SET		
7-29-20	SD: SITE, GRADE		
6-1-20	OPTIONS		
5-28-20	DESIGN DRAWINGS		

PROJECT NAME:  
 LOT BC513E  
 MOUNTAIN VILLAGE, COLORADO 81435

SHEET DESCRIPTION:  
 MATERIAL CALCS

SHEET NUMBER:  
**A310**

PROJECT MANAGER:  
 DRAWN BY:  
 REVIEWED BY:  
 © 2022 JWA

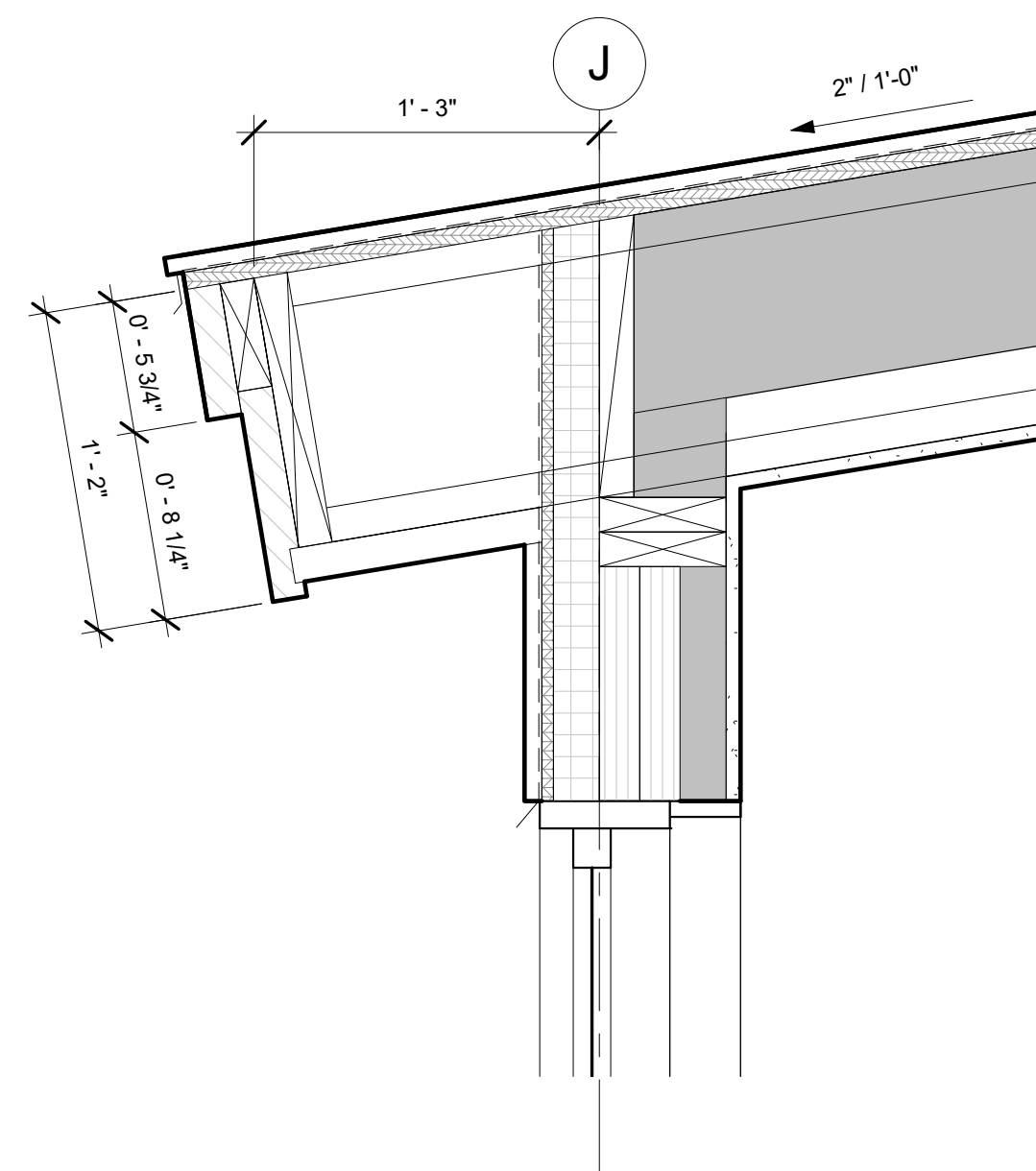

③ DETAIL- ROOF EAVE LOWER  
1 1/2" = 1'-0"

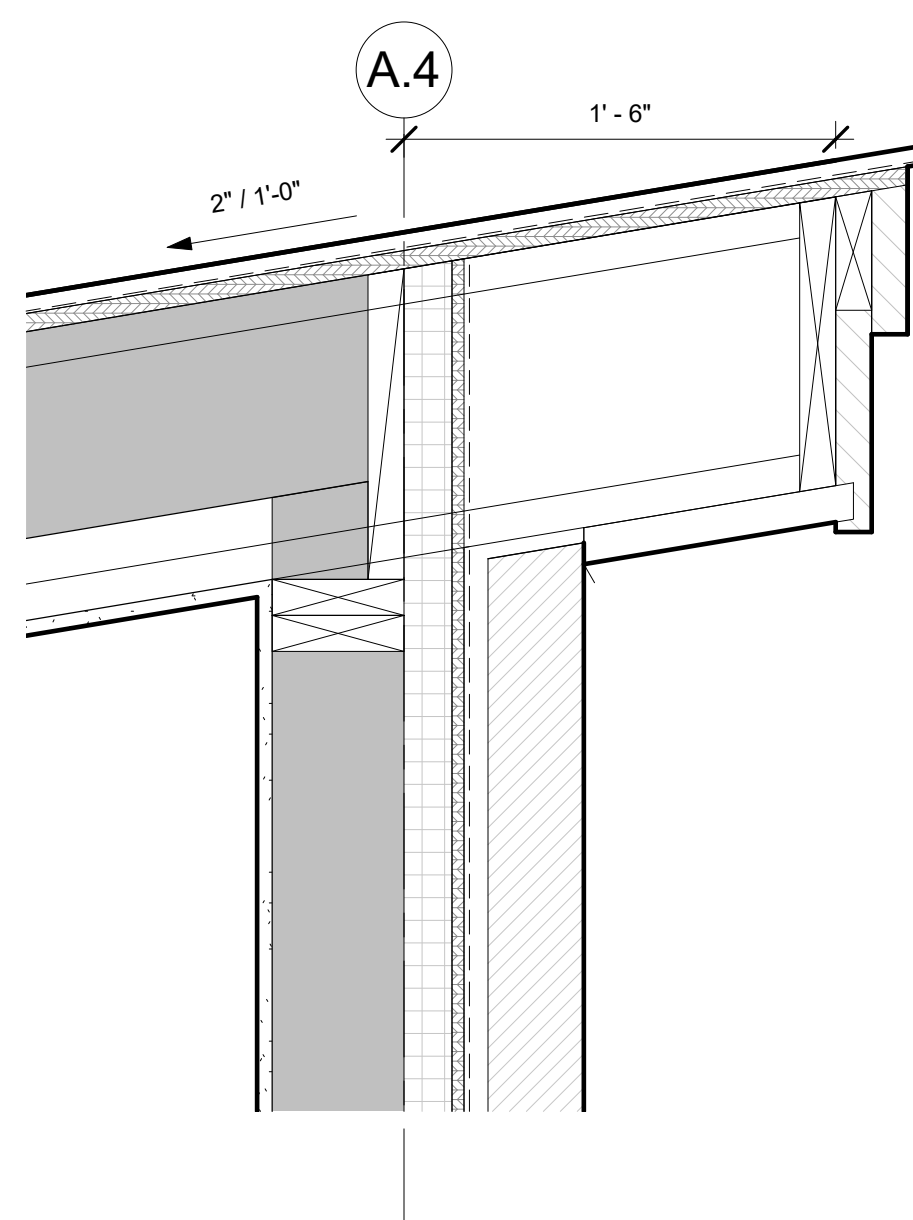

② DETAIL- ROOF EAVE UPPER  
1 1/2" = 1'-0"

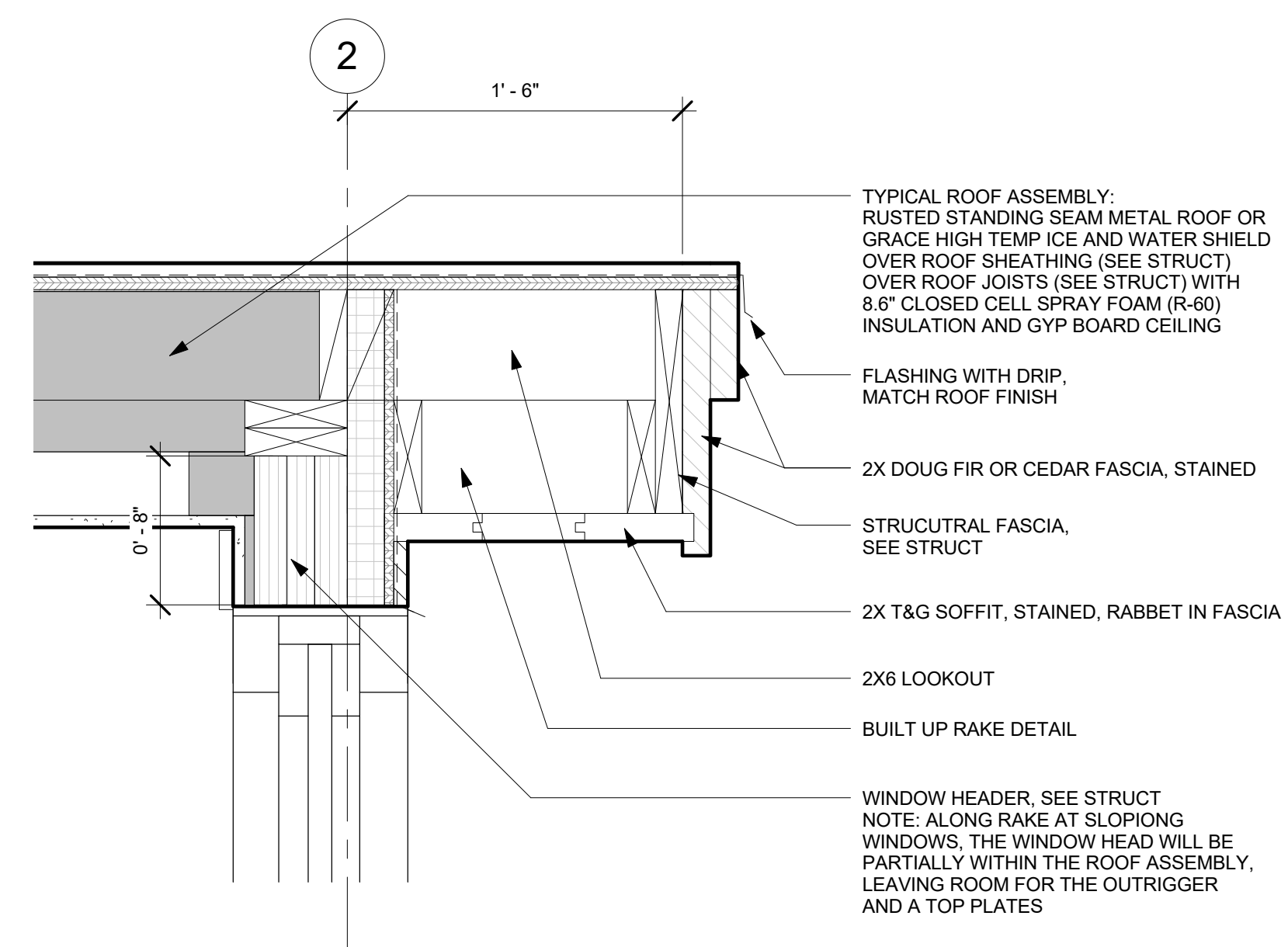

① DETAIL- ROOF RAKE  
1 1/2" = 1'-0"

TYPICAL ROOF DETAILS



**JACK WESSON**  
ARCHITECTS INC.  
110 SOUTH PINE ST #100  
TELLURIDE, COLORADO  
81435  
TEL: 970.728.6755  
FAX:  
970.728.9724  
jwesson@jwma.com  
www.jackwessonarchitects.com

NOT FOR  
CONSTRUCTION

10-9-19	DRB CONDITIONS	
9-23-19	DRB CONDITIONS	
9-9-19	PROGRESS SET	
8-26-19	BUILDING SECTIONS	
8-22-19	SCHEDULES	
8-6-19	ROTATED & SHIFTED	
7-29-19	DRB PACKAGE	
4-25-19	REVIT 3D	
MARK	REV DATE	DESCRIPTION

PROJECT NAME:  
PROJECT  
MANAGER:  
DRAWN BY:  
REVIEWED BY:  
2006 JWA

PROJECT NAME: BC 105  
MOUNTAIN VILLAGE  
COLORADO 81435

SHEET DESCRIPTION:  
ROOF DETAILS

SHEET NUMBER:  
A600

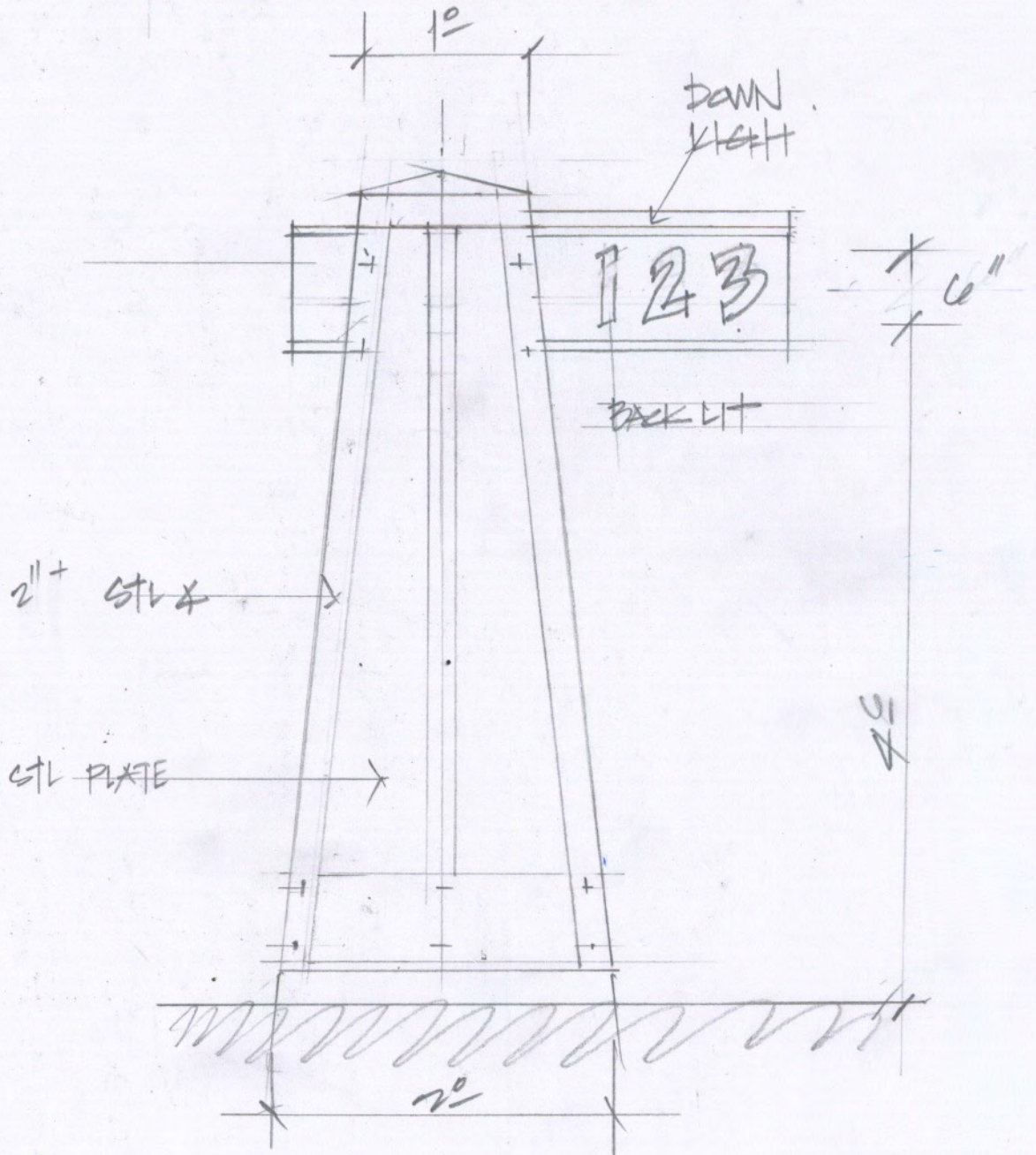
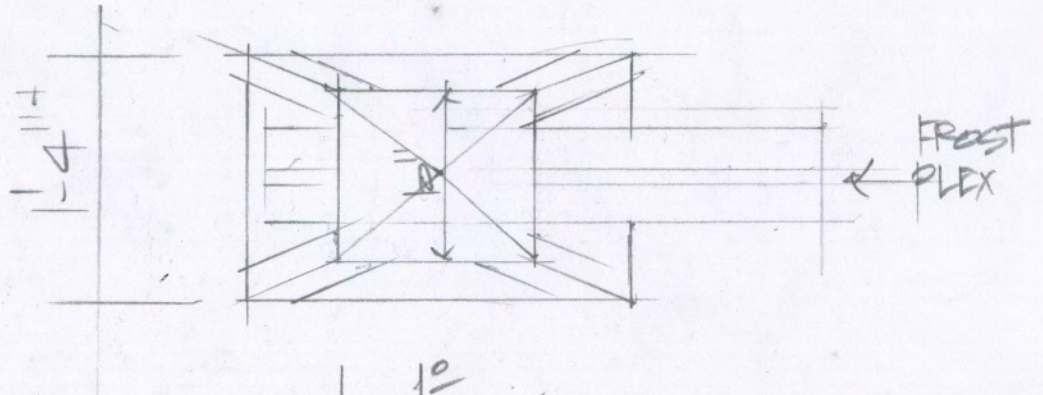



# LOT BC513E, MOUNTAIN VILLAGE, CO MATERIAL SAMPLE PHOTOS



RUSTED STANDING SEAM METAL ROOF



8" VERTICAL BARN WOOD SIDING



OIL RUBBED METAL PANELS



STONE VENEER



BOARD FORM CONCRETE

# SQUARE Exterior Sconces

WS-W38608 / WS-W38610

# MODERN FORMS



**Fixture Type:** \_\_\_\_\_

**Catalog Number:** \_\_\_\_\_

**Project:** \_\_\_\_\_

**Location:** \_\_\_\_\_

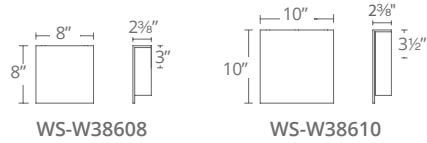

## PRODUCT DESCRIPTION

Four equal sides and a stream of light. Square artfully provides geometry to wall surfaces in the daytime when mounted in multiples while providing safe illumination of pathways and dramatic visual intrigue in the evening. Perfect for wall grazing surfaces.

## SPECIFICATIONS

**Construction:** Aluminum

**Light Source:** High output LED

**Finish:** Black (BK), Bronze (BZ), Titanium (TT)

**Standards:** ETL & cETL Wet Location listed, CEC Title 24 Compliant, ADA Compliant, IP65, Dark Sky friendly

## FEATURES

- Weather-resistant powder coat
- No transformer or driver needed
- Dimmer: ELV
- Rated Life: 50,000 hours
- Color temp: 3000K
- 277V options available
- CRI: 90

## ORDER NUMBER

Model	Width	Wattage	Voltage	LED Lumens	Delivered Lumens	Finish
WS-W38608	8"	11W	120V	391	373	BK <i>Black</i>
WS-W38610	10"	18W		700	630	BZ <i>Bronze</i>
						TT <i>Titanium</i>

Example: WS-W38608-BZ

For 277V special order, add an "F" before the finish: WS-W38608F-BZ

modernforms.com  
Phone (866) 810.6615  
Fax (800) 526.2585

Headquarters/Eastern Distribution Center  
44 Harbor Park Drive  
Port Washington, NY 11050

Central Distribution Center  
1600 Distribution Ct  
Lithia Springs, GA 30122

Western Distribution Center  
1750 Archibald Avenue  
Ontario, CA 91760

# LOUVER BRICK LIGHTS Endurance™

WL-5205

# WAC LIGHTING

Responsible Lighting®

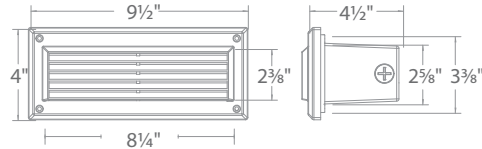

Fixture Type:

E: EXT. STEP LIGHT

Catalog Number:

Project:

Location:

## PRODUCT DESCRIPTION

Die cast aluminum factory sealed housings with patent pending design for a water and dust proofing. IP66 rated outdoor brick light

## FEATURES

- IP66 and ETL & cETL Wet Location Listed
- ADA Compliant
- Factory-Sealed LED Light Engine
- Die-Cast Aluminum Construction (K-Alloy)
- 120V Direct Wire - No Driver Needed
- Glare controlling die casted aluminum louver.

## SPECIFICATIONS

**Construction:** Die-cast aluminum (K-Alloy)

**Power:** Line Voltage input (120V), 50/60Hz

**CRI:** 90

**Dimming:** 100% - 10% with Electronic Low Voltage (ELV) dimmer

**Finish:** Architectural Bronze, Black, Graphite and White

**Standards:** IP66, ADA, ETL & cETL Wet Location Listed

**Rated Life:** 80,000 hours

**Operating Temperature:** -40°C to 50°C (-40°F to 122°F)

## ORDER NUMBER

		Power	Max Delivered Lumens	Color Temp	Finish
<b>WL-5205-30</b>	Louver	5.5W	45	3000K	<b>ABZ</b> Architectural Bronze <b>ABK</b> Architectural Black <b>AGH</b> Architectural Graphite <b>AWT</b> Architectural White

Example: **WL-5205-30-AWT**

WAC Lighting  
www.waclighting.com  
Phone (800) 526.2588 • Fax (800) 526.2585

Headquarters/Eastern Distribution Center  
44 Harbor Park Drive • Port Washington, NY 11050  
Phone (516) 515.5000 • Fax (516) 515.5050

Western Distribution Center  
1750 Archibald Avenue • Ontario, CA 91760  
Phone (800) 526.2588 • Fax (800) 526.2585

GENERAL CIVIL ENGINEERING NOTES:

1. THE EXISTING UTILITY LINES SHOWN ON THE PLANS ARE APPROXIMATE. AT LEAST TWO (2) FULL WORKING DAYS PRIOR TO COMMENCING CONSTRUCTION, THE CONTRACTOR SHALL CONTACT THE UTILITY NOTIFICATION CENTER OF COLORADO @ 1-800-922-1987 OR 811 TO GET ALL UTILITIES LOCATED. IF ANY OF THESE UNDERGROUND UTILITIES ARE IN CONFLICT WITH THE CONSTRUCTION PLANS, THE CONTRACTOR SHALL NOTIFY THE ENGINEER AND WORK WITH THE ENGINEER TO FIND A SOLUTION BEFORE THE START OF CONSTRUCTION.

INSTALLATION AND SEPARATION REQUIREMENTS SHALL BE COORDINATED WITH THE INDIVIDUAL UTILITY PROVIDERS.

THE UTILITY PROVIDERS ARE:  
SEWER, WATER, CABLE TV AND FIBEROPTIC: TOWN OF MOUNTAIN VILLAGE  
NATURAL GAS: BLACK HILLS ENERGY  
POWER: SAN MIGUEL POWER  
TELEPHONE: CENTURY LINK

2. PRIOR TO BEGINNING ANY CONSTRUCTION ACTIVITIES, ALL NECESSARY PERMITS SHALL BE OBTAINED BY THE OWNER OR CONTRACTOR.

3. IT IS THE CONTRACTOR'S RESPONSIBILITY TO INSURE THAT EXCAVATED SLOPES ARE SAFE AND COMPLY WITH OSHA REQUIREMENTS. REFER TO THE SITE-SPECIFIC REPORT FOR THIS PROJECT FOR ADDITIONAL INFORMATION.

4. ALL TRENCHES SHALL BE ADEQUATELY SUPPORTED OR LAID BACK PER OSHA REGULATIONS.

5. ALL MATERIALS AND CONSTRUCTION SHALL BE IN CONFORMANCE WITH THE TOWN OF MOUNTAIN VILLAGE DESIGN STANDARDS LATEST EDITION. ALL CONSTRUCTION WITHIN EXISTING STREET OR ALLEY RIGHT-OF-WAY SHALL BE SUBJECT TO TOWN OF MOUNTAIN VILLAGE INSPECTION.

6. THE CONTRACTOR SHALL HAVE ONE COPY OF THE STAMPED PLANS ON THE JOB SITE AT ALL TIMES.

7. THE CONTRACTOR SHALL NOTIFY THE TOWN 48 HOURS PRIOR TO THE START OF CONSTRUCTION.

8. THE CONTRACTOR IS RESPONSIBLE FOR IMPLEMENTING AND MAINTAINING EROSION AND SEDIMENT CONTROL MEASURES AT ALL TIMES DURING CONSTRUCTION. THE ADJOINING ROADWAYS SHALL BE FREE OF DEBRIS AT THE END OF CONSTRUCTION ACTIVITIES EACH DAY.

9. THE CONTRACTOR SHALL PROVIDE, ERECT AND MAINTAIN PROPER TRAFFIC CONTROL DEVICES UNTIL THE SITE IS OPEN TO TRAFFIC. ANY TRAFFIC CLOSURES MUST BE COORDINATED WITH THE TOWN OF MOUNTAIN VILLAGE.

10. ALL DAMAGE TO PUBLIC STREETS AND ROADS, INCLUDING HAUL ROUTES, TRAILS, OR STREET IMPROVEMENTS, OR TO PRIVATE PROPERTY, SHALL BE REPAIRED AT THE SOLE EXPENSE OF THE CONTRACTOR TO THE ORIGINAL CONDITIONS.

11. WHEN AN EXISTING ASPHALT STREET IS CUT, THE STREET MUST BE RESTORED TO A CONDITION EQUAL TO OR BETTER THAN ITS ORIGINAL CONDITION. THE FINISHED PATCH SHALL BLEND SMOOTHLY INTO THE EXISTING SURFACE. ALL LARGE PATCHES SHALL BE PAVED WITH AN ASPHALT LAY-DOWN MACHINE.

12. IF DEWATERING IS REQUIRED, THE CONTRACTOR SHALL NOTIFY THE ENGINEER. ANY DISCHARGE REQUIREMENTS SHALL BE COORDINATED WITH THE TOWN OF MOUNTAIN VILLAGE.

13. CONTRACTOR SHALL NOTIFY ALL RESIDENTS IN WRITING 24 HOURS PRIOR TO ANY SHUT-OFF IN SERVICE. THE NOTICES MUST HAVE CONTRACTOR'S PHONE NUMBER AND NAME OF CONTACT PERSON, AND EMERGENCY PHONE NUMBER FOR AFTER HOURS CALLS. ALL SHUT-OFF'S MUST BE APPROVED BY THE TOWN AND TOWN VALVES AND APPURTENANCES SHALL BE OPERATED BY TOWN PERSONNEL.

14. CONTRACTOR SHALL KEEP SITE CLEAN AND LITTER FREE (INCLUDING CIGARETTE BUTTS) BY PROVIDING A CONSTRUCTION DEBRIS TRASH CONTAINER AND A BEAR-PROOF POLY-CART TRASH CONTAINER, WHICH IS TO BE LOCKED AT ALL TIMES.

15. CONTRACTOR MUST BE AWARE OF ALL TREES TO REMAIN PER THE DESIGN AND APPROVAL PROCESS AND PROTECT THEM ACCORDINGLY.

16. THE CONTRACTOR SHALL PROVIDE UNDERGROUND UTILITY AS-BUILTS TO THE TOWN.

17. ALL STRUCTURAL FILL UNDER HARDSCAPE OR ROADS MUST BE COMPACTED TO 95% MODIFIED PROCTOR (MIN.) AT PLUS OR MINUS 2% OF THE OPTIMUM MOISTURE CONTENT. NON-STRUCTURAL FILL SHALL BE PLACED AT 90% (MIN.) MODIFIED PROCTOR.

18. UNSUITABLE MATERIAL SHALL BE REMOVED AS REQUIRED BY THE SOILS ENGINEER. ALL MATERIALS SUCH AS LUMBER, LOGS, BRUSH, TOPSOIL OR ORGANIC MATERIALS OR RUBBISH SHALL BE REMOVED FROM ALL AREAS TO RECEIVE COMPACTED FILL.

19. NO MATERIAL SHALL BE COMPACTED WHEN FROZEN.

20. NATIVE TOPSOIL SHALL BE STOCKPILED TO THE EXTENT FEASIBLE ON THE SITE FOR USE ON AREAS TO BE REVEGETATED.

21. THE CONTRACTOR SHALL BE RESPONSIBLE FOR DUST ABATEMENT AND EROSION CONTROL MEASURES DEEMED NECESSARY BY THE TOWN, IF CONDITIONS WARRANT THEM.

22. ALL DISTURBED GROUND SHALL BE RE-SEEDED WITH A TOWN-APPROVED SEED MIX. REFER TO THE LANDSCAPE PLAN.

23. THE CONTRACTOR IS REQUIRED TO PROTECT ALL EXISTING SURVEY MONUMENTS AND PROPERTY CORNERS DURING GRADING AND CONSTRUCTION.

24. ALL UNDERGROUND PIPE SHALL BE PROTECTED WITH BEDDING TO PROTECT THE PIPE FROM BEING DAMAGED.

25. HOT TUBS SHALL DRAIN TO THE SANITARY SEWER (OR PUMPED TO AA CLEAN-OUT).

26. THE UTILITY PLAN DEPICTS FINAL UTILITY LOCATIONS BUT HAS BEEN COMPLETED AT A PRELIMINARY STAGE. CONTRACTOR SHALL VERIFY ALIGNMENTS WITH THE ARCHITECT PRIOR TO CONSTRUCTION.

**ACO DRAIN**  
**KlassikDrain - K100 Galvanized steel edge rail channel system**

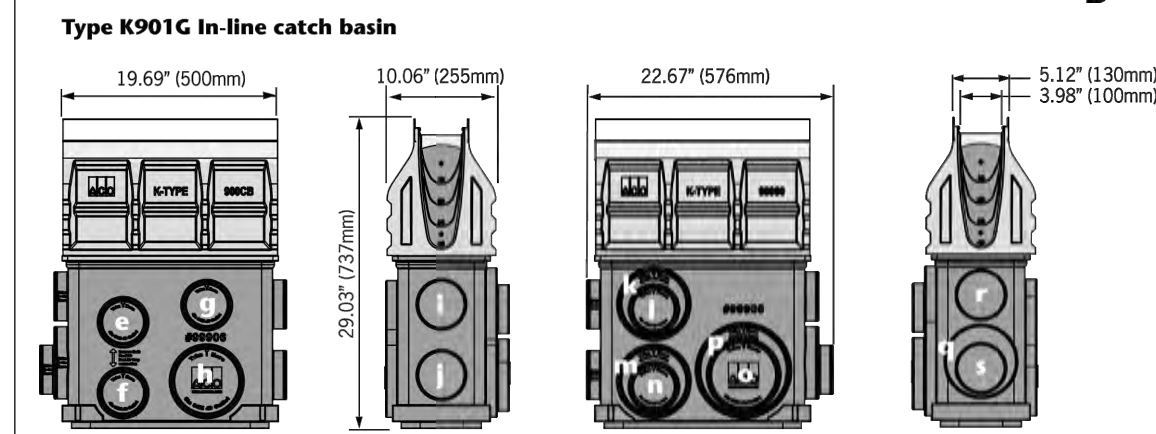
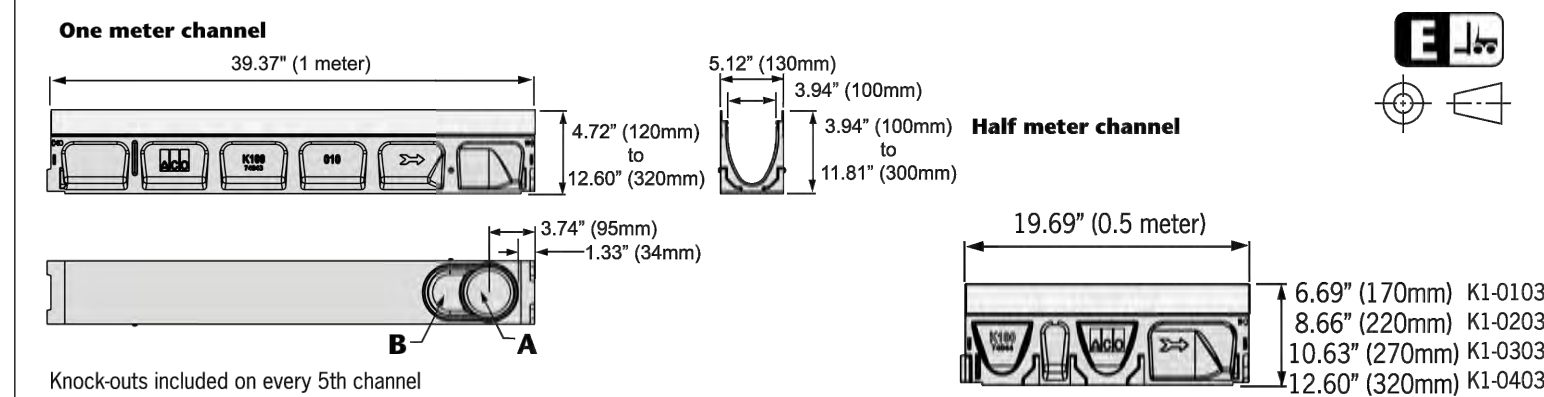

**Outlet flow rates**

Outlet	Product	Outlet size (Sch. 40)	Invert Depth	GPM	CFS	End Cap
a	Bottom outlet - K00	4" round	3.94"	108	0.24	
a	Bottom outlet - K40	4" round	11.81"	187	0.42	
b	Bottom outlet - K00	6" oval	3.94"	177	0.39	
b	Bottom outlet - K40	6" oval	11.81"	306	0.68	
c	End outlet - K20	4" round	7.87"	132	0.29	
c	End outlet - K40	4" round	11.81"	171	0.38	
d	K1-308/6 6" outlet cap	6" oval	9.84"	233	0.52	
e	K1-408/6 6" outlet cap	6" oval	11.81"	264	0.59	
f	Type K1-901G	4" round	19.30"	226	0.50	
g	Type K1-901G	4" round	26.67"	265	0.59	
h	Type K1-901G	4" round	25.30"	263	0.59	
i	Type K1-901G	4" round	18.56"	222	0.49	
j	Type K1-901G	6" round	29.85"	586	1.30	
k	Type K1-901G	4" round	26.43"	269	0.60	
l	Type K1-901G	4" round	19.36"	227	0.51	
m	Type K1-901G	6" round	27.30"	644	1.35	
n	Type K1-901G	6" round	19.99"	505	1.12	
o	Type K1-901G	6" round	26.43"	593	1.32	
p	Type K1-901G	8" round	27.30"	1051	2.34	
q	Type K1-901G	4" round	27.17"	273	0.61	
r	Type K1-901G	4" round	20.68"	235	0.52	
s	Type K1-901G	4" round	18.99"	224	0.50	
t	Type K1-901G	6" round	27.17"	602	1.34	

Note: These are the pipe flow rates at the specified outlet, NOT channel flow rates. Catch basin flow rates are without trash bucket - using trash bucket reduces flow.

April 2018

www.ACOdrain.us



ACO Specification Information

**ACO DRAIN**  
**Type 478Q Longitudinal ductile iron grate (ADA)**

**Product Features**

- Certified to EN 1433 Load Class E - 135,000 lbs - 2,788 psi
- Uses 'QuickLok' boltless locking system
- Suitable for use with K100, KS100, H100-8, H100-10, H100K-8, H100KS-8, and NW100 channels
- Manufactured from ductile iron to ASTM A 536-84 - Grade 65-45-12
- E-coated for improved resistance against rust
- Complies with ADA - American Disabilities Act of 1990 Section 4.5.4
- Bicycle Tire Penetration Resistant to AS 3996 - 2006



**Specifications**

**General**  
The surface drainage system shall be ACO Drain K100, KS100, H100-8, H100-10, H100K-8, H100KS-8, and NW100 channels\* complete with ACO Type 478Q longitudinal ductile iron grate with 'QuickLok' locking as manufactured by ACO, Inc. or similar approved.

**Materials**  
The covers shall be manufactured from ductile iron and have minimum properties as follows:

- Independently certified to meet Load Class E to EN 1433 - 135,000 lbs - 2,788 psi
- Ductile iron to ASTM A 536-84 - Grade 65-45-12
- Intake area of 22.5 sq. in. (145.16 cm<sup>2</sup>) per half meter of grate

The overall width of 4.85" (123mm) and overall length of 19.69" (500mm). Slots measure at a maximum of 0.28" (7mm).

**Installation**  
The trench drain system and grates shall be installed in accordance with the manufacturer's installation instructions and recommendations.

April 2018

www.ACOdrain.us



ACO Specification Information

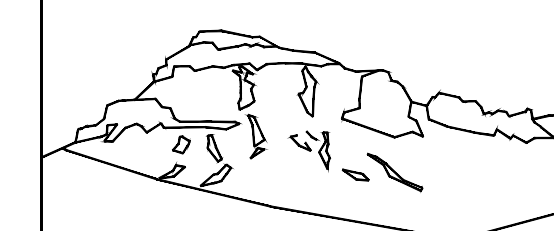

Uncompahgre Engineering, LLC

P.O. Box 3945  
Telluride, CO 81435  
970-729-0683

**SUBMISSIONS:**  
SUBMITTAL 2020-10-13

Lot BC513E  
Lawson Overlook  
Mtn. Village, CO

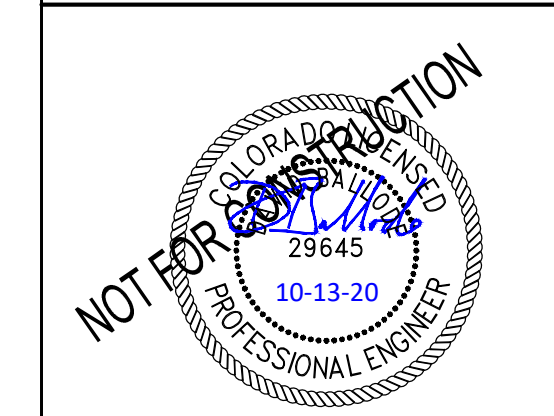

CONTRACTOR TO REVIEW AND COMPARE ALL CHAPTERS AND INTERDISCIPLINARY DRAWINGS AND REPORT ANY DISCREPANCIES TO THE ARCHITECT PRIOR TO ANY FIELD WORK BEING DONE IN ACCORDANCE WITH AIA DOCUMENT A201

Notes

C1

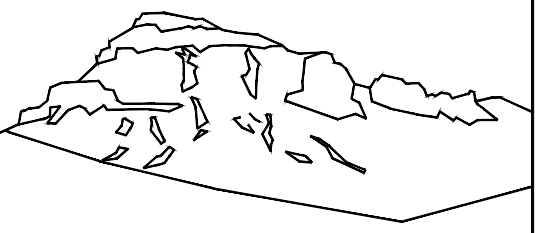

Uncompahgre Engineering, LLC

P.O. Box 3945  
Telluride, CO 81435  
970-729-0683

SUBMISSIONS:  
SUBMITTAL 2020-10-13

Lot BC513E  
Lawson Overlook  
Mtn. Village, CO



CONTRACTOR TO REVIEW AND COMPARE ALL CHAPTERS AND INTERDISCIPLINARY DRAWINGS AND REPORT ANY DISCREPANCIES TO THE ARCHITECT PRIOR TO ANY FIELD WORK BEING DONE IN ACCORDANCE WITH AIA DOCUMENT A201

Grading Plan  
and  
Driveway Profile

C2.1

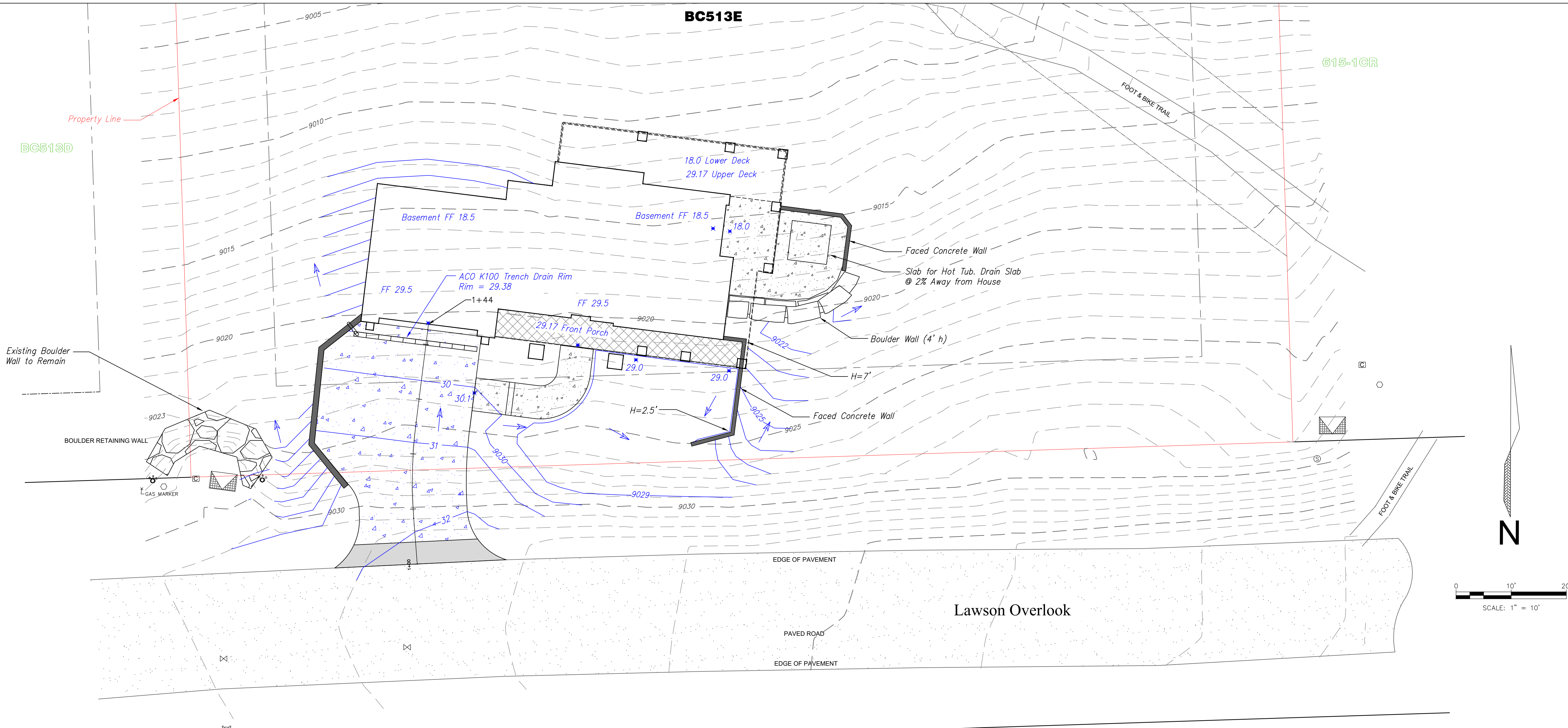

### Driveway Profile

HIGH PT STA: 1+12.88  
HIGH PT ELEV: 9031.66  
GRADE BREAK STA = 1+00.15  
PVI STA: 1+16.91  
PVI ELEV: 9032.298  
K: 2.01  
LVC: 8.07  
BVCS: 1+12.88  
BVCE: 9031.66  
EVCS: 1+20.95  
EVCE: 9031.10

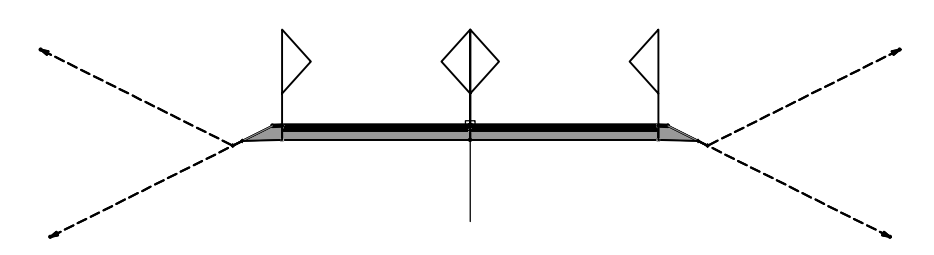
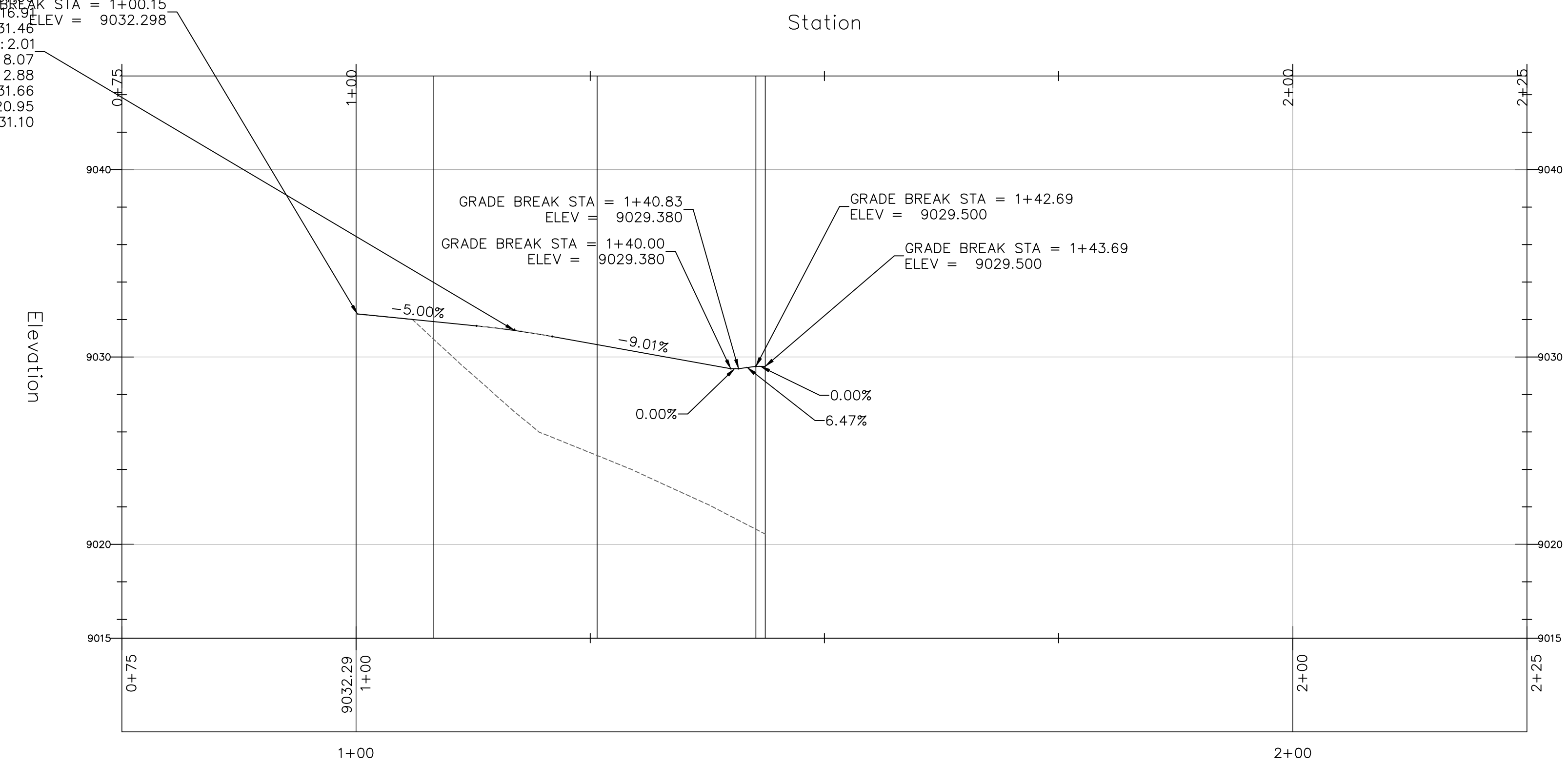

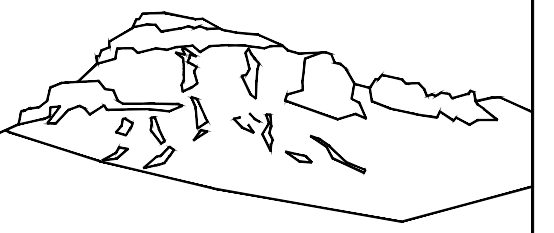

Uncompahgre  
Engineering, LLC

P.O. Box 3945  
Telluride, CO 81435  
970-729-0683

**SUBMISSIONS:**  
SUBMITTAL 2020-10-13

Lot BC513E  
Lawson Overlook  
Mtn. Village, CO



CONTRACTOR TO REVIEW AND COMPARE ALL  
CHAPTERS AND INTERDISCIPLINARY DRAWINGS  
AND REPORT ANY DISCREPANCIES TO THE  
ARCHITECT PRIOR TO ANY FIELD WORK BEING  
DONE IN ACCORDANCE WITH AIA DOCUMENT A201

Utilities

C3

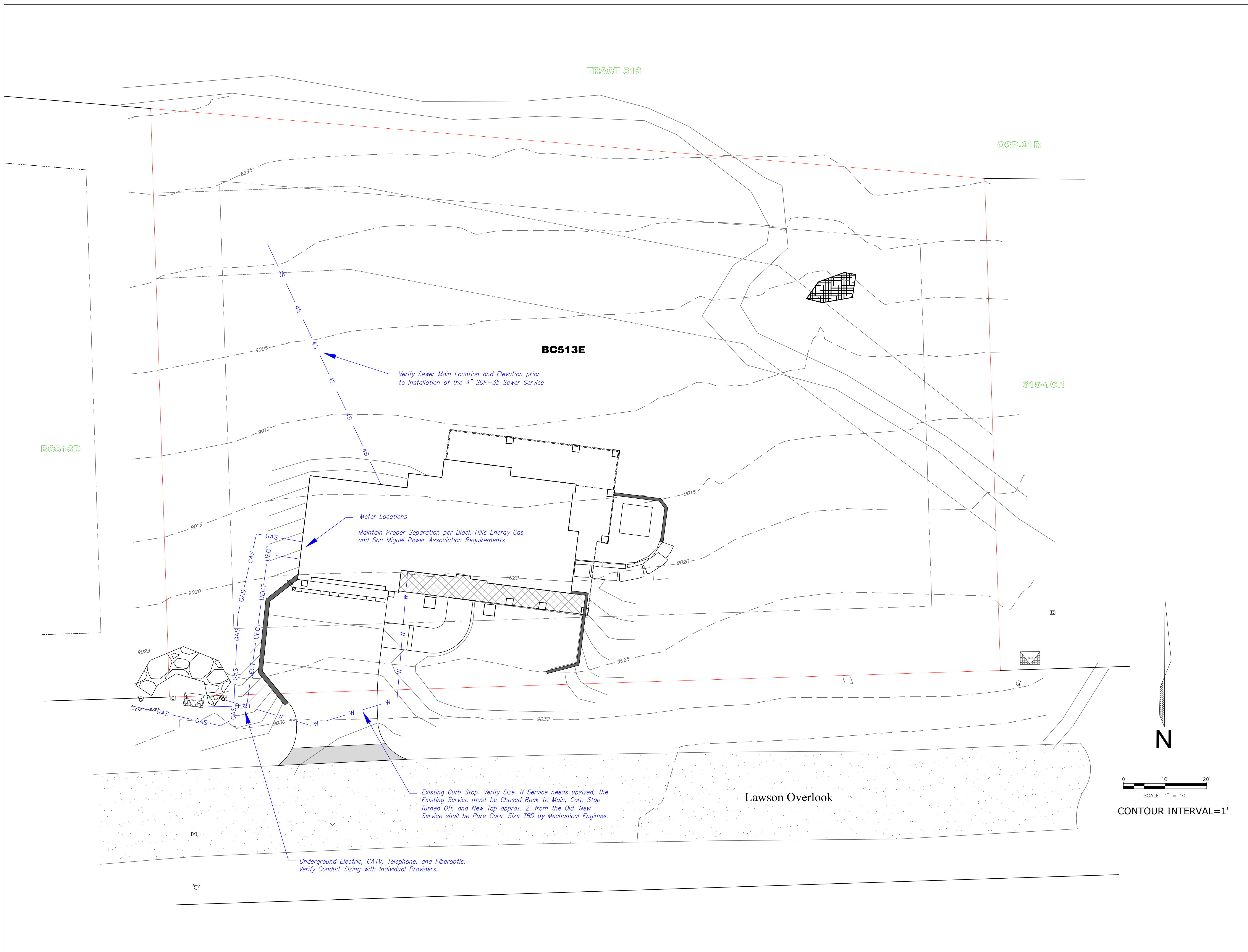



**TO:** Mountain Village Design Review Board

**FROM:** John Miller, Senior Planner

**FOR:** Design Review Board Public Hearing; February 4, 2021

**DATE:** January 22, 2021

**RE:** Initial Architecture and Site Review for a new Single-Family detached condominium on Lot 165, Unit 6, 160 Cortina Drive, pursuant to CDC section 17.4.11. Concurrent review and recommendation to Town Council regarding a variance request for Building Height and Average Building Height pursuant to CDC section 17.4.16.

### APPLICATION OVERVIEW:

#### **PROJECT GEOGRAPHY**

**Legal Description:** UNIT 6 CORTINA LAND CONDOMINIUMS ACC TO THE MAP OF THE CORTINA LAND CONDOMINIUMS A COLORADO COMMON INTEREST COMMUNITY LOT 165 TOWN OF MOUNTAIN VILLAGE REC NOV 30 2004 PL 1 PG 3400 THRU 3401 AND ALSO ACC TO THE DECLARATION REC NOV 30 2004 AT REC NO 370697

**Address:** 160 Cortina Drive  
**Applicant/Agent:** Jamie Daugaard, Centre Sky Architecture  
**Owner:** Silver Glade Development Company  
**Zoning:** Multi-Family  
**Existing Use:** Vacant  
**Proposed Use:** Multi-Family  
**Lot Size:** 0.27 Acres

#### **Adjacent Land Uses:**

- **North:** Multi-Family
- **South:** Multi-Family
- **East:** Multi-Family
- **West:** Multi-Family

#### **ATTACHMENTS**

- Exhibit A: Application
- Exhibit B: Plan Set

*Figure 1: Vicinity Map*



**Case Summary:** Jamie Daugaard of Centre Sky Architecture (Applicant), working on behalf of the Silver Glade Development Company (Owner), is requesting the Design Review Board (DRB) approval of an Initial Architectural and Site Review (IASR) Application for a new single-family detached condominium at Lot 165, Unit 6 – 160 Cortina Drive. In addition to the Design Review, the DRB is providing a concurrent review and recommendation to the Town Council regarding a requested Variance to the CDC provisions for building height. The Lot is approximately 0.27 acres and is zoned Multi-Family (Detached Condominium) with the overall square footage of the home being approximately 7,651 gross square feet. The applicant has provided all the required materials for the IASR for the proposed home.

**History and Existing Conditions:** Lot 165-6 is located within the Cortina Land Condominiums (Cortina) along San Joaquin Road between the existing Cassidy Ridge and Winterleaf developments. When approved, a total of 22 Condominium Units and 3 Parcels (A, B, and C) originally designated as a General Common Element of the land condos were approved by the Town. Subsequent to the creation of the common interest community, Units 18 and 19 were replatted into Unit 18R to allow for the development of a Multi-family project on Units 17R, 18R, 20, and Parcel A (later identified as Unit 23). The remainder of the Lots within Cortina are designated for single-family detached homes. A large number of the Units within Cortina face topographical issues such as steep forested slopes with difficult access.

Unit 6 is entirely forested with approximately 95% of the unit over 30% slope. Units 5 and 6 were originally accessed by a driveway easement established when Cortina was created. This easement was later modified and expanded to allow additional access for Units 7 and 8. Additionally, it appears there may be design variations proposed and discussed below in which the DRB should provide comments related to their appropriateness.

**Applicable CDC Requirement Analysis:** The applicable requirements cited may not be exhaustive or all-inclusive. The applicant is required to follow all requirements even if an applicable section of the CDC is not cited. ***Please note that Staff comments will be indicated by Italicized Text.***

Table 1

<b>CDC Provision</b>	<b>Requirement</b>	<b>Proposed</b>
<b>Maximum Building Height</b>	35' (shed)	55'-4"***
<b>Maximum Avg. Building Height</b>	30' (shed)	32'-10"***
<b>Maximum Lot Coverage</b>	40% Maximum	39%
<b>General Easement Setbacks</b>	16 Foot Setback (No GE)	
<b>Roof Pitch</b>		
Primary		1:12
Secondary		Flat
<b>Exterior Material**</b>		
Stone	35% minimum	35.4%
Windows/Doors	40% maximum	31.4%
<b>Parking</b>	1 enclosed / 1 exterior	1/1

**Design Review Board Design Variation Requests:**

**1. Parking Requirements – Section 17.5.8(C)**

**\*\*These items will require Town Council approval of a Variance**



## **Chapter 17.3: ZONING AND LAND USE REGULATIONS**

### **17.3.12: Building Height Limits**

Sections 17.3.11 and 17.3.12 of the CDC provide the methods for measuring Building Height and Average Building Height, along with providing the height allowances for specific types of buildings based on their architectural form. The proposed design incorporates shed roof forms limited to 35 feet. The maximum average height must be at or below 30 feet for shed roof forms. The average height is an average of measurements from a point halfway between the roof ridge and eave. The points are generally every 20 feet around the roof. The maximum height is measured from the highest point on a roof directly down to the existing grade or finished grade, whichever is more restrictive.

*Staff: Based on the heights provided as part of the submittal documents, the maximum building height is 55'-4" (+20'-4") from the highest ridge to the grade below and the maximum average building height is shown at 32'-10" (+2'-10"). As part of the height analysis and variance request, the applicant has provided a parallel plane graphic demonstrating the portions of the home penetrating the 35-foot parallel slope height allowance for shed roof forms. Because the heights exceed the CDC requirements, the applicant will be required to obtain Town Council approval of a variance to allow for these requests. The DRB generally weighed in on this request during a December Work Session in which they suggested that although the variance request seems reasonable in theory due to the topography of the site, the overall height request of 20+ feet was excessive. The DRB provided guidance to reduce the overall height of the home in order to better align the design with existing homes in Cortina. Based on the attached plan set, it appears that the design was reduced by 1 foot from the work session for a total of 55'-4" rather than 56'-4". Staff will discuss this request in more detail below under the provisions related to Variances. If the DRB determines the height appropriate, then there shall be a condition of approval which shall require a survey prior to framing inspections in order to demonstrate compliance with maximum heights.*

### **17.3.14: General Easement Setbacks**

Lot 165 Unit 6 is burdened by a sixteen (16) foot setback that surrounds its building envelope. The CDC provides that the GE and other setbacks be maintained in a natural, undisturbed state to provide buffering to surrounding land uses. The CDC does provide for some development activity within the GE and setbacks such as Ski Access, Utilities, Address Monuments, and Fire Mitigation. At the December work session, the DRB suggested that the applicant attempt to remove structural elements from the setback, and it appears that they have largely accomplished this based on the attached site plan.

*Staff: The proposal includes several setback encroachments that fall into the above category of permitted setback development activity including the following:*

- *Driveway: The area of the front setback serves not only as the driveway for unit 6 but also for units 7 and 8. This area has been legally encumbered and is limited in its overall use.*
- *Utilities: Utilities will be required to cross the setback areas due to existing locations of Sewer, Water, and Shallow Utilities as shown on the Utility Plan.*

*The proposal also includes GE encroachments that do not fall into the above category of permitted GE development activity:*

- *Landscaping: Due to the steepness of the lot, the applicant has proposed a rip-rap lined swale to capture stormwater between Units 5 and 6. This landscaping should be minimal in nature. In addition, the applicant has proposed minor grading and landscaping to occur between the setback of Units 6 and 7. The DRB will need to weigh in on the appropriateness of these requests. As shown, the grading between Units 6 and 7 appears to affect both Lots and it may be helpful to show only how the grading relates to Unit 6 independently.*

*It should be noted that regardless of the encroachment, the DRB can waive the GE setback or other setbacks and allow for prohibited activities if it is determined that the applicant has demonstrated hardship and mitigated off-site impacts.*

*Any foundation walls that are within 5' of setback will require a footer survey prior to pouring concrete to ensure there is no additional encroachments into the setback area.*

## **Chapter 17.5: DESIGN REGULATIONS**

### **17.5.4: Town Design Theme**

The Town of Mountain Village has established design themes aimed at creating a strong image and sense of place for the community. Due to the fragile high alpine environment, architecture and landscaping shall be respectful and responsive to the tradition of alpine design – reflecting elements of alpine regions while blending influences that visually tie the town to mountain buildings. The town recognizes that architecture will continue to evolve and create a regionally unique mountain vernacular, but these evolutions must continue to embrace nature and traditional style in a way that respects the design context of the neighborhoods surrounding the site.

*Staff: The CDC provides design theme characteristics that attempt to link existing and new architecture throughout the Mountain Village. The home can be categorized as a contemporary mountain modern design that incorporates the traditional materials used throughout the Mountain Village vernacular. The design features several roof types such as shed and flat roofs proposed for the garage. The applicant appears to address compliance with these provisions through the building's location, tree preservation, building materials, and overall form. The proposed massing of the structure and exterior materials largely reflect the contemporary rustic designs recently seen within the Town, incorporating a mix of contemporary shed roof forms, horizontal stone elements grounding the structure and exterior horizontal wood that complements the overall lineal design of the home. The materials as proposed are rustic in style, intentionally designed to balance the modern shapes of the structure with the traditional mountain architectural elements of exterior wood, metal, and stone. It appears based on the applicant's submittal that the material palette for the project blends well with both the surrounding community, as well as the overall modern mountain vernacular.*

### 17.5.5: Building Siting Design

The CDC requires that any proposed development blend into the existing landforms and vegetation.

*Staff: Lot 165, Unit 6 is a 0.27-acre lot that slopes drastically from a high point along Cortina Drive down to the shared property line with Cassidy Ridge Condominiums. As shown in the attached survey work, approximately 95% of the site consists of slopes greater than 30%, and in order to develop the site, it appears impossible to not disturb these areas. With that, any development on this site would be difficult to blend into the existing landforms – a problem that staff feels is exacerbated by the requested building height variance and a large amount of fenestration on the north side of the home. For example, the image below provided by the applicant demonstrates an approximation of how the home would appear from San Joaquin Road. Notice the Multifamily development to the right of the image (Cassidy Ridge), and the proposed home within the trees to the left. Although not exact, for the purpose of this discussion staff has inserted two arrows that are the same size into the photo in order to demonstrate the apparent mass of the home as it compares to a large multi-family structure. From this vantage, both structures appear to have similar massing. Generally, the CDC aims for single-family homes to have the massing of other similar single-family homes – which is the nexus of our building height and massing standards.*



### 17.5.6: Building Design

*Staff: The CDC requires that building form and exterior wall forms portray a mass that is thick and strong with a heavy grounded foundation. In order to accomplish this, the applicant is proposing a horizontal rectangular cut deep creek 1 ½ Stone Veneer surrounding the foundation of the home. Additionally, the design calls for horizontal wood siding which appears to limit the feeling of the home projecting upwards given the overall height of the home.*

*A prominent feature of the home is the cantilevered portion of the living space located along the eastern and northern façade. The DRB discussed this cantilevered design at the December Work Session and was not unanimous in determining that this portion of the home was sufficiently grounded. Generally, it seems that the use of the columns appear to make these piers seem much more*

*grounded than they otherwise would in the absence of the stone base.*

*The home's exterior palette as shown in the materials sheet of the submission appears to blend well, providing some contrast between the stone, metal, and wood. The garage door is called out as being faced with metal panels shown within the material list. The CDC*

allows for black and grey standing seam roofing materials and this appears to meet that requirement.

The applicant's plans have references to snowmelt, but specific areas have not been delineated. It is anticipated that this home will have exterior snowmelt and prior to the final review, the applicant shall revise these plans to detail areas of exterior snowmelt and the associated square footages.

#### **17.5.7: Grading and Drainage Design**

Staff: The applicant has provided a conceptual grading and drainage plan provided by Alpine Land Consulting, LLC. The proposal provides positive drainage for the residence as well as delineating disturbed areas including the driveway and areas surrounding the home. As required by the CDC, all disturbed areas are to have final grades of 2:1 or less, and these criteria appear to be met. As noted above, grading has been proposed within the setbacks between Units 6-7 and it would be preferable to understand how the development of Unit 6 and the associated grading is accomplished absent or independent of any grading on the undeveloped Unit 7.

#### **17.5.8: Parking Regulations**

Staff: The CDC requires all detached condominium developments to provide two parking spaces. The applicant has shown a total of 3 spaces but the following items should be noted.

1. The interior spaces shown do not appear to meet the dimensional requirements of 9'x18'. For that reason, in this memo staff has only counted 1 interior space towards the parking requirement. If it's determined that two spaces meeting the size requirement above can fit inside the garage, then the plan should be updated to reflect such.
2. Due to the location of the driveway easement for Units 7-8 and the positioning of the home, there is only room for one parallel exterior space. Although allowed by the CDC with approval by the DRB as tandem parking – there could be additional concerns related to turning any parked vehicles around to exit the drive.

There are additional design standards for parking within the CDC that are not being met as part of this proposal including the following (Section 17.5.8(C)):

- Garage Back Out requirements
- Access to Parking Spaces - Each required parking space shall have unobstructed access from a road or alley or from an aisle or drive connecting with a road or alley without requiring the movement of another vehicle unless the review authority approves tandem parking.

The DRB must determine this request appropriate and must grant a specific approval of the items listed above.

#### **17.5.9: Landscaping Regulations**

The applicant has provided not provided a landscaping plan at this time but will be required to provide this information prior to final review. As such, this plan shall address the Forestry provisions of the CDC concerning Wildfire Mitigation Zones and how the landscaping relates to the approved planting species types listed for Zone 1.

#### **17.5.11: Utilities**

*Staff: All utilities are currently located within proximity to the home. The applicant shall work with the Public Works Director before the final review to verify the specific locations of the connections for the home. The plan set shows the proposed connections and the locations of the proposed utilities based on field research.*

#### **17.5.12: Lighting Regulations**

*Staff: The applicant has not provided a lighting plan at this time but will be required to do so prior to submittal for final review. This shall include locations, cut-sheets, and photometric studies of the exterior fixtures.*

#### **17.5.13: Sign Regulations**

*Staff: The applicant has indicated that the home will be addressed at a shared freestanding monument located at the beginning of the driveway as well as numbering located on the retaining wall of the home. The address numbering as shown in the plan set does not appear to be downlit, and more details should be provided surrounding the illumination of both the freestanding monument and the numbering on the retaining wall prior to final submittal.*

### **Chapter 17.6: SUPPLEMENTARY REGULATIONS**

#### **17.6.1: Environmental Regulations**

*Staff: Fire Mitigation and Forestry Management: Due to the size, steepness, and overall visibility of the lot, staff is requesting that the fire mitigation requirement be waived except for proposed landscaping to be located in Zone 1.*

*Steep Slopes: Due to the unique location and topography of the site, staff believes that the applicant has worked to provide logical siting for the residence. Due to the extent of slopes over 30%, the design of the house at the top of the property is logical. The grading plan minimizes disturbance to steep slope areas by retaining walls. A Colorado PE has designed the civil plans for the development of the Site.*

#### **17.6.6: Roads and Driveway Standards**

*Staff: Because of the location of the home and the nature of the shared drive for Units 6, 7, and 8 - there is effectively no driveway for Unit 6 other than the designated tandem exterior parking area directly outside of the garage. It would be helpful for the DRB to better understand the access easement and/or shared driveway and the applicant should provide a grade analysis from the point on Cortina Drive to Unit 6 in order to determine if there are any additional concerns as it relates to the Road and Driveway Standards.*

#### **17.6.8: Solid Fuel Burning Device Regulations**

*Staff: The applicant has indicated that the proposed home does include fireplaces and these are gas burning fixtures as required.*

### **Chapter 17.7: BUILDING REGULATIONS**

#### **17.7.19: Construction Mitigation**

*Staff: The applicant has not submitted a Construction Mitigation Plan as part of the IASR. Although not required for initial, there are a number of staff concerns at the site as it relates to construction mitigation for Unit 6, but more importantly the adjacent properties and homes. It should be noted that due to the unique location of the site, the applicant will need to develop access to the site prior to constructing the residence. As part of this, parking on site will be limited during the initial phase of the project. The contractor will be instructed to fence the site and any soil and or trees not to be removed will need to be*

protected throughout the project. Staff does have some concerns related to staging and offsite parking impacts, and it may be helpful to discuss additional mitigation steps such as neighborhood updates on the project as it transitions from design to construction.

**Variance Request:**

*For the reasons listed above, the applicant has requested a Variance to both the Maximum Building Height requirements and the Average Building Height requirements. As proposed within the provided plans, the applicant is requesting a 20'-4" variance to the Maximum Building Height, and a 2'-10" variance to the Maximum Average Building Height. While staff does believe a variance request for Unit 6 may be appropriate, there are concerns that a 20+ foot variance is an excessive request. For example, the most recent approved variance for a SFCI home was approximately 8 feet, and the board has never reviewed a request of this magnitude in the past.*

*The current design of the home cannot be accomplished without this request being ultimately recommended by DRB and approved by Town Council. The CDC provides criteria for approval of a Variance within the CDC which has been addressed and provided by the applicant as part of this packet. The DRB will need to determine if they agree that these criteria have been met in their entirety in order to recommend approval of a variance to the Town Council.*

**Chapter 17.4: DEVELOPMENT REVIEW PROCEDURES**

**17.5.16: Variance Procedure:**

*Staff has evaluated the following standards (1-8) as the criteria that must be met for Town Council to approve the variance:*

1. *The strict application of the CDC regulations would result in exceptional and undue hardship upon the property owner in the development of property lot because of special circumstances applicable to the lot such as size, shape, topography, or other extraordinary or exceptional physical conditions;*

*Staff: Lot 165 Unit 6 is burdened by a number of constraints including size and steepness of the site. The lot is relatively small at 0.27 acres and the majority of the site (95%) is steeply sloped in excess of 30%. In addition to the size and steepness, the lot is limited by its building envelope and the existing driveway easement referenced above. With that, it's unclear to staff if the granting of this allowance would result in an exceptional or undue hardship on the property owner as it relates to the development of this Lot. This Lot could still be developed absent this variance approval, although it would require a substantial re-design of the project. Alternatively, the applicant could propose a modest variance request in order to better align with the existing development pattern of Cortina Drive.*

2. *The variance can be granted without substantial detriment to the public health, safety, and welfare;*

*Staff: The variance as proposed could potentially impact public welfare through increased viewshed impacts relating to the massing of the home on the north elevation as seen from San Joaquin and adjacent properties. The variance request is large as it relates to previously approved variance requests in the Mountain Village and could set precedent for future building height variance requests for the undeveloped Cortina lots and elsewhere. The DRB must determine if this impact is in fact a substantial detriment.*

3. *The variance can be granted without substantial impairment of the intent of the CDC;*

*Staff: The intent of the CDC is to allow for guided uniform development based on standards applicable to each zoning designation. Although the topography of the site has created a unique circumstance for the owner, staff does not believe that the intent of the Variance procedures is to allow for a single-family home to have the massing of a multi-family structure. It will be important for the DRB and Town Council to determine if this request is meeting the intent of the CDC as it relates to building heights, and more importantly the appropriateness of variance.*

4. *Granting the variance does not constitute a grant of special privilege in excess of that enjoyed by other property owners in the same zoning district, such as without limitation, allowing for a larger home size or building height than those found in the same zone district;*

*Staff: At the December work session, the DRB requested more information relating to existing homes in Cortina. Staff has provided certain information for Units 11, 12, 13, 14, and 22 below as they relate to Unit 6.*

<i>Unit #</i>	<i>Lot Size</i>	<i>Square Footage</i>	<i>Max Height</i>
6	0.27 ac	7,651	55'-4"
11	0.21 ac	4,972	37'-9"
12	0.21 ac	6,546	34'-8.5"
13	0.21 ac	3,858	34'-6"
14	0.26 ac	7,197	39'-11"
22	0.44 ac	4,020	40'-8.5"

*Based on the above table, there appears to be a large differential in home square footage as well as overall height allowances, with Unit 6 being the largest size and height. In this case, staff believes that the home could be redesigned with a much smaller variance request that would allow for the design to be more in alignment with other property owners and developments within the Cortina Neighborhood.*

5. *Reasonable use of the property is not otherwise available without granting of a variance, and the variance being granted is the minimum necessary to allow for reasonable use;*

*Staff: Staff does not believe that the owner's reasonable use of the property would be limited without the approval of this variance. At the December work session, it was indicated that the DRB was generally comfortable with a variance due to the constraints of the site, but could not support at 20'-4" variance to the maximum building height standards. Based on this, it does not appear that this request is the minimum necessary to allow for the reasonable use of the property.*

6. *The lot for which the variance is being granted was not created in violation of Town regulations or Colorado State Statutes in effect at the time the lot was created;*

*Staff: The lot is within a legally created subdivision.*

7. *The variance is not solely based on economic hardship alone; and*

*Staff: The variance is being requested by the applicant due to topographical and geographical constraints of Lot 165, Unit 6.*

8. *The proposed variance meets all applicable Town regulations and standards unless a variance is sought for such regulations or standards.*

*Staff: The applicant has presented the reasoning as to why the maximum and average building height variance is required based on the unique site-specific constraints of the lot. Staff believes that this request meets all other applicable Town Regulations and Standards.*

---

**Staff Recommendation:** The architectural design of this project is directly tied to the variance request and its approval by Town Council. In this instance, the DRB is providing a recommendation to the Town Council on the appropriateness of the variance request. If the DRB cannot determine that Criteria 1-8 listed above have been met, then staff recommends denial of the IASR application.

If the DRB finds it preferable to continue this item until the Town Council rules on the Variance, that is also a potential option for this body – recognizing that the design is tied to the variance and any Town Council future ruling may require the applicant re-submit for IASR. If that is the preferred path, staff recommends continuing the IASR and voting on the Variance request.

#### **PROPOSED MOTION**

***Staff Note: It should be noted that reasons for approval or rejection should be stated in the findings of fact and motion.***

“I move to recommend denial of the resolution approving a variance to increase the maximum building height to approximately 55 feet and four inches (55’-4”) and the Average Maximum Building Height to 32 feet 2 inches (32’-2”) for Lot 165, Unit 6, based on the evidence provided within the Staff Memo of record dated January 22, 2021”.

In addition to the above motion,

“I move to continue the Initial Architectural and Site Review for a new single-family detached condominium located at Lot 165, Unit 6, to [insert date certain] based on the evidence provided within the Staff Memo of record dated January 22, 2021.

/jjm



CENTRE SKY  
ARCHITECTURE LTD

---

10125 RANCHO MONTECITO DRIVE  
PARKER COLORADO 80138  
303.840.0020  
303.840.2299 F

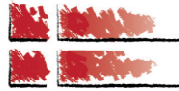

11 LONE PEAK DR #206; BOX 161488  
BIG SKY MONTANA 59716  
406.995.7572  
406.995.7477 F

---

T6 Project Narrative:

Located in Mountain Village, Unit 6 is a down sloping site off of Cortina Drive. The lot is heavily covered with fir, spruce and aspen trees. Unit 6 has great eastern sun exposure. It also has views of Mountain Village, and various peaks to the north east. Unit 6 is a ski in ski out lot and has a skier access easement on its western property boundary.

The proposed design for Unit 6 has a mountain modern architectural theme. Exterior materials include horizontal reclaimed wood siding, an ashlar stone layup, patina metal paneling, black window frames, and a grey standing seam roof. Public spaces of the Great Room, Grand Patio, Dining, and Ski room are pushed to the Northeast side of the site to take advantage of views. The garage is located closest to Cortina to allow for minimal grading and easy access. A lower level includes bedrooms, ski room, and family room that also face north east. Due to the home's small footprint & the steepness of the lot, a third, lowest level was designed that includes a mechanical room and bunk room.

Sincerely,

A handwritten signature in black ink, appearing to read 'J. Dugaard'.

Jamie Dugaard, AIA, NCARB, LEED ap

Principal Architect-Centre Sky Architecture

---

10125 RANCHO MONTECITO DRIVE  
PARKER COLORADO 80138  
303.840.0020  
303.840.2299 F

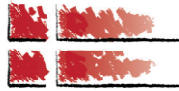

11 LONE PEAK DR #206; BOX 161488  
BIG SKY MONTANA 59716  
406.995.7572  
406.995.7477 F

---

## T6 Variance Criteria

- A- The strict development application of the CDC regulations would result in exceptional and undue hardship upon the property owner in the development of property lot because of special circumstances applicable to the lot such as size, shape, topography, or other extraordinary or exceptional physical conditions.
- The size, shape, topography, and other physical conditions such as the existing retaining wall & driveway on Unit 6 create extreme hardship on a very challenging site to build on. The topography on Unit 6 is exceptionally steep, especially working towards the southeast corner. Ninety-four percent of the buildable area is over 30% slope (see Exhibits A & B). Additionally, there is an existing 20'+ retaining wall along the south setback line that the home is required to be set back from for safety and future maintenance access. A shared driveway access takes the front setback area of the building, forcing the home to be pushed further back from the designated setback, and thus pushes the mass further downhill (See Exhibit C). The limited buildable area forces the home to be tight to the north and east property lines. The steep terrain and limited buildable area would not allow for a home with a main level to be constructed on this property without a height variance.
  - If we are held to height restrictions, the main level would need to move down 15-21 feet. This would force the current three-story home to become a two-story home. The home would also have to cut further into the hillside, decreasing natural light access & increasing excavation and structural complexities. The limited direct natural light access will create a larger usage and dependence on utilities.
- B- The variance can be granted without substantial detriment to the public health, safety, and welfare.
- A height variance has no effect on the public health, safety, and welfare.
- C- The variance can be granted without substantial impairment of the intent of the CDC
- This well-designed home responds to the topography, it will sit below the tree line, and will not impair any views of neighboring lots (see Exhibits D-G).
- D- Granting the Variance does not constitute a grand of special privilege in excess of that enjoyed by other property owners in the same zoning district, such as without limitation, allowing for a larger home size or building height than those found in the same zone district
- Multiple height variances have been approved on neighboring lots. We expect more to be requested as Units 1-5 are developed. The steep terrain & limited buildable area will not allow for a functional home design that meets the height restrictions (see Exhibit H).
- E- Reasonable use of the property is not otherwise available without granting of a variance, and the variance being granted is the minimum necessary to allow for reasonable use.

- a. If a variance is not granted, the home must be constructed with only a garage/entry on the entry level, and stairs down to the main common areas of the home. This would be a dysfunctional home design and would inhibit the lot from being built out.
  - b. The majority of home owners require a main level. Dropping the main level down to meet height requirements would add a vertical barrier to all users.
  - c. The roof responds to the topography, with the lowest point of the roof above the lowest grade in the north east corner (see exhibit I). Anything more limiting would not allow for a reasonable main floor area that aligns the areas exceptional quality of homes (see Exhibit J). The mass of the home is also recessed on the north east corner of the home.
- F- The lot for which the variance is being granted was not created in violation of town regulations or Colorado State Statues in effect at the time the lot was created
- G- The variance is not solely based on economic hardship alone
- a. Economic hardship is not a primary issue. The variance is requested to allow for a functional home design that will be a valuable asset to the community.
- H- The proposed variance meets all applicable Town regulations and standards unless a variance is sought for such regulations and standards
- a. All other regulations are met

Sincerely,

A handwritten signature in black ink, appearing to read "J. Daugaard". The signature is written in a cursive, flowing style.

Jamie Daugaard, AIA, NCARB, LEED ap

Principal Architect-Centre Sky Architecture

# NATURE OF LOT - STEEP SLOPES

**EXHIBIT A**

EXISTING GRADES IN THE SHADED AREA ARE GREATER THAN 30% SLOPE.  
94% OF AREA WITHIN SETBACKS IN SHADED

LOT 88 106AB-R

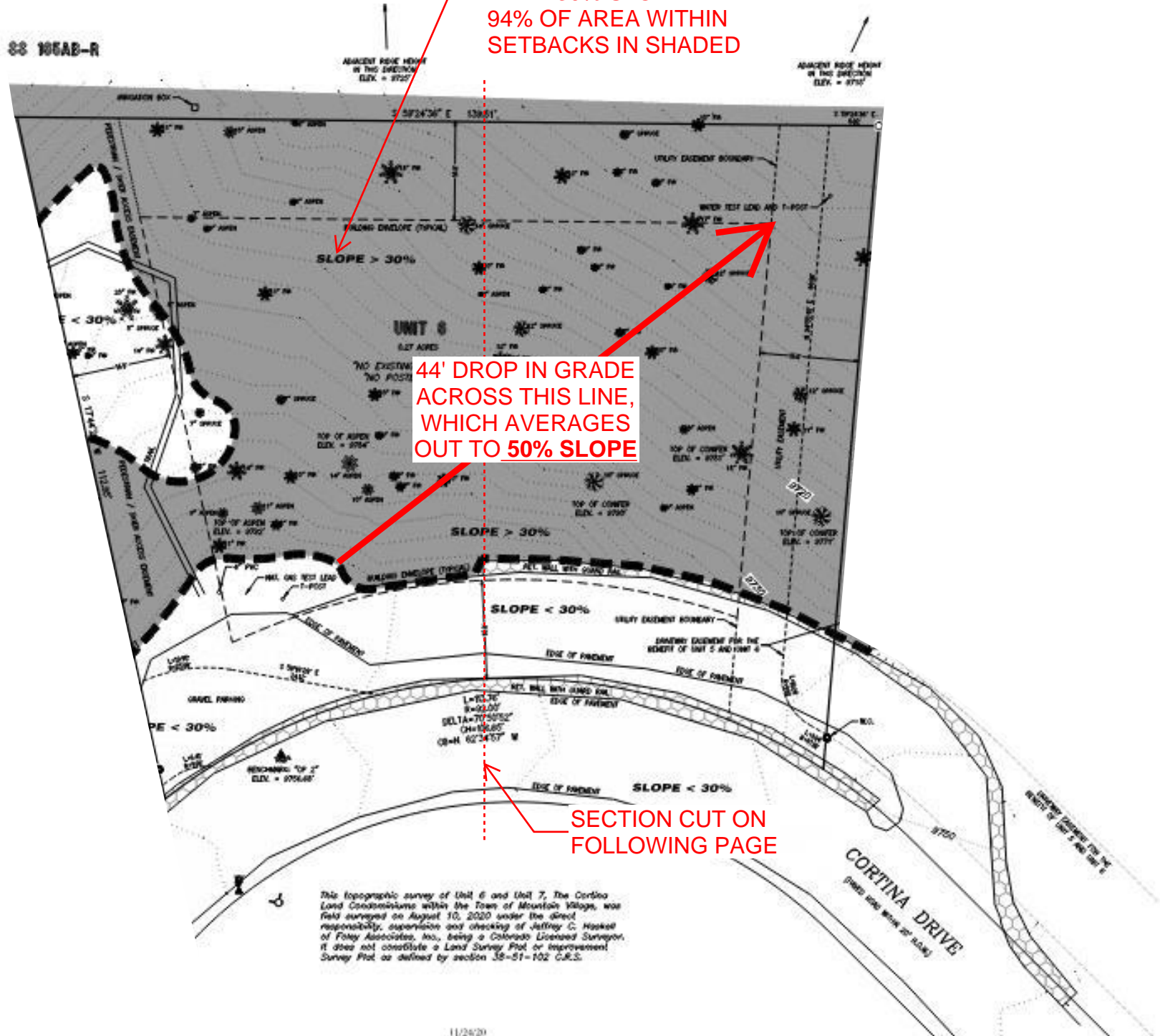

# NATURE OF LOT - STEEP SLOPES

**EXHIBIT B**

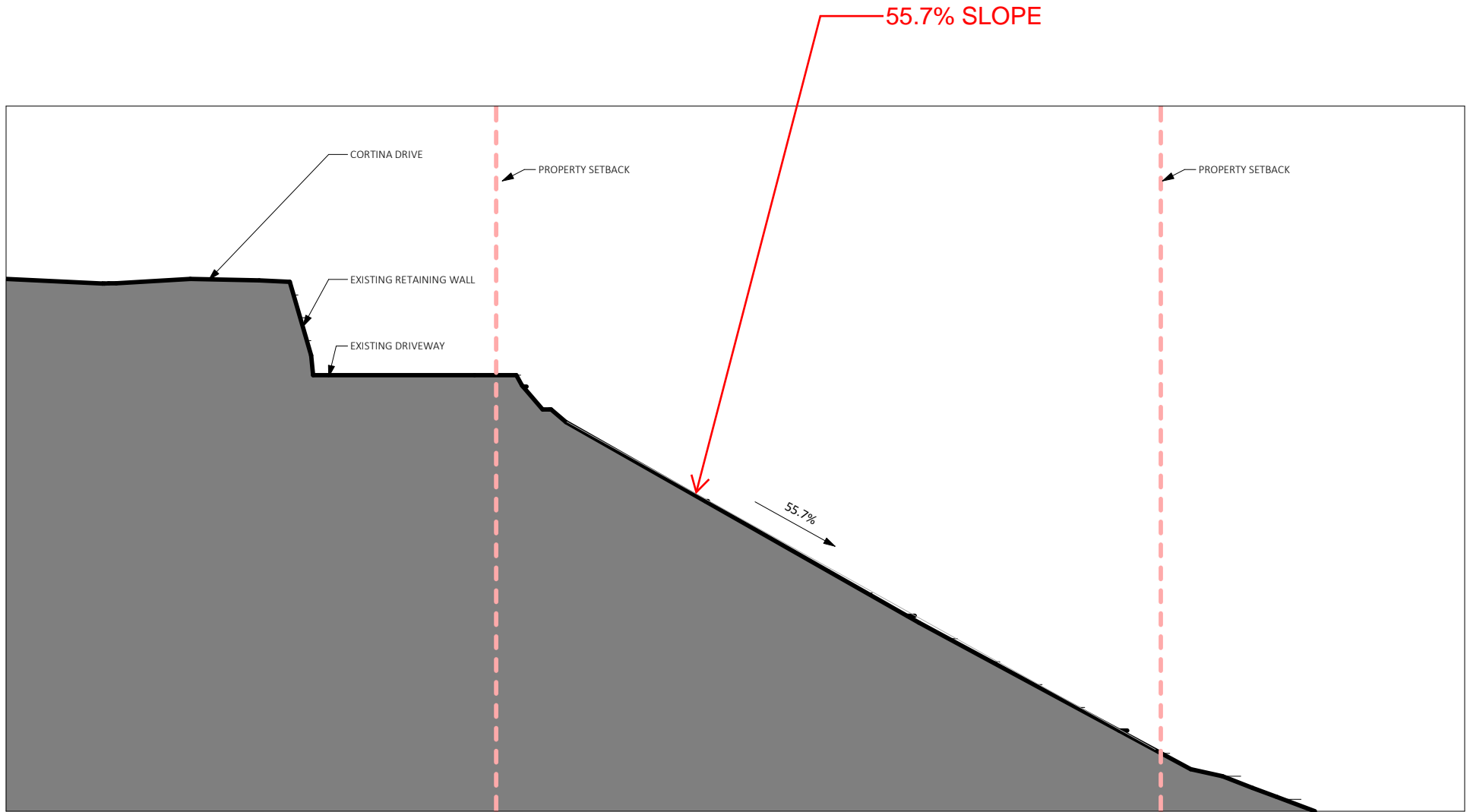

# NATURE OF LOT - ADDITIONAL LIMITING FACTORS

**EXHIBIT C**

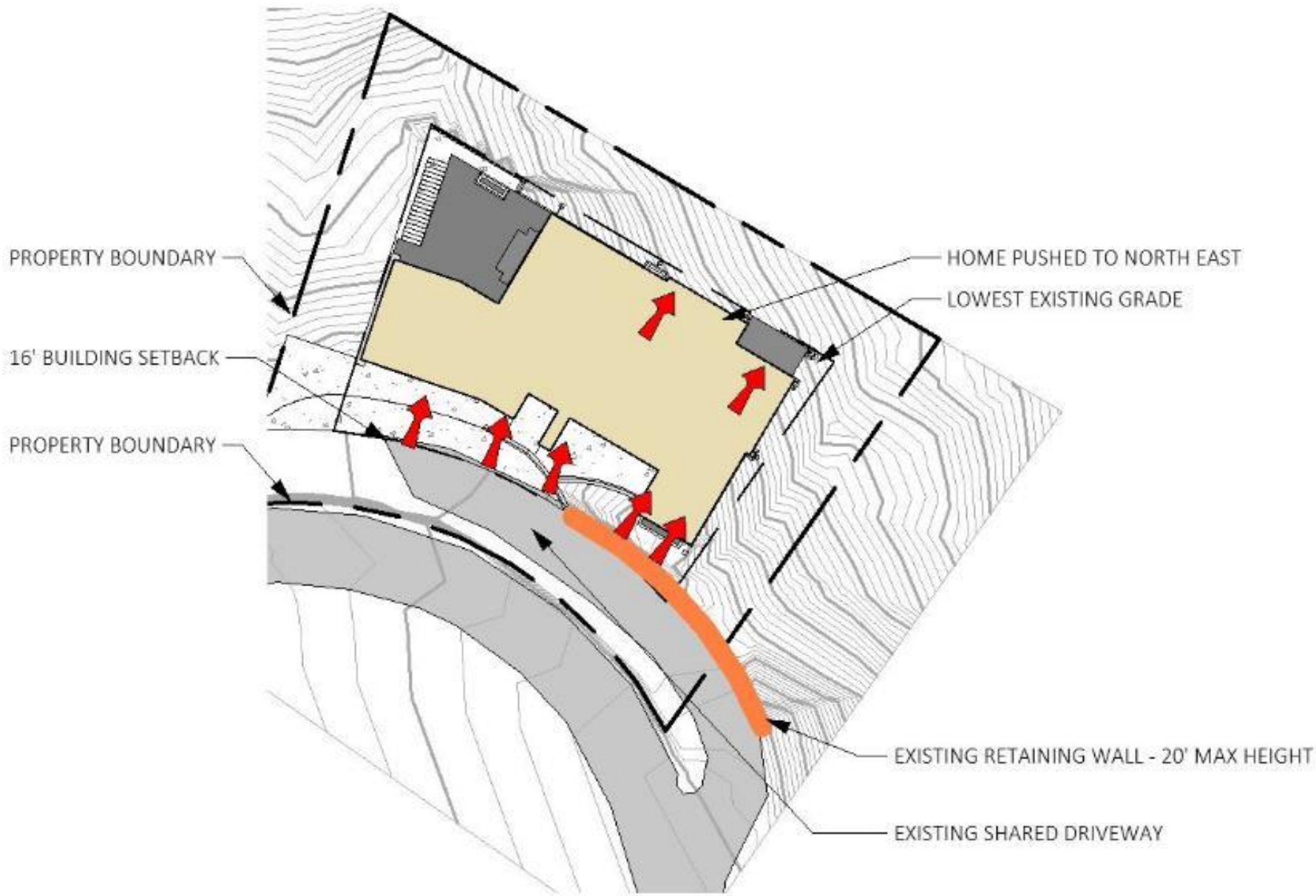



**PROPOSED  
UNIT 6 HOME**

SECTION  
CUT ON  
FOLLOWING  
PAGE

SAN JOAQUIN  
ROAD

EXISTING  
CASSIDY  
RIDGE  
CONDOS

PRIVATE  
DRIVEWAY

CORTINA DR

EXISTING  
HOME ON  
UNIT 22

# NO AFFECT ON NEIGHBORING PROPERTIES:

# EXHIBIT E

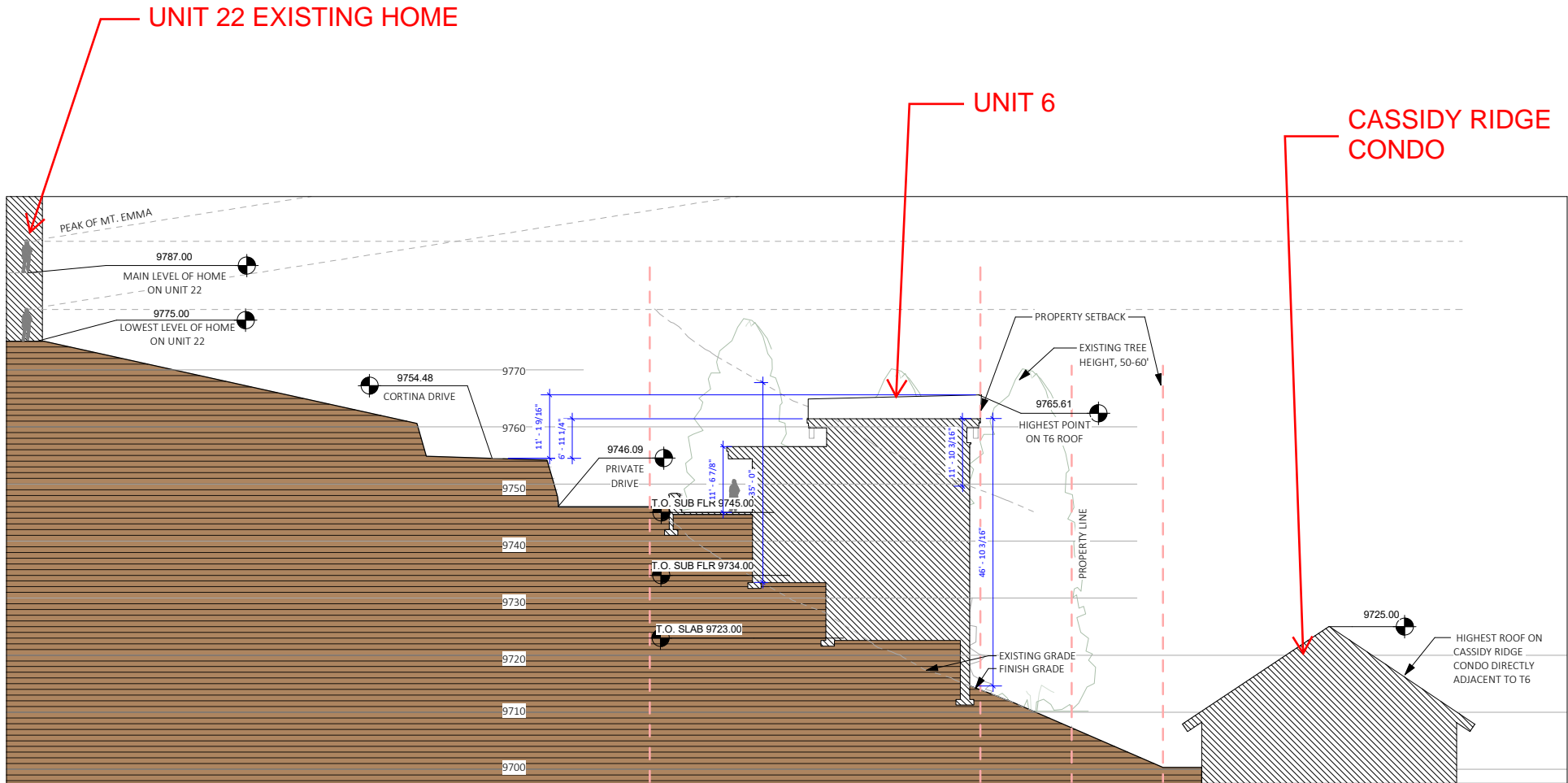



NO AFFECT ON NEIGHBORING PROPERTIES

**EXHIBIT F**

SAN SOPHIA MOUNTAIN RANGE

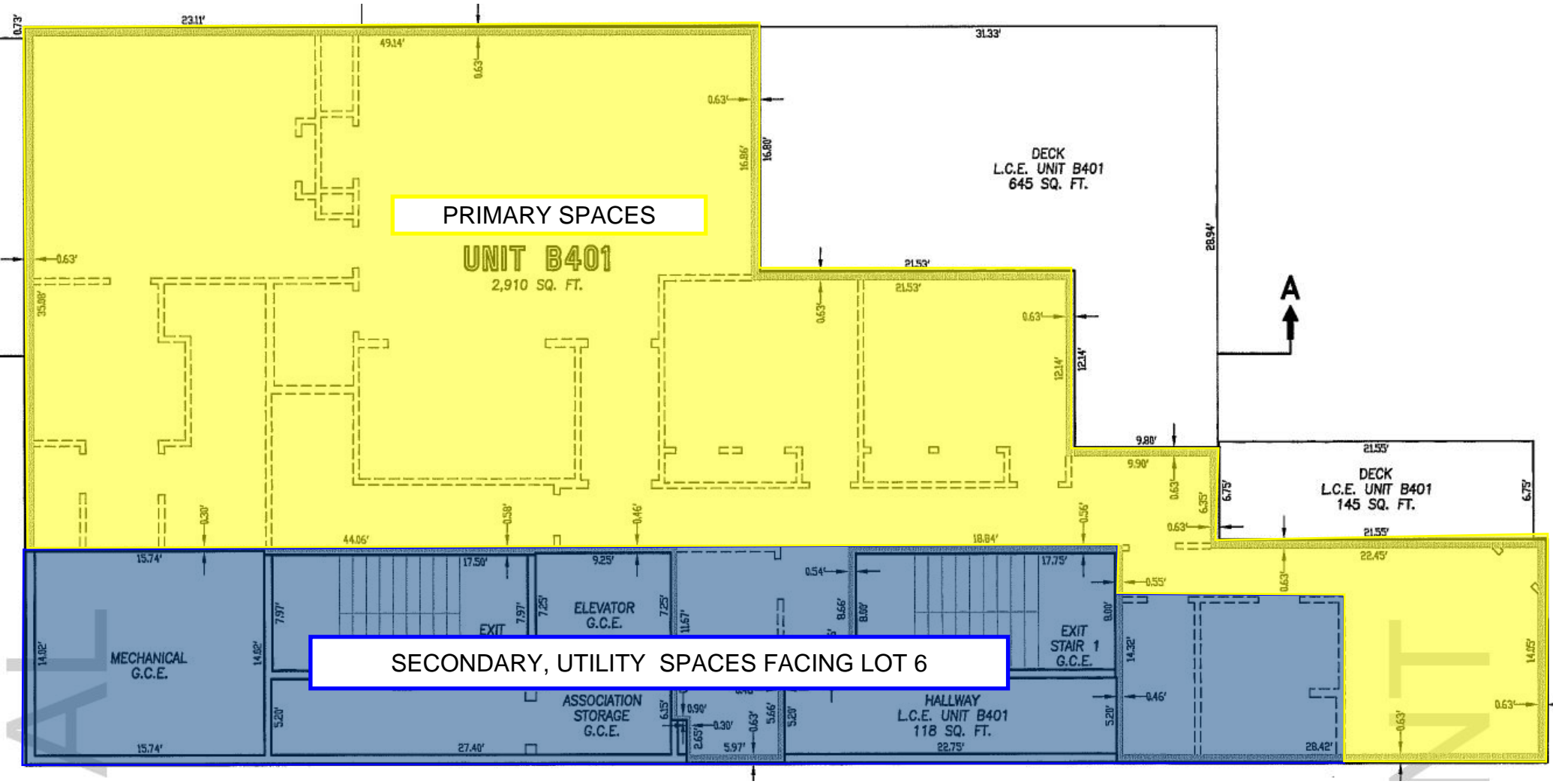

UNIT 6

EXISTING CASSIDY RIDGE CONDO - TOP LEVEL

# DESIGN RESPONDS TO EXISTING TOPOGRAPHY

## EXHIBIT G

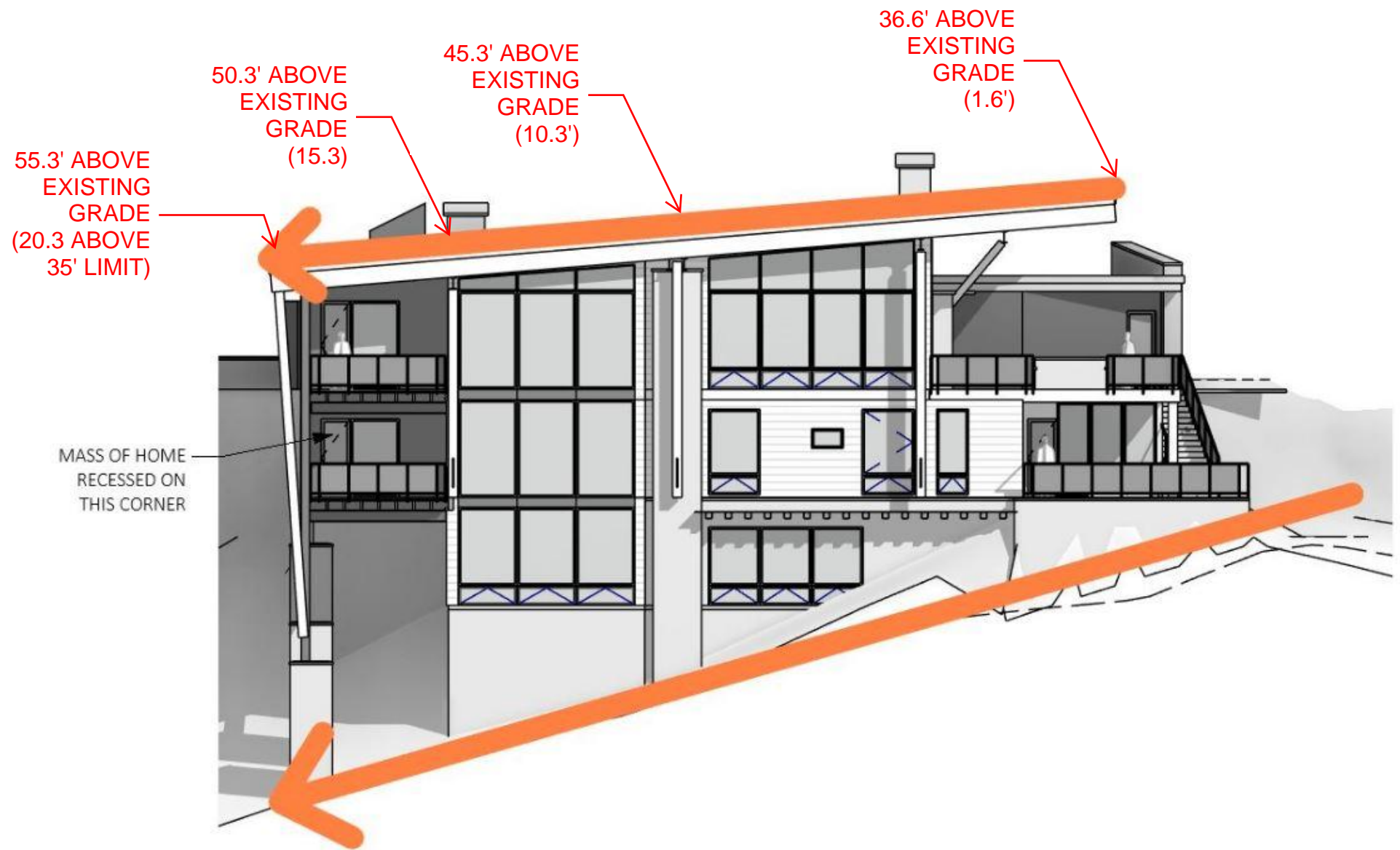

# FUTURE LOTS WITH SIMILAR SITE CONDITIONS: CORTINA UNITS 1-5

**EXHIBIT H**

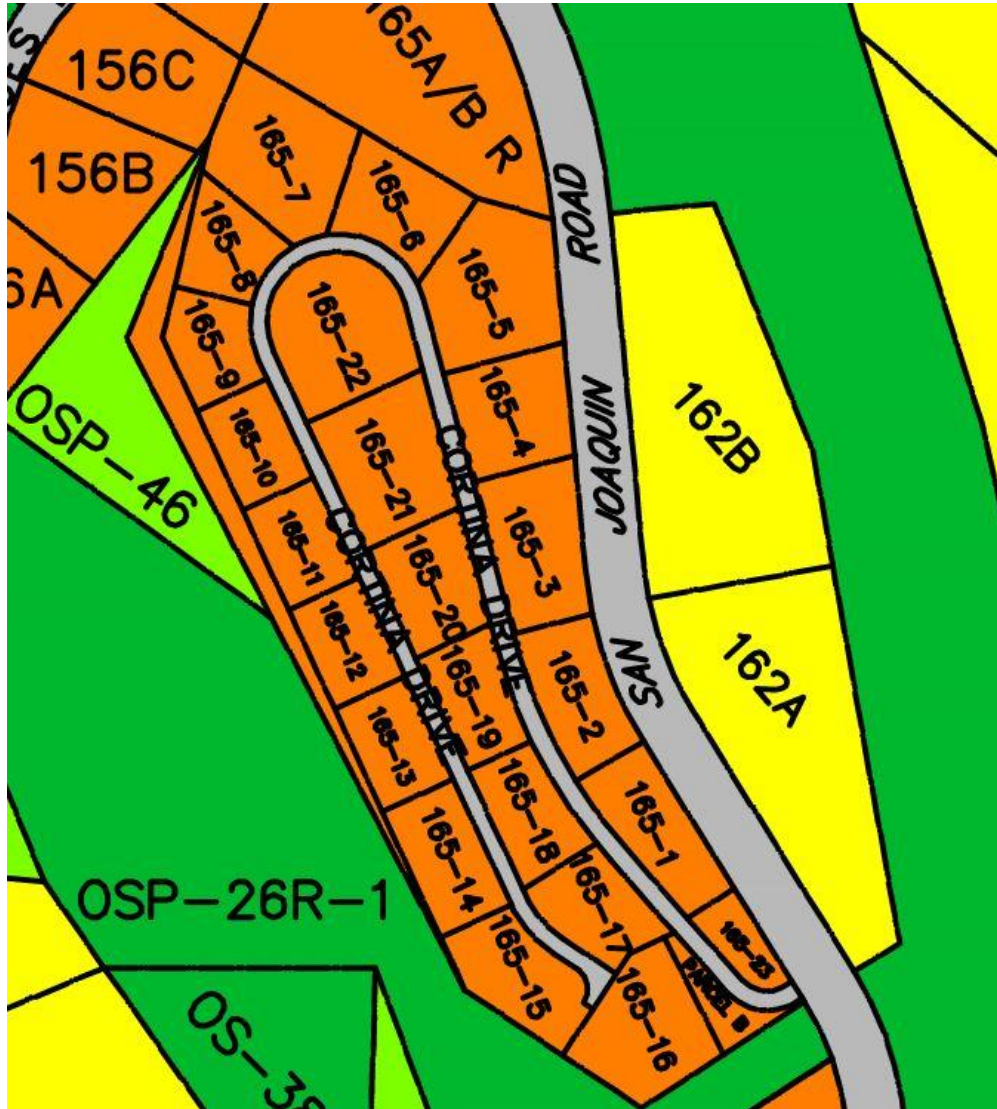

# VARIANCE REQUESTED

**EXHIBIT I**

**ACTUAL MAXIMUM BUILDING HEIGHT = 55.33'  
AT THIS POINT**

**MAXIMUM BUILDING HEIGHT = 35'**  
BUILDING HEIGHT SHALL BE MEASURED VERTICALLY AT A RIGHT ANGLE TO THE HORIZON LINE FROM ANY POINT ON A PROPOSED OR EXISTING ROOF OR EAVE (INCLUDING BUT NOT LIMITED TO THE ROOFING MEMBRANE) TO THE NATURAL GRADE OR FINISHED GRADE, WHICHEVER IS MORE RESTRICTIVE, LOCATED DIRECTLY BELOW SAID POINT OF THE ROOF OR EAVES.

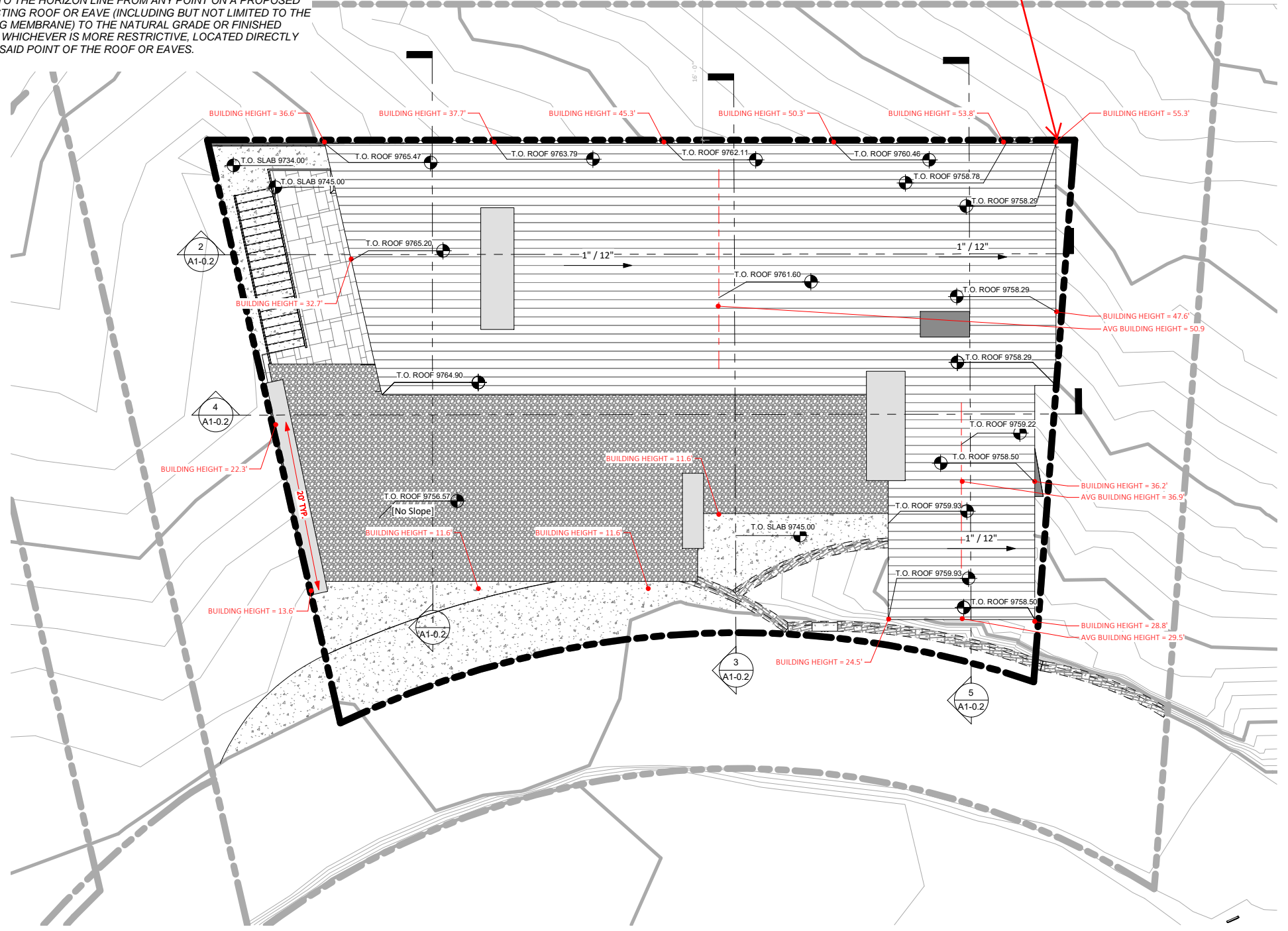

# DESIGNS OF HOMES THAT WOULD MEET HEIGHT VARIANCE

## THE APPLICATION WE WANT TO AVOID



## DEACTIVATION OF STRUCTURE



# TELLURIDE #6

TELLURIDE, CO 81435



NOTE:  
RENDERINGS MAY DIFFER FROM CONSTRUCTION PLANS.  
CONSTRUCTION PLANS ARE DEEMED TO BE ACCURATE.



**CENTRE SKY**  
ARCHITECTURE LTD

ISSUE # \_\_\_\_\_

T6

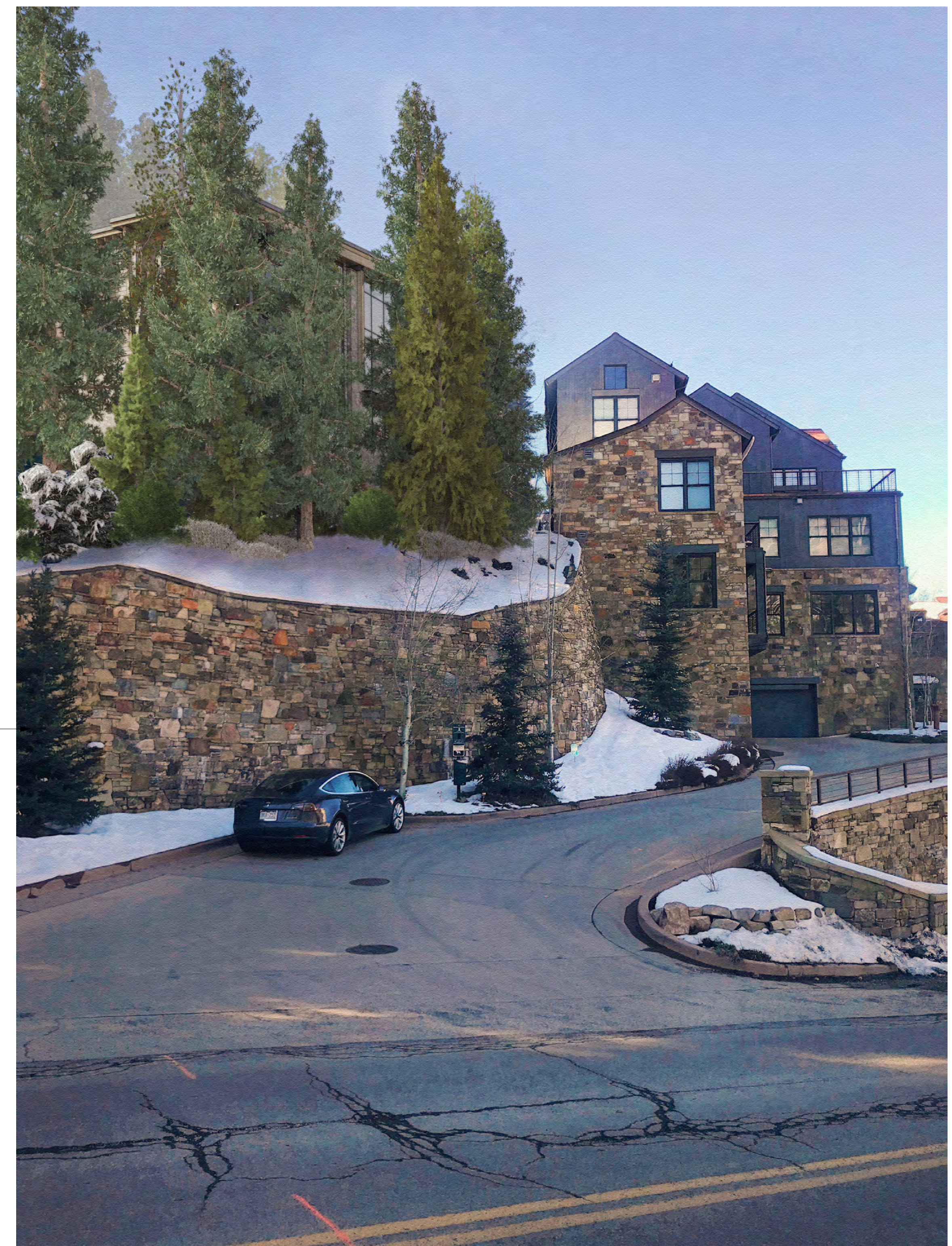

← ORIGINAL PHOTO OF EXISTING VIEW FROM SAN JOAQUIN ROAD

→ RENDERED PHOTO TO SHOW APPROXIMATE VIEW OF UNIT 6 HOME FROM ROAD

NOTE:  
RENDERINGS MAY DIFFER FROM CONSTRUCTION PLANS.  
CONSTRUCTION PLANS ARE DEEMED TO BE ACCURATE.

VIEW FROM SAN JOAQUIN ROAD LOOKING UP AT UNIT 6

# TELLURIDE #6

TELLURIDE, CO 81435

CENTRE SKY ARCHITECTURE, LTD.

## CENTRE SKY ARCHITECTURE, LTD.

11 Lone Peak Dr. #206  
P.O. Box 161488  
Big Sky, MT. 59716  
Phone: (406) 995-7572 Fax: (406) 995-7477  
E-mail: sara@centresky.com  
Website: www.centresky.com

## TRAUTNER GEOTECH

Jonathan Butler, P.E.  
970-759-3113 (Cell)

95 North Henry St.,  
Cortez, Colorado  
970-529-2020 (Cortez)

649 Tech Center Dr.,  
Durango, Colorado  
970-259-5095 (Durango)

SCHEMATIC DESIGN/ INITIAL DRB SUBMITTAL

## ARCHITECTURE

## MICHAEL TALBOTT

13905 River Glen Ln.  
Prospect, KY 40059  
Cell: (502) 415-2280  
E-mail: mtalbott1@gmail.com

## GEOTECHNICAL ENGINEER

## LUX WEST PROPERTIES

Bruce McIntyre  
Phone: (970) 729-0970  
E-mail: bruce@luxwest.com

## LUX WEST INTERIORS

327 E Colorado Ave.  
P.O. Box 1552  
Telluride, CO 81435  
Phone: (970) 728-8238  
E-mail: barbara@luxwest.com

## CLIENT

## FINBRO CONSTRUCTION

70 Pilot Knob Lane  
Telluride, CO 81435

## CLIENT REPRESENTATIVE

## ALPINE LAND CONSULTING, LLC.

P.O. Box 234  
Rico, CO 81332  
Phone: (970) 708-0326  
E-mail: gregg@alpinelandconsulting.com  
Website: alpinelandconsulting.com

## INTERIOR DESIGN

FINBRO CONSTRUCTION

## GENERAL CONTRACTOR

## CIVIL ENGINEER

CENTRE SKY  
ARCHITECTURE, LTD.  
ARCHITECTURE  
&  
PLANNING

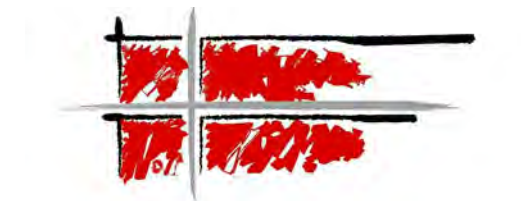

COLORADO:  
10125 RANCHO MONTECITO  
DR. PARKER, COLORADO 80138  
P.303.840.0020

MONTANA:  
P.O. BOX 161488  
11 LONE PEAK DR., UNIT 206  
BIG SKY, MONTANA 59716  
P.406.995.7572

UTAH:  
1960 SIDEWINDER DR., #101  
PARK CITY, UTAH 84060  
P.435.604.0891

www.centresky.com

JANUARY 14, 2021

## CODE ANALYSIS

ZONING:	R-1	BUILDING DEPT.:	STATE OF COLORADO - SAN MIGUEL COUNTY (970)728-3923
OCCUPANCY:	TYPE V NON RATED	BUILDING DEPT. PHONE:	2018 INTERNATIONAL RESIDENTIAL CODE
CONSTRUCTION TYPE:		CODE JURISDICTION:	2018 INTERNATIONAL PLUMBING CODE
ALLOWABLE FLOOR AREA:			2018 INTERNATIONAL MECHANICAL CODE
FIRE SUPPRESSION:	REQUIRED - NFPA 13D		2018 FUEL GAS CODE
IRRIGATION:	REQUIRED - MOUNTAIN VILLAGE CDC.		2020 NATIONAL ELECTRICAL CODE
BEARING & NON-BEARING EXTERIOR WALLS:	NON RATED		2018 INTERNATIONAL ENERGY CONSERVATION CODE
INTERIOR BEARING WALLS:	NON RATED		2018 INTERNATIONAL FIRE CODE
STRUCTURAL FRAME:	NON RATED	SHAFT ENCLOSURES:	TOWN OF MOUNTAIN VILLAGE & SAN MIGUEL COUNTY PRESCRIPTIVE ENERGY CODE & GREEN BUILDING STANDARDS
		ROOF/ROOF CEILING:	NONE
			CLASS-A ROOF CONSTRUCTION REQUIRED

ZONING DISTRICT	LOT COVERAGE	MAXIMUM BUILDING HEIGHT	AVERAGE BUILDING HEIGHT	PARKING SPACES
MULTI-FAMILY				
REQUIRED	< 40% OF LOT	35' - 0"	30' - 0"	2
ACTUAL	39% OF LOT	55' 4" (VARIANCE REQUESTED)	32' - 10" (VARIANCE REQUESTED)	2

## AREA ANALYSIS

**DEFINITIONS:**  
**SQUARE FOOT:** LIVABLE FLOOR AREA AS MEASURED FROM EXTERIOR FACE OF STUD OR FACE OF CONCRETE WALL, INCLUDING THICKNESS OF ALL WALLS, INTERIOR AND EXTERIOR (EXCLUDING EXTERIOR FINISHES); DOES NOT INCLUDE HIREPLACE BUMP-OUTS, MECHANICAL SPACES, GARAGE SPACES, AND UNFINISHED BASEMENT AND/OR ATTIC SPACE.  
**GROSS SQUARE FOOT:** TOTAL BUILDING AREA AS MEASURED FROM EXTERIOR DIMENSIONS INCLUDING THICKNESS OF ALL WALLS, INTERIOR AND EXTERIOR (EXCLUDING EXTERIOR FINISHES), MECHANICAL SPACES, GARAGE SPACES, AND ACCESSIBLE UNFINISHED SPACE; DOES NOT INCLUDE CRAWL SPACES, PATIOS AND DECKS.

PROJECT SQUARE FOOTAGE		
LEVEL	NAME	AREA
T.O. ROCK BOTTOM	LIVING	1416 SF
T.O. SLAB	LIVING	2829 SF
T.O. SUB FLR	LIVING	2447 SF
HABITABLE		6692 SF
T.O. ROCK BOTTOM	MECH	300 SF
T.O. SUB FLR	GARAGE	659 SF
NON HABITABLE		958 SF
GROSS AREA		7651 SF

## SITE INFORMATION

POWER: SAN MIGUEL POWER ASSOCIATION  
1-888-864-7311  
CITY: CITY  
CITY: CITY  
SOURCE GAS: (970) 728-6141  
TELEPHONE SERVICE:  
UNDERGROUND UTILITY LOCATE: 811  
FIRE DEPT: TELLURIDE FIRE PROTECTION DISTRICT  
FIRE DEPT. PHONE: (970) 729-2611 CHIEF / INSPECTOR - J. CHEROSKE  
DEFENSIBLE SPACE: 30 FEET IS RECOMMENDED  
GEOTECHNICAL REPORT: TRAUTNER GEOTECH  
COPIES AVAILABLE UPON REQUEST

## DESIGN CRITERIA

BASIC WIND SPEED: 90 MPH/3 SEC. GUST (VERIFY W/ STRUCTURAL ENG.)  
SEISMIC DESIGN CATEGORY: "C" (VERIFY WITH STRUCTURAL ENG.)  
FROST DEPTH: -PSF (VERIFY WITH STRUCTURAL ENGINEER)  
SNOW LOADS: REFER TO STRUCTURAL DRAWINGS.  
FOUNDATION STANDARD: GENERAL NOTES & FOUNDATION DETAILS.

## ABBREVIATIONS

AB	anchor bolt	DWG	drawing	HT	height	PC	pumice-crete	STN	stone
ABV	above	DWR	drawer	HTG	heating	PERF	perforate	STIFF	stiffener
AAC	autoclaved aerated concrete	E	east, egress	HW	hardwood	PERM	perimeter	STD	storage
ADJ	adjacent	EA	each	HVAC	heat/ventilate/air condition	PL	plaster	STR	structural
AFF	above finished floor	EJ	electric hand dryer	ID	inside diameter	PLAM	plastic laminate	SUSP	suspended
AGG	aggregate	EHD	elctric hand dryer	INCL	include (d) (ing)	PLAS	plastic	SV	stacked ovens
ALUM	aluminum	EJ	expansion joint	INSUL	insulate (d) (ion)	PLF	pounds per lineal feet	T	tread
ALT	alternate	EL	elevation	IRC	international residential code	PLT	plate	TB	towel bar
ARCH	architect (ural)	ELEC	electric (al)	IRT	international residential code	PNT	panel	TC	terra cotta
ASPH	asphalt	EPDM	elastomeric membrane	IRV	invert	PR	pair	TEL	telephone
A/C	air conditioning	EQ	equal	IT	invert	PSF	pounds per square foot	THK	thick (ness)
AVG	average	EWAC	electric water cooler	JST	joist	PSI	pounds per square inch	TOW	top of
BD	board	EXIST	existing	JT	joint	PTD	paper towel dispenser	TOC	top of concrete
BUDS	building	EZH	exhaust	KIT	kitchen	PTN	partition	TOS	top of steel
BUX	block	EXT	exterior	KO	knockout	PVC	polyvinyl chloride	TPH	toilet paper dispenser
BULK	blocking	FC	faucet	L	length, angle	PVMT	pavement	TR	trash compactor
BO	bottom	FD	floor drain	LAB	laboratory	PWD	plywood	TS	television
BOF	bottom	FE	fire extinguisher	LAM	laminated (d)	QT	quarry tile	TV	typical
BR	bedroom	FEC	fire extinguisher cabinet	LAV	lavatory	R	riser, radius	T&G	torque and groove
BRG	bearing	FF	factory finish	LB	pound	R/A	return air	UBC	uniform building code
BSMT	basement	FFN	finished floor elevation	LBL	label	RB	rubber base	UE	underground electric
BUR	built up roofing	FLG	flashing	LF	lineal feet	RCP	reference ceiling plan	UL	underwriters laboratory
		FLR	floor (ing)	LL	live load	RO	roof drain	UNO	unless noted otherwise
		FLUR	fluorescent	LT	light	RE	reference	VCT	vinyl composition tile
		FND	feminine napkin dispenser	LWC	lightweight concrete	RF	refrigerator	VERT	vertical
C	channel	FNV	feminine napkin vendor	MAS	masonry	RG	range	VR	vapor retarder
CAB	cabinet	FOC	face of concrete	MATL	material (s)	REG	register	W	west, wide, width
CB	catch basin	FOF	face of finish	MAX	maximum	REQD	required	W/C	watercloset
CG	corner guard	FOS	face of stud	MED	medicine cabinet	REV	revision (s), revised	WD	wood
CTR	center	FPM	face of masonry	MECH	mechanic (al)	RFG	roofing	W/D	with
CI	cast iron	FRMG	framing	MTL	metal	RM	room	WF	wire flange
CJ	central joint	FT	foot	MFR	manufacture (r)	RO	rough opening	WG	wire glass
CL	ceiling	FTG	fasting	MH	manhole	ROW	right of way	WI	wrought iron
CLG	closet	FUT	future	MISC	miscellaneous	RS	rough sawn	W/O	without
CLR	clear (ance)			ML	microlam	RUB	rubber	WR	warming drawer
CMU	concrete masonry unit			MLD	molding, moulding	RVW	refrigerator drawers	WS	water supply
CMA	carbon monoxide alarm			MMB	membrane	S	south	WWF	welded wire fabric
CO	clean out			MOM	masonry opening	SA	smoke alarm		
COL	column			MOV	movable	S/A	supply air		
CONC	concrete			MT	mount (ed) (ing)	SAG	suspended acoustic grid		
CONCT	construction			MW	microwave oven	SC	solid core		
CONT	continuous or continue			N	north	SCH	schedule		
CORR	corridor			NAT	natural	SD	storm drain		
CPT	carpet (ed)			NIC	not in contract	SECT	section		
CSMT	ceramic tile			NMC	nominal	SHT	sheathing		
CT	ceramic tile			NMS	nominal	SIM	similar		
CY	clothes dryer			NTS	not to scale	SN	sink		
CW	clothes washer					SPD	soap dispenser		
						SPR	specification		
DBL	double					SPR	speaker		
DF	drinking fountain					SQL	square		
DH	double hung					SS	service sink		
DIAG	diagonal					ST	steel		
DIAM	diameter					STD	standard		
DIM	dimension (s)								
DISP	dispenser								
Ds	dead load								
DN	down								
DR	drain disposal								
DR	door								
DS	downspout								
DTL	detail								
DW	dish washer								

## VICINITY MAP

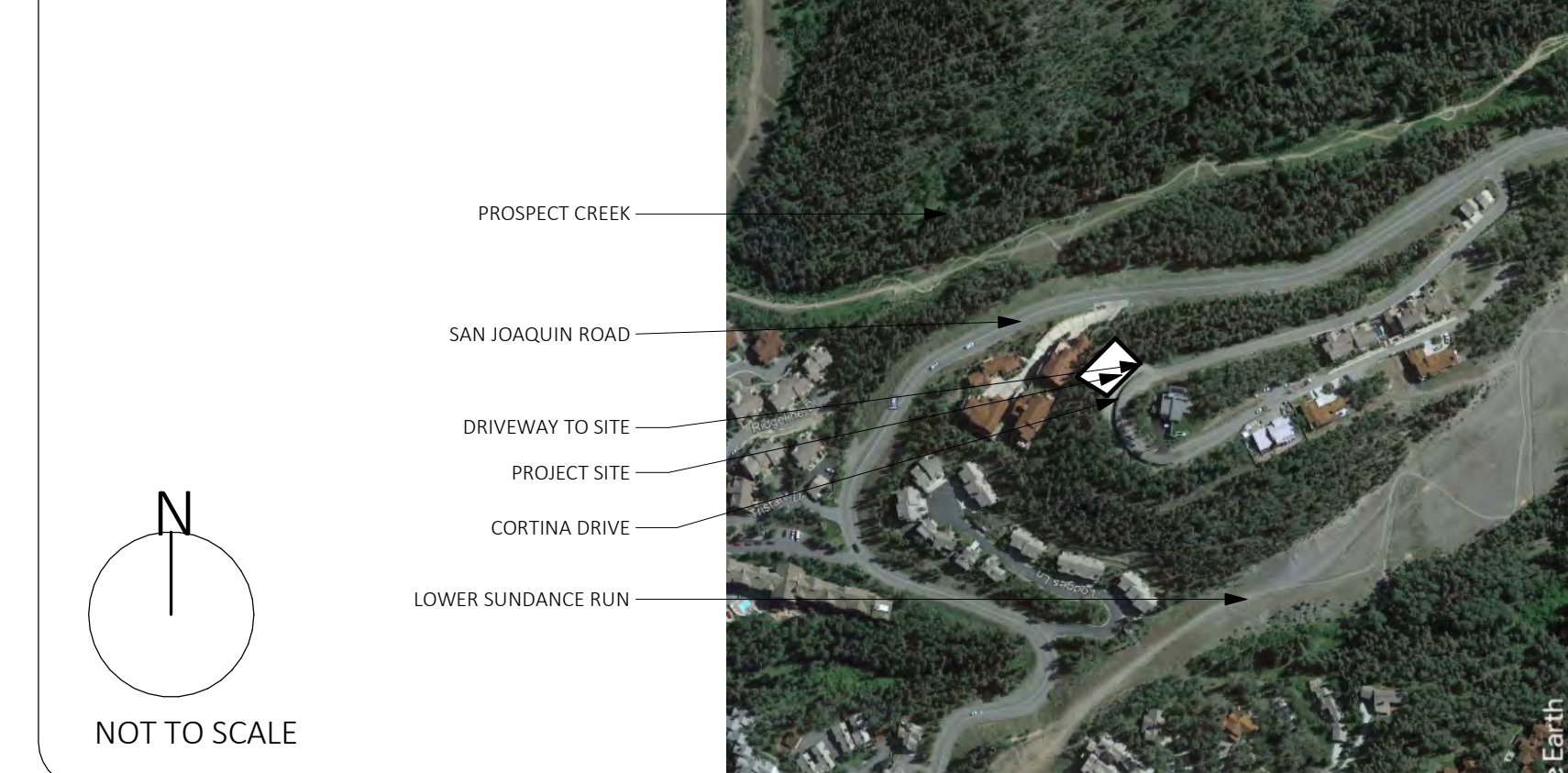

## SHEET INDEX

COVER	COVER
D1	PERSPECTIVES
T1-0.1	TITLE SHEET
GENERAL	
A0-0.0	GENERAL NOTES
A0-0.2	MATERIAL SPECIFICATIONS
A0-0.3	AREA PLANS
CIVIL	
C1-0.0	SURVEY
C1-0.1	GRADING
C1-0.2	DRAINAGE
C1-0.3	UTILITY
ARCHITECTURAL	
A1-0.1	ARCHITECTURAL SITE PLAN
A1-0.2	SITE SECTIONS
A1-0.3	SITE DETAILS
A1-1.0	LOWER LEVEL PLAN
A1-1.1	MAIN LEVEL PLAN
A1-3.1	ROOF PLAN
A1-3.2	ROOF PLAN & TOPO SURVEY
A2-0.1	EXTERIOR ELEVATIONS
A2-0.2	EXTERIOR ELEVATIONS
A5-1.2	EXTERIOR DETAILS
A6-1.2	WINDOW SCHEDULE
A6-2.1	DOOR ELEVATIONS & SCHEDULE

## GRAPHIC SYMBOLS

	POINT ELEVATION POINT ELEVATION DESCRIPTION		NEW CONCRETE
	EXTERIOR ELEVATION MARKER		PUMICE-CRETE RAMMED EARTH RASTRA PANELS
	BUILDING SECTION & SECTION DETAIL MARKER		TIMBER OR LOG ELEMENT
	INTERIOR WALL ELEVATION MARKER		INSULATION
	ROOM NAME ROOM NUMBER		EARTH
	DOOR INDICATOR		ASPHALT
	WINDOW TYPE		WALL TO BE REMOVED
	WALL TYPE		EXISTING WALL TO REMAIN
	DATUM POINT		NEW WALL
	BREAK LINE		

## KEY PLAN

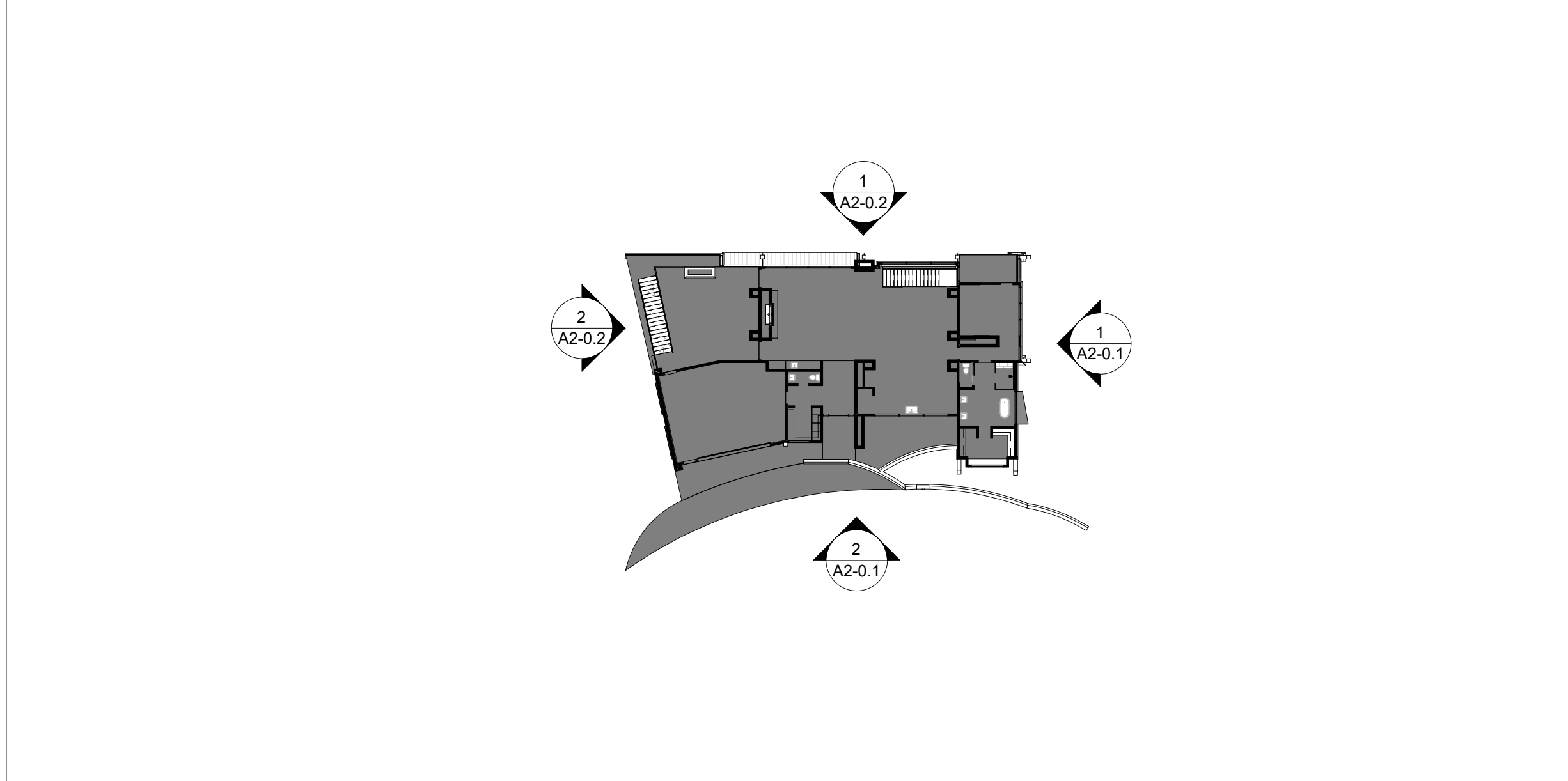

TELLURIDE #6  
TELLURIDE, CO 81435

NOT FOR  
CONSTRUCTION

Issued For: \_\_\_\_\_ Date: \_\_\_\_\_  
100% S.D.: 01/14/2021  
Pricing #: \_\_\_\_\_  
ARC Sketch Review: 01/14/2021  
100% D.D.: \_\_\_\_\_  
ARC Final Review: \_\_\_\_\_  
100% C.D.: \_\_\_\_\_  
REV. #: \_\_\_\_\_

Drawn By: S. D'AGOSTINO  
Date: 01/14/2021  
Project #: 2021.00  
Phase: SD  
Sheet

T1-0.1  
TITLE SHEET



# GENERAL NOTES

GENERAL NOTES ARE INDENTED TO HIGHLIGHT OR IN SOME CASES SUPPLEMENT PROJECT SPECIFICATIONS. REFER TO THE PROJECT SPECIFICATIONS FOR COMPLETE WORK COVERAGE.

- ALL CONSTRUCTION INCLUDED UNDER THIS CONTRACT SHALL BE IN COMPLIANCE WITH ALL APPLICABLE FEDERAL, STATE & LOCAL CODES, STANDARDS, REGULATIONS, ORDINANCES, SPECIFICATIONS AND ANY APPLICABLE DESIGN OR ARCHITECTURAL REVIEW COMMITTEES. THE GENERAL CONTRACTOR SHALL BE RESPONSIBLE FOR OBTAINING ALL NECESSARY PERMITS APPLICABLE TO THIS PROJECT.
- THE GENERAL CONTRACTOR IS RESPONSIBLE FOR SCHEDULING ON-SITE REVIEWS BY BOTH THE GEOTECHNICAL ENGINEER AND STRUCTURAL ENGINEER AT THE APPROPRIATE CONSTRUCTION PHASES AS SET FORTH BY EACH SPECIALTY.
- GENERAL CONTRACTOR/CONSTRUCTION MANAGER AS WELL AS SUB-CONTRACTORS SHALL BE FAMILIAR WITH & COMPLY TO ALL PROCEDURES SET FORTH BY FEDERAL, STATE, AND LOCAL GOVERNING AGENCIES IN THE CONSTRUCTION OF THIS PROJECT. IT IS THE GENERAL CONTRACTOR'S RESPONSIBILITY TO FURNISH ALL AFFIDAVITS, CERTIFICATES, & REPORTS THAT MAY BE REQUIRED BY ANY & ALL AGENCIES INCLUDING ANY APPLICABLE DESIGN OR ARCHITECTURAL REVIEW COMMITTEES UPON REQUEST.
- ALL CONSTRUCTION DOCUMENTS ARE BASED ON THE ACCURACY OF THE EXISTING RECORD DRAWINGS. IT SHALL BE THE RESPONSIBILITY OF THE GENERAL CONTRACTOR/CONSTRUCTION MANAGER AND TRADE CONTRACTORS TO VERIFY EXISTING CONDITIONS, AND DIMENSIONS PRIOR TO THE INSTALLATION OF ANY NEW WORK OR REMEDIATION OF EXISTING CONSTRUCTION. IF ANY DISCREPANCIES ARE FOUND BETWEEN THE EXISTING CONDITION AND THE CONSTRUCTION DOCUMENTS THE ARCHITECT SHALL BE NOTIFIED IMMEDIATELY.
- INTERRUPTION OF EXISTING UTILITIES AND SERVICES AS NECESSARY MUST BE COORDINATED WITH THE OWNER'S REPRESENTATIVE WITH A MINIMUM OF 72 HOURS PRIOR NOTICE. THESE SERVICE INTERRUPTIONS INCLUDE BUT ARE NOT LIMITED TO: WATER, POWER, SANITARY SEWER, GAS, TELEPHONE, CABLE, ETC.
- CONTRACTORS SHALL COMPLY WITH ALL CONSTRUCTION DOCUMENTS, INCLUDING OUTLINE SPECIFICATIONS. DO NOT SCALE DRAWINGS! FOLLOW DIMENSIONS AS PER PLANS. NOTIFY ARCHITECT OF ANY CONFLICTS.
- SPECIFICATIONS AND DRAWINGS INCLUDE FINISHED STRUCTURE. BUILDER SHALL BE RESPONSIBLE FOR CONSTRUCTION METHODS, PROCEDURES, AND CONDITIONS (INCLUDING SAFETY), EXCEPT AS SPECIFICALLY INDICATED OTHERWISE IN THE CONTRACT DOCUMENTS.
- CONTRACTORS AND SUB-CONTRACTORS SHALL RIGIDLY ADHERE TO ALL LAWS, CODES, AND ORDINANCES WHICH APPLY TO THIS WORK. THEY SHALL NOTIFY AND RECEIVE CLARIFICATION FROM ARCHITECT IN WRITING OF ANY VARIATIONS BETWEEN CONTRACT DOCUMENTS AND GOVERNING REGULATIONS.
- PRIOR TO MATERIAL FABRICATION, SHOP DRAWINGS SHALL BE SUBMITTED TO THE ARCHITECT/ENGINEER FOR CONFORMANCE TO DESIGN. REFER TO NOTES BELOW ON "SHOP DRAWINGS" AS WELL AS STRUCTURAL ENGINEER'S GENERAL NOTES FOR FURTHER INFORMATION. THE CHECKING OF SHOP DRAWINGS BY THE ARCHITECT OR ENGINEER IN NO WAY RELIEVES THE CONTRACTOR OF FULL RESPONSIBILITY FOR ACCURATE COMPLETION OF THE WORK AS DRAWN AND SPECIFIED.
- IT IS THE CONTRACTOR'S RESPONSIBILITY TO ENSURE THAT ALL WALL TYPES CONFORM TO STRUCTURAL SHEAR WALL REQUIREMENTS. REFER TO STRUCTURAL DRAWINGS FOR FURTHER INFORMATION.
- PREVENT SCREEN WALL AT ALL EXTERIOR MECHANICAL EQUIPMENT. SCREEN WALL TO BE AT A MIN. HEIGHT OF 1'-0" ABOVE THE MECHANICAL EQUIPMENT, UNLESS NOTED OTHERWISE.
- A RADON MITIGATION SYSTEM SHALL BE INSTALLED UNDER ALL CONCRETE SLABS.
- GUARDRAILS ARE REQUIRED AT ANY LOCATION HAVING A VERTICAL DROP GREATER THAN 30 INCHES AND ARE TO BE 36" MINIMUM IN HEIGHT.
- OPEN GUARDRAILS AND STAIR RAILINGS SHALL HAVE INTERMEDIATE RAILS OR AN ORNAMENTAL PATTERN SUCH THAT A SPHERE 4 INCHES IN DIAMETER CANNOT PASS THROUGH.
- INSTALL HANDRAILS AT ALL STAIRS HAVING MORE THAN TWO RISERS, UNLESS SHOWN OTHERWISE. HANDRAILS TO BE NOT LESS THAN 34 INCHES, NOR MORE THAN 38 INCHES ABOVE NOSING OF TREADS.
- CONCRETE SIDEWALKS TO HAVE 3/4" TOLDED JOINTS AT 3'-0" O.C. UNLESS NOTED OTHERWISE.
- ALL CONCRETE SLABS ON GRADE TO HAVE SLIP SHEETS INSTALLED BETWEEN SLAB AND SUBGRADE.
- EVERY EFFORT IS MADE TO PROVIDE COMPLETE AND ACCURATE INFORMATION. IF THERE IS ANY CONFLICTING INFORMATION OR OMISSIONS IN THE WORKING DRAWINGS OR SUPPLEMENTAL DOCUMENTS, IT IS THE GENERAL CONTRACTOR'S RESPONSIBILITY TO COORDINATE WITH THE ARCHITECT FOR A RESOLUTION.
- PREVENT INSULATION AS FOLLOWS IN COMPLIANCE WITH 2012 IECC, SEE TABLE 402.1.1 FOR FULL DETAILS.
  - CEILING - R-49 MIN.
  - WOOD FRAME WALL MASS WALL - R-15 MIN. CONTINUOUS INSULATED SHEATHING ON THE INTERIOR OR EXTERIOR OF THE HOME; OR IF MORE THAN HALF OF THE INSULATION IS ON THE INTERIOR OF THE MASS WALL, R-19 MIN. CAVITY INSULATION AT THE INTERIOR OF THE BASEMENT WALL.
  - FLOOR BASEMENT WALL - R-15 MIN. CONTINUOUS INSULATED SHEATHING ON THE INTERIOR OR EXTERIOR OF THE HOME; OR IF MORE THAN HALF OF THE INSULATION IS ON THE INTERIOR OF THE MASS WALL, R-19 MIN. CAVITY INSULATION AT THE INTERIOR OF THE BASEMENT WALL.
  - SLAB - R-10 MIN. @ 4" DEPTH. R-5 SHALL BE ADDED TO THE REQUIRED SLAB EDGE R-VALUES FOR HEATED SLABS.
  - CRAWL SPACE WALL - R-10 MIN. CONTINUOUS INSULATED SHEATHING ON THE INTERIOR OR EXTERIOR OF THE HOME OR R-13 CAVITY INSULATION AT THE INTERIOR OF THE BASEMENT WALL.
- THERMAL IMAGING TEST IS REQUIRED ONCE ALL INSULATION IS INSTALLED AND BEFORE DRYWALL OR OTHER WALL SURFACES ARE PLACED. TEST RESULTS SHALL BE SUBMITTED TO ARCHITECT FOR REVIEW.
- BLOWER DOOR TEST IS REQUIRED ONCE ALL DOORS AND WINDOWS ARE INSTALLED. TEST RESULTS SHALL BE SUBMITTED TO ARCHITECT FOR REVIEW. ACH50 TEST IS REQUIRED AND IS DEFINED AS THE NUMBER OF TIME THE AIR VOLUME IN A BUILDING CHANGES PER HOUR AT 50 PASCALS OF PRESSURE.
  - < 1.5 - VERY TIGHT (REQUIRES MECHANICAL VENTILATION)
  - 1.5 TO 3 - TIGHT (REQUIRES MECHANICAL VENTILATION)
  - 3 TO 6 - TYPICAL RANGE FOR NEW CONSTRUCTION (MAY REQUIRES MECHANICAL VENTILATION)
  - 6 TO 10 - LEAKY
  - 10 TO 20 - VERY LEAKY
- MECHANICAL CONTRACTOR TO SUBMIT MECHANICAL EQUIPMENT LAYOUTS TO ARCHITECT FOR APPROVAL PRIOR TO IMPLEMENTATION.
- THE REVIEW OF PLANS BY THE ARCHITECTURAL REVIEW COMMITTEE DOES NOT IMPLY THAT COMPLIANCE WITH FEDERAL, STATE AND LOCAL CODES HAS BEEN MET. IT IS THE RESPONSIBILITY OF THE APPLICANT TO ENSURE COMPLIANCE WITH ANY AND ALL LAWS GOVERNING THE DEVELOPMENT OF PROPERTY.
- G.C. SHALL SUBMIT WEEKLY DIGITAL PHOTOS OF THE PROJECT AT THE END OF EACH WEEK TO ARCHITECT & OWNER.
- G.C. SHALL SUBMIT TO ARCHITECT AND OWNER AND OPERATIONS AND MAINTENANCE INCLUDING BUT NOT LIMITED TO: TABLE OF CONTENTS, LIST OF CONTRACTORS AND SUB CONTRACTORS, SYSTEMS AND EQUIPMENT, AND EQUIPMENT AND OVERALL MAINTENANCE PROCEDURES.
- ALL PROPOSED ROOF PENETRATIONS SHALL BE COORDINATED BY GENERAL CONTRACTOR AND SUBMITTED TO ARCHITECT BEFORE INSTALLATION.
- CO DETECTORS SHOULD BE LOCATED OUTSIDE OF EACH SLEEPING AREA IN THE IMMEDIATE VICINITY OF THE BEDROOMS, AND ON EVERY LEVEL OF THE RESIDENCE, INCLUDING BASEMENTS AS APPLICABLE.
- A BENCH MARK OF 100" SHALL BE ESTABLISHED AT CONSTRUCTION SITE.
- HEADS OF SCREWS TO ALIGN VERTICALLY ON DOOR HARDWARE, ELECTRICAL OUTLET COVERS, ETC.
- PREVENT OR SIMILAR PRODUCT TO BE ADDED TO EXPOSED DUCT INTAKES IMMEDIATELY AFTER THEY ARE INSTALLED.
- IN WOOD FLOORING INSTALLATION OVER RADIANT HEAT, MODERATE SURFACE CHECKING, CRACKING, SHRINKAGE, GAPPING BETWEEN PLANKS, AND SLIGHT CUPPING ARE ALL TO BE EXPECTED AND DO NOT CONSTITUTE A PRODUCT DEFECT
- ALL DIFFUSERS TO BE FLUSH WITH WOOD FLOORS
- PRIOR TO PROJECT HAND OFF, ALL WATER SENSORS ARE TO BE TESTED

# MECHANICAL SPECIFICATIONS

- GENERAL WORKMANSHIP
- BIDSUBMITTALS
- DISCIPLINE COORDINATION
- MECHANICAL
- PLUMBING

# SITE MANAGEMENT NOTES

GENERAL NOTES

- BUILDING FOOTPRINT SHALL BE LOCATED BY A CERTIFIED SURVIVOR & TO BE REVIEWED AND APPROVED BY ARCHITECT BEFORE COMMENCING WORK.
- CONTRACTOR SHALL REMOVE ALL VEGETATION, TREES, STUMPS, DEBRIS AND EXISTING STRUCTURES, INCLUDING PAVEMENT, SIDEWALK, BUILDING FOUNDATION, ABANDONED UTILITIES AND EXISTING TOPSOIL IN ALL AREAS OF DEVELOPMENT.
- DO NOT DISTURB SITE BEYOND CONSTRUCTION LIMITS AS SET FORTH WITH THIS DRAWING SET.
- ALL SURFACES DISTURBED DURING CONSTRUCTION SHALL BE REPAIRED AND/OR RE-LANDSCAPED AS SET FORTH IN THE LANDSCAPING PLAN OR TO MATCH EXISTING WHERE NOT NOTED, SUCH THAT THEY BECOME INDISTINGUISHABLE FROM ADJACENT UNDISTURBED NATURAL AREAS.
- NOTICE TO ALL CONTRACTORS AND SUBCONTRACTORS: PROTECT NATURAL VEGETATION, TERRAIN, ROCKS, ETC. FROM STUCCO, PAINT, ROOFING FOAM, CONCRETE OR OTHER DAMAGE BY COVERING WITH PLASTIC OR AS REQUIRED. PROVIDE A 4'-0" HIGH BARRIER WITHIN BUILDING ENVELOPE (WHEN APPLICABLE). KEEP MATERIALS AND WORKMEN WITHIN THE FENCE TO PREVENT DAMAGE TO NATURAL TERRAIN AND VEGETATION. THE COST OF RECLAIMING OR REPAIRING ANY DAMAGE DUE TO NEGLIGENCE WILL BE AT THE CONTRACTOR'S/SUBCONTRACTOR'S EXPENSE.
- ANY AREAS EXTENDING BEYOND THE IMMEDIATE BUILDING SITE THAT ARE DISTURBED DURING CONSTRUCTION INCLUDING BUT NOT LIMITED TO, DRAINAGE FACILITIES AND UTILITY (SEWER, WATER, ELECTRIC, ETC.) TRENCHES SHALL BE RESTORED TO THEIR NATURAL STATE.
- ALL TRADES SHALL BE RESPONSIBLE TO COMPLETE SITE INVESTIGATION TO IDENTIFY SCOPE OF MATERIALS TO BE REMOVED AND NEW MATERIALS REQUIRED TO MATCH EXISTING CONSTRUCTION.
- ALL PROPERTY AND BUILDING LINES AS WELL AS ALL SLOP ELEVATIONS SUCH AS TOP OF PWD IN RELATION TO EXISTING GRADE, SHALL BE FIELD VERIFIED AND APPROVED BY ARCHITECT PRIOR TO CONSTRUCTION.
- HOUSE ADDRESS MARKING: A HOUSE NUMBER SHALL BE DISPLAYED IN A PROMINENT MANNER, SO THAT IT IS REASONABLY VISIBLE TO ENABLE EMERGENCY VEHICLES TO LOCATE THE RESIDENCE.
- ALL RETAINING WALLS TO HAVE DRAIN THE SUBSURROUND BY 3/4" CRUSHED GRAVEL WRAPPED IN GEOTEXTILE BEHIND WALL AND WEEPS @ 4'-0" O.C. (TYP). REFER TO SOils REPORT FOR FURTHER INFORMATION.
- 3"X4" NON-COMBUSTIBLE SPACE AROUND HOUSE PERIMETER IS REQUIRED 30'-0" DEFENSIBLE SPACE AROUND HOUSE PERIMETER IS STRONGLY RECOMMENDED.

### UTILITIES

- CONTRACTOR SHALL CONFIRM WITH EACH APPLICABLE AGENCY THAT ALL UTILITIES (SEWER, POWER, WATER, ETC.) ARE LOCATED AS SHOWN AND THAT SEWER TAP IS NOW ENOUGH TO SERVE ALL PLUMBING DRAINS.
- CONTRACTORS SHALL NOTIFY UTILITY LOCATOR A MINIMUM OF (3) WORKING DAYS PRIOR TO COMMENCING WORK TO DETERMINE HOW RESPECTIVE UTILITIES WILL BE EFFECTED BY CONSTRUCTION.
- UTILITIES ARE TO BE BURIED, AND SHALL COMPLY WITH ALL FEDERAL, STATE, AND LOCAL ORDINANCES.
- UTILITY ROUTING AND CONDUIT TRENCH LOCATIONS SHALL CONFORM TO ALL APPLICABLE BUILDING CODES WITH REFERENCE TO HORIZONTAL AND VERTICAL SEPARATION.
- ELECTRICAL METERS SHALL HAVE THE ABILITY TO BE READ REMOTELY BY POWER COMPANY.
- WATER SUPPLY LINE SHALL BE 1 1/2" OD POLYETHYLENE AND 8'-0" BELOW GRADE, UNLESS NOTED OTHERWISE.

### EXCAVATION

- ANY EXCAVATION SHALL BE CONDUCTED IN ACCORDANCE WITH RECOMMENDATIONS SET FORTH IN GEOTECHNICAL REPORT.
- FINISH GRADE SHALL BE A MINIMUM OF 6 INCHES BELOW WOOD FRAMING AT BUILDING EXTERIOR.
- FINISH GRADE TO SLOPE AWAY FROM STRUCTURE FOR A MINIMUM DISTANCE OF 10'-0" AND AT A MINIMUM SLOPE OF 1:10 AND A MAXIMUM SLOPE OF 1:2 UNLESS NOTED OTHERWISE. GEOTECHNICAL REPORT TO SUPERSEDE ANY FURTHER CONFLICTS.
- FINISH GRADE SHALL BE BURNED, AND SHALL COMPLY WITH ALL FEDERAL, STATE, AND LOCAL ORDINANCES.
- THE UNDER FLOOR GRADE SHALL BE CLEANED OF ALL VEGETATION AND ORGANIC MATERIAL. ALL WOOD FORMS USED FOR PLACING CONCRETE SHALL BE REMOVED, AND ALL CRAWL SPACES SHALL BE CLEANED OF ALL CONSTRUCTION DEBRIS BEFORE STRUCTURE IS OCCUPIED.

### FIRE SUPPRESSION

- FIRE SUPPRESSION SYSTEM IS REQUIRED. SPRINKLER SYSTEM DESIGN AND LAYOUT SHALL BE SUBMITTED TO ARCHITECT FOR REVIEW PRIOR TO COMMENCING INSTALLATION.
- FIRE SUPPRESSION ENGINEER OF RECORD SHALL BE CONTACTED BY GENERAL CONTRACTOR TO PERFORM ON-SITE OBSERVATION VERIFYING THE INSTALLATION IS IN ACCORDANCE WITH PLANS PROVIDED.

### STAGING NOTES

- THE CONTRACTOR IS RESPONSIBLE FOR OBTAINING FINAL APPROVAL FROM ANY APPLICABLE ARCHITECTURAL REVIEW COMMITTEE FOR ALL CONSTRUCTION STAGING IN THE FIELD PRIOR TO CONSTRUCTION.
- THE CONTRACTOR IS RESPONSIBLE FOR KEEPING ALL CLEARING AND EXCAVATION WITHIN EXISTING PROPERTY LINE BOUNDARIES AND GENERAL EASEMENTS.
- THE CONTRACTOR IS RESPONSIBLE FOR COORDINATING ANY REVISIONS OR ALTERATIONS TO THE CONSTRUCTION STAGING PLAN PRIOR TO CONSTRUCTION.
- THE CONTRACTOR TO INSTALL STRAW BALES IN ADDITION TO SILT FENCE AT LOCATIONS OF POTENTIAL RUN-OFF INTO WETLAND AREAS AS INDICATED ON SITE PLAN.
- ANY DAMAGE TO THE EXISTING ROADWAY, INCLUDING THE ASPHALT SURFACE, SHOULDER GRAVEL, ROADSIDE DITCH, EXISTING CULVERTS, AND EXISTING VEGETATION AND EROSION CONTROL MEASURES SHALL BE REPAIRED BY THE GENERAL CONTRACTOR TO THE SATISFACTION OF THE DEVELOPER.
- GRAVEL CONSTRUCTION ENTRANCE IS TO BE CONSTRUCTED WITH A MIN. OF 2" OF 3/4" SCREENED ROCK TO COVER ALL DRIVEWAYS, PARKING, AND LAY DOWN AREAS TO BE PLACED AT START OF CONSTRUCTION, AND A RECOMMENDATION OF A MIN. OF (8") MINUS 3" PITRUM OVER A GEOTECHNICAL SEPARATION FABRIC.
- ANY USE OF ANY FIRE HYDRANT IS PROHIBITED FOR USE BY ANY OTHER THAN THE GOVERNING FIRE DEPARTMENT.
- ALL WASTE SHALL BE CONTAINED ON SITE AND PROPERLY DISPOSED OF AT PROJECT COMPLETION. FURTHER, CONCRETE WASHOUT WITHIN THE ROADSIDE DITCHES IS STRICTLY PROHIBITED.
- GENERAL CONTRACTOR IS TO PROVIDE ONE LOCATION FOR CONCRETE TRUCK WASHOUT. CONCRETE WASHOUT WITHIN THE ROADSIDE DITCHES IS STRICTLY PROHIBITED.

# G.C. SUBMITTALS TO ARCHITECT

- DOCUMENT ALL EXISTING CONDITIONS AT CASBY RIDGE PRIOR TO STARTING CONSTRUCTION
- PROJECT SCHEDULE
- PROJECT BUDGET
- RADON MITIGATION PLAN AND DETAILS
- FIRE SUPPRESSION DESIGN AND LAYOUT, IF REQUIRED.
- MECHANICAL ROOM EQUIPMENT LAYOUT.
- ROOF PENETRATION PLAN.
- MATERIAL SAMPLES AND MOCKUPS AS REQUIRED - SEE MATERIAL LEGEND.
- STEEL SHOP DRAWINGS.
- TIMBER SHOP DRAWINGS.
- DOOR AND WINDOW MFR. SUBMITTALS AND SHOP DRAWINGS
- ROUGH OPENING WALK THROUGH REQUIRED. COORD. W/ ARCH.
- PRE-MANUFACTURED TRUSS SHOP DRAWINGS, AS APPLICABLE.
- VAPOR BARRIER SPECS AND SUBMITTAL SHEETS.
- INSULATION SPECS AND SUBMITTAL SHEETS.
- BELOW SLAB INSULATION WALK THROUGH, REVIEW, & APPROVAL REQUIRED. COORD. W/ ARCH.
- MECHANICAL DESIGN AND SHOP DRAWINGS WHERE MECHANICAL DESIGN IS NOT PROVIDED AS PART OF ARCHITECTS SCOPE.
- ELECTRICAL WALK THROUGH REQUIRED. COORD. W/ ARCH. OWNER
- SNOW GUARD AND GUTTER SUBMITTALS AND SHOP DRAWINGS.
- DOCUMENTATION OF SITE INSPECTIONS FROM STRUCTURAL ENGINEER AND GEOTECHNICAL ENGINEER AS OUTLINED BY EACH ENTITY.
- BLOWER DOOR TEST RESULTS
- THERMAL IMAGING TEST RESULTS (KEVIN BUD0: 406.581.3096)
- CONTRACT W/ RECYCLING COMPANY COORD. INFORMATION W/ ARCHITECT.
- OPERATIONS AND MAINTENANCE MANUAL.
- 3D HOUSE SCAN BY 3D BOZEMAN, LLC. SCAN TAKEN BEFORE DRYWALL IS INSTALLED. ANOTHER OPTIONAL SCAN AFTER HOUSE IS COMPLETED.
- WEEKLY OR BI-WEEKLY CONSTRUCTION REPORTS AND PHOTOS DESCRIBING ALL WORK PERFORMED, ANY BUDGET ITEMS, AND UP COMING SCHEDULE DEADLINES.
- UNDERGROUND UTILITIES RECORD DRAWINGS.
- TILE LAYOUT TO BE REVIEWED BY ARCHITECT OR ID.

### EROSION CONTROL AND BMP'S

- STORM WATER DETENTION POND(S) ARE REQUIRED TO MINIMIZE SEDIMENT RUNOFF. SEE SITE PLAN AND SITE DETAILS FOR FURTHER INFORMATION.
- STORM WATER DETENTION POND(S) SHOULD BE LOCATED ON SITE TO MAXIMIZE THE COLLECTION OF SURFACE RUNOFF WATER, IN ADDITION TO COLLECTING ROOF DRAINS AND DRAINAGE DRAIN IN ALL AREAS OF DEVELOPMENT.
- GENERAL CONTRACTOR SHALL INSTALL APPROPRIATE EROSION CONTROL FENCE AND/OR SEDIMENT STOP AS INDICATED ON SITE PLAN BEFORE START OF CONSTRUCTION.
- CONTRACTORS SHALL CONDUCT THEIR WORK IN SUCH A MANNER THAT ALL SOIL, FUELS, OILS, BITUMINOUS MATERIALS, CHEMICALS, SANITARY SEWAGE, AND OTHER HARMFUL MATERIALS ARE CONTAINED WITHIN THE PROJECT LIMITS AND PREVENTED FROM ENTERING STORMWATER COURSES, WATER COURSES, RIVERS, LAKES OR RESERVOIRS.
- THE CONTRACTOR SHALL PLACE A FILTER OR BARRIER COMPOSED OF STRAW, STONE, FILTER FABRIC, OR DRAINAGE STRUCTURE DEBRIS OR OTHER APPROVED MATERIAL AROUND ALL DRAINAGE COURSES TO PREVENT SEDIMENTATION IN THESE AREAS. AFTER THE CONSTRUCTION OPERATIONS ARE COMPLETED, THE CONTRACTOR SHALL REMOVE THESE FILTERS AND CLEAN ALL THE SEDIMENT AND GRATES FROM THE CATCH BASINS OR OTHER DRAINAGE STRUCTURES.
- THE COST OF THIS WORK AND OTHER CONTROL MEASURES, WHICH MAY BE REQUIRED, WILL NOT BE PAID FOR SEPARATELY, BUT SHALL BE CONSIDERED INCLUDED UNDER THE SCOPE OF THIS PROJECT.
- SEE DETAIL 121(A1-0.3) FOR RECOMMENDED SEDIMENT STOP INSTALLATION
- WATER DIVERTED FROM ITS ORIGINAL DRAINAGE PATTERN SHALL BE RETURNED TO ITS ORIGINAL COURSE BEFORE LEAVING THE PROPERTY.
- INTRODUCED DRAINAGE FEATURES SHALL BE NATURAL APPEARING, DESIGNED TO EMULATE INDIGENOUS SWALES AND WASHES AND SHALL CONFORM TO ALL DRAINAGE EASEMENTS.
- A "STORM WATER POLLUTION PROTECTION PLAN" (SWPPP) AND PERMIT IS REQUIRED FOR ANY PROJECT WHICH HAS ANY FORM OF DISTURBANCE IS GREATER THAN 1 ACRE. FURTHERMORE, THE GOVERNING DEVELOPMENT MAY REQUIRE A SWPPP REGARDLESS OF SIZE OF AREA OF DISTURBANCE.

### DRIVEWAY REQUIREMENTS

- ANY DRIVEWAY THAT SHALL SERVE AS A "FIRE LANE" AS INDICATED ON THE ARCHITECTURAL LOT DIAGRAM, SHEET A1-0.1, SHALL CONFORM TO THE FOLLOWING:
  - A. A YEAR ROUND DRIVABLE SURFACE CAPABLE TO SUSTAIN ANY IMPOSED LOADS OF FIRE APPARATUS (30 TONS).
  - B. AN UNSTRUCTURED DRIVABLE WIDTH OF NOT LESS THAN 18'-0" AND A MAXIMUM PAVED WIDTH OF 14'-0".
  - C. AN UNSTRUCTURED HEIGHT CLEARANCE OF NOT LESS THAN 13'-0".
  - D. A MAXIMUM SLOPE OF 12% AT ANY STRAIGHT RUN AND RECOMMENDED MAXIMUM SLOPE 05% AT ANY TURN LOCATION.
  - E. MINIMUM INSIDE TURNING RADIUS OF 30'-0", AND MINIMUM OUTSIDE TURNING RADIUS OF 50'-0".
- INSIDE TURNING RADIUS FOR ANY DRIVEWAY THAT IS NOT PART OF A "FIRE LANE" SHALL NOT BE LESS 10'.
- DRIVEWAY SHALL HAVE A NORMAL GRADE NOT TO EXCEED 10% EXCEPT FOR THE FIRST AND LAST 20' OF DRIVEWAY WHICH IS NOT TO EXCEED 4%.
- A MAXIMUM OF 5% GRADE IS STRONGLY RECOMMENDED AT ANY AND ALL TURNING LOCATIONS.
- SEE DETAILS FOR DRIVEWAY SECTION DETAILS

### LANDSCAPING

- LANDSCAPE CONTRACTOR SHALL REVIEW GEOTECHNICAL REPORT PRIOR TO INSTALLATION. COPIES OF REPORT AVAILABLE UPON REQUEST BY ARCHITECT/GENERAL CONTRACTOR.
- REFERENCE LANDSCAPE PLAN FOR ADDITIONAL LANDSCAPE NOTES.

### REMODEL - DUST CONTROL

- DUST CONTROL PLAN IS TO BE SUBMITTED TO OWNER AND ARCHITECT BEFORE DEMOLITION BEGINS.
- ISOLATE WORK AREA CLOSE DOORS AND SEAL OPENINGS NOT TO USE WITH TAPE.
- CREATE TEMPORARY WALLS AND CORDON OFF AREAS USING A ZIPWALL DUST BARRIER SYSTEM OR EQUAL TO THE MANUFACTURER'S SPECS.
- FLOOR PAPER SHOULD BE APPLIED TO ALL AREAS OF THE CONSTRUCTION ZONE.
- DESIGNATE ONE DOORWAY INTO THE STRUCTURE AND INSTALL A ZIPPOOR KIT OR EQUAL IN THAT ENTRY WAY SEPARATING WORK AREA FROM THE REST OF THE HOME. IT IS RECOMMENDED TO CHOOSE AN ENTRY WAY THAT ALSO HAS A DOOR TO CLOSE TO CREATE A DOUBLE BARRIER.
- DEMO WASTE TO BE REMOVED THROUGH A DUST BARRIER PROTECTION AREA, NOT THROUGH UNPROTECTED AREAS.
- IF POSSIBLE, COMPLETELY ELIMINATE ACCESS FROM INSIDE THE NON-CONSTRUCTION AREAS TO THE CONSTRUCTION AREAS; PROVIDING OUTDOOR OR ALTERNATIVE ACCESS TO REST ROOMS, OUTSIDE BASEMENT ACCESS TO UTILITIES, ETC.
- IT IS RECOMMENDED THAT STICKY MATS BE PLACED DIRECTLY OUTSIDE OF THE ENTRANCE TO THE CONSTRUCTION ZONE IN AN ATTEMPT TO CAPTURE EXTRA DUST FROM THE EXTERIOR.
- IT IS RECOMMENDED TO USE HIGH EFFICIENCY HEPA-FILTERED DUST CONTROL EQUIPMENT AND CONTAINMENT BARRIERS TO HELP ISOLATE AND REMOVE PARTICLES RELEASED INTO THE AIR DURING DEMOLITION.
- ESTABLISH A NEGATIVE PRESSURE ENVIRONMENT WITHIN THE WORKING DUCTWORK. KEEP WINDOWS AND DOORS INSIDE THE NON-REMODELLED HOME CLOSED AT ALL TIMES.
- TURN OFF DUCT WORK-BASED HEATING AND COOLING DURING THE ENTIRE CONSTRUCTION PROCESS. IT IS RECOMMENDED TO TAPE PLASTIC BARRIER OVER THE REGISTERS AND VENTS THROUGH OUT THE HOME.
- PRO-VENT OR SIMILAR PRODUCT TO BE ADDED TO EXPOSED DUCT INTAKES IMMEDIATELY AFTER THEY ARE INSTALLED.
- IT IS RECOMMENDED TO USE A HEPA VACUUM FOR CLEANING PURPOSES, NOT SWEEPING WITH A BROOM.
- EXISTING LIGHT FIXTURES TO REMAIN WALL BE SEALED OFF WITH PLASTIC AND TAPE.
- ONCE CARPET OR WOOD FLOORING IS REMOVED, MAKE SURE FLYWOOD SUBFLOOR IS SECURELY ATTACHED TO PREVENT SQUEAKS.
- IT IS RECOMMENDED TO PERFORM AS MUCH OF THE WORK OUTSIDE AS POSSIBLE.
- IT IS RECOMMENDED THAT ALL SMOKE ALARMS BE TAPED AND COVERED AFTER DEMO.

# STANDARD PUNCH LIST ITEMS

GC TO REVIEW AND COMPLETE ALL STANDARD PUNCH LIST ITEMS LISTED BELOW PRIOR TO FINAL PUNCH LIST WALKTHROUGH WITH ARCHITECT.

- BRING OPERATIONS & MAINTENANCE MANUAL - BINDER TO BE PROVIDED BY GC.
- CLEAN UP - GENERAL EXTERIOR AND INTERIOR CONSTRUCTION CLEAN UP
- CLEAN UP CONDITION
- REMOVE OR CLEAN UP PAINT - EXTERIOR AND INTERIOR PAINT SMEARED ON TRIM OR OTHER MATERIALS
- PUTTY - APPLY PUTTY TO ALL INTERIOR FINISH NAIL HOLES
- PAINT/STAIN - APPLY PAINT OR STAIN TO PUTTED NAIL HOLES OR WOOD THAT HAS BEEN CHIPPED
- STAIN - STAIN ALL WOOD FACES IF UNFINISHED
- SEALANT OR CAULK APPLIED WHERE APPLICABLE
- DRYWALL MUD & PAINT
- RECTIFY SCUFF
- REMOVE TAPE
- REMOVE EXISTING STRIKE FLAT BLACK THROUGHOUT
- CLEAN EXTERIOR THRESHOLDS
- ORIENTATE PLUMBING FUTURE HANDLES 90 DEGREES TO FLOOR OR COUNTER
- REMOVE LIGHT DUST & MATERIAL DROPPINGS FROM FLOOR BEFORE FAD & CARPET ARE ADDED
- WOOD FLOOR FILLER
- CLEAN WINDOW SASH
- CABINET DOOR BUMPERS APPLIED
- ALL DRAWERS TO BE ADJUSTED SO THERE IS NO MOVEMENT AND NO RUBBING
- PAINT FLOOR MECHANICAL VENTS FLAT BLACK
- CLEAN ALL VENTS OF ANY CONSTRUCTION DEBRIS

# MOISTURE CONTROL

- SLOPE PATIO SLABS, WALLS AND DRIVEWAYS A MINIMUM OF 1/8" PER FT. AWAY FROM U.N.N. TAMP BACK FILL IN 6" LAYERS TO PREVENT SETTLING, AN SLOPE THE FINAL GRADE AWAY FROM THE FOUNDATION AT A RATE AS SPECIFIED BY THE GEOTECHNICAL ENGINEER.
- INSTALL PROTECTED DRAIN TILE AT FOOTINGS. PER SITE SPECIFIC GEOTECHNICAL REPORT. DISCHARGE TO OUTSIDE GRADE (DAYLIGHT) OR TO A SUMP PUMP. NO SURFACE OR ROOF DRAINAGE SHALL BE ROUTED TO ANY PART OF THE FOOTING DRAIN TILE SYSTEM.
- DRAINS OR SUMP PUMPS IN BASEMENT AND CRAWL SPACE FLOORS TO DISCHARGE A MIN. OF 10 FT. OUTSIDE THE FOUNDATION OR ON TO AN APPROVED SEWER SYSTEM. PROVIDE SEALED GASKET SUMP PUMP COVER IN AREAS WHERE RADON IS OF CONCERN.
- PROTECT CAPILLARY BREAKS BENEATH CONCRETE SLABS, INCLUDING BASEMENT FLOORS.
- DAMP PROOF OR WATER PROOF ALL EXTERIOR SURFACES OF BELOW-GRADE FOUNDATION WALLS.
- DIRECT ROOF WATER AWAY FROM THE STRUCTURE USING GUTTERS AND DOWNSPOUTS THAT EMPTY INTO LATERAL PIPING THAT DEPOSITS WATER ON A SLOPING FINISHED GRADE A MINIMUM OF 30 FT. FROM THE FOUNDATION. ROOFS DESIGNED WITHOUT GUTTERS ARE ACCEPTABLE IF THEY ARE DESIGNED TO DEPOSIT RAINWATER TO A GRADE-LEVEL ROCK BED WITH WATERPROOF URN DRAIN PIPE THAT DEPOSITS WATER ON A SLOPING FINISHED GRADE, AS SPECIFIED ABOVE. WHEN LOT SPACE LIMITS OR PREVENTS REQUIRED GRADING, DIRECT ROOF WATER TO AN UNDERGROUND CATCHMENT SYSTEM (NOT CONNECTED TO THE FOUNDATION DRAIN TILE SYSTEM) THAT DEPOSITS WATER A MINIMUM OF 30 FT. FROM THE FOUNDATION. RAINWATER HARVESTING SYSTEMS MAY BE USED TO MEET THIS REQUIREMENT WHEN THEY ARE DESIGNED TO PREVENT DRAIN OVERFLOW, MEETING DISCHARGE DISTANCE REQUIREMENTS ABOVE.
- INSTALL MOISTURE-RESISTANT MATERIAL AND MOISTURE PROTECTIVE SYSTEMS IN VULNERABLE AREAS TO PREVENT THE GROWTH OF MOLD. INSTALL WATER-RESISTANT HARD-SURFACE FLOORING IN KITCHENS, BATHROOMS, ENTRYWAYS, LAUNDRY AREA & UTILITY ROOMS. DO NOT INSTALL WALL-TO-WALL CARPET ADJACENT TO TOILETS AND BATHING FIXTURES.
- INSTALL MOISTURE-RESISTANT EXTERIOR WALLS. CONSIDER THE EQUIVALENT, BUT NOT PAPER-FACED WALL BOARD BEHIND TUB AND SHOWER ENCLOSURES.
- INSTALL ALL CONDENSATE DISCHARGE ACCORDING TO SECTION M141.3.
- INSULATE FINISH INSTALLED EXTERIOR WALLS.
- DO NOT INSTALL CONTINUOUS VAPOR BARRIERS ON THE INTERIOR SIDE OF EXTERIOR WALLS THAT HAVE A CONDENSATION POTENTIAL (E.G., BELOW-GRADE EXTERIOR WALLS IN MOST CLIMATES AND ABOVE-GRADE EXTERIOR WALLS IN HUMID CLIMATES). EXAMPLE: AN INTERIOR STUD WALL ERRECTED NEXT TO A BELOW-GRADE BASEMENT WALL AND INSULATED WITH MINERAL WOOL, FIBERGLASS OR CELLULOSE INSULATION SHOULD NOT HAVE FOIL-FACED PAPER, POLYETHYLENE FILM OR PLASTIC BARRIER ON ITS INTERIOR SURFACE. WATER VAPOR PASSING FROM THE DAMP PART THROUGH THE BELOW-GRADE CONCRETE OR CMU WALL WILL PASS EASILY THROUGH THE INSULATION MATERIALS, BUT ACCUMULATE ON MICROCLIMATE USING MATERIALS OF 2 PERMS OF MORE ON THE INTERIOR OF THE WALLS ALLOWING IT TO DRY INTO THE BASEMENT.
- DO NOT INSTALL BUILDING MATERIALS THAT HAVE VISIBLE SIGNS OF WATER DAMAGE OR MOLD. IN ADDITION, INTERIOR WALLS SHALL NOT BE ENCLOSED (E.G., WITH DRYWALL) IF EITHER THE FRAMING MEMBERS OR INSULATION HAS A HIGH MOISTURE CONTENT. FOR WET-APPLIED INSULATION, FOLLOW THE MANUFACTURER'S DRYING RECOMMENDATIONS. HUMIDITY SHOULD NOT EXCEED 10% MOISTURE CONTENT.
- GARAGE FLOOR DRAINS ARE TO MEET DISCHARGE DISTANCE REQUIREMENTS ABOVE AND TO DRAIN INTO LANDSCAPED/VEGETATED HOLDINGS POUNDS TO ALLOW WASTE WATER TO NATURALLY EVAPORATE. SEE SWPPP # 18A REQUIREMENTS.

# GEOTECHNICAL REPORT NOTES

NOTES REGARDING THE GEOTECHNICAL REPORT PROVIDED HERE ARE IN NO WAY INTENDED TO SERVE AS A SUPPLEMENT TO THE GEOTECHNICAL REPORT. IT IS REQUIRED THAT THE GENERAL CONTRACTOR AS WELL AS ANY APPLICABLE SUB CONTRACTORS REVIEW AND REVIEW THE GEOTECHNICAL REPORT. IN ITS ENTIRETY AND TO NOTIFY THE GEOTECHNICAL ENGINEER IF THERE ARE ANY QUESTIONS OR CONCERNS.

A FULL GEOTECHNICAL ANALYSIS AND REPORT HAS BEEN PREPARED FOR THIS PROPERTY BY: TRAUTNER GEOTECH

- SURFACE & SUBSURFACE DRAINAGE SHALL CONFORM TO THE GEOTECHNICAL ENGINEER'S RECOMMENDATIONS AS SET FORTH IN THE REFERENCED GEOTECHNICAL REPORT.
- PROPER DRAINAGE SHOULD BE PROVIDED IN THE FINAL DESIGN AND DURING CONSTRUCTION. THE ARCHITECT SHALL BE NOTIFIED OF ANY ISSUES OR CONFLICTS NOT ACCOUNTED FOR WITHIN THESE DRAWINGS OR THE REFERENCED GEOTECHNICAL REPORT.
- SITE PREPARATION PROCEDURES AND FOUNDATION EXCAVATIONS TO BE OBSERVED BY THE GEOTECHNICAL ENGINEER TO ASSURE THAT THE ADEQUATE BEARING CONDITIONS EXIST AND THAT PLACEMENT OF ENGINEERED FILL HAS BEEN PERFORMED SATISFACTORILY. IF THE SOIL CONDITIONS ENCOUNTERED DIFFER SIGNIFICANTLY FROM THOSE PRESENTED IN THE GEOTECHNICAL REPORT, SUPPLEMENTAL RECOMMENDATIONS MAY BE REQUIRED.
- POSITIVE DRAINAGE SHALL BE PROVIDED DURING CONSTRUCTION AND MAINTAINED THROUGHOUT THE LIFE OF THE PROPOSED DEVELOPMENT. INFILTRATION OF WATER INTO UTILITIES OR FOUNDATION EXCAVATIONS MUST BE PREVENTED DURING CONSTRUCTION.
- STRIP AND REMOVE ANY EXISTING VEGETATION, ORGANIC TOPSOILS, DEBRIS AND ANY OTHER DELETTERIOUS MATERIALS FROM THE BUILDING AREAS. THE BUILDING AREAS ARE DEFINED AS THAT AREA WITHIN THE BUILDING FOOTPRINT PLUS 5 FEET BEYOND THE PERIMETER OF THE FOOTPRINT. ALL EXPOSED SURFACES SHOULD BE FREE OF MOUNDS AND DEPRESSIONS THAT COULD PREVENT UNIFORM COMPACTION.
- FROZEN SOILS SHOULD NOT BE USED AS FILL OR BACKFILL.
- EXISTING SOILS REMOVED AT BUILDING FOOTPRINT EXCAVATION MAY BE REUSED IN LANDSCAPE AREAS, AS LONG AS IN ACCORDANCE OF THE REFERENCED GEOTECHNICAL REPORT.
- ALL IMPORT FILL AND ON-SITE BACKFILLS SHOULD BE APPROVED BY THE GEOTECHNICAL ENGINEER. WHERE FILL IS TO BE PLACED, LOOSE OR OTHERWISE UNSUITABLE MATERIAL SHOULD BE REMOVED PRIOR TO PLACEMENT OF NEW FILL.
- GEOTECHNICAL ENGINEER OF RECORD SHALL BE CONTACTED BY THE GENERAL CONTRACTOR AT THE ONSET OF THE PROJECT TO SCHEDULE AND PERFORM ON-SITE REVIEWS AT THE GEOTECHNICAL ENGINEERS DISCRETION THROUGH ANY AND ALL STAGES OF EXCAVATION AND FOUNDATION.
- ALL EXCAVATION WORK SHALL CONFORM TO OSHA REGULATIONS.

# RECYCLING

AT A MINIMUM THE FOLLOWING EXCESS MATERIALS TO BE RECYCLED: CARDBOARD, DRYWALL, WOOD, METAL, COPPER, BRASS, STEEL, TIN, NEWSPAPER, AND CARDBOARD

THE FOLLOWING RECYCLING CONTRACTORS ARE TO BE CONSIDERED:

- FULL CYCLE RECYCLE BS GALLATIN GATEWAY, MONTANA 59730 (406) 370-5561 DAVE - (406) 570-5561
- L&L SITE SERVICES (406) 599-0601 CELL LANCE - (406) 581-0509 CELL
- RESOURCE SITE SERVICES (406) 581-3551 www.resourceiteservices.com
- PACIFIC STEEL & RECYCLING (406) 587-0662 www.pacific-steel.com CONTACT: ROB SHACLEFORD

# RADON SYSTEMS

NOTE: RADON PLAN TO BE SUBMITTED BY CONTRACTOR, TO ARCHITECT FOR REVIEW. RADON MEASURED IN PICO CURIES PER LITER (pCi/L)

- 4 pCi/L - ACTION REQUIRED LEVEL
- 2 pCi/L - ACCEPTABLE LEVEL
- >2pCi/L - RADON LEVEL GOAL

### RADON MITIGATION - CRAWL SPACE POSITIVE SUB-MEMBRANE DEPRESSURIZATION SYSTEM

- FOUNDATION WALL - ALL CONTROL JOINTS, ISOLATION JOINTS & OTHER JOINTS SHOULD BE CAULKED WITH AN ELECTROMETRIC SEALANT SUCH AS POLYURETHANE CAULK, DAMP PROOF FOUNDATION WALL AND SEAL ANY PENETRATIONS THROUGH THE WALL.
- CRAWLSPACE SHEETING TO BE HIGH-DENSITY CROSS-LAMINATED POLYETHYLENE. COLOR TO BE WHITE. OVERLAY W/ EPDM RUBBERIZED ROOFING MEMBRANE AT HIGH TRAFFIC AREAS.
- INSTALL PROTECTED DRAIN TILE AT FOOTINGS. PER SITE SPECIFIC GEOTECHNICAL REPORT. DISCHARGE TO OUTSIDE GRADE (DAYLIGHT) OR TO A SUMP PUMP. NO SURFACE OR ROOF DRAINAGE SHALL BE ROUTED TO ANY PART OF THE FOOTING DRAIN TILE SYSTEM.
- DRAINS OR SUMP PUMPS IN BASEMENT AND CRAWL SPACE FLOORS TO DISCHARGE A MIN. OF 10 FT. OUTSIDE THE FOUNDATION OR ON TO AN APPROVED SEWER SYSTEM. PROVIDE SEALED GASKET SUMP PUMP COVER IN AREAS WHERE RADON IS OF CONCERN.
- PROTECT CAPILLARY BREAKS BENEATH CONCRETE SLABS, INCLUDING BASEMENT FLOORS.
- DAMP PROOF OR WATER PROOF ALL EXTERIOR SURFACES OF BELOW-GRADE FOUNDATION WALLS.
- DIRECT ROOF WATER AWAY FROM THE STRUCTURE USING GUTTERS AND DOWNSPOUTS THAT EMPTY INTO LATERAL PIPING THAT DEPOSITS WATER ON A SLOPING FINISHED GRADE A MINIMUM OF 30 FT. FROM THE FOUNDATION. ROOFS DESIGNED WITHOUT GUTTERS ARE ACCEPTABLE IF THEY ARE DESIGNED TO DEPOSIT RAINWATER TO A GRADE-LEVEL ROCK BED WITH WATERPROOF URN DRAIN PIPE THAT DEPOSITS WATER ON A SLOPING FINISHED GRADE, AS SPECIFIED ABOVE. WHEN LOT SPACE LIMITS OR PREVENTS REQUIRED GRADING, DIRECT ROOF WATER TO AN UNDERGROUND CATCHMENT SYSTEM (NOT CONNECTED TO THE FOUNDATION DRAIN TILE SYSTEM) THAT DEPOSITS WATER A MINIMUM OF 30 FT. FROM THE FOUNDATION. RAINWATER HARVESTING SYSTEMS MAY BE USED TO MEET THIS REQUIREMENT WHEN THEY ARE DESIGNED TO PREVENT DRAIN OVERFLOW, MEETING DISCHARGE DISTANCE REQUIREMENTS ABOVE.
- INSTALL MOISTURE-RESISTANT MATERIAL AND MOISTURE PROTECTIVE SYSTEMS IN VULNERABLE AREAS TO PREVENT THE GROWTH OF MOLD. INSTALL WATER-RESISTANT HARD-SURFACE FLOORING IN KITCHENS, BATHROOMS, ENTRYWAYS, LAUNDRY AREA & UTILITY ROOMS. DO NOT INSTALL WALL-TO-WALL CARPET ADJACENT TO TOILETS AND BATHING FIXTURES.
- INSTALL MOISTURE-RESISTANT EXTERIOR WALLS. CONSIDER THE EQUIVALENT, BUT NOT PAPER-FACED WALL BOARD BEHIND TUB AND SHOWER ENCLOSURES.
- INSTALL ALL CONDENSATE DISCHARGE ACCORDING TO SECTION M141.3.
- INSULATE FINISH INSTALLED EXTERIOR WALLS.
- DO NOT INSTALL CONTINUOUS VAPOR BARRIERS ON THE INTERIOR SIDE OF EXTERIOR WALLS THAT HAVE A CONDENSATION POTENTIAL (E.G., BELOW-GRADE EXTERIOR WALLS IN MOST CLIMATES AND ABOVE-GRADE EXTERIOR WALLS IN HUMID CLIMATES). EXAMPLE: AN INTERIOR STUD WALL ERRECTED NEXT TO A BELOW-GRADE BASEMENT WALL AND INSULATED WITH MINERAL WOOL, FIBERGLASS OR CELLULOSE INSULATION SHOULD NOT HAVE FOIL-FACED PAPER, POLYETHYLENE FILM OR PLASTIC BARRIER ON ITS INTERIOR SURFACE. WATER VAPOR PASSING FROM THE DAMP PART THROUGH THE BELOW-GRADE CONCRETE OR CMU WALL WILL PASS EASILY THROUGH THE INSULATION MATERIALS, BUT ACCUMULATE ON MICROCLIMATE USING MATERIALS OF 2 PERMS OF MORE ON THE INTERIOR OF THE WALLS ALLOWING IT TO DRY INTO THE BASEMENT.
- DO NOT INSTALL BUILDING MATERIALS THAT HAVE VISIBLE SIGNS OF WATER DAMAGE OR MOLD. IN ADDITION, INTERIOR WALLS SHALL NOT BE ENCLOSED (E.G., WITH DRYWALL) IF EITHER THE FRAMING MEMBERS OR INSULATION HAS A HIGH MOISTURE CONTENT. FOR WET-APPLIED INSULATION, FOLLOW THE MANUFACTURER'S DRYING RECOMMENDATIONS. HUMIDITY SHOULD NOT EXCEED 10% MOISTURE CONTENT.
- GARAGE FLOOR DRAINS ARE TO MEET DISCHARGE DISTANCE REQUIREMENTS ABOVE AND TO DRAIN INTO LANDSCAPED/VEGETATED HOLDINGS POUNDS TO ALLOW WASTE WATER TO NATURALLY EVAPORATE. SEE SWPPP # 18A REQUIREMENTS.

### RADON MITIGATION - ACTIVE SUB-SLAB SYSTEM

- PLACE A UNIFORM LAYER OF CLEAN AGGREGATE UNDER ALL CONCRETE SLABS OF FLOOR SYSTEMS THAT DIRECTLY CONTACT THE GROUND AND ARE WITHIN THE WALLS OF THE LIVING SPACES. USE A MINIMUM OF 1" THICK LAYER 1/2" TO 3/4" IN SIZE. UNLESS GEOTECHNICAL RECOMMENDATIONS ARE MORE STRINGENT.
- PLACE A "T" FITTING AT THE LOCATION THE RISER WILL EXTEND THROUGH THE SLAB. CONCRET SHORT STUD, AT LEAST 8" X 4" PVC, BE VERTICALLY INTO THE TEE. LAY 4" PERFORATED AND CORRUGATED PIPE (MINIMUM LENGTH OF 10 FEET) IN THE GRAVEL AND CONNECT IT TO THE RADON VENT RISER TEE FITTING. AN ELBOW FITTING MAY BE USED IN PLACE OF A TEE FITTING WHEN USING ADDITIONAL PIPING IN THE FLOOR. MAKE SURE THE CONCRETE DOES NOT RENT UP THE PIPE DURING POUR.
- PRIOR TO POURING THE SLAB OR PLACING FLOOR ASSEMBLY, LAY A MIN. 6-MIL OR 3-MIL CROSS LAMINATED POLYETHYLENE OR EQUIVALENT SHEETING MATERIAL ON TOP OF THE GAS PERMEABLE LAYERS. THE SHEETING SHOULD COVER THE ENTIRE FLOOR AREA. SHEETING SHOULD FIT CLOSELY AROUND ANY PIPE, WIRE OR PENETRATIONS.
- FOUNDATION WALL AND SLABS SHOULD BE CONSTRUCTED TO REDUCE POTENTIAL RADON ENTRY ROUTES. IN GENERAL, OPENINGS IN WALL AND SLABS SHOULD BE MINIMIZED AND NECESSARY OPENINGS AND JOINTS SHOULD BE SEALED.
- ALL CONTROL JOINTS OR OTHER JOINTS SHOULD BE SEALED WITH POLYURETHANE CAULK TO REDUCE RADON ENTRY.
- LABEL RISER AT ALL VISIBLE LOCATIONS SO IT IS NOT CONFUSED WITH ANY OTHER PLUMBING. LABEL PLASTIC SHEETING TO STATE THAT THE PLASTIC SHOULD NOT BE REMOVED AND, IF CUT, IT SHOULD BE PATCHED OR REPLACED. AFTER CONSTRUCTION IS COMPLETED, INSPECT THE SHEETING FOR DAMAGE AND REPAIR AS NECESSARY.
- PROVIDE FOR FUTURE FAN IF NEEDED. FAN CANNOT BE INSIDE THE LIVING SPACE OR CRAWLSPACE. FANS ARE MOST OFTEN LOCATED

## MATERIAL SPECIFICATIONS

### EXTERIOR MATERIALS LEGEND

**NOTE:**  
REFER TO PROJECT SPECIFICATIONS FOR FURTHER INFORMATION ON MATERIAL TYPES AND INSTALLATION REQUIREMENTS.

	<b>METAL ROOFING</b> STANDING SEAM, 2" MECH. RIB WITH STRIATIONS & MASTIC, 36" RIB SPACING COLOR: SLATE GREY RAWWIDE MFR: TBD
	<b>BALLAST ROOFING</b> EPDM ROOF WITH RIVER ROCK BALLAST COLOR: GREY MIX
	<b>HORIZONTAL WOOD SIDING</b> 2x10 RECLAIMED WOOD BOARD RAINSCREEN, HORIZONTAL WITH 1" SPACING COLOR: VARIOUS GREY MFR: MRL RE: 1/ AS-1.2
	<b>STONE MASONRY VENEER</b> NATURAL RECTANGULAR CUT DEEP CREEK 1 1/2" VENEER LAYOUT: RE: 2/ AS-1.2
	<b>STEEL SIDING</b> PATINATED STEEL SIDING PANELS, 1/8" W/EXPOSED FASTENERS, SEE ELEVATIONS FOR SEAM SPACING PATINA: VARIOUS BROWN/BLACK MFR: TBD RE: 3/ AS-1.2

### EXTERIOR MATERIAL QUANTITIES

MATERIAL	ELEVATION (SF/%)				TOTAL
	NORTH	EAST	SOUTH	WEST	
STONE	1180/28.9	946/42.1	211/17.4	852/57.8	3,189/25.4
METAL	507/11.4	431/19	496/36.8	90/6.1	1,522/16.9
WOOD	467/11.4	434/19.3	203/25	371/25.2	1,475/16.4
FENESTRATION	1929/47.2	441/19.6	302/40.1	161/10.9	2,833/31.4

### CEILING MATERIALS LEGEND

**NOTE:**  
REFER TO PROJECT SPECIFICATIONS FOR FURTHER INFORMATION ON MATERIALS AND INSTALLATION REQUIREMENTS.

	<b>CEILING FINISH - PAINT</b> 5/8" GWB TYPE "X" WITH PAINTED FINISH REFERENCE INTERIOR FINISH SPECIFICATIONS FOR COLOR, (TYP.)
	<b>CEILING FINISH - WOOD</b> RECLAIMED WOOD BOARDS STAIN: TBD MFR: VINTAGE RE:
	<b>CEILING FINISH - TILE</b> COORDINATE TYPE AND LAYOUT WITH ID, (TYP.)
	<b>CEILING FINISH - CEILOTEX TILE</b> 24" X 24" RE: MFR FOR SPECIFICATIONS

### ALL SAMPLES TO BE SUBMITTED TO ARCHITECT

NOTE: AFTER 54 METAL SIDING SAMPLE IS SUBMITTED AND APPROVED, RECONFORM METAL ROOF, FLASHING, GUTTER AND D.S. FINISH W/ ARCH.

## MATERIAL BOARD



R1



R2

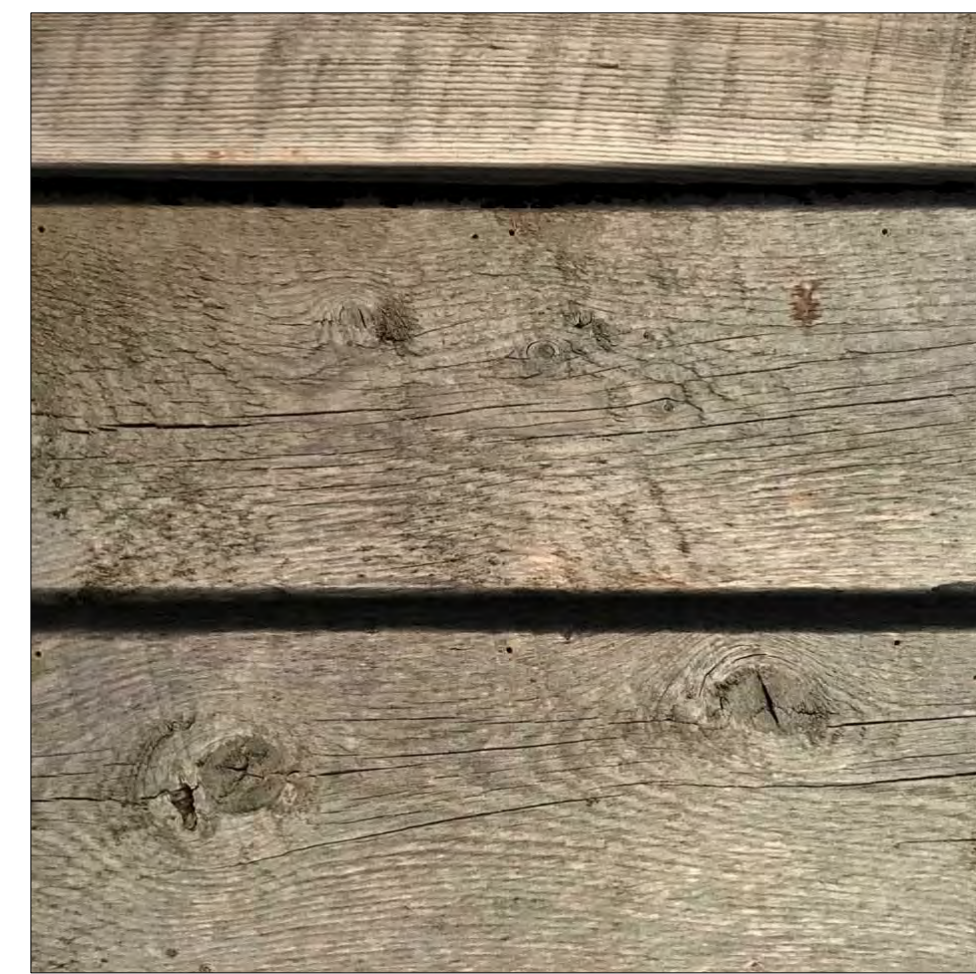

S1



S2

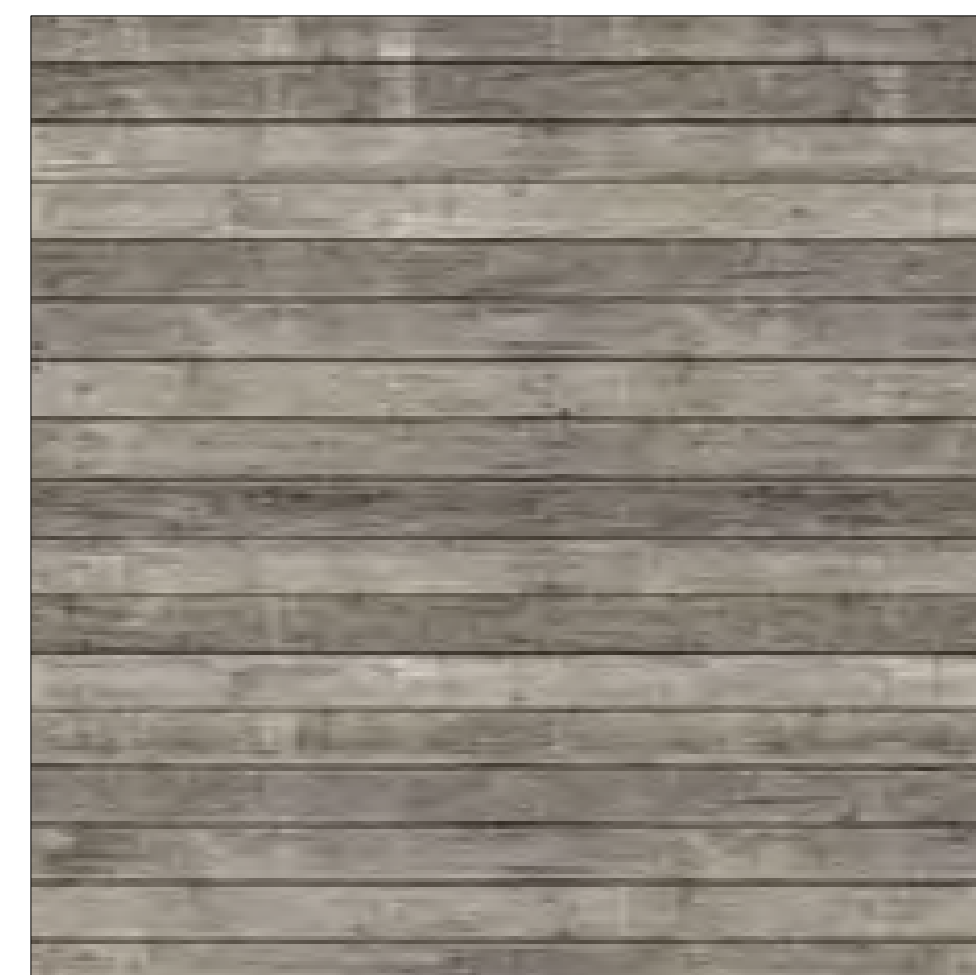

C2

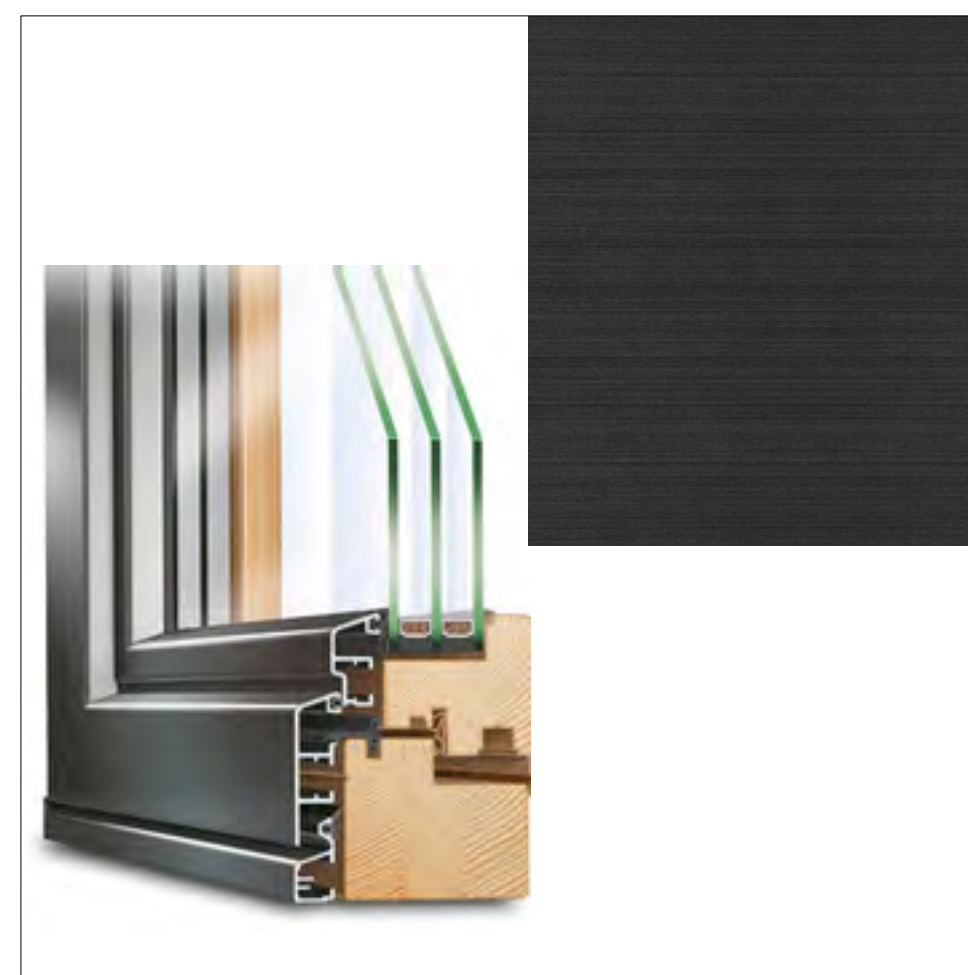

TBD

CONTEMPORARY PROFILE, CLEAR PINE INTERIOR, BLACK EXTERIOR

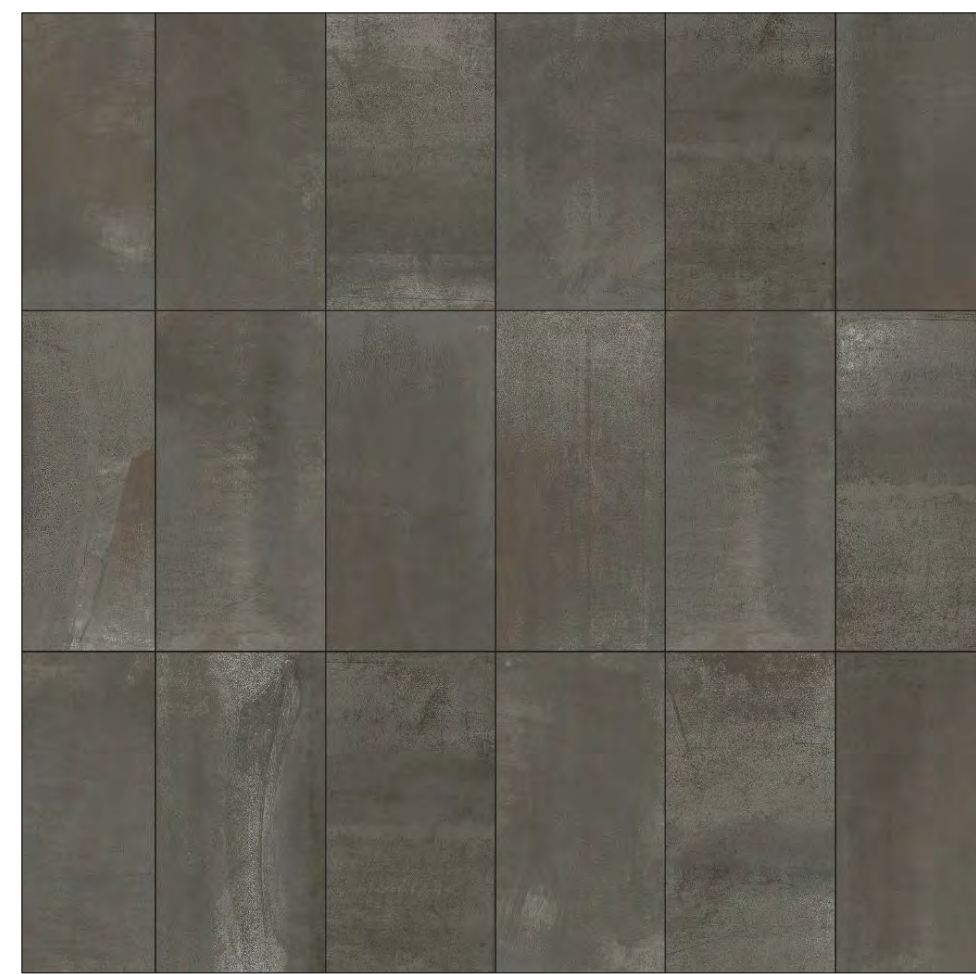

S3

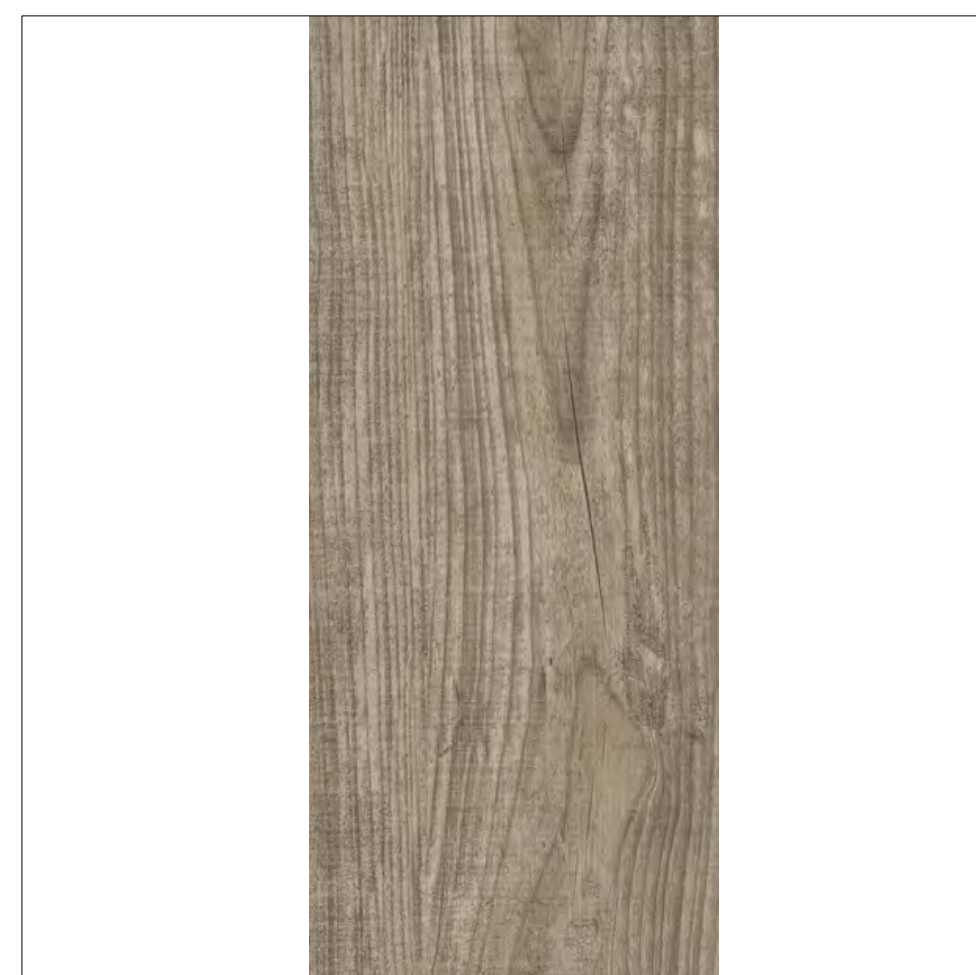

TIMBERS



STONE TYPE D  
EXTERIOR BOULDERS

## MATERIAL TYPE SCHEDULE

SCHEDULE						
METAL	APPLICATION	MFR.	SPECIES/TYPE	TEXTURE	COLOR/FINISH	COMMENTS
TYPE 'A'	FLASHING	BRIGGS STEEL	-	PRE-FINISHED	-	MATCH R1 ROOF FINISH
TYPE 'B'	EXPOSED STRUCTURAL STEEL	T.B.D.	PER STRUCTURAL	-	PAINTED	-
TYPE 'C'	DECORATIVE	T.B.D.	-	T.B.D.	PATINA	GC TO SUBMIT SAMPLES TO MATCH PROVIDED IMAGES - RAW STEEL W/ PENETROL OR SIM. COAT
TYPE 'D'	WALL PANELING	T.B.D.	-	T.B.D.	PATINA	-
<b>WOOD</b>						
TYPE 'A'	TIMBER BEAMS & POSTS	T.B.D.	NEW DOUGLAS FIR	WIRE BRUSHED	STAINED	-
TYPE 'B'	FASCIA	T.B.D.	CEDAR	WIRE BRUSHED	STAINED	-
TYPE 'C'	EXTERIOR TRIM	T.B.D.	CEDAR	WIRE BRUSHED	STAINED	-
TYPE 'D'	INTERIOR TRIM	T.B.D.	SPRUCE	SMOOTH	T.B.D.	-
<b>STONE</b>						
TYPE 'A'	PRIMARY WALL VENEER	QUARRY WORKS	DEEP CREEK	T.B.D.	T.B.D.	-
TYPE 'B'	CAP STONE	QUARRY WORKS	DEEP CREEK	T.B.D.	T.B.D.	-
TYPE 'C'	EXTERIOR PATIO FLAGSTONE	T.B.D.	T.B.D.	T.B.D.	T.B.D.	-
TYPE 'D'	EXTERIOR BOULDERS	QUARRY WORKS	DEEP CREEK	T.B.D.	T.B.D.	-

**NOTE:**  
• ALL CUT ENDS, MITERS, & CORNERS TO BE SEALED W/ MFR RECOMMENDED SEALANT/STAIN  
• COORD. W/ MFR FOR ADDITIONAL TOUCH UP STAIN  
• COORD. W/ MFR ON TOUCH UP APPLICATIONS AND TREATMENTS

## INSULATION SPECIFICATIONS

INSULATION SCHEDULE - PROJECT SPECIFIC				
CAVITY	R - VALUE		MINIMUM	PROJECT SPECIFIC
	MINIMUM	PROJECT SPECIFIC		
ROOFS OVER HEATED SPACES	R-49	R-51	8.5"	MIN OF SPRAY APPLIED POLYURETHANE INSULATION
EXTERIOR WALLS	R-20	R-24	4"	MIN. OF SPRAY APPLIED POLYURETHANE INSULATION
INTERIOR WALLS	-	R-15	RECOMMENDED 4"	BLOWN IN CELLULOSE - DAMP SPRAYED OR EQUIVALENT ROCK WOOL BATT INSULATION
FLOORS OVER UNHEATED SPACES	R-30	R-36	6"	MIN. OF SPRAY APPLIED POLYURETHANE INSULATION
FLOORS OVER HEATED SPACES	-	-	3.5"	MINERAL FIBER BATT INSULATION IN FLOORS OVER HEATED SPACES FOR SOUND INSULATION
BASEMENT WALL	R-15/19	R-19	R-19 BATT	INSULATION - WHERE STUD BAY EXISTS 3.5"-2" POLYURETHANE TAPER ELSEWHERE
CRAWL SPACE	LD WALL	R-20	R-24	4" SPRAY POLYURETHANE INSULATION OR EQ.
	WALL	R-15/19	R-21	3.5" SPRAY POLYURETHANE
UNDER CONC. SLAB	-	R-10/13	R-14	2" OF DOW STYROFOAM BRAND SM <sup>SM</sup> INSULATION

**NOTES:**  
1. ARCHITECT'S RECOMMENDATION FOR ALL EXTERIOR EAVES AND RAKES TO RECEIVE MIN. OF 3" BLOWN IN POLYURETHANE INSULATION UNLESS NOTED OTHERWISE.  
2. DEDUCT ALTERNATE AS APPROVED BY ARCHITECT TO REPLACE 4" SPRAY APPLIED POLYURETHANE INSULATION AT EXTERIOR WALLS WITH AN R-11 MINERAL FIBER BATT OVER TOP OF 2" SPRAY APPLIED POLYURETHANE INSULATION.  
3. ARCHITECT'S RECOMMENDATION FOR BASEMENT FURRING WALLS TO RECEIVE 3.5" BLOWN IN POLYURETHANE INSULATION IN PLACE OF R-19 BATT.  
4. DEDUCT ALTERNATE AS APPROVED BY ARCHITECT TO REPLACE 2" NCF SPRAY APPLIED POLYURETHANE INSULATION UNDER CONCRETE SLAB WITH 2" POLY-ISOCYANURATE RIGID FOAM INSULATION.  
5. GENERAL CONTRACTOR TO PROVIDE COST COMPARISONS FOR BLOWN-IN WET CELLULOSE PRODUCT TO REPLACE BATT INSULATION IN EXTERIOR WALLS AND FLOORS.  
6. THERMAL IMAGING TEST SHALL BE PERFORMED AND REPORT SUBMITTED TO OWNER AND ARCHITECT.  
7. AT A MINIMUM, ALL INTERIOR WALLS SEPARATING BEDROOMS AND/OR BATHROOMS SHALL BE INSULATED AS SPECIFIED ABOVE. IT IS STRONGLY RECOMMENDED THAT ALL INTERIOR WALLS BE INSULATED.  
8. FOAM INSULATING SEALANT AT ALL WINDOWS AND DOORS.  
9. INSULATION REQUIRED AT ALL HEADERS UNLESS HEADER FILLS CAVITY

## AV SYSTEMS

ENVIRONMENTAL SECURITY	YES
WATER - LOW TEMP/FREEZE -	YES
WATER COP -	YES
HUMIDITY -	YES
SECURITY LIFE SAFETY & INTRUSION	YES
CO -	YES
HEAT -	YES
SMOKE -	YES
GAS -	YES
DOORS -	-
MOTION -	-
SIRENS & STROBE -	-
SPRINKLER -	YES
SEPTIC ALARM -	YES
ACCESS CONTROL -	-
SECURITY CAMERAS -	YES
HOME AUTOMATION -	-
BUILT - IN SPEAKERS -	YES
TV/DISPLAYS -	YES
GAMING SYSTEM -	YES
THEATER/MEDIA RM -	-
EXTERIOR AUDIO/VIDEO	-
LIGHTING CONTROL -	YES
AUTOMATED SHADES -	YES
CEILING INTEGRATED -	-
WALL INTEGRATED -	-
SURFACE MOUNT -	-
NETWORK / DATA SYSTEM -	YES
GARAGE DOOR AUTOMATIC CLOSE TIMER -	YES

## HVAC SYSTEMS

FORCED AIR HEATING SYSTEM -	-
RADIANT HEAT -	-
HEAT RECOVERY VENTILATION SYSTEM -	-
SOLAR HOT WATER -	-
GEOTHERMAL SYSTEM -	-
WATER FILTRATION -	-
WATER COP -	-
WATER SOFTENER -	-
REVERSE OSMOSIS -	-
OXYGEN -	-
BACK UP GENERATOR -	-
T.B.D. -	-
BACK UP BATTERY	-
ACTIVE RADON MITIGATION -	YES
PROPANE -	-
SNOW MELT -	-

## PLUMBING SPEC.

TOILET	HEATED	YES/NO
	WALL MOUNTED	YES/NO
	SELF CLEANING	YES/NO
	BIDET	YES/NO
<b>MECH. CHECKLIST</b>		
FURNACE	-	-
HUMIDIFIER (IF REQ. BY OWNER)	-	-
CRAWLSPACE EXHAUST FAN	-	-
PROPANE DETECTION SYSTEM	-	-
GARAGE EXHAUST FAN	-	-
BATHROOM EXHAUST FAN	-	-
KITCHEN EXHAUST FAN	-	-
RADON EXHAUST FANS (IF REQ. BY RADON TEST)	-	-
KITCHEN MAKE UP AIR SYSTEM	-	-
GARAGE UNIT HEATER	-	-
WATER HEATER	-	-
DOMESTIC HOT WATER RECIRCULATION PUMP	-	-
ENERGY RECOVERY VENTILATOR	-	-

## MECH. CHECKLIST

## CENTRE SKY ARCHITECTURE, LTD. ARCHITECTURE & PLANNING

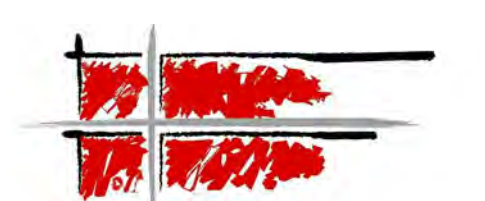

**COLORADO:**  
10125 RANCHO MONTECITO  
DR. PARKER, COLORADO 80138  
P 303.840.0020

**MONTANA:**  
P.O. BOX 161488  
11 LONE PEAK DR., UNIT 206  
BIG SKY, MONTANA 59716  
P 406.995.7572

**UTAH:**  
1960 SIDEWINDER DR., #101  
PARK CITY, UTAH 84060  
P 435.604.0891

www.centresky.com

TELLURIDE #6  
TELLURIDE, CO 81435

NOT FOR  
CONSTRUCTION



Issued For \_\_\_\_\_ Date \_\_\_\_\_  
• 100% S.D. 01/14/2021  
• Pricing # \_\_\_\_\_  
• ARC Sketch Review 01/14/2021  
• 100% D.D. \_\_\_\_\_  
• ARC Final Review \_\_\_\_\_  
• 100% C.D. \_\_\_\_\_  
• REV. # \_\_\_\_\_

Drawn By S. D'AGOSTINO  
Date 01/14/2021  
Project # 2021.00  
Phase SD  
Sheet

A0-0.2  
MATERIAL  
SPECIFICATIONS



COLORADO:  
10125 RANCHO MONTECITO  
DR. PARKER, COLORADO 80138  
P 303.840.0020

MONTANA:  
P.O. BOX 161488  
11 LONE PEAK DR., UNIT 206  
BIG SKY, MONTANA 59716  
P 406.995.7572

UTAH:  
1960 SIDEWINDER DR., #101  
PARK CITY, UTAH 84060  
P 435.604.0891

www.centresky.com

TELLURIDE #6  
TELLURIDE, CO 81435

NOT FOR  
CONSTRUCTION



Issued For \_\_\_\_\_ Date \_\_\_\_\_  
• 100% S.D. 01/14/2021  
• Pricing # \_\_\_\_\_  
• ARC Sketch Review 01/14/2021  
• 100% D.D. \_\_\_\_\_  
• ARC Final Review \_\_\_\_\_  
• 100% C.D. \_\_\_\_\_  
• REV. # \_\_\_\_\_

Drawn By S. D'AGOSTINO  
Date 01/14/2021  
Project # 2021.00  
Phase SD  
Sheet

A0-0.3  
AREA PLANS

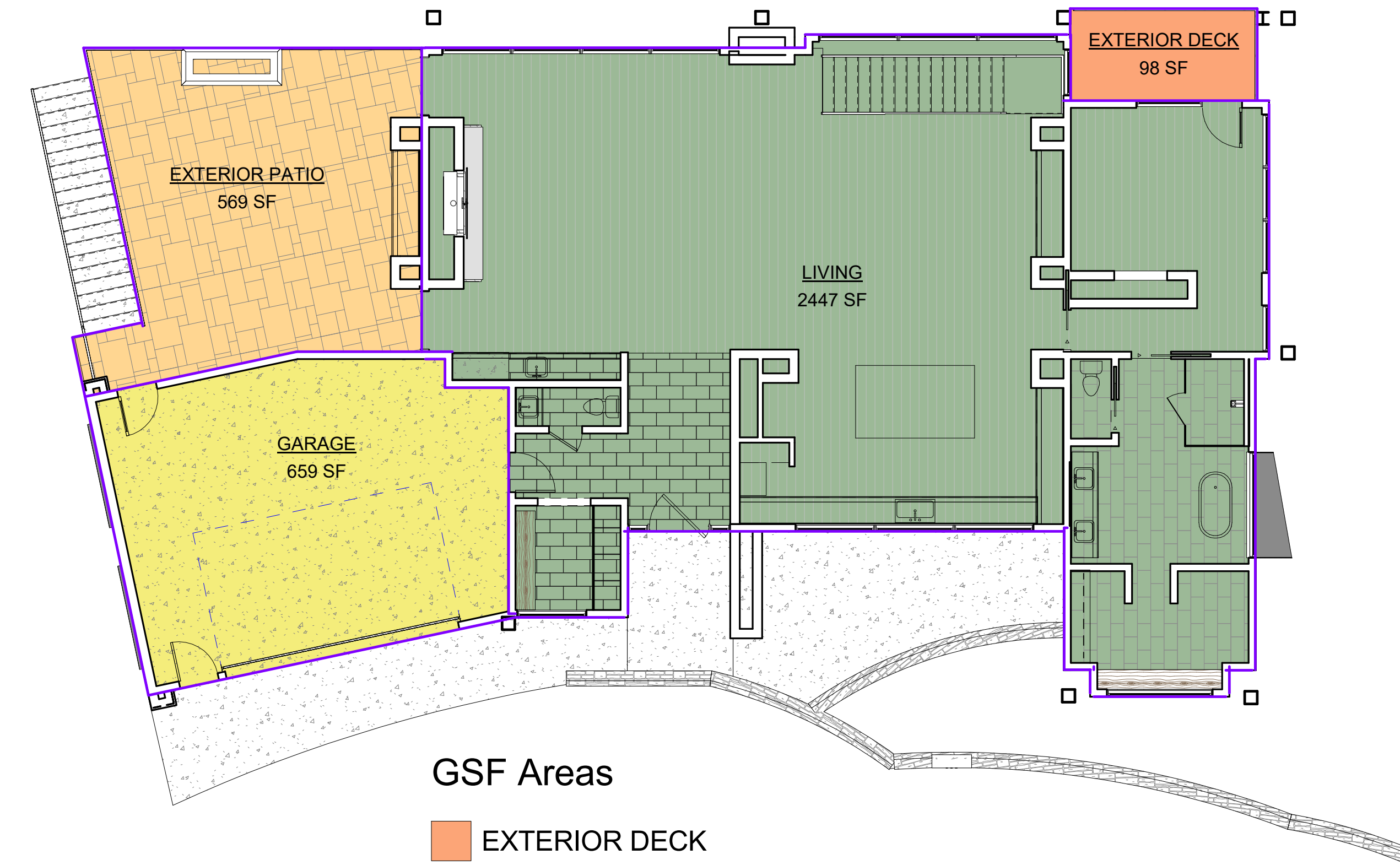

GSF Areas

- EXTERIOR DECK
- EXTERIOR PATIO
- GARAGE
- LIVING

2 T.O. SUB FLR  
1/8" = 1'-0"

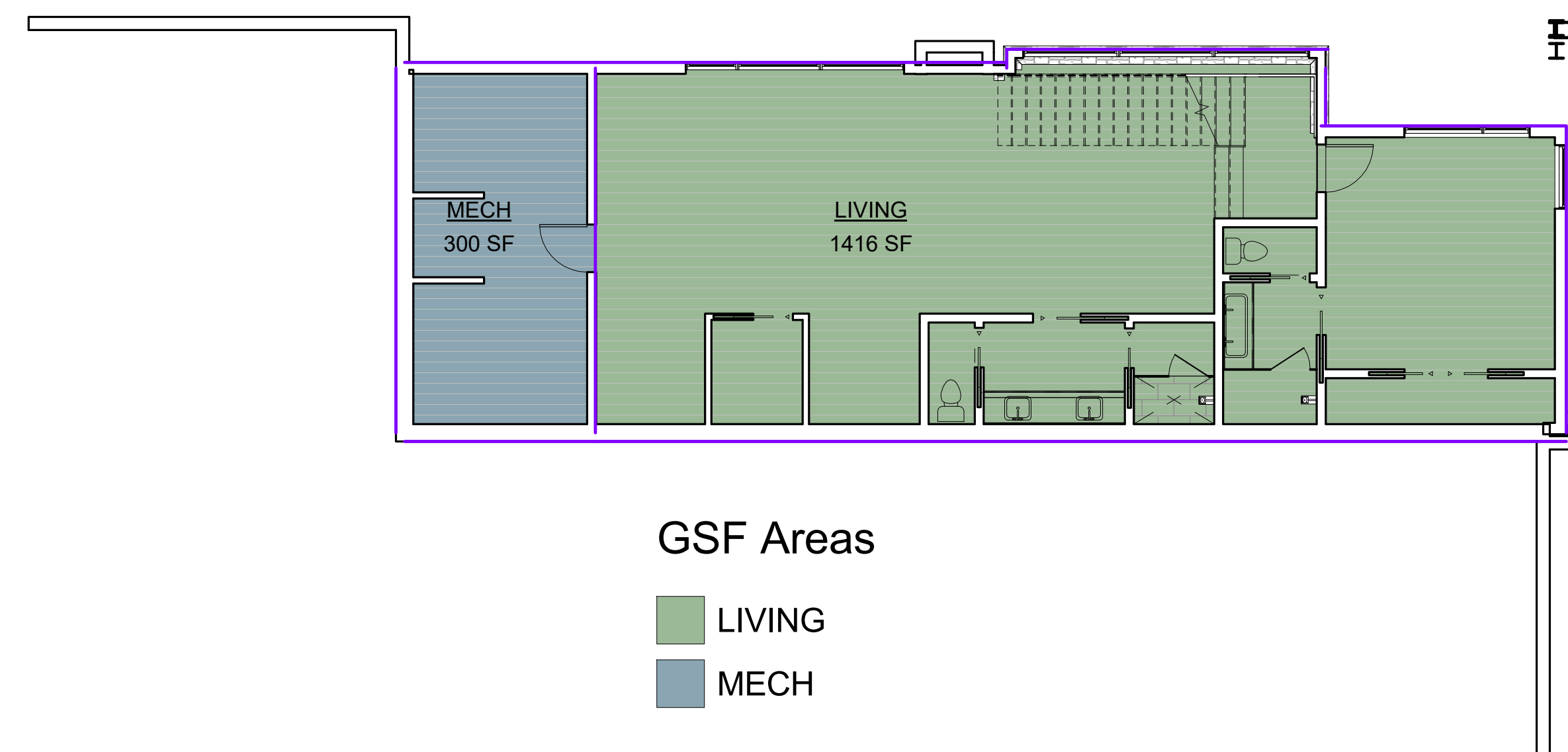

GSF Areas

- LIVING
- MECH

4 T.O. ROCK BOTTOM  
1/8" = 1'-0"

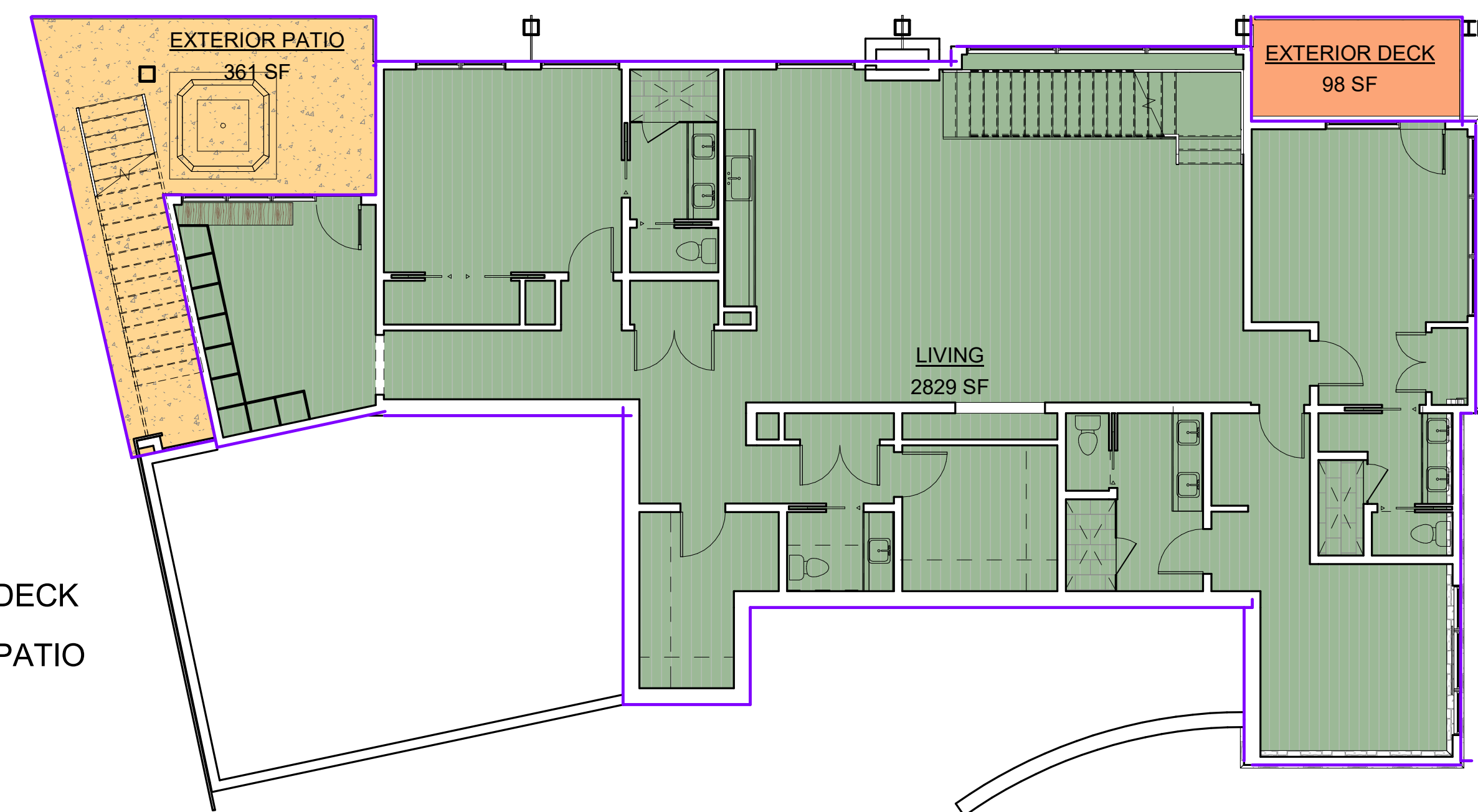

GSF Areas

- EXTERIOR DECK
- EXTERIOR PATIO
- LIVING

3 T.O. SLAB  
1/8" = 1'-0"

AREA ANALYSIS

**DEFINITIONS:**  
**SQUARE FOOT:** LIVABLE FLOOR AREA AS MEASURED FROM EXTERIOR FACE OF STUD OR FACE OF CONCRETE WALL, INCLUDING THICKNESS OF ALL WALLS, INTERIOR AND EXTERIOR (EXCLUDING EXTERIOR FINISHES); DOES NOT INCLUDE FIREPLACE BUMP-OUTS, MECHANICAL SPACES, GARAGE SPACES, AND UNFINISHED BASEMENT AND/OR ATTIC SPACE.  
**GROSS SQUARE FOOT:** TOTAL BUILDING AREA AS MEASURED FROM EXTERIOR DIMENSIONS INCLUDING THICKNESS OF ALL WALLS, INTERIOR AND EXTERIOR (EXCLUDING EXTERIOR FINISHES), MECHANICAL SPACES, GARAGE SPACES, AND ACCESSIBLE UNFINISHED SPACE; DOES NOT INCLUDE CRAWL SPACES, PATIOS AND DECKS.

PROJECT SQUARE FOOTAGE		
LEVEL	NAME	AREA
T.O. ROCK BOTTOM	LIVING	1416 SF
T.O. SLAB	LIVING	2829 SF
T.O. SUB FLR	LIVING	2447 SF
HABITABLE		6692 SF
T.O. ROCK BOTTOM	MECH	300 SF
T.O. SUB FLR	GARAGE	659 SF
NON HABITABLE		958 SF
GROSS AREA		7651 SF

EXTERIOR SQUARE FOOTAGE		
Level	NAME	AREA
T.O. SLAB	EXTERIOR DECK	98 SF
T.O. SLAB	EXTERIOR PATIO	361 SF
T.O. SUB FLR	EXTERIOR DECK	98 SF
T.O. SUB FLR	EXTERIOR PATIO	569 SF
TOTAL EXTERIOR		1126 SF

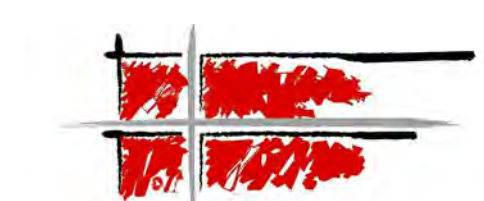

**COLORADO:**  
10125 RANCHO MONTECITO  
DR. PARKER, COLORADO 80138  
P.303.840.0020

**MONTANA:**  
P.O. BOX 161488  
11 LONE PEAK DR., UNIT 206  
BIG SKY, MONTANA 59716  
P.406.995.7572

**UTAH:**  
1960 SIDEWINDER DR., #101  
PARK CITY, UTAH 84060  
P.435.604.0891

www.centresky.com

TELLURIDE #6  
TELLURIDE, CO 81435

NOT FOR  
CONSTRUCTION



Issued For	Date
• 100% S.D.	01/14/2021
• Pricing #	-
• ARC Sketch Review	01/14/2021
• 100% D.D.	-
• ARC Final Review	-
• 100% C.D.	-
• REV. #	-

Drawn By S. D'AGOSTINO  
Date 01/14/2021  
Project # 2021.00  
Phase SD  
Sheet

**C1-0.0**  
SURVEY

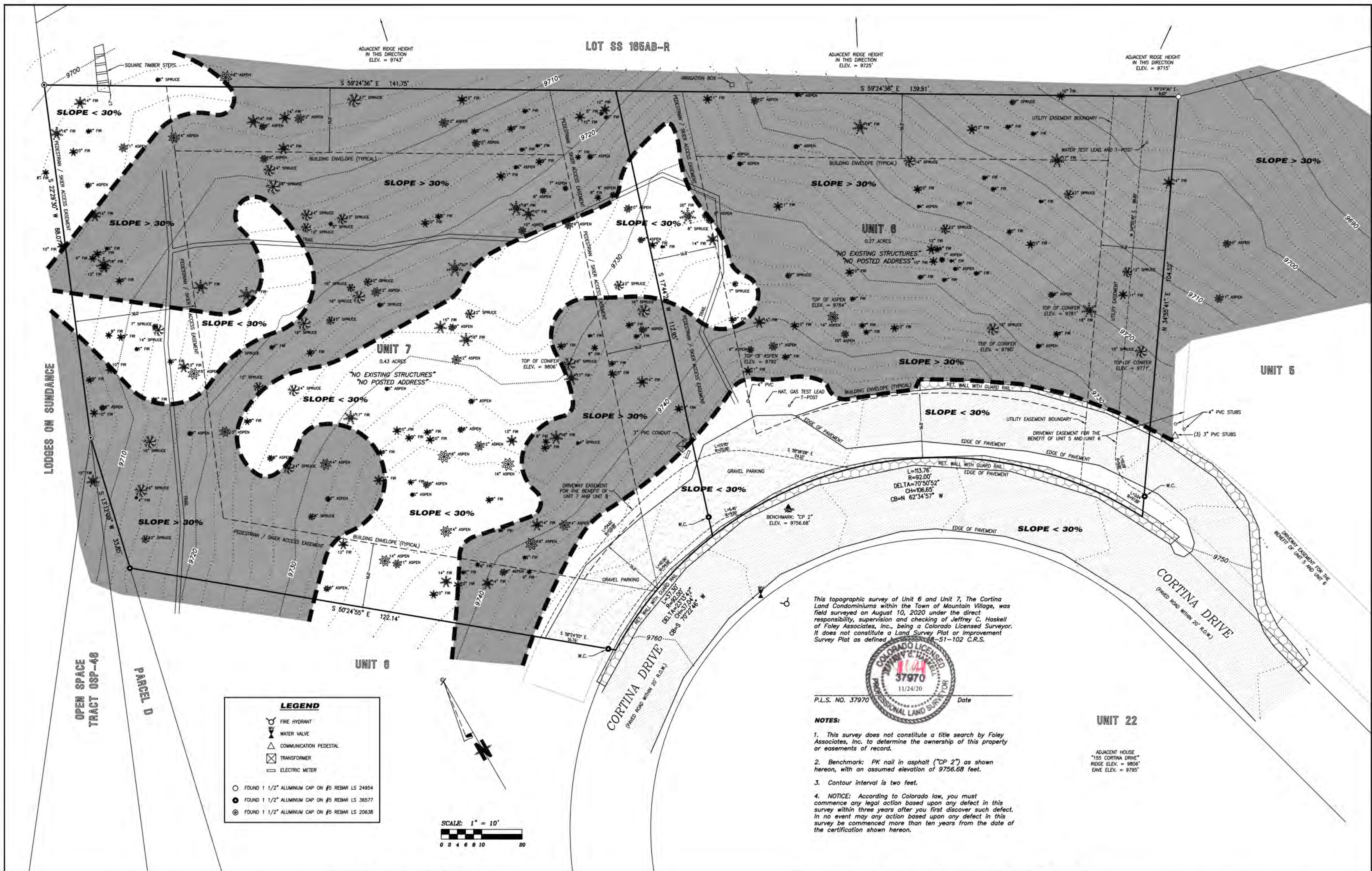

**TOPOGRAPHIC SURVEY**  
**Unit 6 and Unit 7, The Cortina Land Condominiums, Town of Mountain Village**  
Located within Section 3, T. 42 N., R. 9 W., N.M.P.M., San Miguel County, Colorado

Project Mgr:	JH
Technician:	FO
Checked by:	PC
Start date:	08 / 2020



970-728-6153 970-728-6050 fax  
P.O. BOX 1385  
125 W. PACIFIC, SUITE B-1  
TELLURIDE, COLORADO 81435

Drawing path: d:\2025 Topo 08-20.dwg Sheet 1 of 1 Project #: 20025

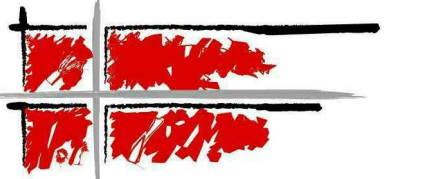

COLORADO:  
10125 RANCHO MONTECITO  
DR. PARKER, COLORADO 80138  
P 303.840.0020

MONTANA:  
P.O. BOX 16488  
11 LONE PEAK DR., UNIT 206  
BIG SKY, MONTANA 59716  
P 406.995.7572

UTAH:  
1960 SIDEWINDER DR., #101  
PARK CITY, UTAH 84060  
P 435.604.0891

www.centresky.com



ALPINE LAND  
CONSULTING, LLC  
P.O. BOX 234  
RICO, COLORADO 81352  
970-708-0326  
GREG@ALPINELANDCONSULTING.COM

TELLURIDE #6  
TELLURIDE, CO 81435

NOT FOR  
CONSTRUCTION

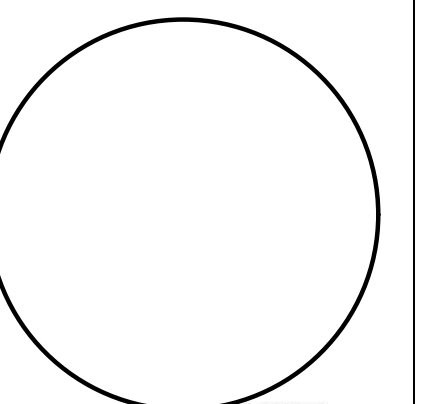

Issued For	Date
• 100% S.D.	1/13/2021
• Pricing #	
• ARC Sketch Review	1/13/2021
• 100% D.D.	
• ARC Final Review	
• 100% C.D.	
• REV. #	

Drawn By S. D'AGOSTINO  
Date 1/13/2021  
Project # 2021.00  
Phase SD  
Sheet

C1-0.1  
DRB GRADING

NOTES

- THIS IS A PLANNING DOCUMENT ONLY AND NOT TO BE USED FOR CONSTRUCTION.
- MAXIMUM GRADING 2.5:1. ANY SLOPES GREATER THAN 2.5:1 ARE SHOWN AS THEY HAVE TO CONNECT INTO EXISTING STEEPER SLOPES AND TO BE CONFIRMED BY GEOTECHNICAL ENGINEER PRIOR TO FINAL CONSTRUCTION DOCUMENTS.
- ALL EXISTING BOUNDARY AND TOPOGRAPHIC INFORMATION PROVIDED BY FOLEY ASSOCIATES INC. DATED 08/2020 WITH A BENCHMARK BEING PK NAIL IN ASPHALT ('CP 2') WITH ASSUMED ELEVATION OF 9756.68 FEET. CONTACT JEFF HASKELL AT (970) 728-6153 FOR MORE BENCHMARK INFORMATION.
- ALL RETAINING WALL HEIGHTS AREA FINISHED GRADE TO FINISHED GRADE (RETAINED HEIGHT) AND DO NOT INCLUDE FOUNDATIONS OR CAPS.
- RETAINING WALLS WITH PEDESTRIAN ACCESS REQUIRE HARD RAILS FOR ALL RETAINED HEIGHT OVER 2.5' (SEE ARCHITECTURAL, STRUCTURAL, AND/OR LANDSCAPE PLANS).
- NO DETENTION PROPOSED AS THIS SITE IS PART OF CONDOMINIUM SUBDIVISION AND HAS EXISTING DRAINAGE FACILITIES.

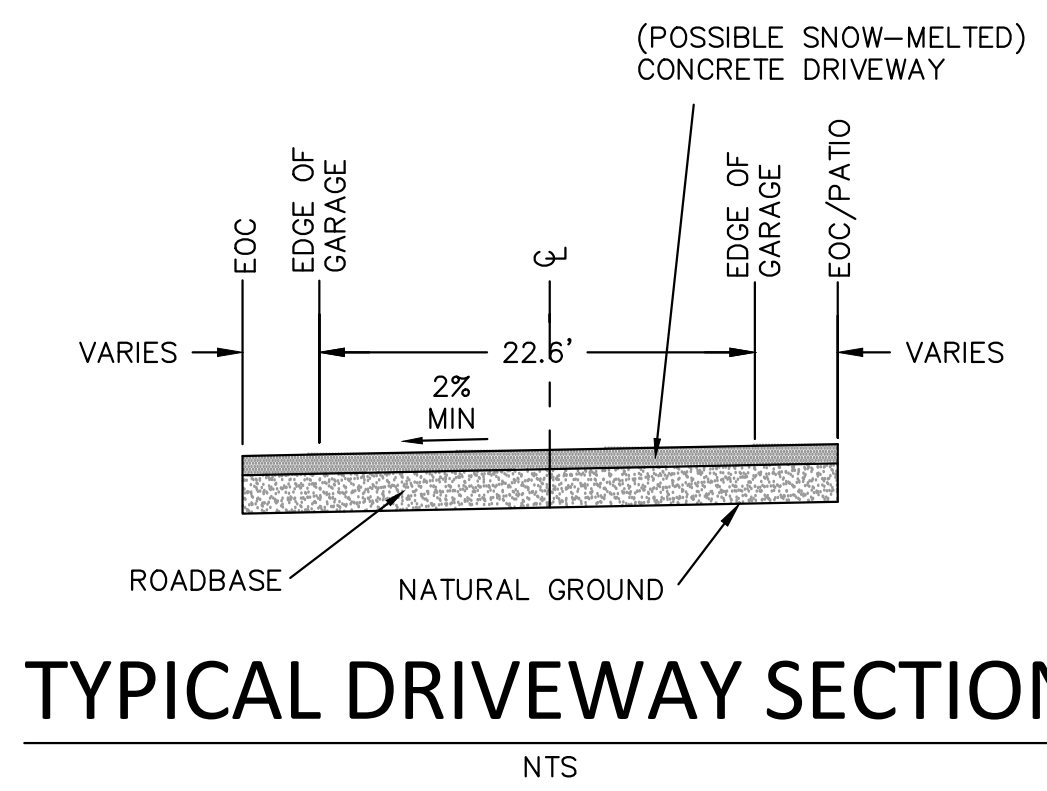

TYPICAL DRIVEWAY SECTION

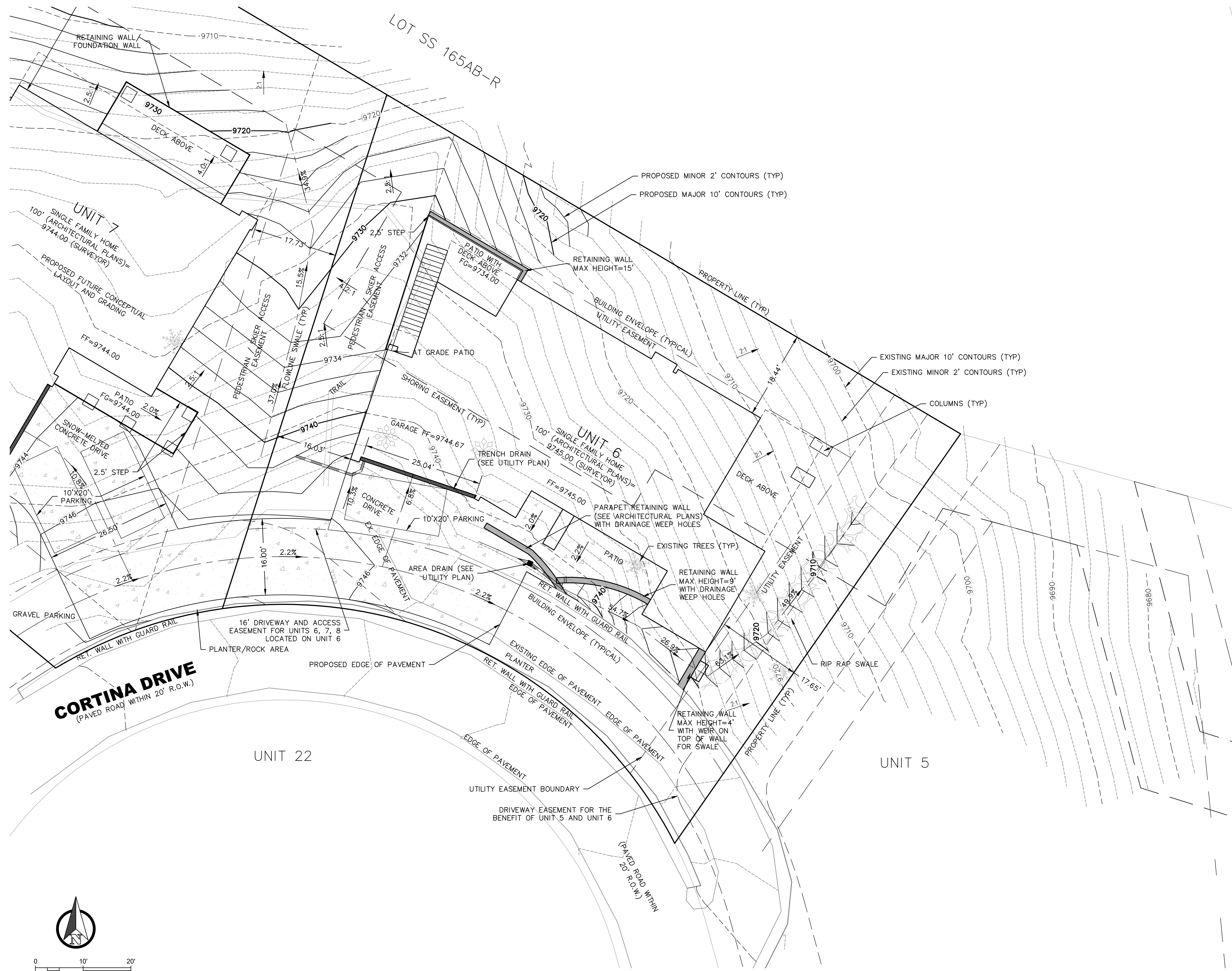

FOR DRB ONLY AND NOT  
FOR CONSTRUCTION

CALL UTILITY NOTIFICATION  
CENTER OF COLORADO  
**1-800-922-1987**  
OR  
**811**  
CALL 2-BUSINESS DAYS IN ADVANCE  
BEFORE YOU DIG, GRADE, OR  
EXCAVATE FOR THE MARKING OF  
UNDERGROUND MEMBER UTILITIES.

THESE PLANNING DRB DOCUMENTS WERE PREPARED BY ME AND UNDER MY DIRECT SUPERVISION ON BEHALF OF ALPINE LAND CONSULTING, LLC FOR SILVER GLADE DEVELOPMENT COMPANY AND INCLUDES PRELIMINARY DRB PLANNING DESIGN ONLY, AND DOES NOT INCLUDE ANY OTHER PLANNING OR ENGINEERING.

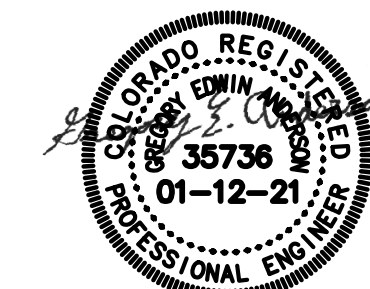

GREGORY E. ANDERSON  
COLORADO PROFESSIONAL ENGINEER  
REGISTRATION NO. 35736

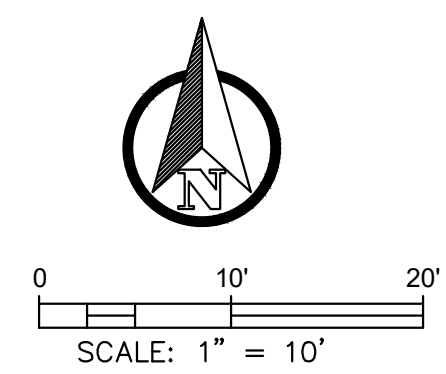

DRB GRADING PLAN

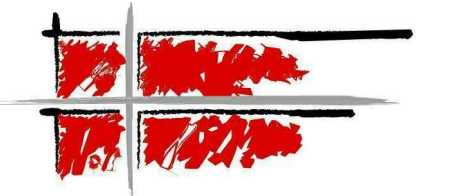

**COLORADO:**  
 10125 RANCHO MONTECITO  
 DR. PARKER, COLORADO 80138  
 P 303.840.0020

**MONTANA:**  
 P.O. BOX 16488  
 11 LONE PEAK DR., UNIT 206  
 BIG SKY, MONTANA 59716  
 P 406.995.7572

**UTAH:**  
 1960 SIDEWINDER DR., #101  
 PARK CITY, UTAH 84060  
 P 435.604.0891

www.centresky.com

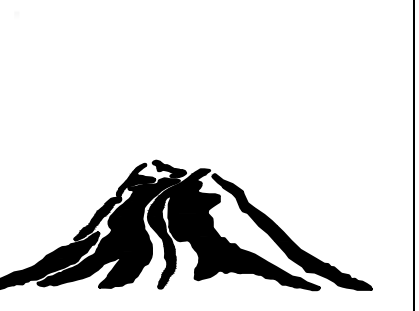

**ALPINE LAND**  
**CONSULTING, LLC**  
 P.O. BOX 234  
 RICO, COLORADO 81352  
 970-708-0326  
 GREG@ALPINELANDCONSULTING.COM

**TELLURIDE #6**  
 TELLURIDE, CO 81435

**NOT FOR**  
**CONSTRUCTION**

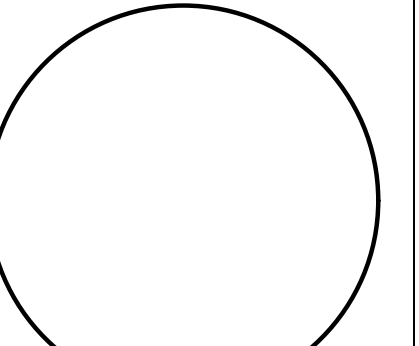

Issued For	Date
• 100% S.D.	1/13/2021
• Pricing #	
• ARC Sketch Review	1/13/2021
• 100% D.D.	
• ARC Final Review	
• 100% C.D.	
• REV. #	

Drawn By S. D'AGOSTINO  
 Date 1/13/2021  
 Project # 2021.00  
 Phase SD  
 Sheet

**C1-0.2**  
**DRB DRAINAGE**

**NOTES**

1. THIS IS A PLANNING DOCUMENT ONLY AND NOT TO BE USED FOR CONSTRUCTION.
2. MAXIMUM GRADING 2.5:1. ANY SLOPES GREATER THAN 2.5:1 ARE SHOWN AS THEY HAVE TO CONNECT INTO EXISTING STEEPER SLOPES AND TO BE CONFIRMED BY GEOTECHNICAL ENGINEER PRIOR TO FINAL CONSTRUCTION DOCUMENTS.
3. ALL EXISTING BOUNDARY AND TOPOGRAPHIC INFORMATION PROVIDED BY FOLEY ASSOCIATES INC. DATED 08/2020 WITH A BENCHMARK BEING PK NAIL IN ASPHALT ("CP 2") WITH ASSUMED ELEVATION OF 9756.68 FEET. CONTACT JEFF HASKELL AT (970) 728-6153 FOR MORE BENCHMARK INFORMATION.
4. ALL RETAINING WALL HEIGHTS AREA FINISHED GRADE TO FINISHED GRADE (RETAINED HEIGHT) AND DO NOT INCLUDE FOUNDATIONS OR CAP (SEE ARCHITECTURAL, STRUCTURAL, AND/OR LANDSCAPE PLANS).
5. RETAINING WALLS WITH PEDESTRIAN ACCESS REQUIRE HARD RAILS FOR ALL RETAINED HEIGHT OVER 2.5' (SEE ARCHITECTURAL, STRUCTURAL, AND/OR LANDSCAPE PLANS).
6. NO DETENTION PROPOSED AS THIS SITE IS PART OF CONDOMINIUM SUBDIVISION AND HAS EXISTING DRAINAGE FACILITIES.

**LEGEND**

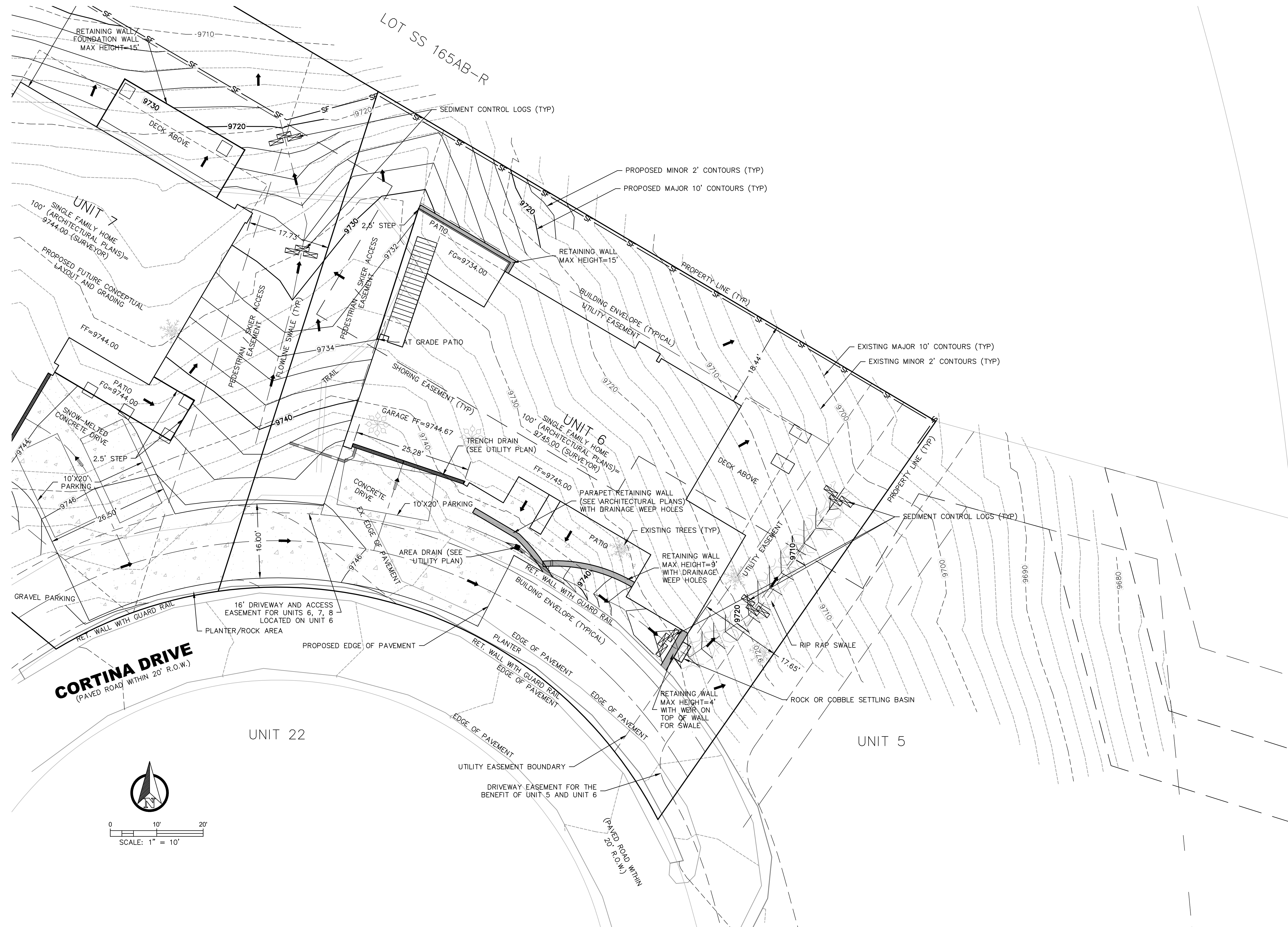
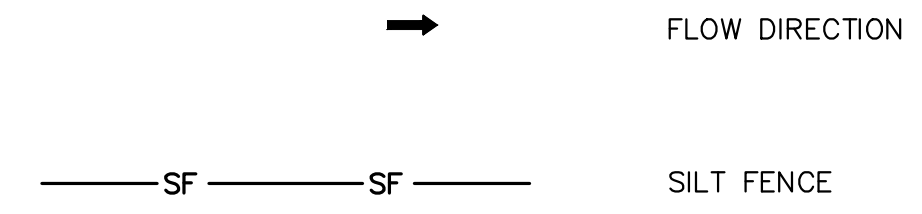

**DRB DRAINAGE AND EROSION CONTROL PLAN**

**FOR DRB ONLY AND NOT FOR CONSTRUCTION**

CALL UTILITY NOTIFICATION  
 CENTER OF COLORADO  
**1-800-922-1987**  
 OR  
**811**  
 CALL 2-BUSINESS DAYS IN ADVANCE  
 BEFORE YOU DIG, GRADE, OR  
 EXCAVATE FOR THE MARKING OF  
 UNDERGROUND MEMBER UTILITIES.

THESE PLANNING DRB DOCUMENTS WERE PREPARED BY ME AND UNDER MY DIRECT SUPERVISION ON BEHALF OF ALPINE LAND CONSULTING, LLC FOR SILVER GLADE DEVELOPMENT COMPANY AND INCLUDES PRELIMINARY DRB PLANNING DESIGN ONLY, AND DOES NOT INCLUDE ANY OTHER PLANNING OR ENGINEERING.

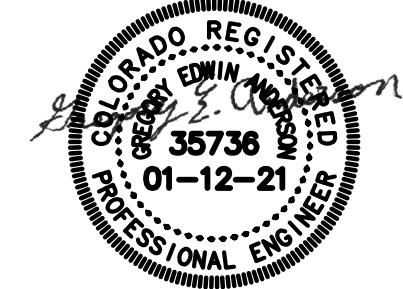

GREGORY E. ANDERSON  
 COLORADO PROFESSIONAL ENGINEER  
 REGISTRATION NO. 35736

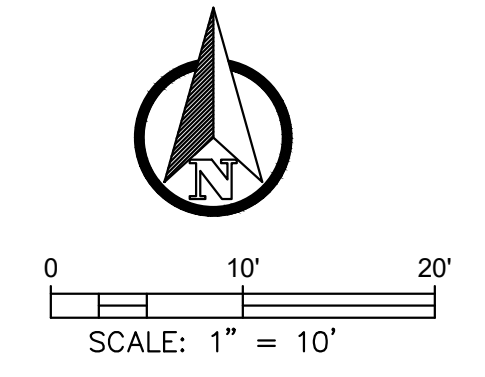

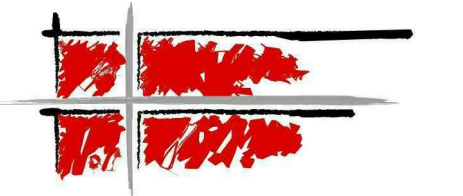

**COLORADO:**  
 10125 RANCHO MONTECITO  
 DR. PARKER, COLORADO 80138  
 P.303.840.0020

**MONTANA:**  
 P.O. BOX 161488  
 11 LONE PEAK DR., UNIT 206  
 BIG SKY, MONTANA 59716  
 P.406.995.7572

**UTAH:**  
 1960 SIDEWINDER DR., #101  
 PARK CITY, UTAH 84060  
 P.435.604.0891

www.centresky.com



**ALPINE LAND**  
**CONSULTING, LLC**  
 P.O. BOX 234  
 RICO, COLORADO 81352  
 970-708-0326  
 GREG@ALPINELANDCONSULTING.COM

TELLURIDE #6  
 TELLURIDE, CO 81435

NOT FOR  
 CONSTRUCTION

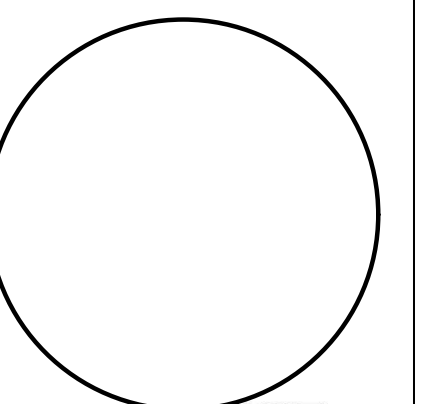

Issued For	Date
• 100% S.D.	1/13/2021
• Pricing #	
• ARC Sketch Review	1/13/2021
• 100% D.D.	
• ARC Final Review	
• 100% C.D.	
• REV. #	

Drawn By S. D'AGOSTINO  
 Date 1/13/2021  
 Project # 2021.00  
 Phase SD  
 Sheet

C1-0.3

DRB UTILITY

**NOTES**

1. THIS IS A PLANNING DOCUMENT ONLY AND NOT TO BE USED FOR CONSTRUCTION.
2. ALL EXISTING BOUNDARY AND TOPOGRAPHIC INFORMATION PROVIDED BY FOLEY ASSOCIATES INC. DATED 08/2020 WITH A BENCHMARK BEING PK NAIL IN ASPHALT ("CP 2") WITH ASSUMED ELEVATION OF 9756.68 FEET. CONTACT JEFF HASKELL AT (970) 728-6153 FOR MORE BENCHMARK INFORMATION. SOME OF THE UTILITY SERVICES LOCATIONS SHOWN ON THIS PLAN ARE FROM MAPPING AS-BUILT INFORMATION ONLY AND NOT CONFIRMED.
3. ALL UTILITY LOCATES TO BE PERFORMED PRIOR TO FINAL DESIGN. IT IS RECOMMEND THAT THE SEWER TAP IS PLOT HOLED PRIOR TO FINAL DESIGN IN ORDER TO DETERMINE IF THE SEWER REQUIRES A PUMP IN THE MECHANICAL ROOM.

**FOR DRB ONLY AND NOT FOR CONSTRUCTION**

CALL UTILITY NOTIFICATION  
 CENTER OF COLORADO  
**1-800-922-1987**  
 OR  
**811**  
 CALL 2-BUSINESS DAYS IN ADVANCE  
 BEFORE YOU DIG, GRADE, OR  
 EXCAVATE FOR THE MARKING OF  
 UNDERGROUND MEMBER UTILITIES.

THESE PLANNING DRB DOCUMENTS WERE PREPARED BY ME AND UNDER MY DIRECT SUPERVISION ON BEHALF OF ALPINE LAND CONSULTING, LLC FOR SILVER GLADE DEVELOPMENT COMPANY AND INCLUDES PRELIMINARY DRB PLANNING DESIGN ONLY, AND DOES NOT INCLUDE ANY OTHER PLANNING OR ENGINEERING.

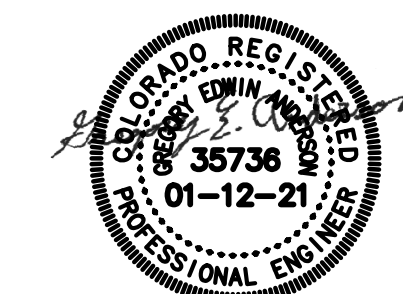

GREGORY E. ANDERSON  
 COLORADO PROFESSIONAL ENGINEER  
 REGISTRATION NO. 35736

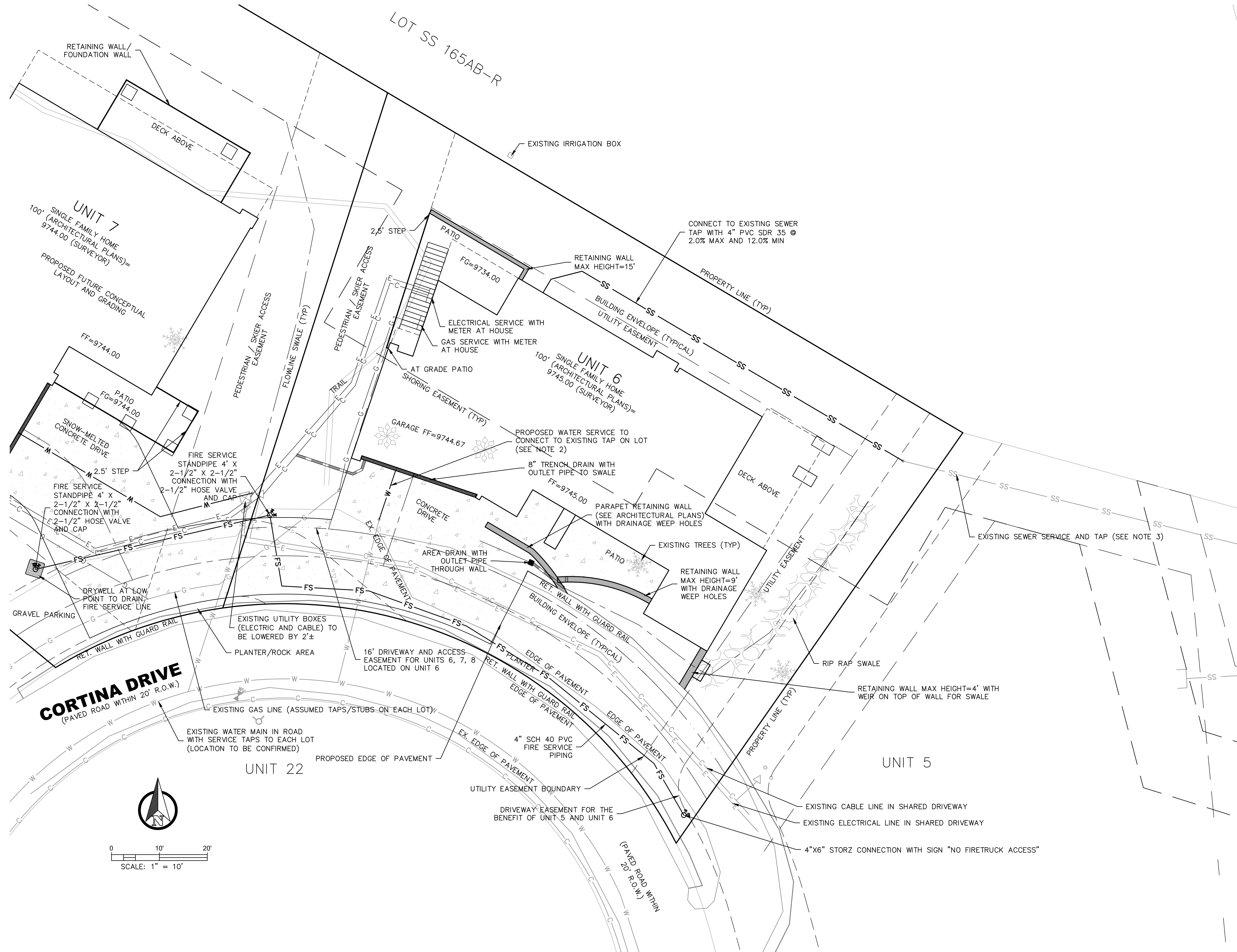

**DRB UTILITY PLAN**



**COLORADO:**  
 10125 RANCHO MONTECITO  
 DR. PARKER, COLORADO 80138  
 P 303.840.0020

**MONTANA:**  
 P.O. BOX 161488  
 11 LONE PEAK DR., UNIT 206  
 BIG SKY, MONTANA 59716  
 P 406.995.7572

**UTAH:**  
 1960 SIDEWINDER DR., #101  
 PARK CITY, UTAH 84060  
 P 435.604.0891

www.centresky.com

TELLURIDE #6  
 TELLURIDE, CO 81435

NOT FOR  
 CONSTRUCTION

Issued For	Date
• 100% S.D.	01/14/2021
• Pricing #	-
• ARC Sketch Review	01/14/2021
• 100% D.D.	-
• ARC Final Review	-
• 100% C.D.	-
• REV. #	-

Drawn By S. D'AGOSTINO  
 Date 01/14/2021  
 Project # 2021.00  
 Phase SD  
 Sheet

**A1-0.1**  
**ARCHITECTURAL**  
**SITE PLAN**

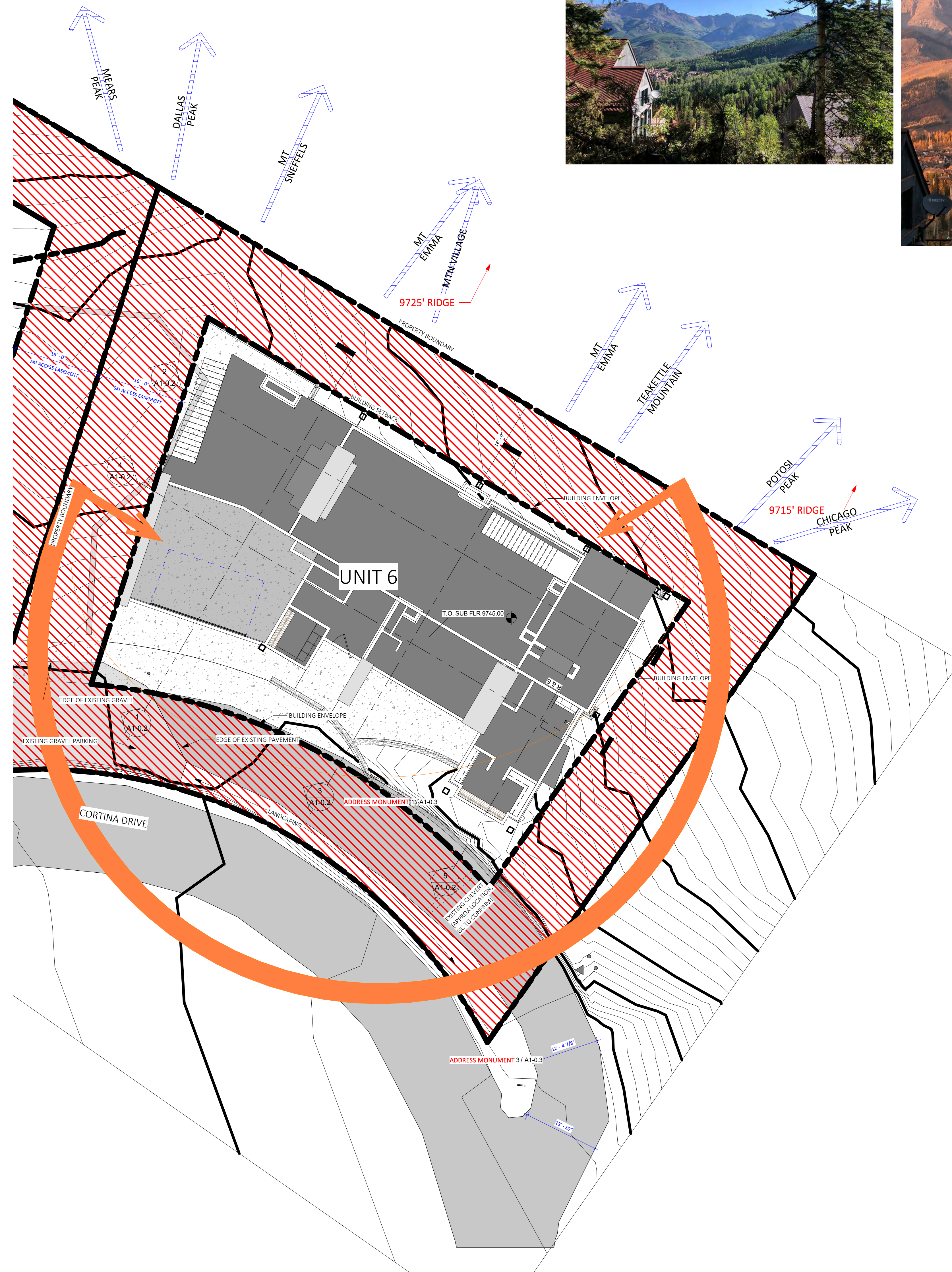

**LEGEND**

--- DRAINAGE	SNOW MELT LOCATIONS
- - - LIMITS OF CONSTRUCTION	ASPHALT
~ EROSION CONTROL	CONCRETE
— NEW GRADE LINE	SNOW STORAGE
~ PREVIOUS GRADE LINE	DRAINTILE
W — W NEW WATER LINE	
S — S NEW SEWER LINE	
UE — UE — UE NEW ELECTRICAL LINE	

**STRUCTURAL ELEVATIONS**

T.O. SLAB @ ROCK BOTTOM	78'-0" = 9723'
T.O. SLAB @ LOWER LEVEL	89'-0" = 9734'
T.O. SLAB @ GARAGE	99'-8" = 9744'-8"
T.O. SUBFLOOR @ MAIN LEVEL	100'-0" = 9745'

- GENERAL NOTES**
- SEE CIVIL PLANS FOR GRADING & ADDITIONAL SITE DETAILS.
  - ALL PERIMETER FOUNDATION DRAINS TO EXIT TO DAYLIGHT.
  - ALL CONCRETE WASTE SHALL BE CONTAINED ON SITE AND PROPERLY DISPOSED OF AT PROJECT COMPLETION. CONCRETE WASHOUT WITHIN THE ROADSIDE DITCHES IS STRICTLY PROHIBITED.
  - EXCESS SOIL FROM CONSTRUCTION TO BE RELOCATED ON SITE W/ GEOTECHNICAL ENGINEER APPROVAL.
  - ANY DAMAGE TO THE EXISTING ROADWAY, INCLUDING THE AS SURFACE, SHOULDER GRAVEL, ROADSIDE DITCH, EXISTING CURBS, AND EXISTING VEGETATION AND EROSION CONTROL MEASURES SHALL BE REPAIRED BY THE GENERAL CONTRACTOR.

2 ARCHITECTURAL SITE PLAN  
 1" = 10'-0"  
 TRUE NORTH





**COLORADO:**  
 10125 RANCHO MONTECITO  
 DR. PARKER, COLORADO 80138  
 P.303.840.0020

**MONTANA:**  
 P.O. BOX 161488  
 11 LONE PEAK DR., UNIT 206  
 BIG SKY, MONTANA 59716  
 P.406.995.7572

**UTAH:**  
 1960 SIDEWINDER DR., #101  
 PARK CITY, UTAH 84060  
 P.435.604.0891

www.centresky.com

TELLURIDE #6  
 TELLURIDE, CO 81435

NOT FOR  
 CONSTRUCTION



Issued For	Date
• 100% S.D.	01/14/2021
• Pricing #	-
• ARC Sketch Review	01/14/2021
• 100% D.D.	-
• ARC Final Review	-
• 100% C.D.	-
• REV. #	-

Drawn By S. D'AGOSTINO  
 Date 01/14/2021  
 Project # 2021.00  
 Phase SD  
 Sheet

**A1-0.2**  
 SITE SECTIONS

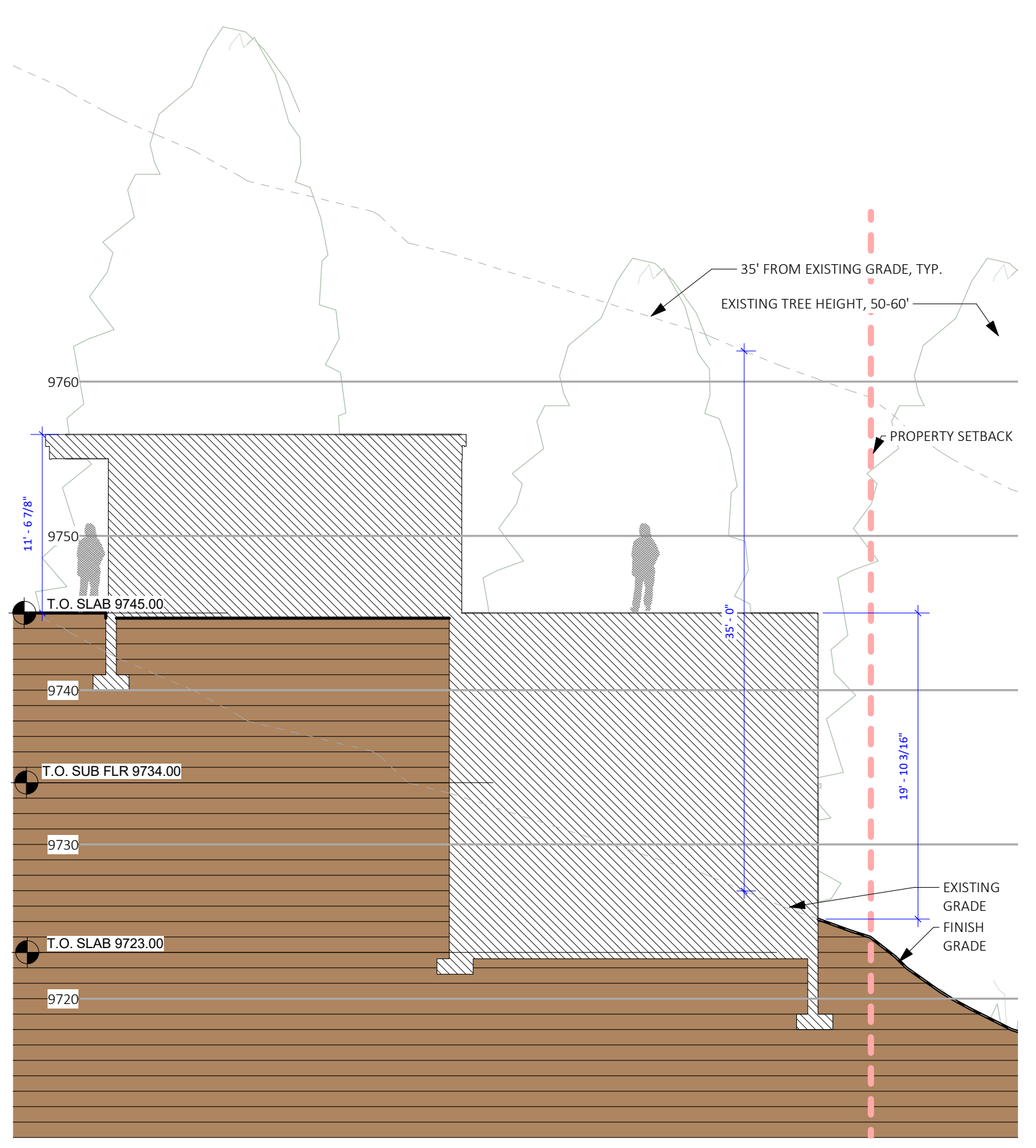

1 N/S WESTERN SITE SECTION  
 1/8" = 1'-0"

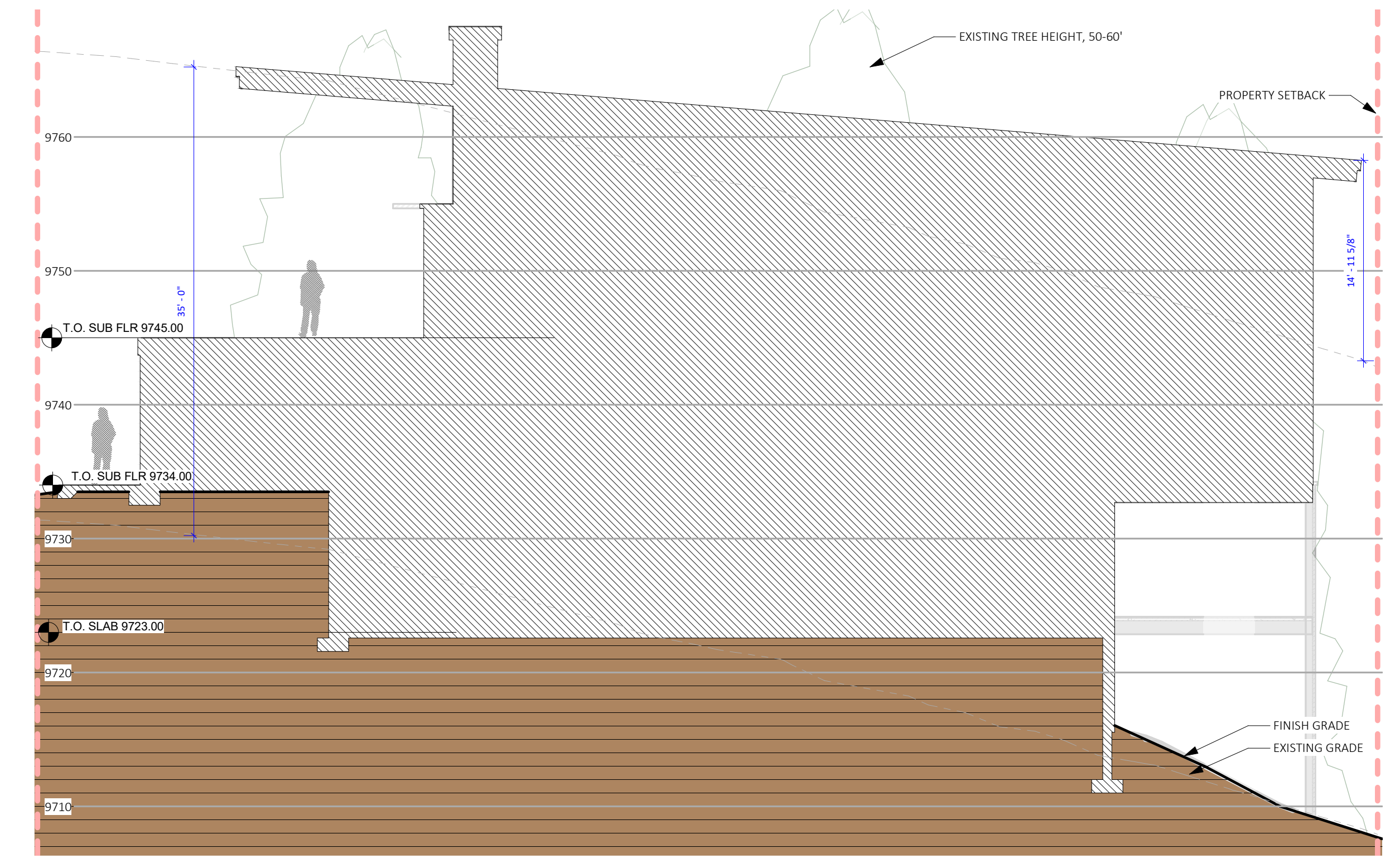

2 E/W NORTHERN SITE SECTION  
 1/8" = 1'-0"

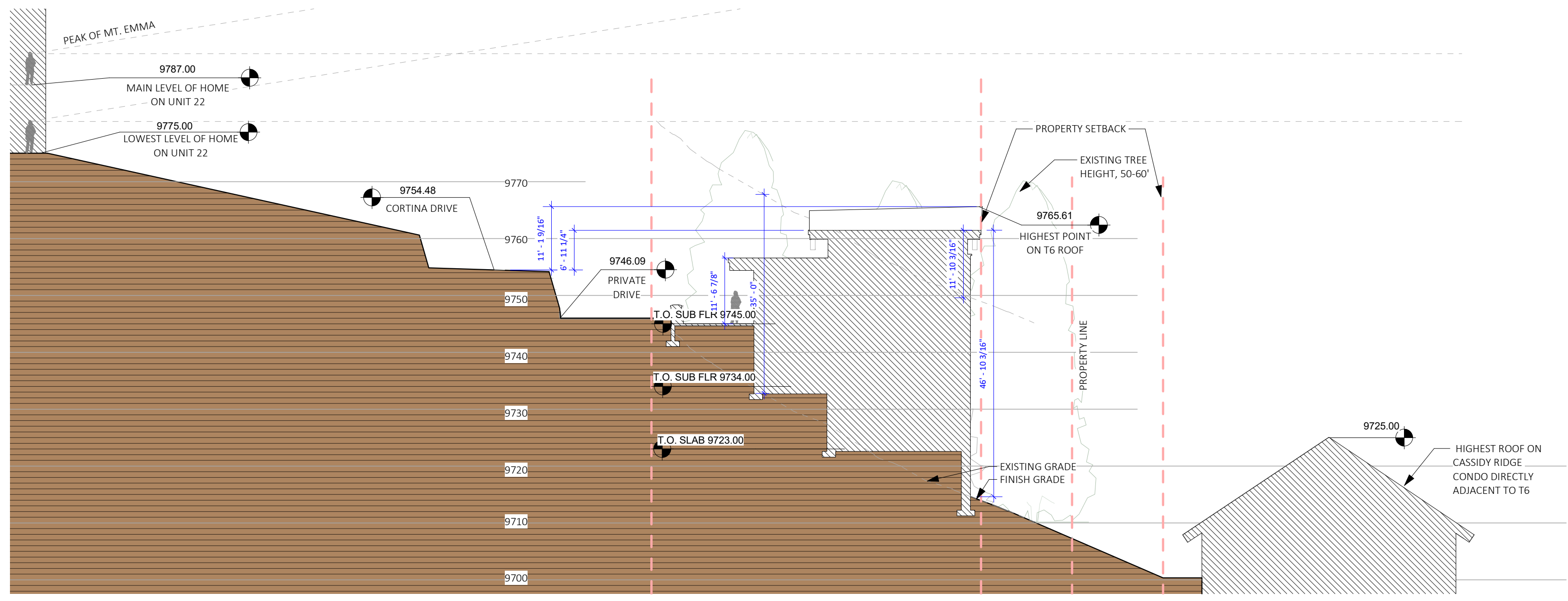

3 N/S CENTRAL SITE SECTION  
 1/16" = 1'-0"

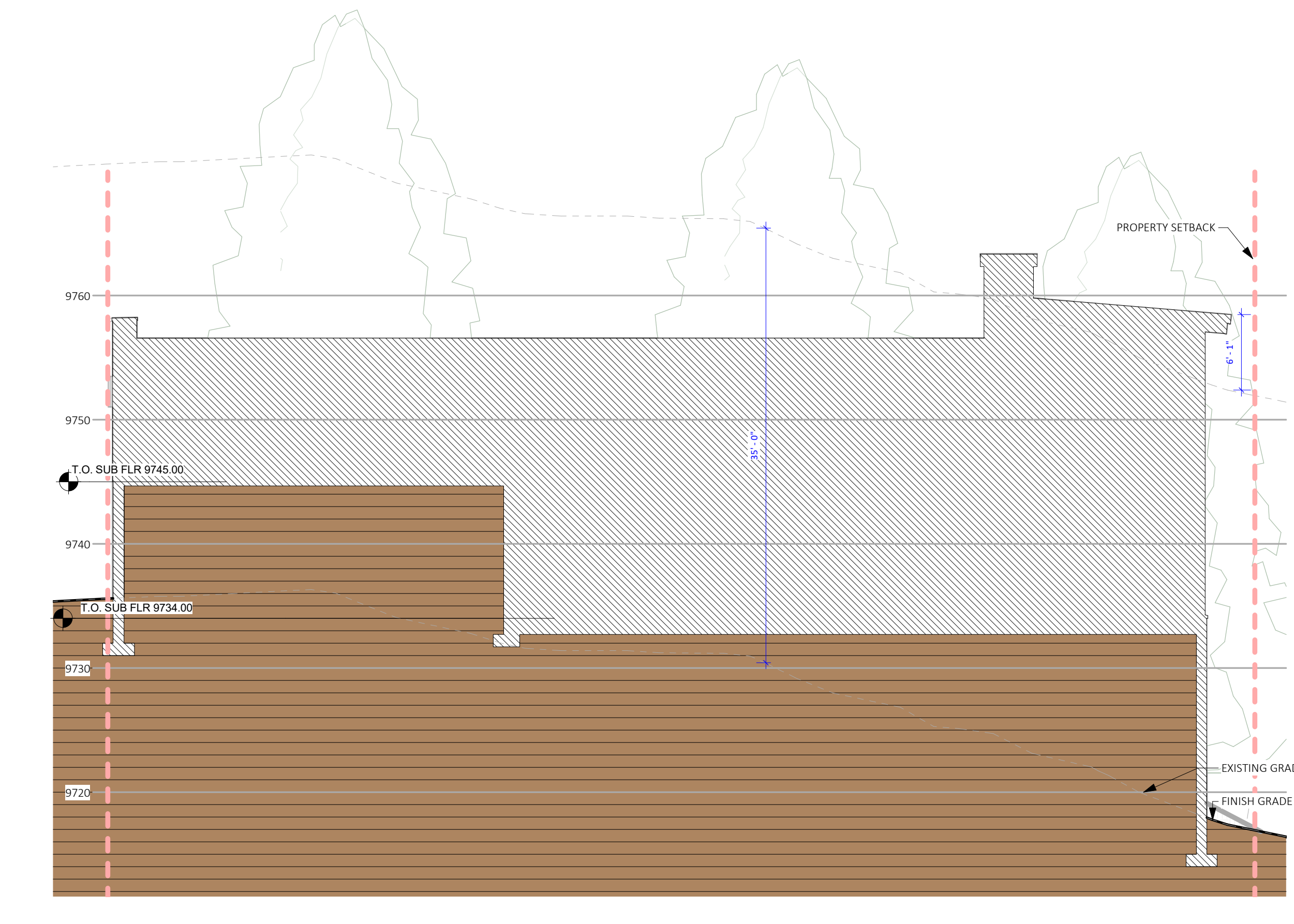

4 E/W SOUTHERN SITE SECTION  
 1/8" = 1'-0"

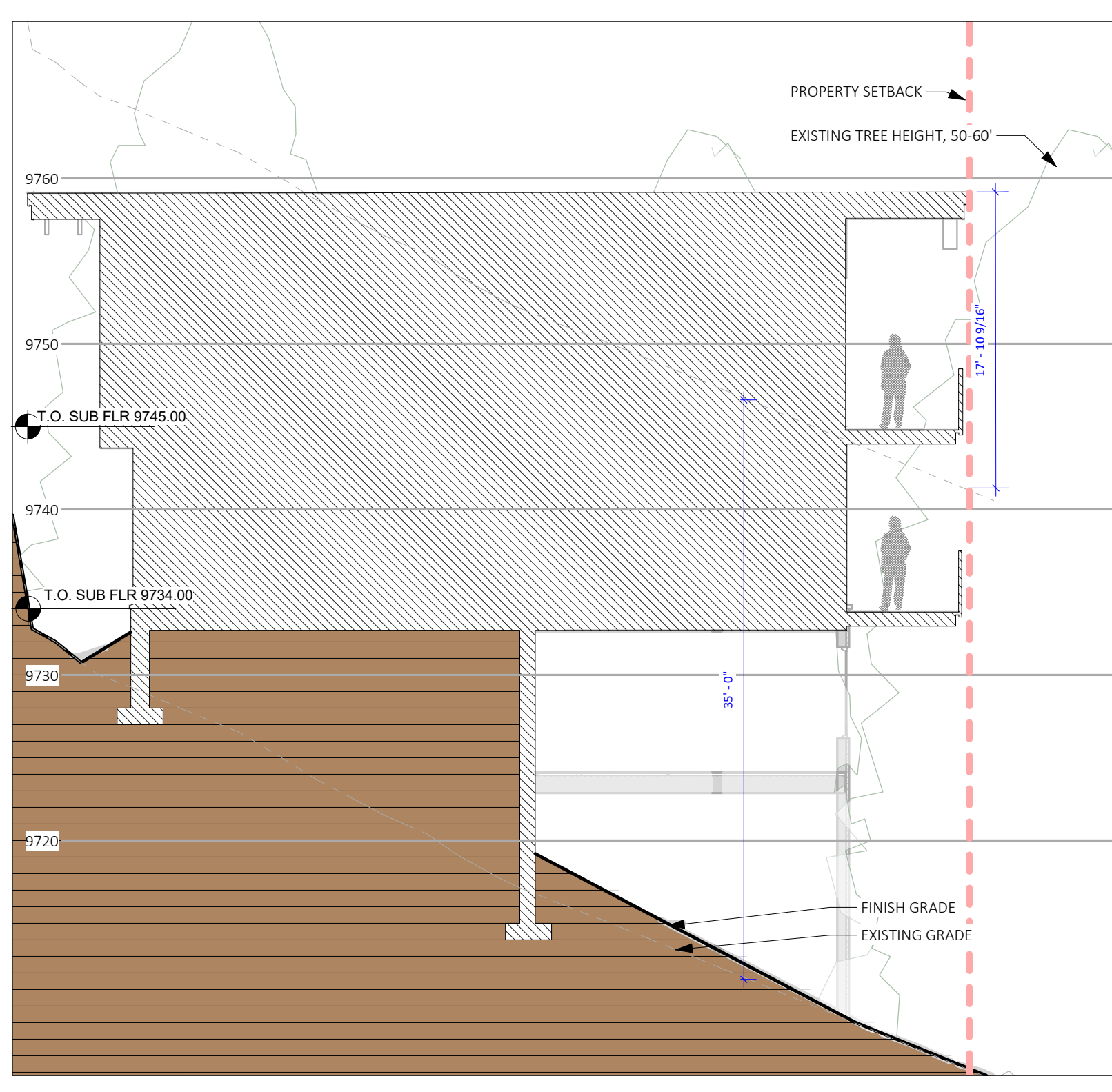

5 N/S EASTERN SITE SECTION  
 1/8" = 1'-0"

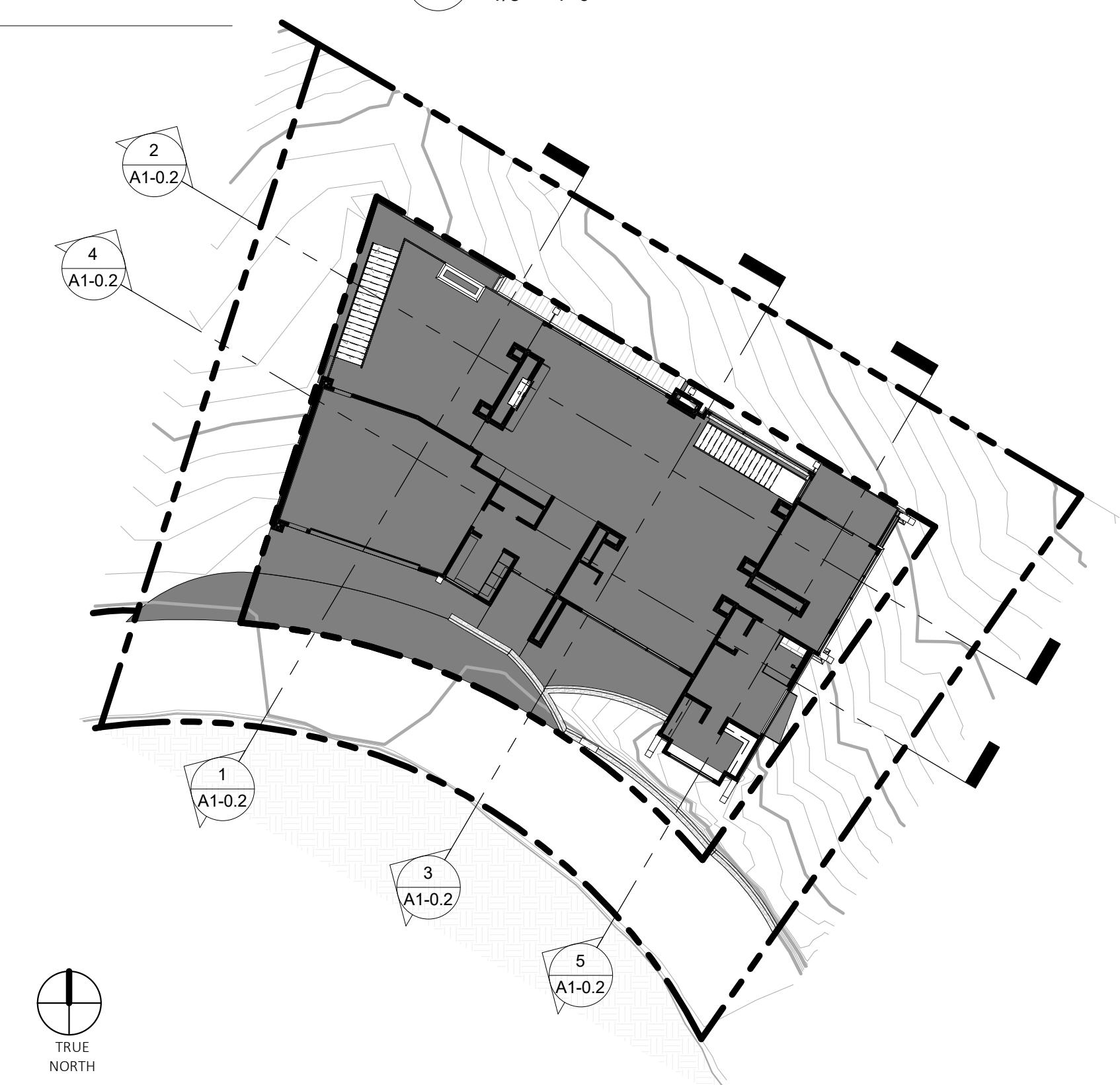

6 KEY PLAN  
 1" = 20'-0"

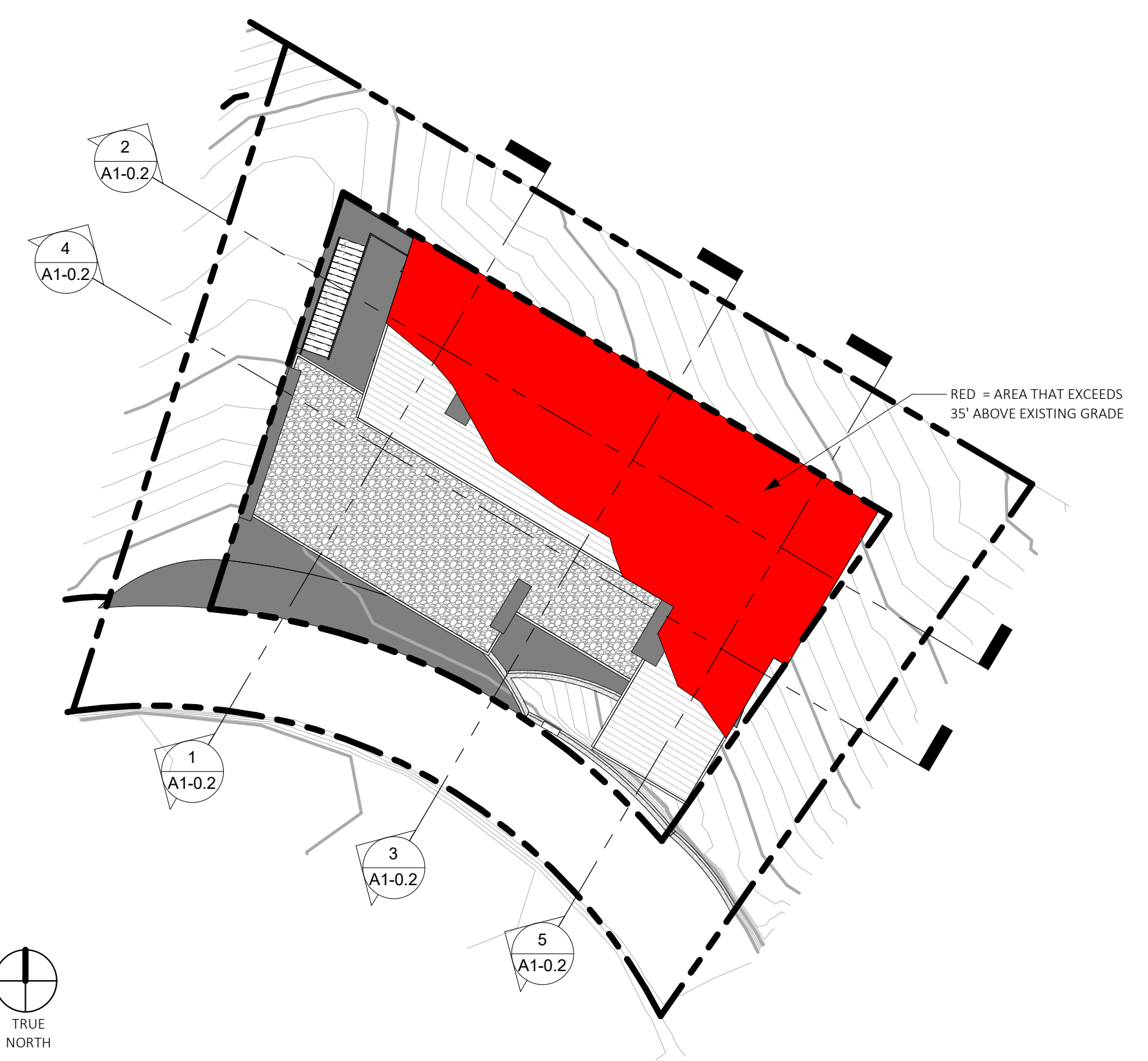

7 KEY PLAN  
 1" = 20'-0"



NEUTRA HOUSE ALUMINUM NUMBERS, BOTH SIDES, 6" TALL

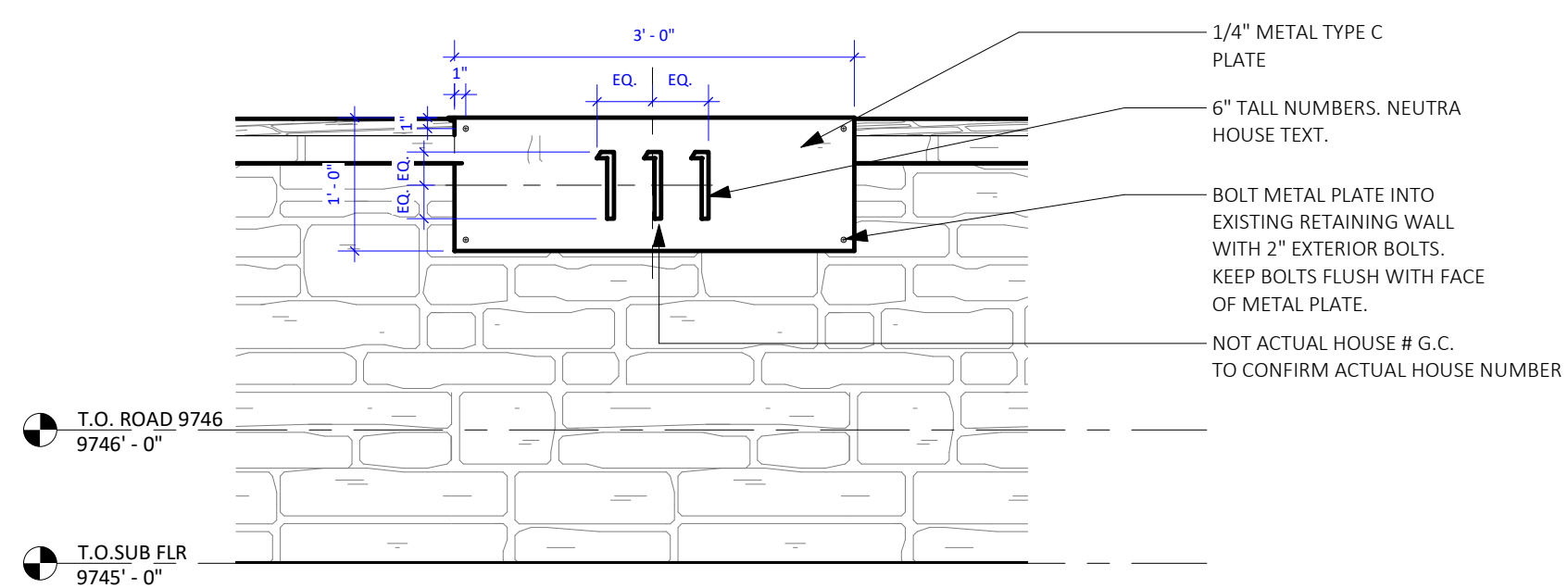

1 ADDRESS MONUMENT - ELEVATION DETAIL  
3/4" = 1'-0"

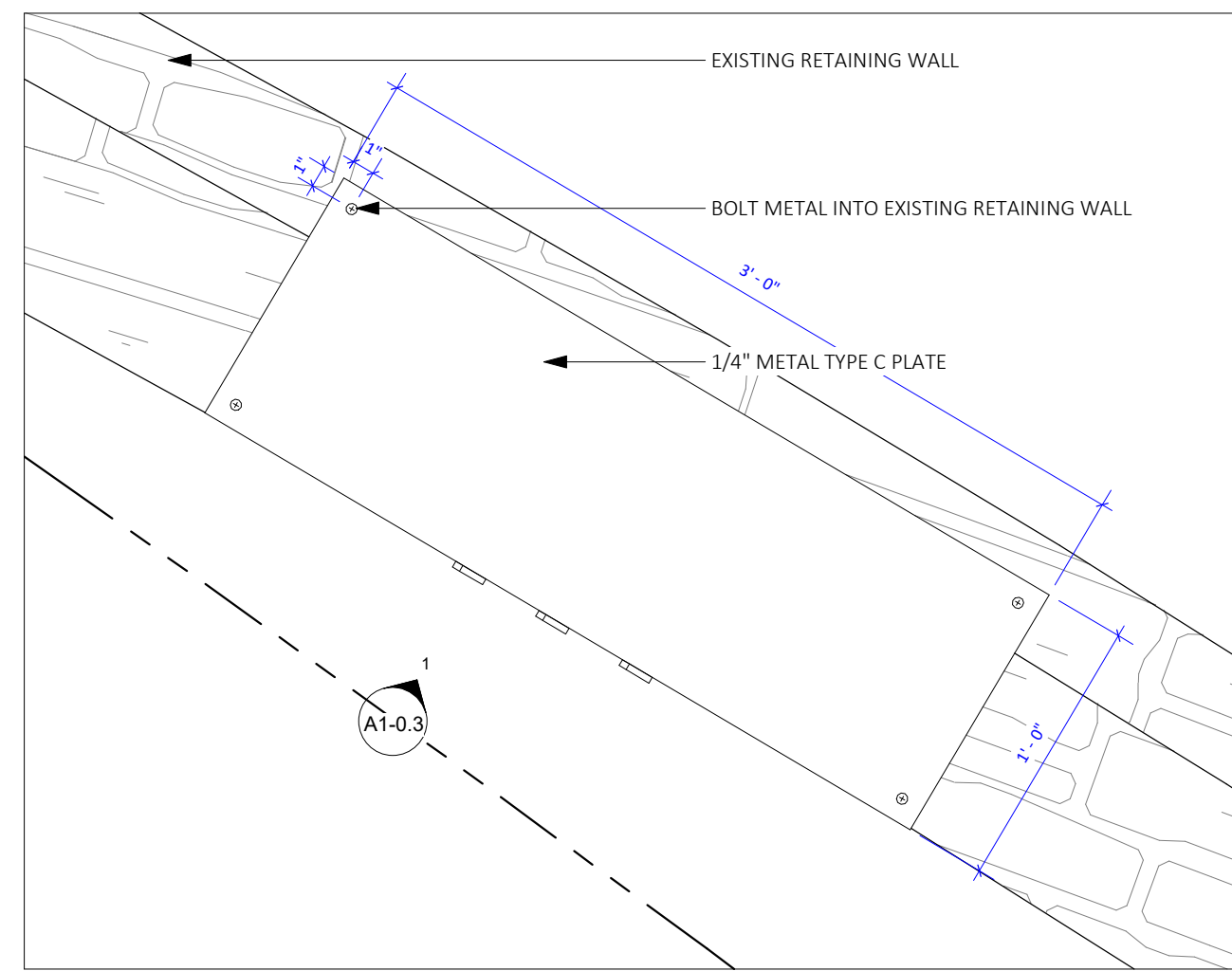

2 ADDRESS MONUMENT PLAN  
1 1/2" = 1'-0"

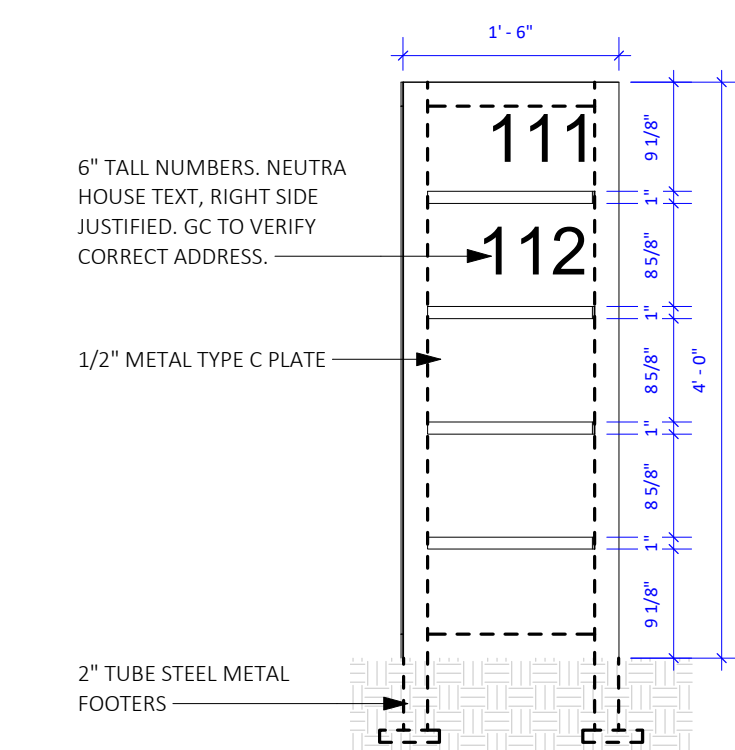

3 DOUBLE ADDRESS MONUMENT - ELEVATION  
3/4" = 1'-0"

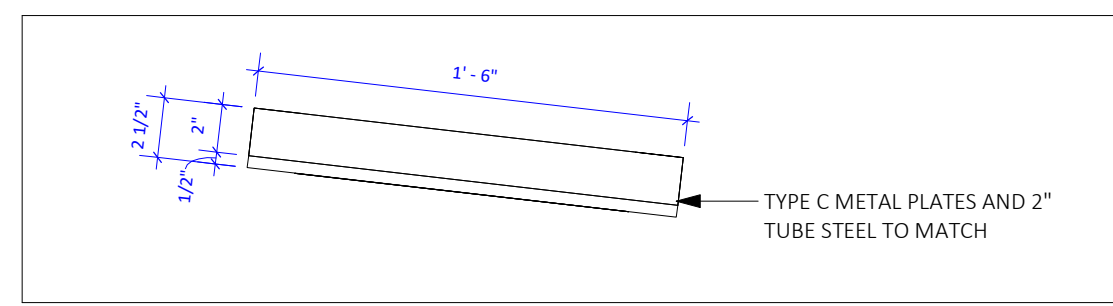

4 ADDRESS MONUMENT PLAN  
1 1/2" = 1'-0"

CONCRETE WASHOUT AREA NOTES

- Temporary concrete washout facilities shall be located a minimum of 50 ft from sensitive areas including storm drain inlets, open drainage facilities, and watercourses.
- Concrete washout within the roadside ditches is strictly prohibited.
- Washout of concrete trucks shall be performed in designated areas only.
- Once concrete wastes are washed into the designated area and allowed to harden, the concrete should be broken up, removed, and disposed of per applicable soil waste regulations. Dispose of hardened concrete on a regular basis.
- Materials used to construct temporary concrete washout facilities shall be removed from the site of the work and disposed of or recycled.
- Holes, depressions or other ground disturbance caused by the removal of the temporary concrete washout facilities shall be backfilled, repaired, and stabilized to prevent erosion.

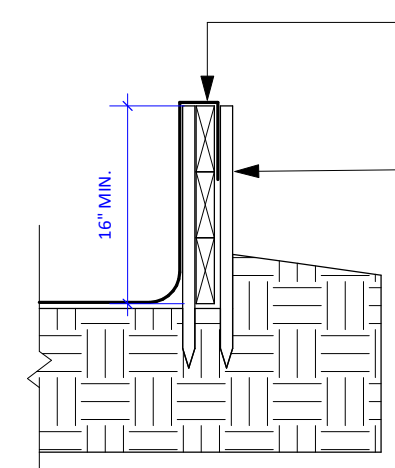
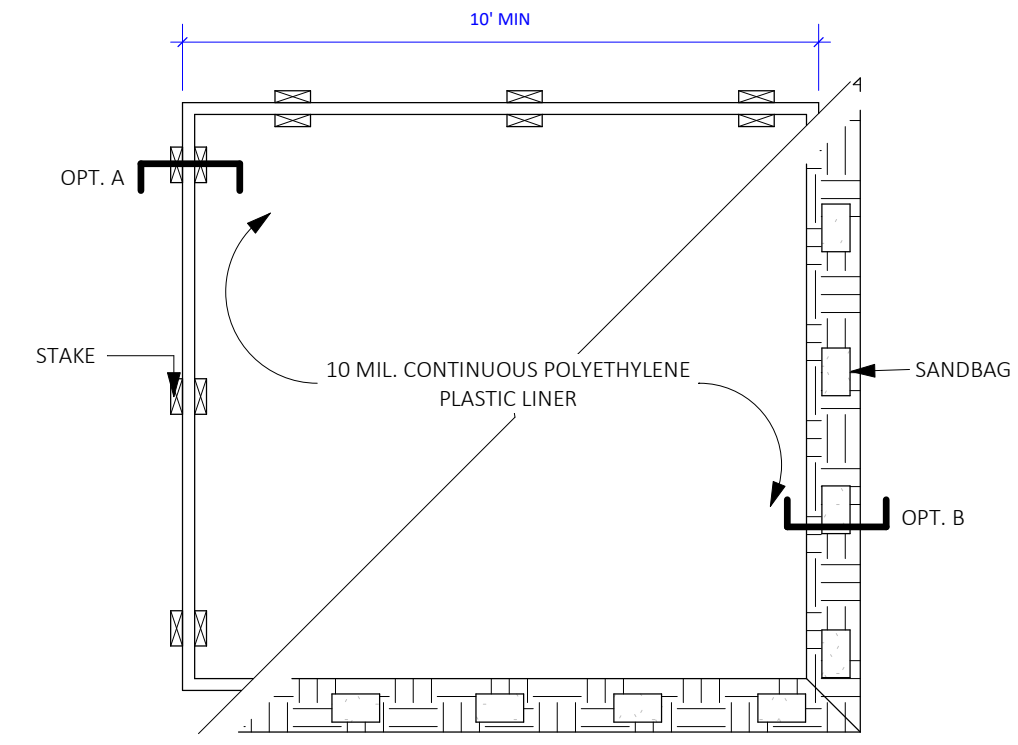

5 CONCRETE WASHOUT AREA  
3/4" = 1'-0"

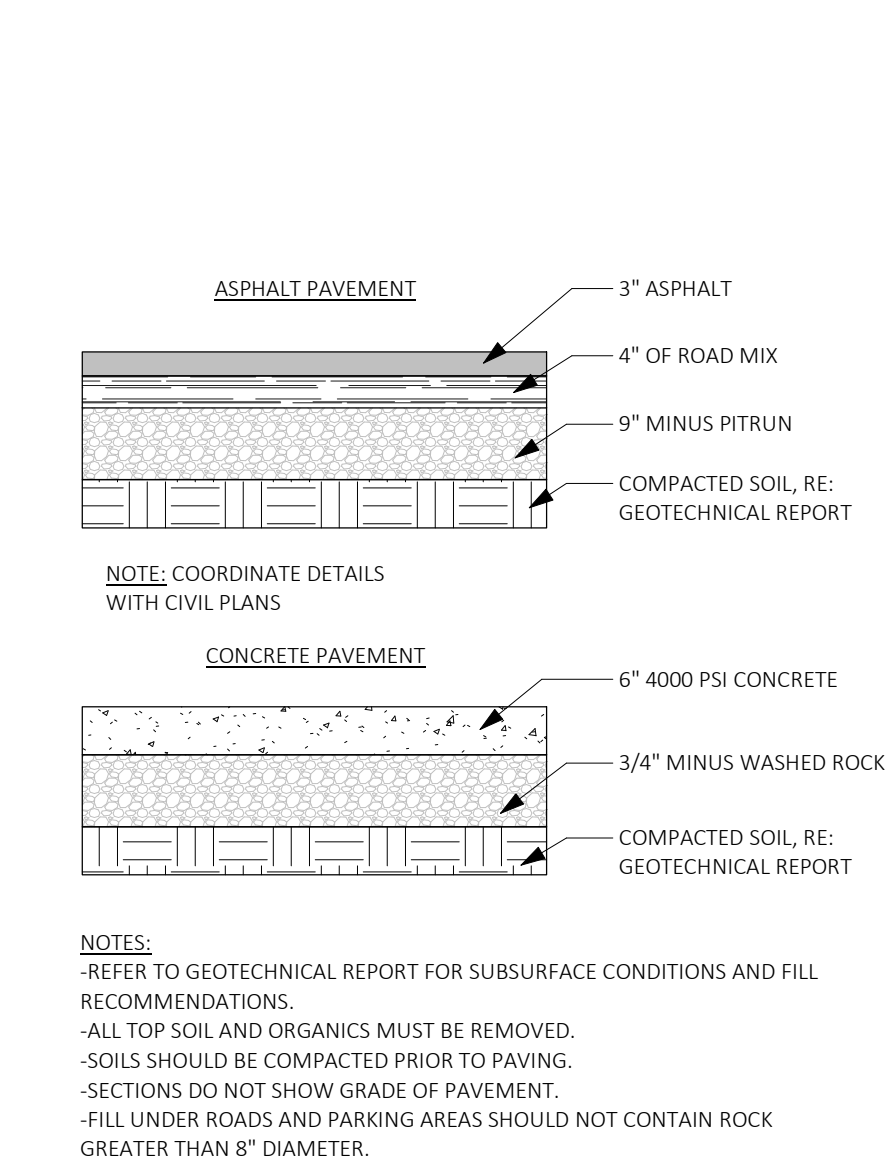
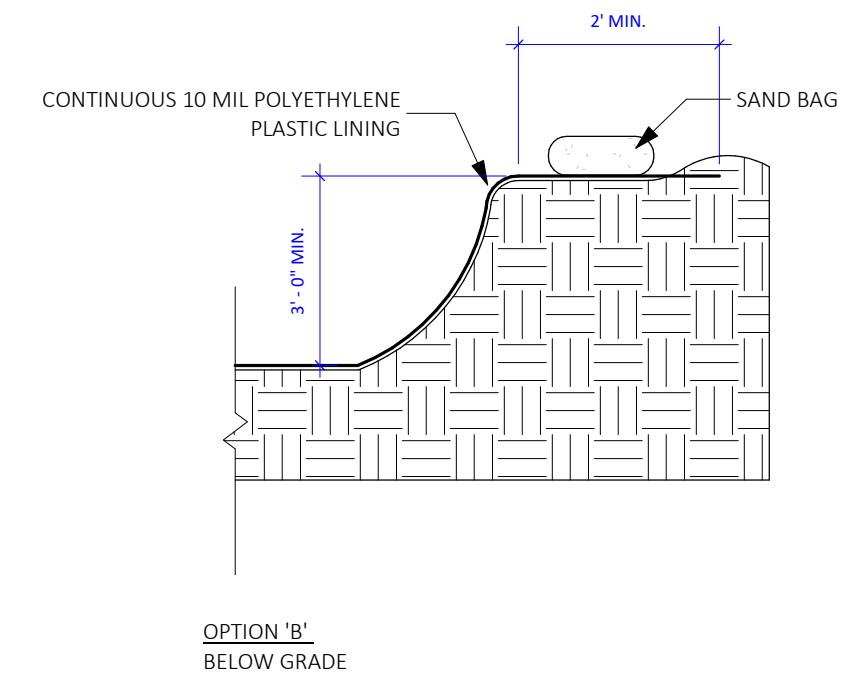

6 SITE PAVING DETAILS  
1/2" = 1'-0"

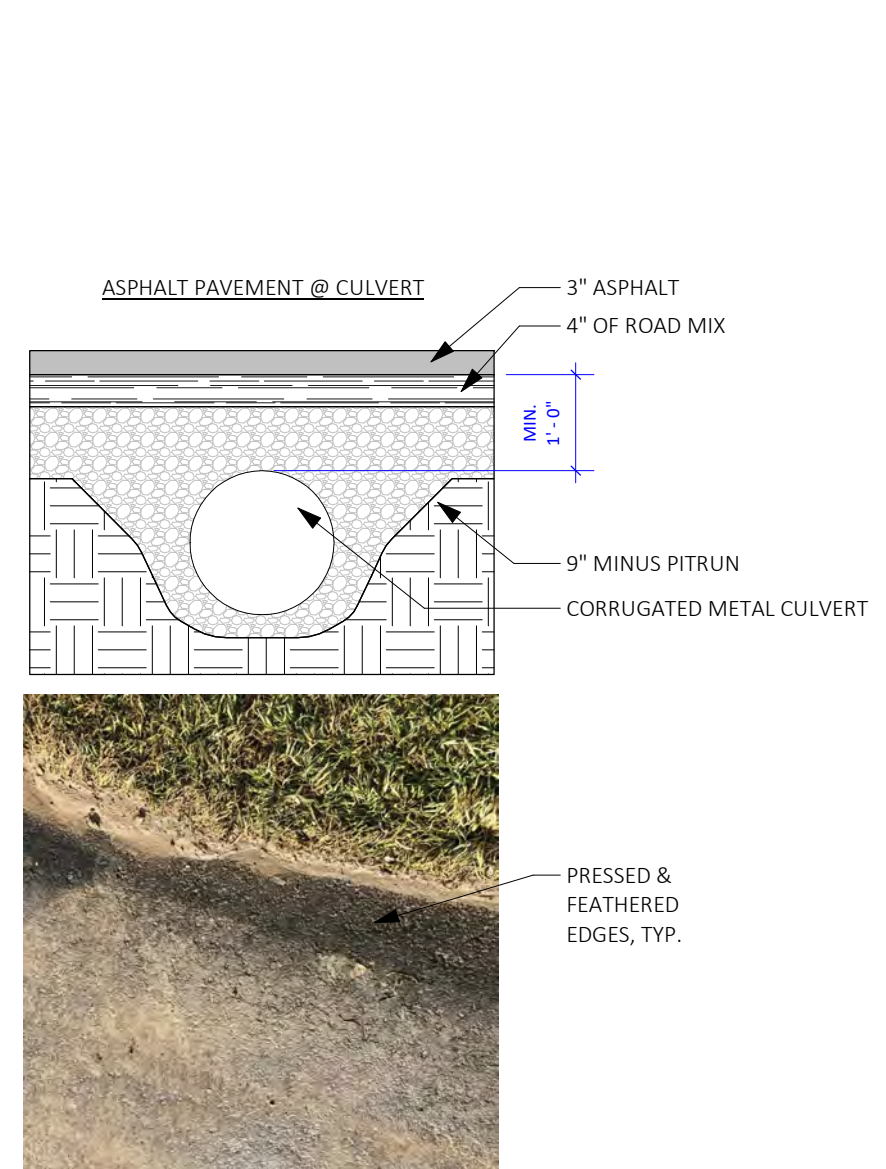

7 DRAINAGE SWALE  
1" = 1'-0"

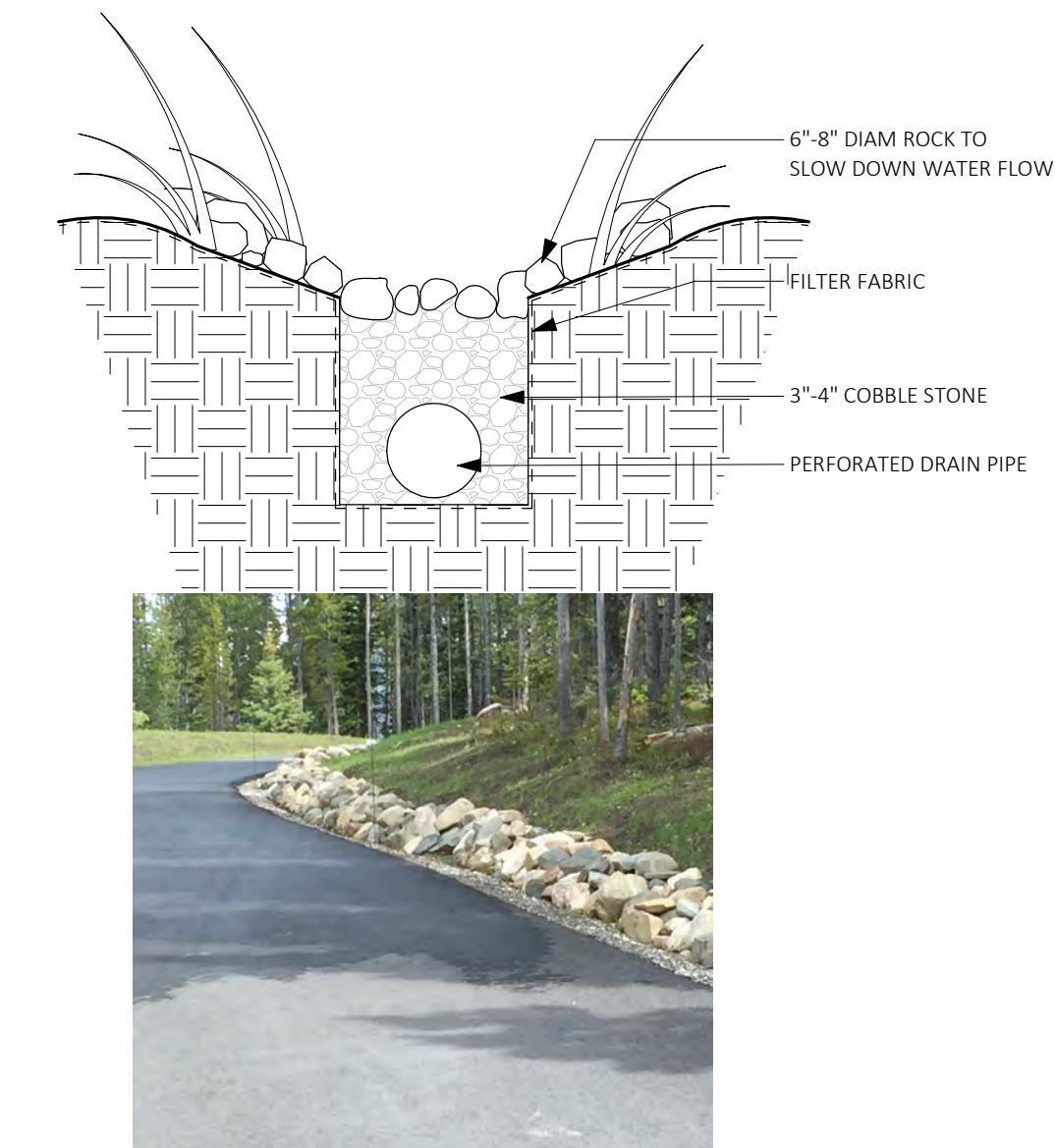

8 DRAIN TILE RUNOUT DETAIL  
1/4" = 1'-0"

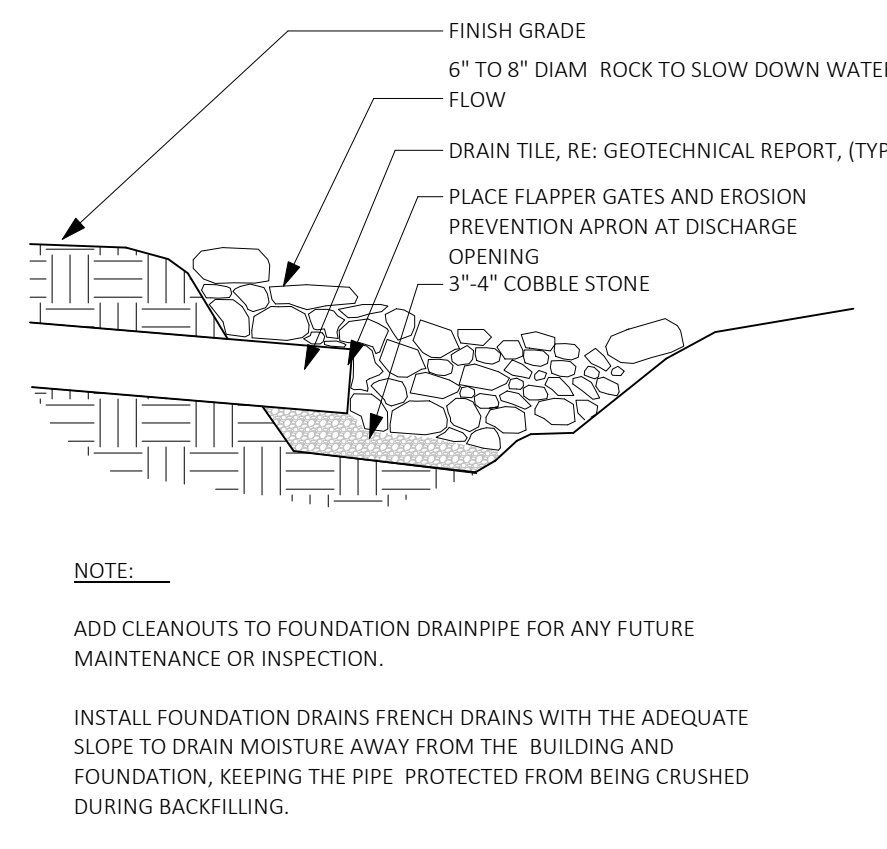

9 DRIVEWAY CURB DETAIL  
1" = 1'-0"

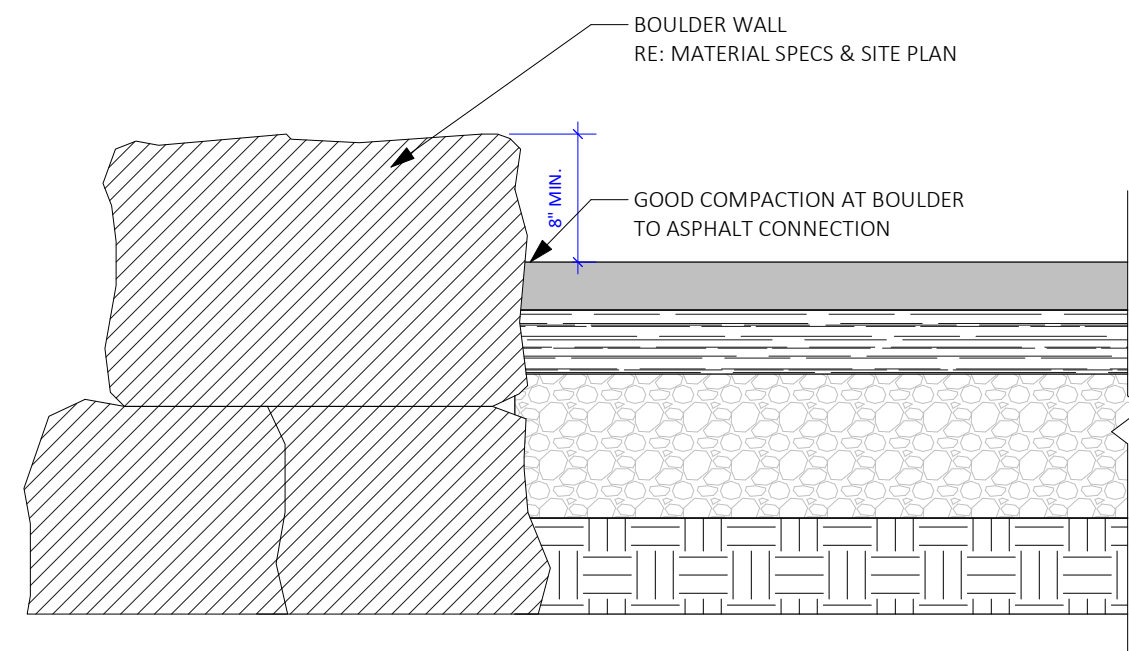

10 SITE STEPS DETAIL  
1" = 1'-0"

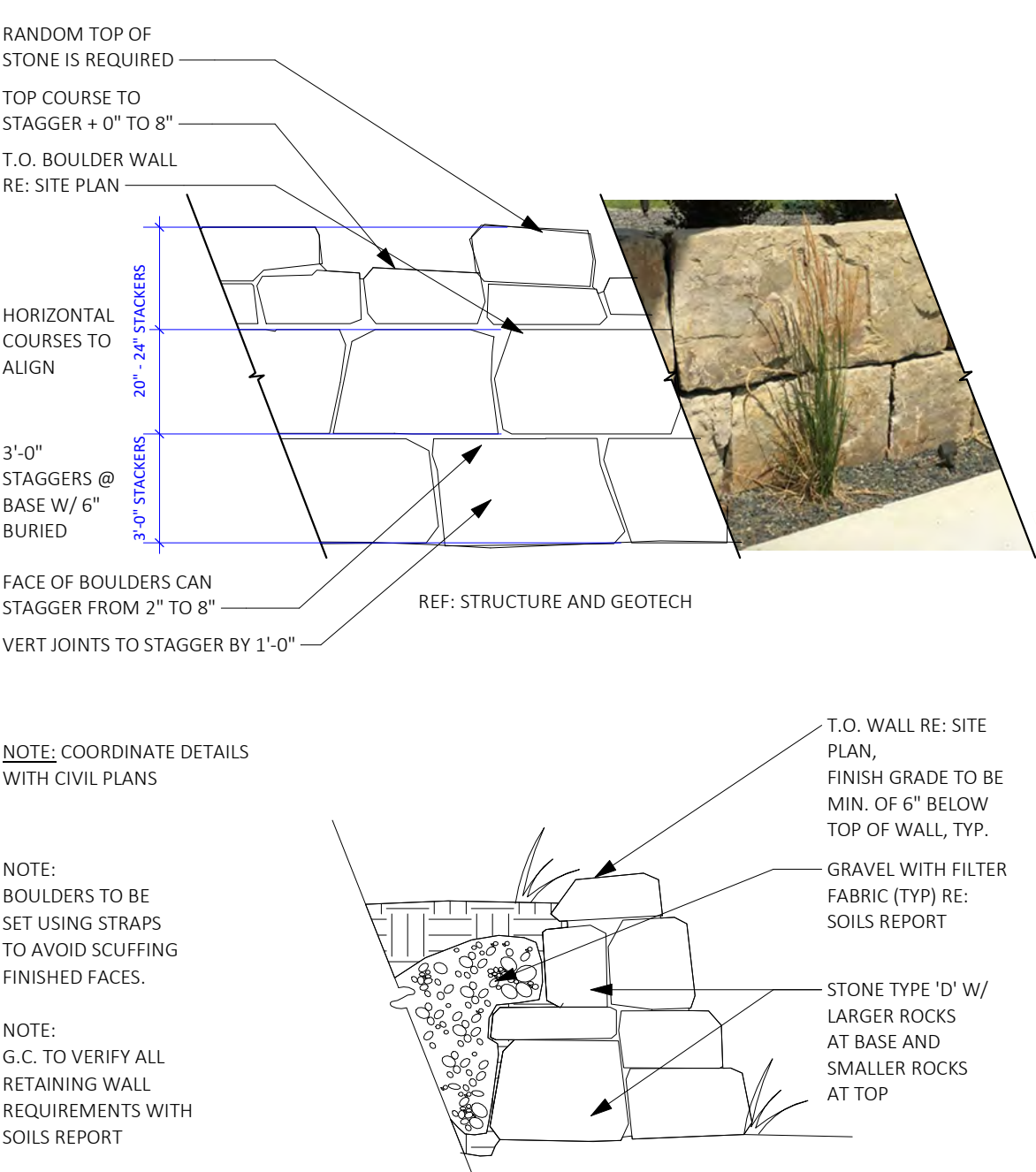
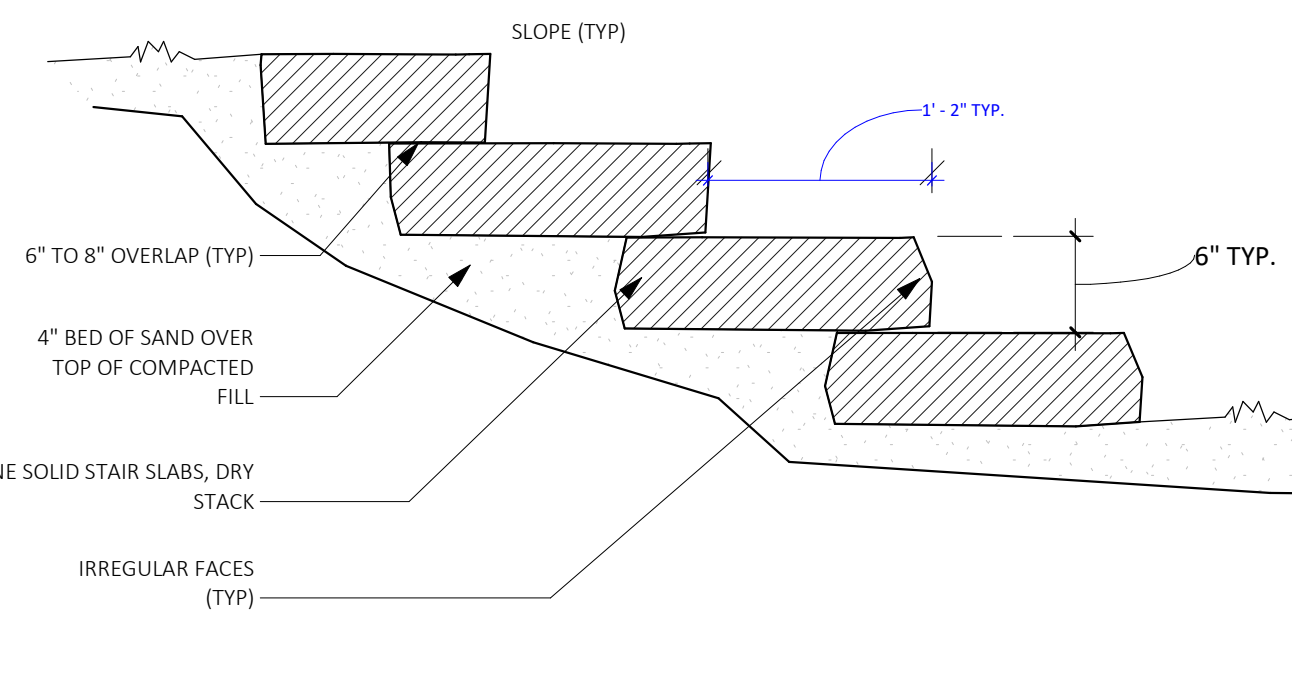

11 TYPICAL BOULDER WALL DETAIL  
1/2" = 1'-0"

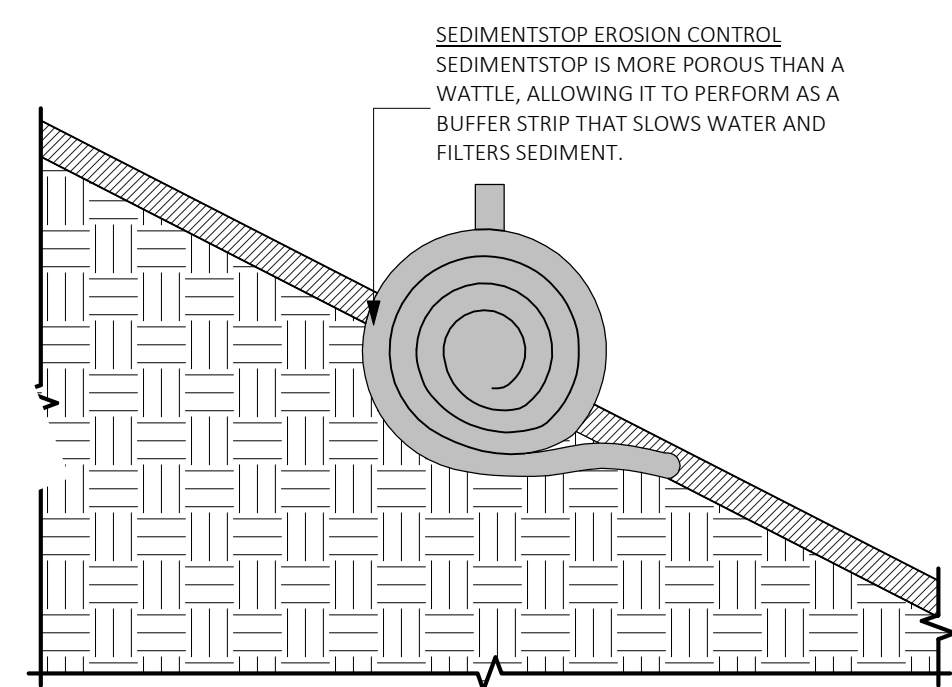

GENERAL INSTALLATION NOTES  
PREPARE SOIL BEFORE INSTALLATION.  
ANCHOR BLANKET AT TOP OF THE SLOPE IN A 6-INCH x 6-INCH WIDE TRENCH WITH A ROW OF STAPLES/STAKES APPROXIMATELY 12 INCHES APART AT THE BOTTOM OF THE TRENCH.  
FOLD A 12-INCH PORTION OF BLANKET BACK AND SECURE WITH A ROW OF STAPLES APPROXIMATELY 12 INCHES APART ACROSS THE WIDTH OF THE BLANKET.  
STAPLE THE EDGES OF PARALLEL BLANKETS WITH 2 - 5 INCHES OF OVERLAP.  
WHEN USING DOT SYSTEM, PLACES THROUGH THE APPROPRIATE STAPLE PATTERN PROVIDED BY THE MANUFACTURER.  
INSTALL SEDIMENT STOP EROSION CONTROL TO MANUFACTURER'S SPECIFICATIONS.

12 EROSION CONTROL DETAIL  
1/4" = 1'-0"

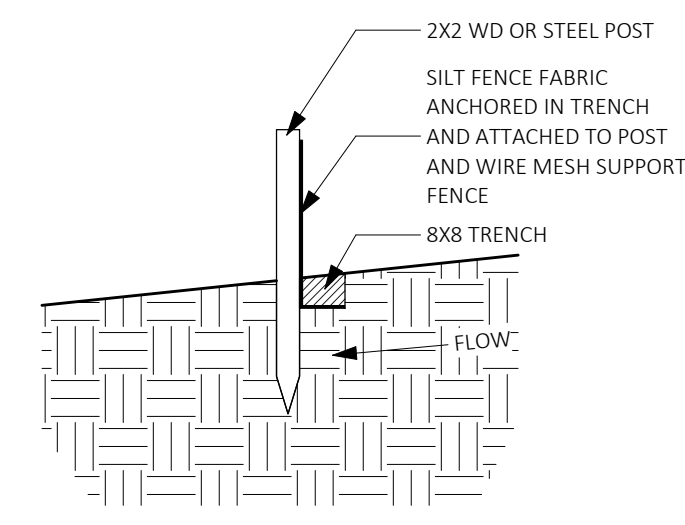

GENERAL NOTES  
FABRIC MATERIAL SHALL BE MIRAFI 300X, OR ENGINEER APPROVED EQUAL.  
SUPPORT FENCE IF USED SHALL BE 2X2 BY 14-GAUGE WIRE MESH FENCING IN 3 FOOT WIDE ROLLS.  
SILT FENCE SHOULD NOT BE USED IF GRADE IS ABOVE 50% IN EITHER DIRECTION FOR A DISTANCE OF MORE THAN 100'-0" UNLESS USED IN COMBINATION WITH TEMPORARY SEDIMENT TRAPS.  
SILT FENCE SHALL NOT BE USED TO DIVERT FLOW AND NOT INTENDED FOR CONCENTRATED FLOW CONDITIONS.  
ENDS OF EACH SEPARATE SECTION OF SILT FENCE SHOULD BE TURNED UPSLOPE A MINIMUM OF 1'-0" TO PREVENT RUNOFF FROM GOING AROUND THE END OF FENCE.

13 SILT FENCE DETAIL  
1/4" = 1'-0"

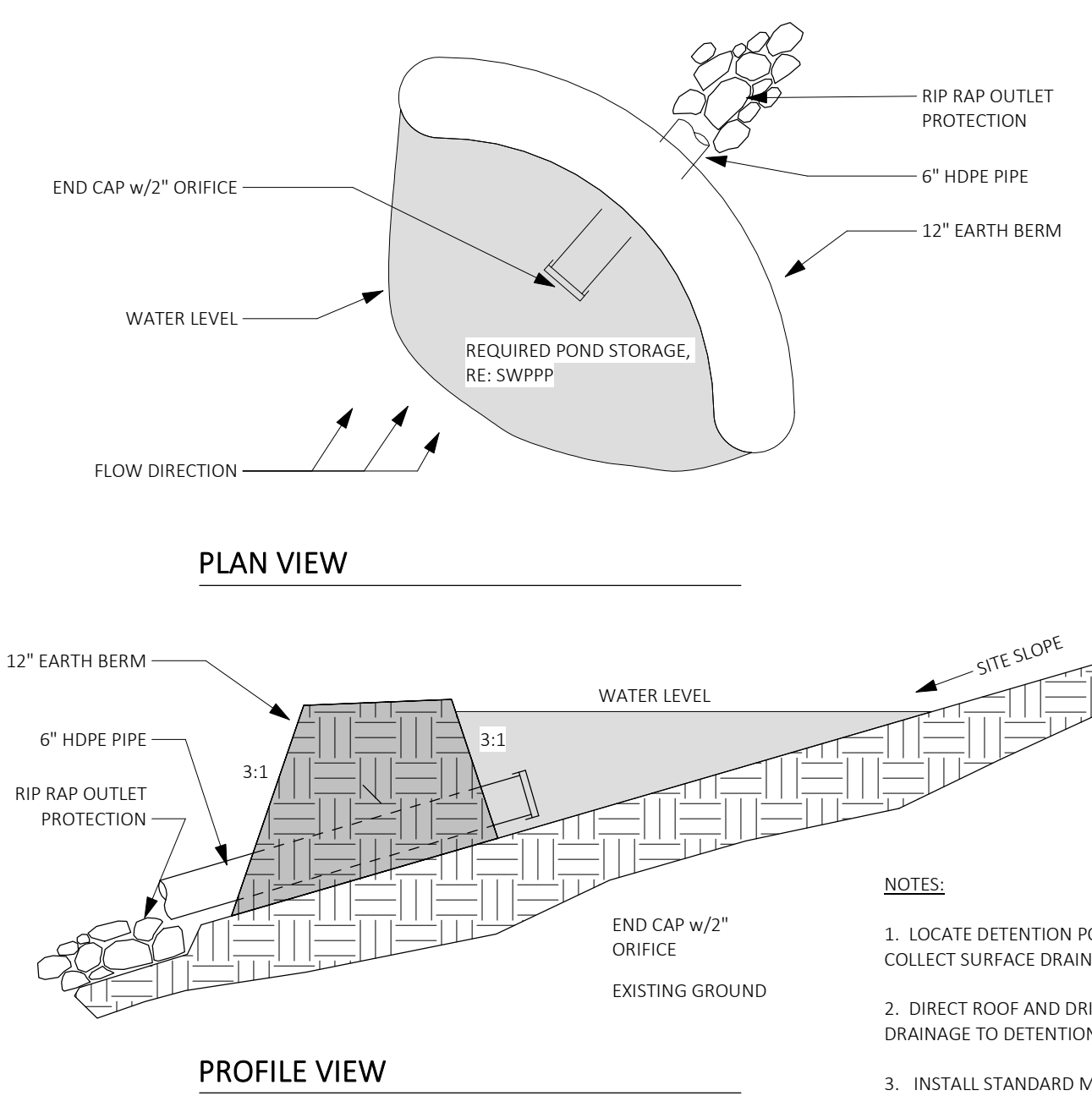

14 RETENTION POND  
1/2" = 1'-0"

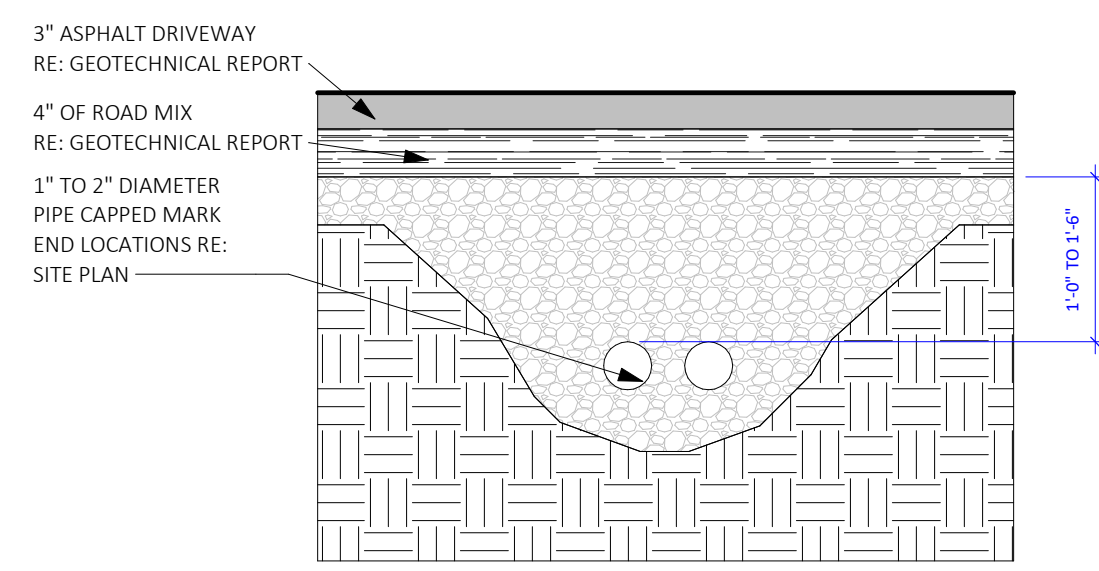

15 CONDUIT/PIPE DETAIL  
3/4" = 1'-0"



16 SAND @ PROPANE TANKS  
3/4" = 1'-0"

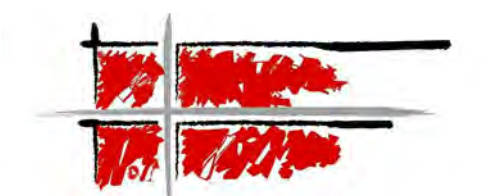

COLORADO:  
10125 RANCHO MONTECITO  
DR. PARKER, COLORADO 80138  
P 303.840.0020

MONTANA:  
P.O. BOX 161488  
11 LONE PEAK DR., UNIT 206  
BIG SKY, MONTANA 59716  
P 406.995.7572

UTAH:  
1960 SIDEWINDER DR., #101  
PARK CITY, UTAH 84060  
P 435.604.0891

www.centresky.com

TELLURIDE #6  
TELLURIDE, CO 81435

NOT FOR  
CONSTRUCTION



Issued For	Date
100% S.D.	01/14/2021
Pricing #	-
ARC Sketch Review	01/14/2021
100% D.D.	-
ARC Final Review	-
100% C.D.	-
REV. #	-

Drawn By S. D'AGOSTINO  
Date 01/14/2021  
Project # 2021.00  
Phase SD  
Sheet

A1-0.3  
SITE DETAILS



**COLORADO:**  
10125 RANCHO MONTECITO  
DR. PARKER, COLORADO 80138  
P 303.840.0020

**MONTANA:**  
P.O. BOX 161488  
11 LONE PEAK DR., UNIT 206  
BIG SKY, MONTANA 59716  
P 406.995.7572

**UTAH:**  
1960 SIDEWINDER DR., #101  
PARK CITY, UTAH 84060  
P 435.604.0891

www.centresky.com

TELLURIDE #6  
TELLURIDE, CO 81435

NOT FOR  
CONSTRUCTION



A1-1.0  
LOWER LEVEL PLAN

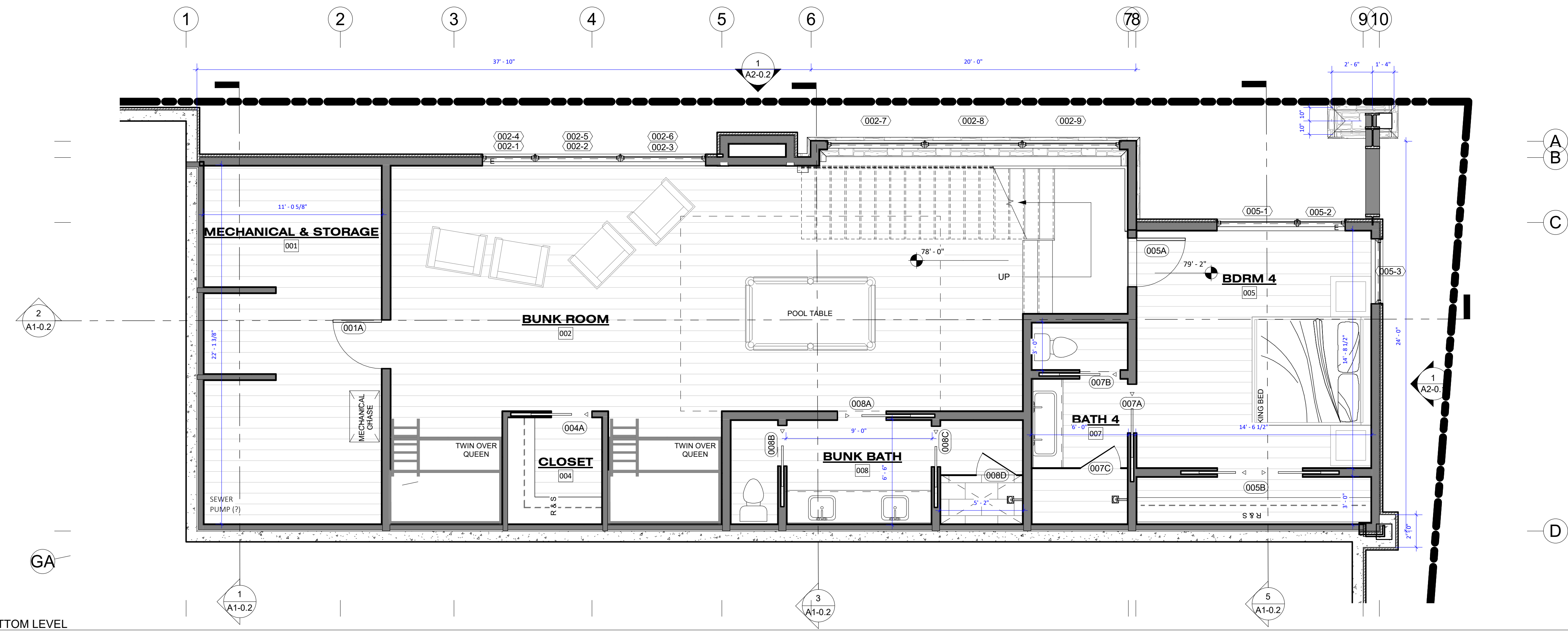

2 A ROCK BOTTOM LEVEL  
1/4" = 1'-0"

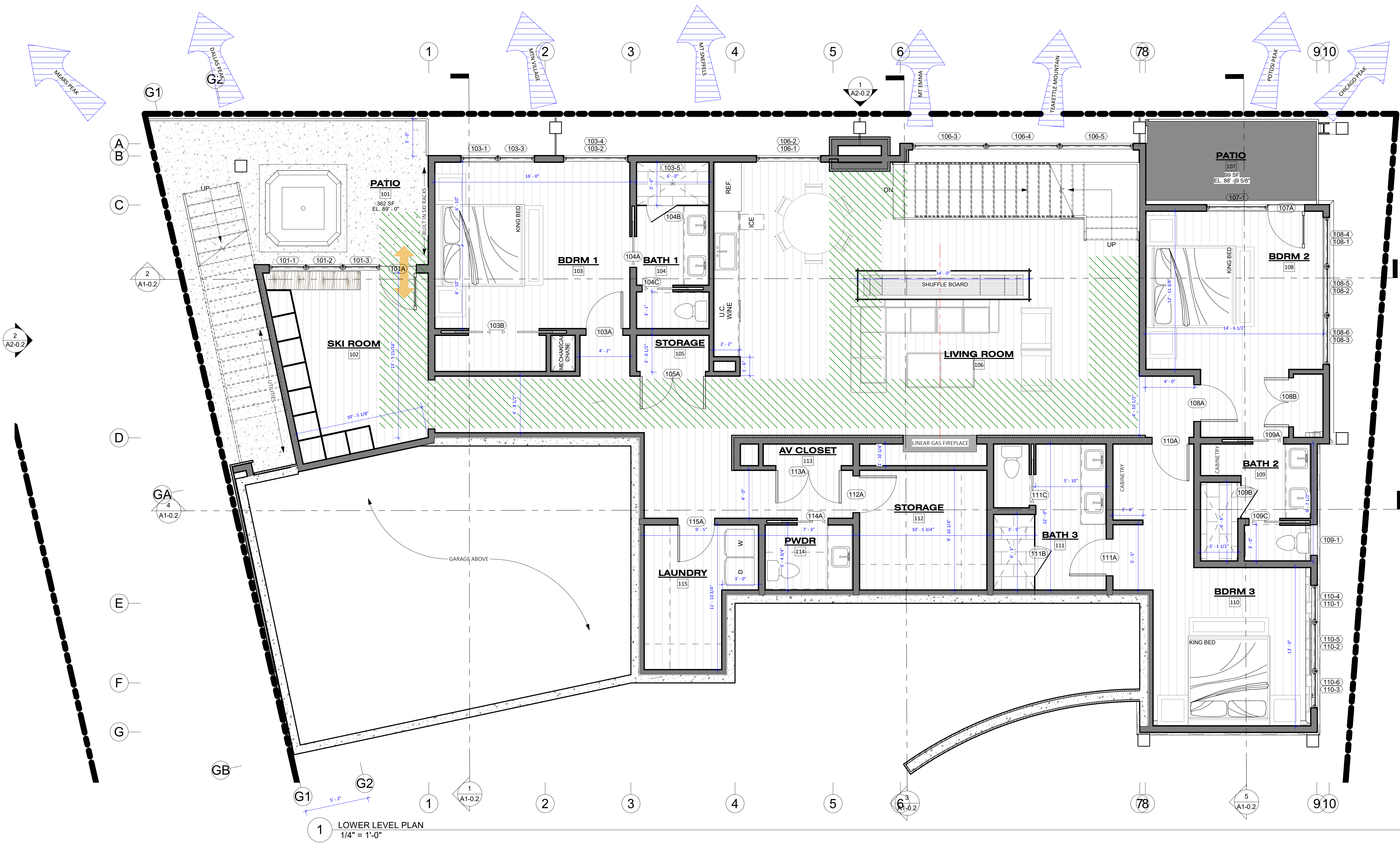

1 LOWER LEVEL PLAN  
1/4" = 1'-0"

PROJECT SQUARE FOOTAGE		
LEVEL	NAME	AREA
T.O. ROCK BOTTOM	LIVING	1416 SF
T.O. SLAB	LIVING	2828 SF
T.O. SUB FLR	LIVING	2447 SF
HABITABLE		6692 SF
T.O. ROCK BOTTOM	MECH	300 SF
T.O. SUB FLR	GARAGE	659 SF
NON HABITABLE		958 SF
GROSS AREA		7651 SF

FLOOR PLAN LEGEND	
	CENTERLINE
	AUTOMATIC BLIND- SHEER
	AUTOMATIC BLIND- BLACK OUT
	ACCENT DRAPE
	ARCHITECTURAL WALL
	CONVENTIONAL WOOD FRAMING - STANDARD THICKNESS 2x6 U.N.O.
	CONCRETE WALL - STANDARD THICKNESS 8" U.N.O.
	STONE MASONRY - STANDARD THICKNESS OF 1 1/2" U.N.O.
	INDICATES COLUMN. VERIFY SIZE AND TYPE WITH STRUCTURAL DRAWINGS TYP.
	SNOW SHED

- GENERAL NOTES:**
- ALL DIMENSIONS ARE TO FRAMING UNLESS NOTED OTHERWISE.
  - ALL WOOD FRAMED FLOORS TO RECEIVE 1 1/2" L.W. GYPSUM CONCRETE LAYER WITH EMBEDDED RADIANT HEAT TUBING U.N.O. ALL CONC. SLAB FLOORING SHALL HAVE IMBEDDED RADIANT HEAT TUBING U.N.O. REFERENCE MECHANICAL CONTRACTOR FOR FURTHER INFORMATION.
  - CENTER ALL DOORS ABOUT WALL OR SPACE UNLESS INDICATED OTHERWISE.
  - ALL BARN DOOR OPENINGS SHALL BE GYW CASED OPENINGS AND SHALL HAVE A CLEAR OPENING 2" LESS THAT OF THE DOOR PANEL WIDTH (TYP. U.N.O.).
  - THE GENERAL CONTRACTOR AND/OR WINDOW MANUFACTURER/SUPPLIER SHALL BE RESPONSIBLE FOR ENSURING THAT SAFETY GLASS IS PROVIDED WHERE APPLICABLE IN ACCORDANCE WITH 2012 IRC SECTION R308.4.
  - RADON MITIGATION SYSTEM SHALL BE INSTALLED UNDER ALL CONCRETE SLABS. (TYP)
  - ANY AND ALL POST AND BEAM SIZES SHALL BE CROSS CHECKED WITH STRUCTURAL DRAWINGS, NOTIFY ARCHITECT OF ANY DISCREPANCIES. (TYP)
  - WATER SUPPLY (W.S.) TO BE LOCATED ON NON-VISIBLE SIDE OF TOILET (TYP)
  - MATERIAL TRANSITION TO FALL BELOW DOOR LEAF (TYP)
  - STAIR WALLS SHALL BE FRAMED WITH LVL'S
  - ANY WALL SUPPORTING FLOATING SHELVING SHALL BE FRAMED WITH LVL'S
  - HOT TUB COORD. WITH OWNER ON MFR, SIZE, MECH ACCESS, COVER LOCATION WHEN OPEN AND CONFIRM SIZE OF RECESSED OPENING.

Issued For	Date
100% S.D.	01/14/2021
Pricing #	-
ARC Sketch Review	01/14/2021
100% D.D.	-
ARC Final Review	-
100% C.D.	-
REV. #	-

Drawn By S. D'AGOSTINO  
Date 01/14/2021  
Project # 2021.00  
Phase SD  
Sheet



**COLORADO:**  
10125 RANCHO MONTECITO  
DR. PARKER, COLORADO 80138  
P.303.840.0020

**MONTANA:**  
P.O. BOX 161488  
11 LONE PEAK DR., UNIT 206  
BIG SKY, MONTANA 59716  
P.406.995.7572

**UTAH:**  
1960 SIDEWINDER DR., #101  
PARK CITY, UTAH 84060  
P.435.604.0891

www.centresky.com

TELLURIDE #6  
TELLURIDE, CO 81435

NOT FOR  
CONSTRUCTION

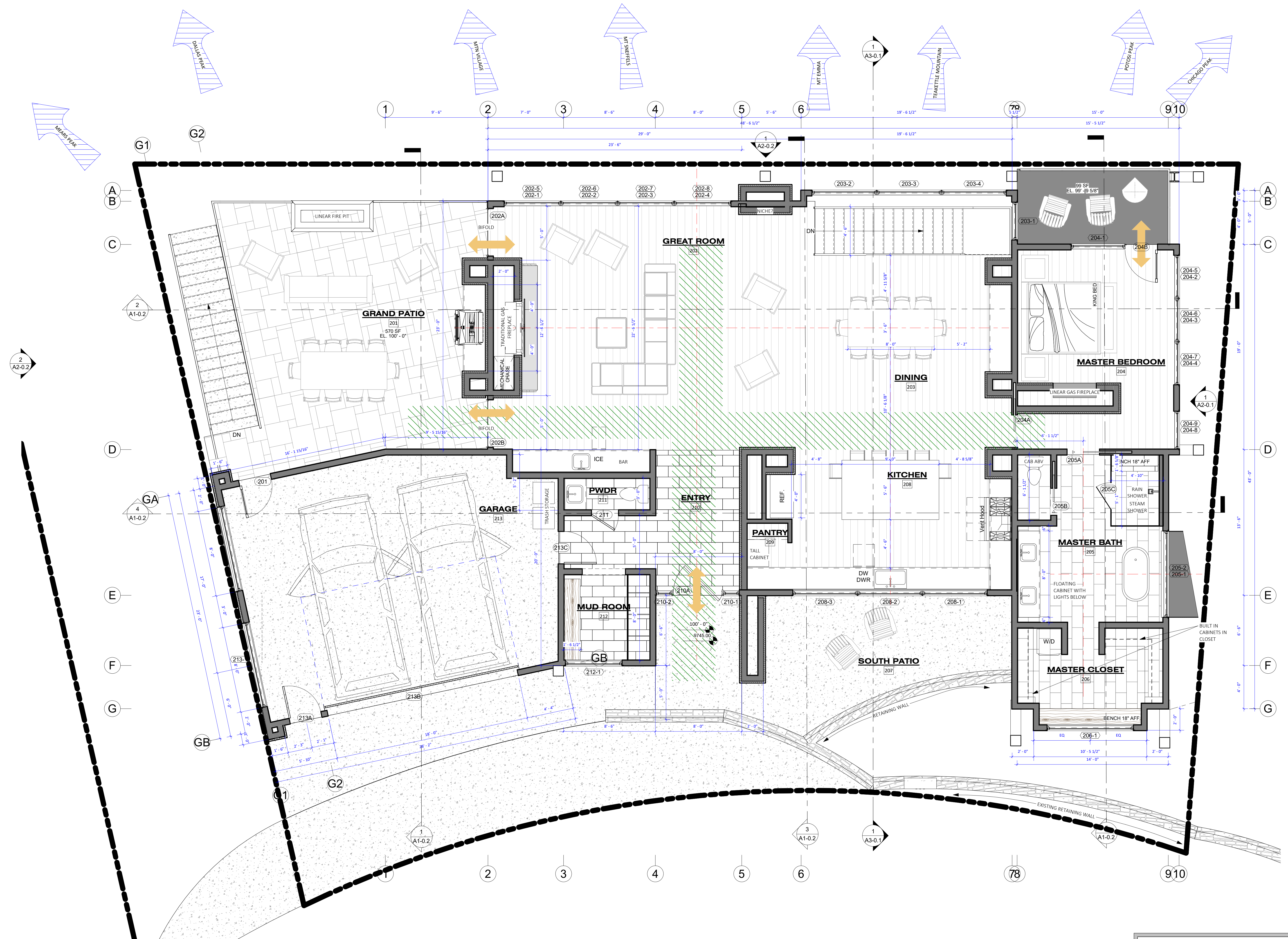

1 MAIN LEVEL PLAN  
1/4" = 1'-0"

LEVEL	NAME	AREA
T.O. ROCK BOTTOM	LIVING	1416 SF
T.O. SLAB	LIVING	2829 SF
T.O. SUB FLR	LIVING	2447 SF
HABITABLE		6692 SF
T.O. ROCK BOTTOM	MECH	300 SF
T.O. SUB FLR	GARAGE	659 SF
NON HABITABLE		958 SF
GROSS AREA		7651 SF

FLOOR PLAN LEGEND	
	CENTERLINE
	AUTOMATIC BLIND: SHEER
	AUTOMATIC BLIND: BLACK OUT
	ACCENT DRAPE
	ARCHITECTURAL WALL
	CONVENTIONAL WOOD FRAMING - STANDARD THICKNESS 2x6 U.N.O.
	CONCRETE WALL - STANDARD THICKNESS 8" U.N.O.
	STONE MASONRY - STANDARD THICKNESS OF 1 1/2" U.N.O.
	INDICATES COLUMN VERIFY SIZE AND TYPE WITH STRUCTURAL DRAWINGS TYP.
	SNOW SHED

- GENERAL NOTES:**
- ALL DIMENSIONS ARE TO FRAMING UNLESS NOTED OTHERWISE.
  - ALL WOOD FRAMED FLOORS TO RECEIVE 1 1/2" L.W. GYPSUM CONCRETE LAYER WITH EMBEDDED RADIANT HEAT TUBING U.N.O. ALL CONC. SLAB FLOORING SHALL HAVE IMBEDDED RADIANT HEAT TUBING U.N.O. - REFERENCE MECHANICAL CONTRACTOR FOR FURTHER INFORMATION.
  - CENTER ALL DOORS ABOUT WALL OR SPACE UNLESS INDICATED OTHERWISE.
  - ALL BARN DOOR OPENINGS SHALL BE GWB CASED OPENINGS AND SHALL HAVE A CLEAR OPENING 2" LESS THAT OF THE DOOR PANEL WIDTH (TYP. U.N.O.)
  - THE GENERAL CONTRACTOR AND/OR WINDOW MANUFACTURER/SUPPLIER SHALL BE RESPONSIBLE FOR ENSURING THAT SAFETY GLASS IS PROVIDED WHERE APPLICABLE IN ACCORDANCE WITH 2012 IRC SECTION R808.4
  - RADON MITIGATION SYSTEM SHALL BE INSTALLED UNDER ALL CONCRETE SLABS. (TYP)
  - ANY AND ALL POST AND BEAM SIZES SHALL BE CROSS CHECKED WITH STRUCTURAL DRAWINGS, NOTIFY ARCHITECT OF ANY DISCREPANCIES. (TYP)
  - WATER SUPPLY (W.S.) TO BE LOCATED ON NON-VISIBLE SIDE OF TOILET (TYP)
  - MATERIAL TRANSITION TO FALL BELOW DOOR LEAF (TYP)
  - STAR WALLS SHALL BE FRAMED WITH LVLS
  - ANY WALL SUPPORTING FLOATING SHELVING SHALL BE FRAMED WITH LVLS
  - HOT TUB COORD. WITH OWNER ON MFR, SIZE, MECH ACCESS, COVER LOCATION WHEN OPEN AND CONFIRM SIZE OF RECESSED OPENING.

Issued For	Date
100% S.D.	01/14/2021
Pricing #	-
ARC Sketch Review	01/14/2021
100% D.D.	-
ARC Final Review	-
100% C.D.	-
REV. #	-

Drawn By S. D'AGOSTINO  
Date 01/14/2021  
Project # 2021.00  
Phase SD  
Sheet

A1-1.1  
MAIN LEVEL PLAN



**COLORADO:**  
 10125 RANCHO MONTECITO  
 DR. PARKER, COLORADO 80138  
 P.303.840.0020

**MONTANA:**  
 P.O. BOX 161488  
 11 LONE PEAK DR., UNIT 206  
 BIG SKY, MONTANA 59716  
 P.406.995.7572

**UTAH:**  
 1960 SIDEWINDER DR., #101  
 PARK CITY, UTAH 84060  
 P.435.604.0891

www.centresky.com

TELLURIDE #6  
 TELLURIDE, CO 81435

NOT FOR  
 CONSTRUCTION



Issued For	Date
100% S.D.	01/14/2021
Pricing #	-
ARC Sketch Review	01/14/2021
100% D.D.	-
ARC Final Review	-
100% C.D.	-
REV. #	-

Drawn By S. D'AGOSTINO  
 Date 01/14/2021  
 Project # 2021.00  
 Phase SD  
 Sheet

A1-3.1  
 ROOF PLAN

ROOF SLOPE	H
12 : 12	1/2 OF W
8 : 12	3/4 OF W
6 : 12	1 1/4 OF W
4 : 12	1 3/4 OF W
3 : 12	1 7/8 OF W

**ROOF PLAN LEGEND**

NOTE:  
 REFER TO PROJECT SPECIFICATIONS FOR FURTHER INFORMATION ON MATERIAL TYPES AND INSTALLATION REQUIREMENTS

**METAL ROOFING**  
 STANDING SEAM, 2" MECH. RIB WITH STRIATIONS & MASTIC, 16" RIB SPACING  
 COLOR: SLATE GREY RAWHIDE  
 MFR: TBD

**BALLAST ROOFING**  
 TPO ROOF WITH RIVER ROCK BALLAST  
 COLOR: GREY MIX

● METAL TYPE A, SEAMLESS 6" SQUARE, DARK BRONZE, GUTTERS W/ DOWNSPOUT AS INDICATED. PROVIDE ELEC. HEAT TAPE, TYP.  
 ■ PROVIDE DEBRIS SCREEN AT ALL TRANSITIONS TO DOWNSPOUT, TYP.

— FASCIA TYPE A, RE: ROOF DETAILS  
 — FASCIA TYPE B, RE: ROOF DETAILS

■ SNOW SHED LOCATION

**ROOF PLAN GENERAL NOTES**

- ALL ROOFS TO ACHIEVE A CLASS 'A' FIRE RATING BY INSTALLING REQUIRED ROOFING UNDERLAYMENT AT ALL LOCATIONS WHERE PRIMARY ROOF MATERIAL DOES NOT ACHIEVE CLASS 'A' RATING. GC TO VERIFY COMPLIANCE, TYP.
- ALL RAKE AND EAVE DIMENSIONS TO BE HORIZONTAL DIMENSIONS, NOT ALONG THE PITCH.
- COORDINATE LAYOUT OF ROOF FRAMING WITH EXPOSED RAFTERS WHERE APPLICABLE. SEE REFLECTED CEILING PLAN FOR LOCATIONS, (TYP.)
- PROVIDE ELEC. ROUGH IN FOR HEAT TAPE IN ALL VALLEYS, RE: ELEC. FOR FURTHER DETAIL.
- VERIFY ALL GUTTER & DOWNSPOUT LOCATIONS AND TYPES WITH ARCHITECT PRIOR TO INSTALLATION.
- LIGHTNING PROTECTION IS RECOMMENDED. REFER TO MANUFACTURER FOR LIGHTNING ROD AND GROUND ROD LOCATIONS AS IMPLEMENTED.
- PROVIDE ELECTRICAL HEAT TAPE AT ALL HARD PIPED GUTTERS & DOWNSPOUTS (TYP.)
- ALL ROOF PENETRATION LOCATIONS INCLUDING, BUT NOT LIMITED TO; FLUES, VENTILATION PIPES AND STACKS SHALL BE SUBMITTED TO ARCHITECT AND ROOFING MFR. FOR REVIEW. (NOTE: NOT ALL ROOF PENETRATIONS MAY BE SHOWN ON PLAN)
- DIVERTER FLASHING SHALL BE INSTALLED WHERE A LOWER SLOPED ROOF TERMINATES AGAINST A VERTICAL WALL, CHIMNEY CHASE, OR FRAMED COLUMN.
- FLASHING AT PLUMBING VENTS TO MATCH ROOF MATERIAL, RE:
- GENERAL CONTRACTOR TO COORDINATE ALL SUBS THAT WILL PERFORM WORK ON OR MANIPULATE WORK OF THE ROOF. ANY CUTTING, PATCHING, DRILLING, SCREW PENETRATION AND PROTECTION NEED TO BE COORDINATED WITH THE ROOFER. 6/A1-3.4

**METAL ROOFS:** INSTALL SLIP SHEET AS SPECIFIED ON TOP OF SINGLE LAYER "MIRADRI" HIGH TEMP. ICE & WATER UNDERLAYMENT. DUAL LAYER TO EXTEND 6" UP FROM BOTTOM ON LOW SLOPE ROOFS. COVER ALL PWD SHEATHING WHERE METAL ROOF IS LOCATED. LAP OVER HIP, RIDGES, AND THROUGH VALLEYS, TYP. UNDERLAYMENT SHALL BE LAPPED 6" VERTICALLY (END OR SIDE LAP) AND 2" HORIZONTALLY (HEAD LAP).

**SHINGLE ROOFS:** INSTALL SINGLE LAYER OF SLOPESHIELD OVER "MIRADRI" ICE & WATER UNDERLAYMENT OR EQ. TO COVER ALL PWD SHEATHING WHERE SHINGLE ROOFS ARE LOCATED. LAP OVER HIP, RIDGES, AND THROUGH VALLEYS, TYP. UNDERLAYMENT SHALL BE LAPPED 6" VERTICALLY (END OR SIDE LAP) AND 2" HORIZONTALLY (HEAD LAP). INSTALL SINGLE LAYER OF 5/8 MIN. FELT PAPER AT EVERY COARSE SHINGLE COARSE, TYP.

ALL HIP AND RIDGES TO RECEIVE "PROTECTO WRAP" HIP AND RIDGE SEAL AS SPECIFIED, TYP.

NOTE: ALL VALLEYS TO RECEIVE METAL TYPE 'A' W-VALLEY METAL OVER TOP SLIP SHEET AS SPECIFIED 6" EXPOSED VALLEY METAL EACH SIDE, TYP.

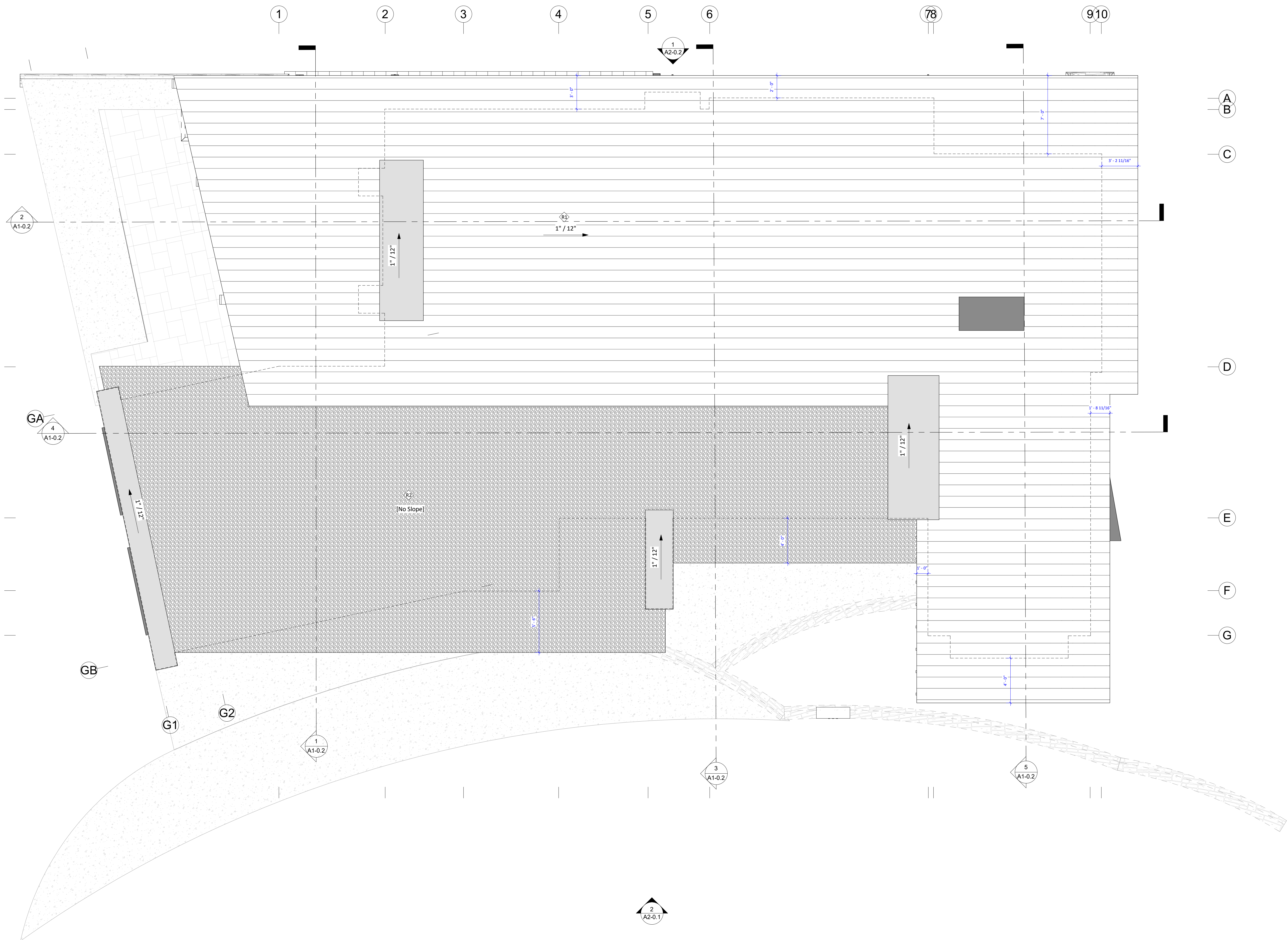



**COLORADO:**  
 10125 RANCHO MONTECITO  
 DR. PARKER, COLORADO 80138  
 P.303.840.0020

**MONTANA:**  
 P.O. BOX 161488  
 11 LONE PEAK DR., UNIT 206  
 BIG SKY, MONTANA 59716  
 P.406.995.7572

**UTAH:**  
 1960 SIDEWINDER DR., #101  
 PARK CITY, UTAH 84060  
 P.435.604.0891

www.centresky.com



TELLURIDE #6  
 TELLURIDE, CO 81435

NOT FOR  
 CONSTRUCTION



Issued For	Date
• 100% S.D.	01/14/2021
• Pricing #	-
• ARC Sketch Review	01/14/2021
• 100% D.D.	-
• ARC Final Review	-
• 100% C.D.	-
• REV. #	-

Drawn By: Author  
 Date: 01/14/2021  
 Project #: 2021.00  
 Phase: SD  
 Sheet

**A1-3.2**  
 ROOF PLAN & TOPO  
 SURVEY

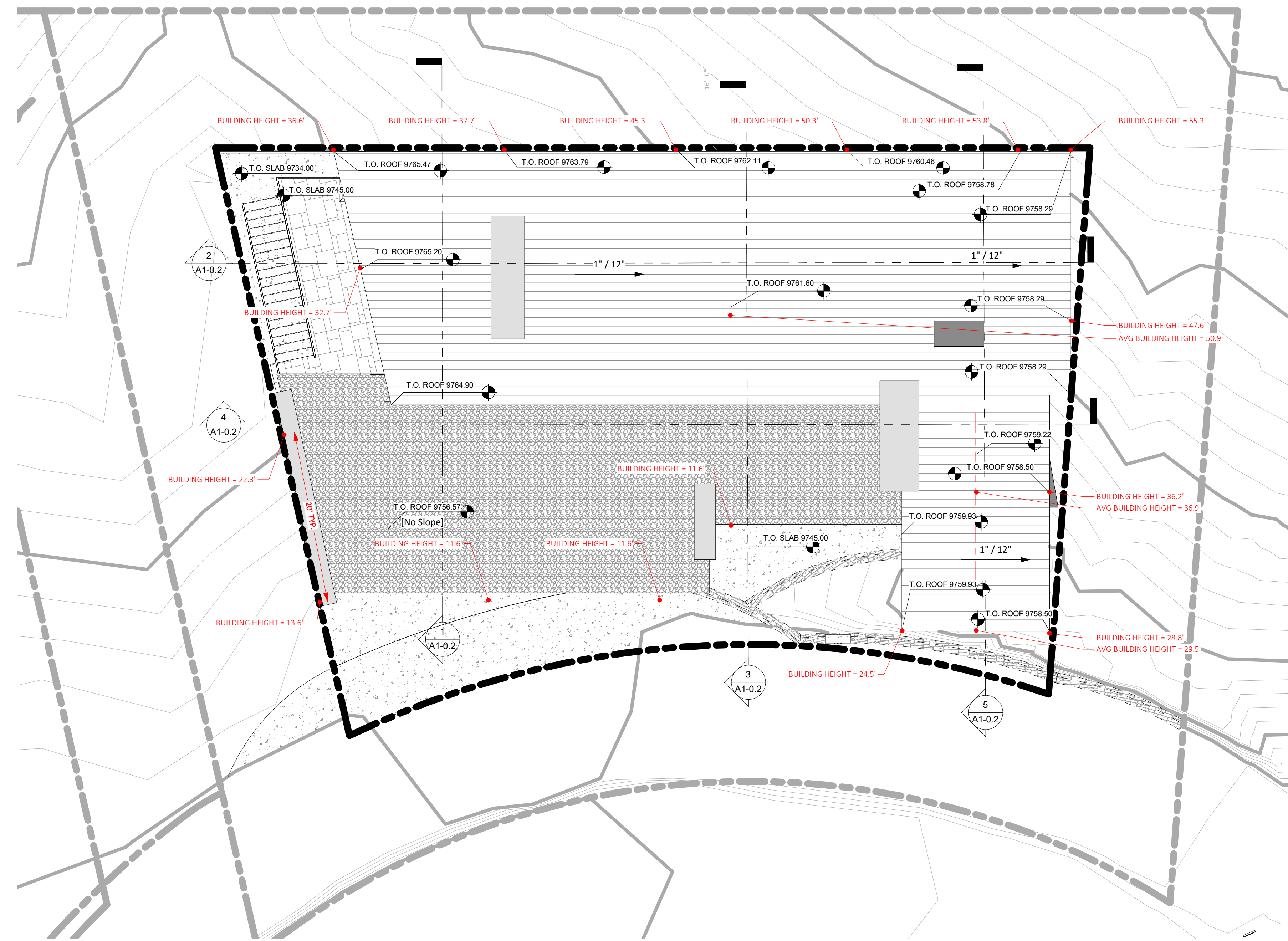

**1** ROOF PLAN  
 1/8" = 1'-0"

**LOT COVERAGE - MOUNTAIN VILLAGE DEFINITION**

LOT COVERAGE: THE CALCULATION OF THE TOTAL HORIZONTAL AREA OF ANY BUILDING, CARPORT, PORTE, COCHERE, OR ARCADE AND SHALL ALSO INCLUDE WALKWAYS, ROOF OVERHANGS, EAVES, EXTERIOR STAIRS, DECKS, COVERED PORCH, TERRACES AND PATIOS. SUCH HORIZONTAL MEASUREMENT SHALL BE FROM THE BUILDING DRIP LINES AND FROM THE EXTERIOR SURFACE OF THE TOTAL WALL ASSEMBLY, WHICHEVER IS MORE RESTRICTIVE.

LOT COVERAGE = 4,738 SF  
 LOT SIZE = 11,972 SF  
 LOT COVERAGE = 39.5%

MAXIMUM LOT COVERAGE ALLOWED = 40%

**AVERAGE ROOF HEIGHT - MOUNTAIN VILLAGE DEFINITION**

MAXIMUM AVERAGE HEIGHT SHALL BE MEASURED FROM THE FINISHED GRADE TO A POINT ON THE ROOF PLANE MIDWAY BETWEEN THE EAVE & THE RIDGE.  
 ON COMPLEX BUILDINGS WITH MULTIPLE HEIGHTS AND/OR BUILDINGS WITH MULTIPLE HEIGHTS ON SLOPING SITES, THE MAXIMUM AVERAGE HEIGHT SHALL BE DETERMINED BY TAKING THE AVERAGE OF HEIGHTS AT EQUAL INTERVALS AROUND THE PERIMETER OF A BUILDING. THOSE INTERVALS SHALL BE NO MORE THAN 20 FEET.

AVERAGE BUILDING HEIGHTS AT 20' MAX INTERVALS:  
 13.6 + 22.3 + 32.7 + 36.6 + 37.7 + 45.3 + 50.3 + 53.8 + 56.3 + 50.9 + 36.9 + 29.5 + 24.5 + 11.6 + 11.6 + 11.6 = 529.2 / 16 = 32.8

**AVERAGE BUILDING HEIGHT = 32.8'**

**MAX BUILDING HEIGHT - MOUNTAIN VILLAGE DEFINITION**

BUILDING HEIGHT SHALL BE MEASURED VERTICALLY AT A RIGHT ANGLE TO THE HORIZON LINE FROM ANY POINT ON A PROPOSED OR EXISTING ROOF OR EAVE (INCLUDING BUT NOT LIMITED TO THE ROOFING MEMBRANE) TO THE NATURAL GRADE OR FINISHED GRADE, WHICHEVER IS MORE RESTRICTIVE, LOCATED DIRECTLY BELOW SAID POINT OF THE ROOF OR EAVES.

**MAX BUILDING HEIGHT = 55.33' (VARIANCE REQUESTED)**



**COLORADO:**  
 10125 RANCHO MONTECITO  
 DR. PARKER, COLORADO 80138  
 P.303.840.0020

**MONTANA:**  
 P.O. BOX 161488  
 11 LONE PEAK DR., UNIT 206  
 BIG SKY, MONTANA 59716  
 P.406.995.7572

**UTAH:**  
 1960 SIDEWINDER DR., #101  
 PARK CITY, UTAH 84060  
 P.435.604.0891

www.centresky.com

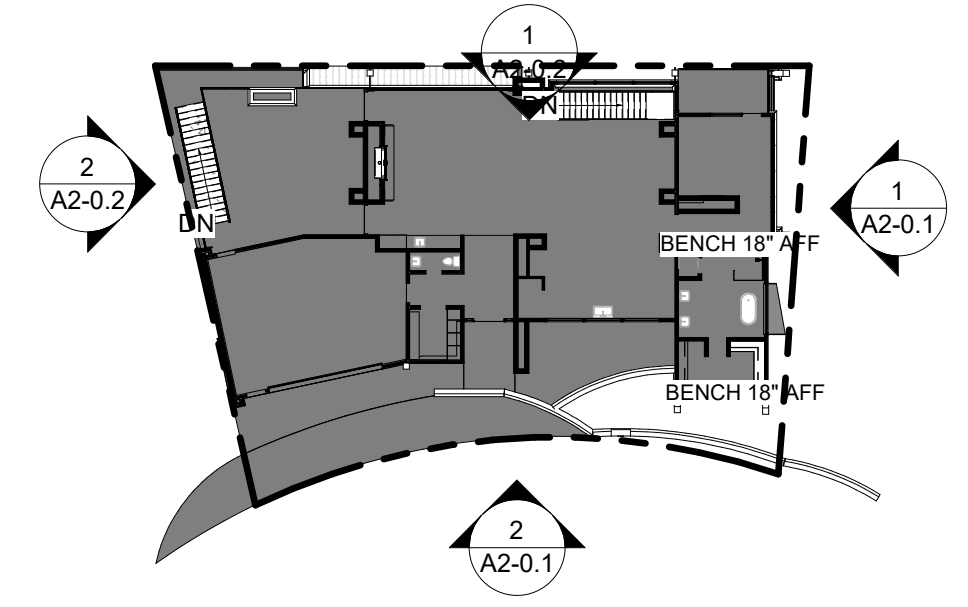

**3** KEY PLAN  
 1" = 30'-0"

EXTERIOR MATERIALS LEGEND	
<b>NOTE:</b> REFER TO PROJECT SPECIFICATIONS FOR FURTHER INFORMATION ON MATERIAL TYPES AND INSTALLATION REQUIREMENTS.	
	<b>METAL ROOFING</b> STANDING SEAM, 2" MECH. RIB WITH STRIPATIONS & MASTIC, 16" RIB SPACING COLOR: SLATE GREY RAWHIDE MFR: TBD
	<b>BALLAST ROOFING</b> EPDM ROOF WITH RIVER ROCK BALLAST COLOR: GREY MIX
	<b>HORIZONTAL WOOD SIDING</b> 2X10 RECLAIMED WOOD BOARD RAINSCREEN, HORIZONTAL WITH 1" SPACING COLOR: VARIED GREY MFR: MRL RE: 1/ AS-1.2
	<b>STONE MASONRY VENEER</b> NATURAL RECTANGULAR CUT DEEP CREEK 1 1/2" VENEER LAYUP: RE: 2/ AS-1.2
	<b>STEEL SIDING</b> PATINATED STEEL SIDING PANELS, 1/8" W/EXPOSED FASTENERS, SEE ELEVATIONS FOR SEAM SPACING PATINA: VARIED BROWN/BLACK MFR: TBD RE: 3/ AS-1.2

MATERIAL	ELEVATION (SF/%)				
	NORTH	EAST	SOUTH	WEST	TOTAL
STONE	1180/28.9	946/42.1	211/17.4	852/57.8	3,189/35.4
METAL	507/12.4	431/19	494/16.8	90/6.1	1,522/16.9
WOOD	467/11.4	434/19.3	203/25	371/25.2	1,475/16.4
FENESTRATION	1929/47.2	441/19.6	302/40.1	161/10.9	2,833/31.4

TELLURIDE #6  
 TELLURIDE, CO 81435

NOT FOR  
 CONSTRUCTION



Issued For	Date
• 100% S.D.	01/14/2021
• Pricing #	-
• ARC Sketch Review	01/14/2021
• 100% D.D.	-
• ARC Final Review	-
• 100% C.D.	-
• REV. #	-

Drawn By S. D'AGOSTINO  
 Date 01/14/2021  
 Project # 2021.00  
 Phase SD  
 Sheet

**A2-0.1**  
 EXTERIOR  
 ELEVATIONS

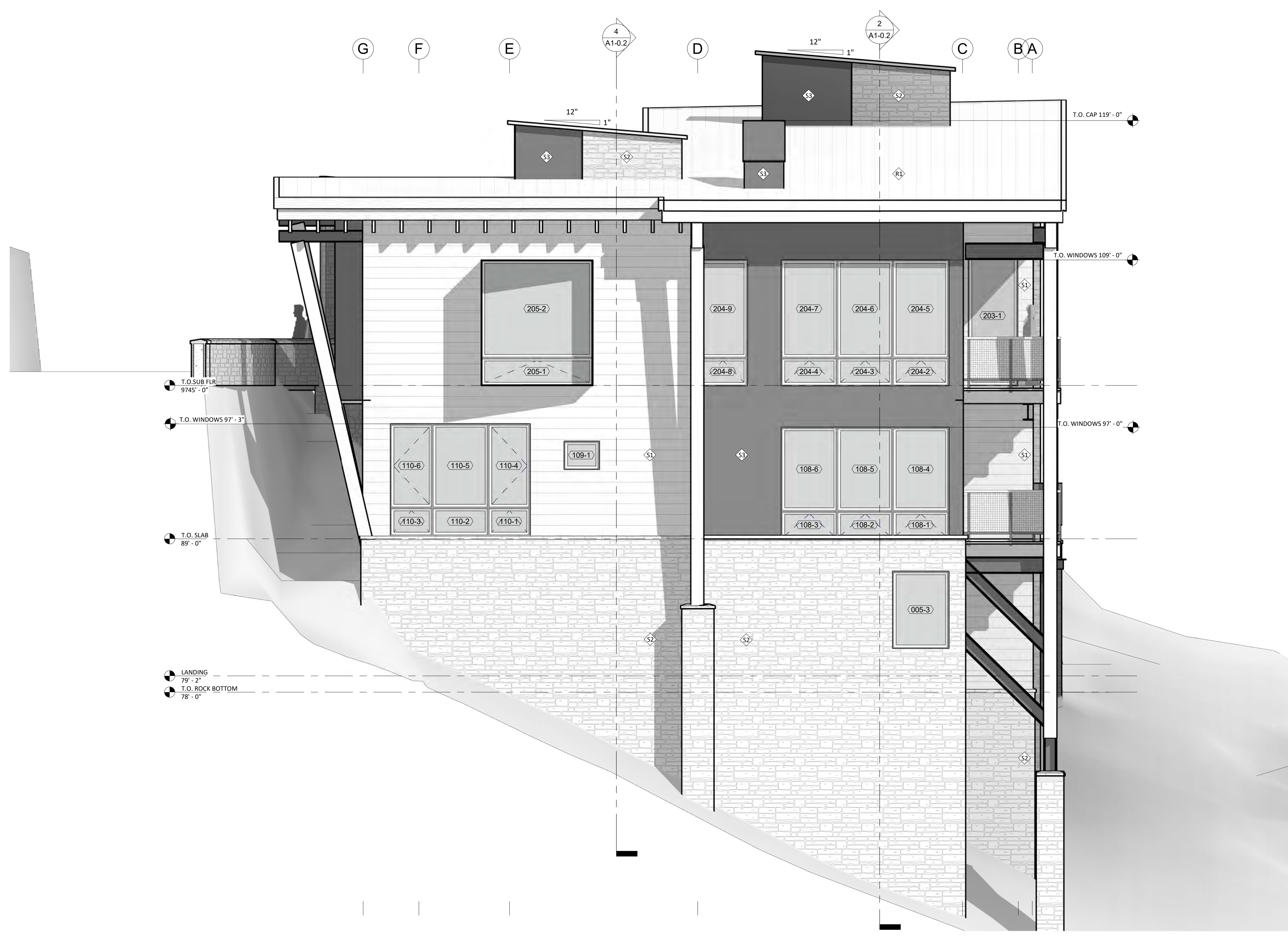

**1** EAST  
 1/4" = 1'-0"

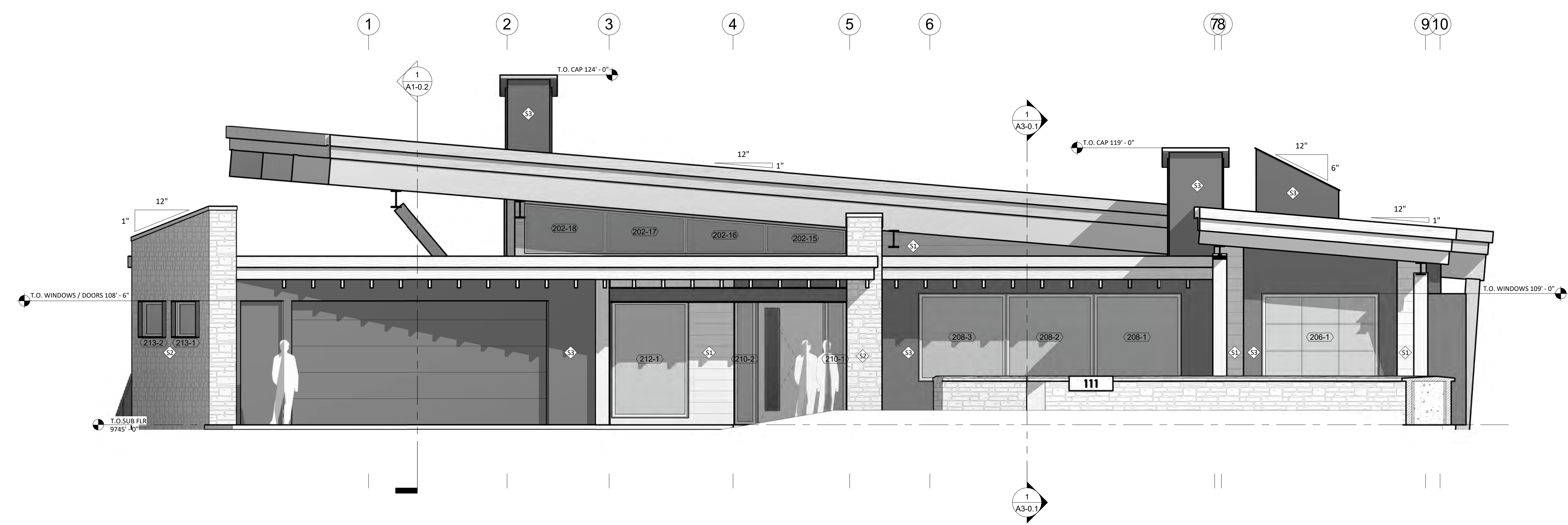

**2** SOUTH  
 1/4" = 1'-0"

**CENTRE SKY**

ARCHITECTURE, LTD.  
ARCHITECTURE  
&  
PLANNING



**COLORADO:**  
10125 RANCHO MONTECITO  
DR. PARKER, COLORADO 80138  
P 303.840.0020

**MONTANA:**  
P.O. BOX 161488  
11 LONE PEAK DR., UNIT 206  
BIG SKY, MONTANA 59716  
P 406.995.7572

**UTAH:**  
1960 SIDERWINDER DR., #101  
PARK CITY, UTAH 84060  
P 435.604.0891

www.centresky.com

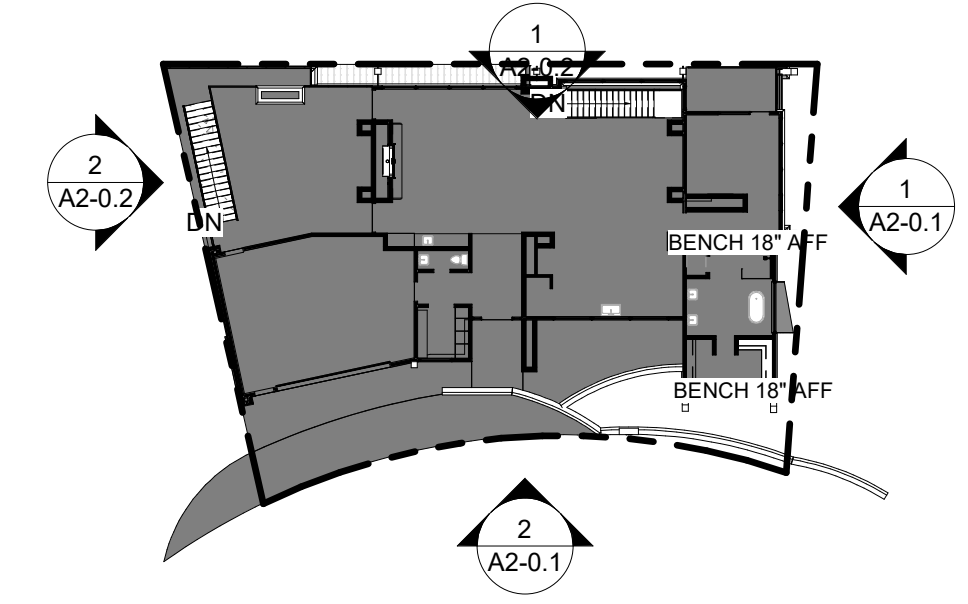

3 KEY PLAN  
1" = 30'-0"

**EXTERIOR MATERIALS LEGEND**

NOTE:  
REFER TO PROJECT SPECIFICATIONS FOR FURTHER INFORMATION ON MATERIAL TYPES AND INSTALLATION REQUIREMENTS.

	<b>METAL ROOFING</b> STANDING SEAM, 2" MECH. RIB WITH STRUTS & MASTIC, 16" RIB SPACING COLOR: SLATE GREY RAWHIDE MFR: TBD
	<b>BALLAST ROOFING</b> EPDM ROOF WITH RIVER ROCK BALLAST COLOR: GREY MIX
	<b>HORIZONTAL WOOD SIDING</b> 2x10 RECLAIMED WOOD BOARD RAINSCREEN, HORIZONTAL WITH 3" SPACING COLOR: VARIED GREY MFR: MRL RE: 1/A5-1.2
	<b>STONE MASONRY VENEER</b> NATURAL RECTANGULAR CUT DEEP CREEK 1 1/2" VENEER LAYOUT RE: 2/A5-1.2
	<b>STEEL SIDING</b> PATINATED STEEL SIDING PANELS, 1/8" W/EXPOSED FASTENERS, SEE ELEVATIONS FOR SEAM SPACING PATINA: VARIED BROWN/BLACK MFR: TBD RE: 3/A5-1.2

**EXTERIOR MATERIAL QUANTITIES**

MATERIAL	ELEVATION (SF/%)					TOTAL
	NORTH	EAST	SOUTH	WEST		
STONE	1380/28.9	946/42.1	211/17.4	852/57.8		3,189/35.4
METAL	507/12.4	431/19	494/16.8	90/6.1		1,522/16.9
WOOD	467/11.4	434/19.3	203/25	371/25.2		1,475/16.4
FENESTRATION	1929/47.2	441/19.6	302/40.1	161/10.9		2,833/31.4

TELLURIDE #6  
TELLURIDE, CO 81435

NOT FOR  
CONSTRUCTION

Issued For	Date
• 100% S.D.	01/14/2021
• Pricing #	-
• ARC Sketch Review	01/14/2021
• 100% D.D.	-
• ARC Final Review	-
• 100% C.D.	-
• REV. #	-

Drawn By S. D'AGOSTINO  
Date 01/14/2021  
Project # 2021.00  
Phase SD  
Sheet

A2-0.2  
EXTERIOR  
ELEVATIONS



1 NORTH  
1/4" = 1'-0"

2 WEST  
1/4" = 1'-0"





**COLORADO:**  
 10125 RANCHO MONTECITO  
 DR. PARKER, COLORADO 80138  
 P.303.840.0020

**MONTANA:**  
 P.O. BOX 161488  
 11 LONE PEAK DR., UNIT 206  
 BIG SKY, MONTANA 59716  
 P.406.995.7572

**UTAH:**  
 1960 SIDEWINDER DR., #101  
 PARK CITY, UTAH 84060  
 P.435.604.0891

www.centresky.com

TELLURIDE #6  
 TELLURIDE, CO 81435

NOT FOR  
 CONSTRUCTION



Issued For	Date
• 100% S.D.	01/14/2021
• Pricing #	-
• ARC Sketch Review	01/14/2021
• 100% D.D.	-
• ARC Final Review	-
• 100% C.D.	-
• REV. #	-

Drawn By S. D'AGOSTINO  
 Date 01/14/2021  
 Project # 2021.00  
 Phase SD  
 Sheet

**A5-1.2**  
 EXTERIOR DETAILS

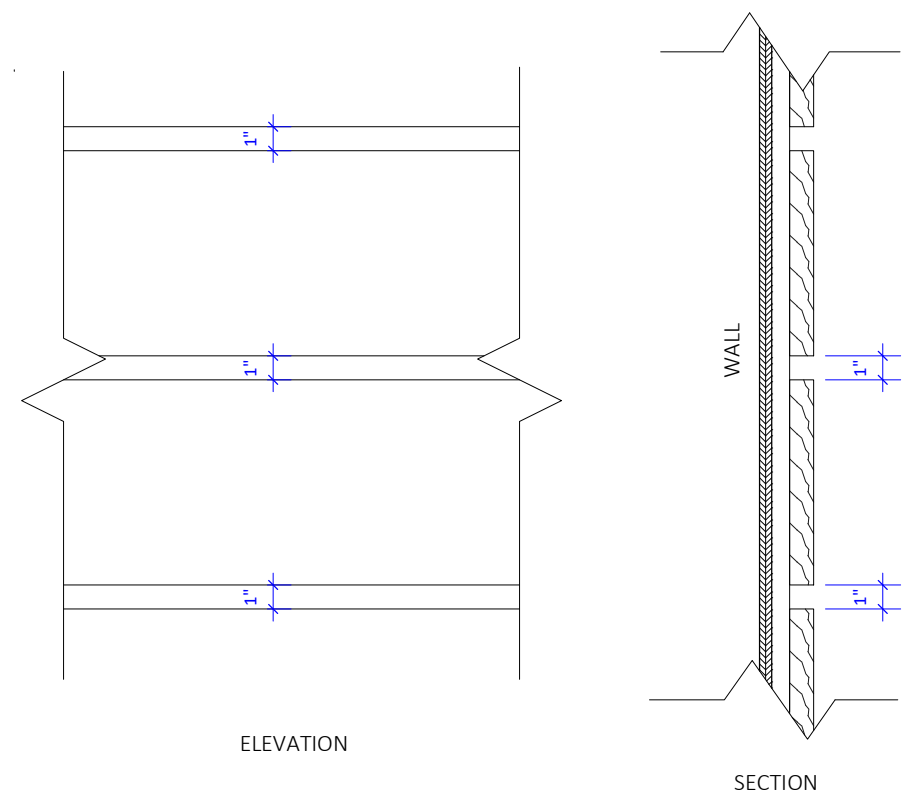

**1 SQUARE EDGE PROFILE**  
 1 1/2" = 1'-0"

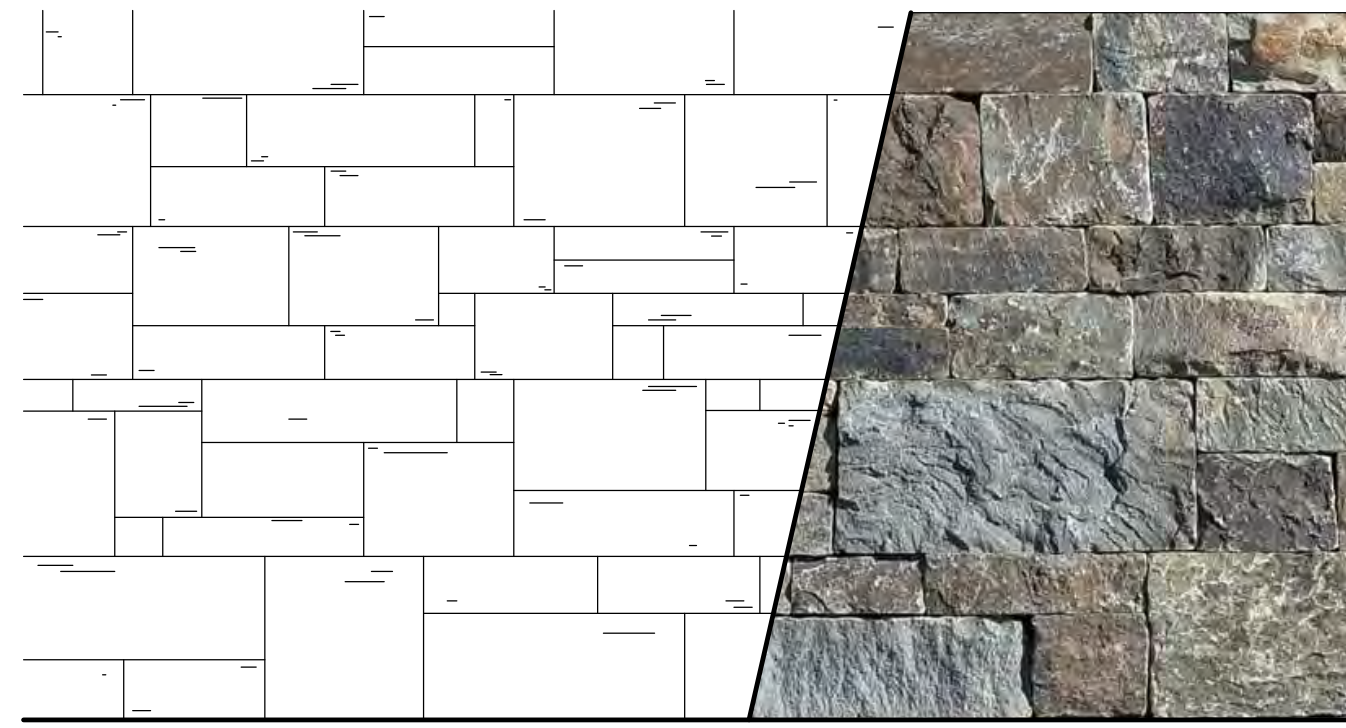

DEEP CREEK LAYUP

**2 STONE LAYUP DETAIL - DEEP CREEK**  
 3/4" = 1'-0"

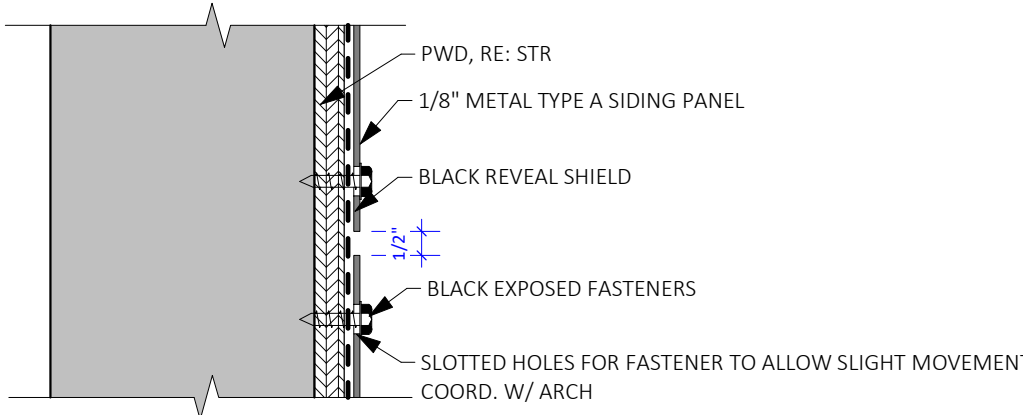

**3 STEEL SIDING DETAIL**  
 3/4" = 1'-0"

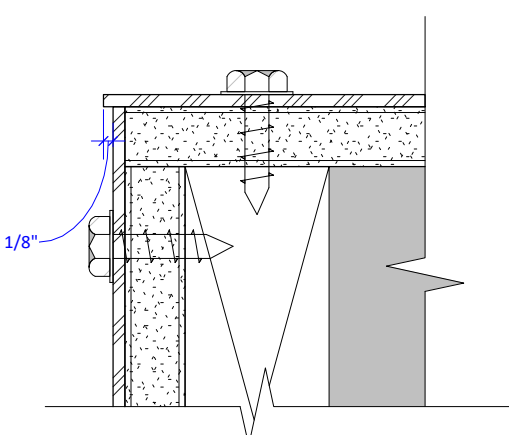

**4 STEEL CORNER DETAIL TYP.**  
 6" = 1'-0"

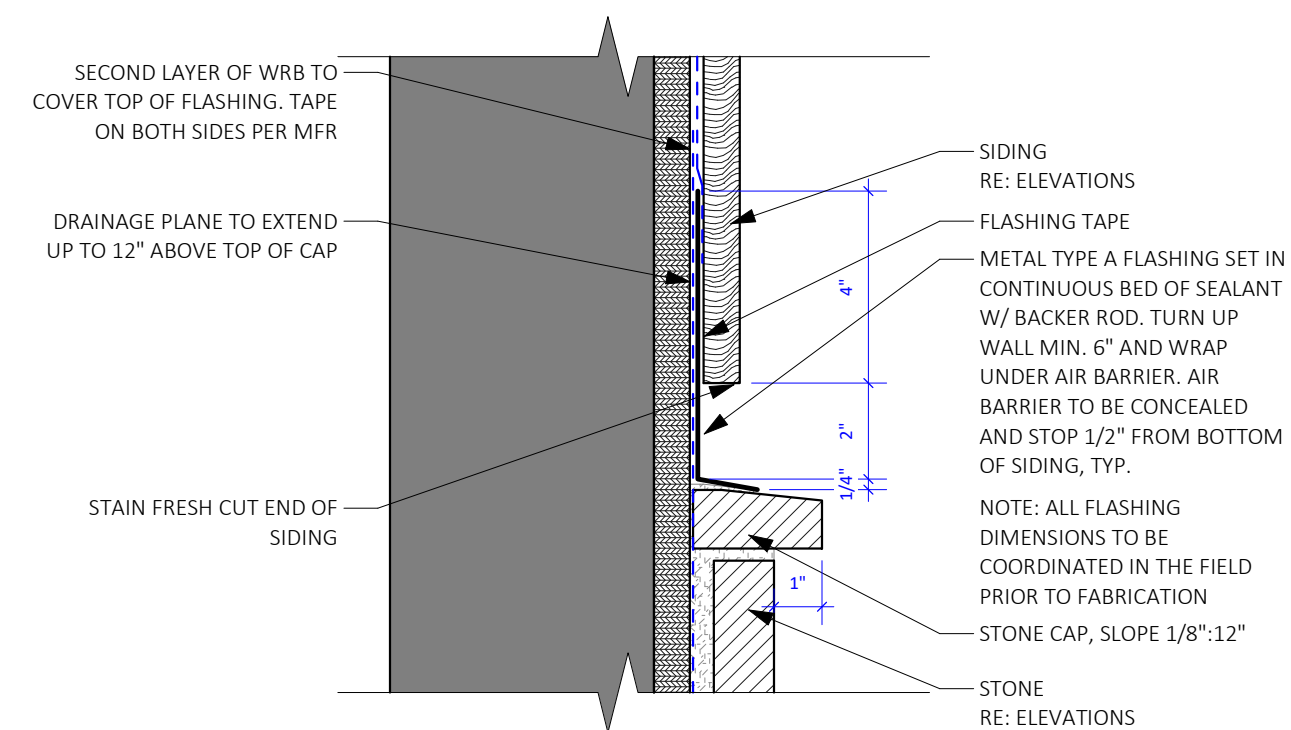

**5 TYP. STONE SILL DETAIL**  
 3" = 1'-0"

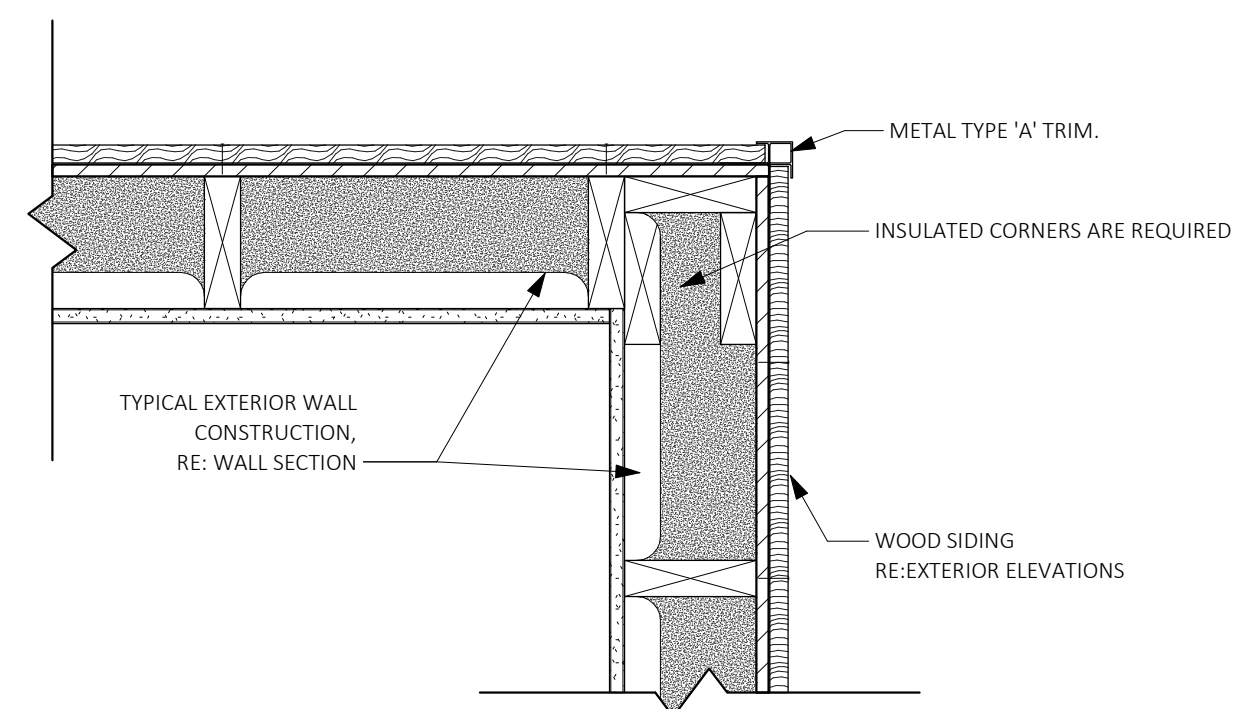

**6 EXT O/S CORNER DETAIL @ WD SIDING**  
 1 1/2" = 1'-0"

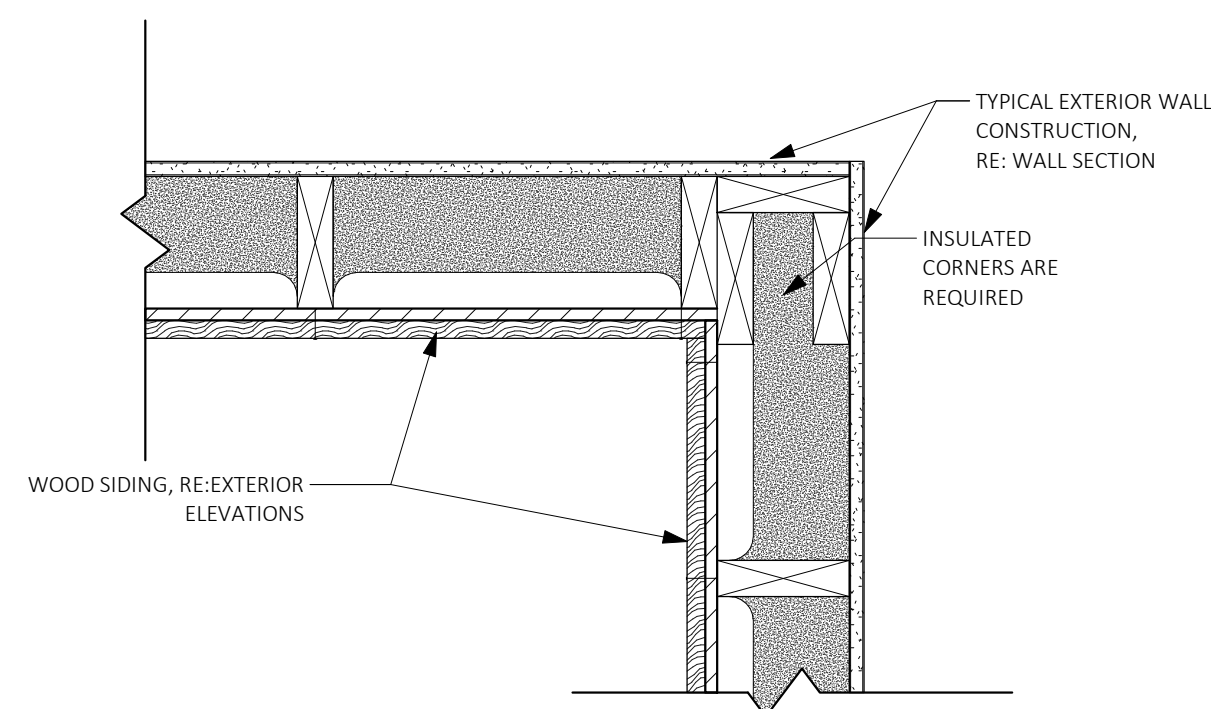

**7 EXT I/S CORNER @ WOOD SIDING**  
 1 1/2" = 1'-0"



FRONTIER PAVER PATIO LAYUP

**8 PATIO LAYUP - FRONTIER**  
 3/4" = 1'-0"

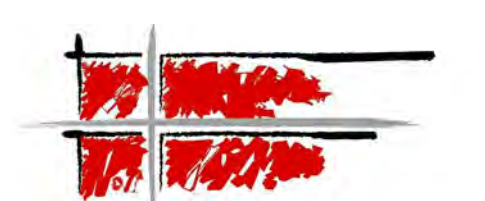

**COLORADO:**  
10125 RANCHO MONTECITO  
DR. PARKER, COLORADO 80138  
P 303.840.0020

**MONTANA:**  
P.O. BOX 161488  
11 LONE PEAK DR., UNIT 206  
BIG SKY, MONTANA 59716  
P 406.995.7572

**UTAH:**  
1960 SIDEWINDER DR., #101  
PARK CITY, UTAH 84060  
P 435.604.0891

www.centresky.com

TELLURIDE #6  
TELLURIDE, CO 81435

NOT FOR  
CONSTRUCTION



Issued For \_\_\_\_\_ Date \_\_\_\_\_  
• 100% S.D. 01/14/2021  
• Pricing # \_\_\_\_\_  
• ARC Sketch Review 01/14/2021  
• 100% D.D. \_\_\_\_\_  
• ARC Final Review \_\_\_\_\_  
• 100% C.D. \_\_\_\_\_  
• REV. # \_\_\_\_\_

Drawn By S. D'AGOSTINO  
Date 01/14/2021  
Project # 2021.00  
Phase SD  
Sheet

**A6-1.2**  
WINDOW  
SCHEDULE

WINDOW SCHEDULE														REMARKS			
WINDOW #	SIZE		ELEVATION	OPERATION	MFR	PROFILE	FINISH		FRAME DETAIL # /AG-1.3			TRIM DETAILS			HARDWARE		GLASS TYPE
	WIDTH	HEIGHT					INTERIOR	EXTERIOR	HEAD	JAMB	SILL	INTERIOR	EXTERIOR		SET	FINISH	
002-1	3'-3"	2'-0"		AWNING			CLEAR PINE	BLACK									IG Low E II with Argon
002-2	5'-3"	2'-0"		AWNING			CLEAR PINE	BLACK									IG Low E II with Argon
002-3	5'-3"	2'-0"		AWNING			CLEAR PINE	BLACK									IG Low E II with Argon
002-4	3'-3"	6'-0"		CASEMENT			CLEAR PINE	BLACK									IG Low E II with Argon
002-5	5'-3"	6'-0"		FIXED			CLEAR PINE	BLACK									IG Low E II with Argon
002-6	5'-3"	6'-0"		FIXED			CLEAR PINE	BLACK									IG Low E II with Argon
002-7	6'-0"	10'-0"		FIXED			CLEAR PINE	BLACK									IG Low E II with Argon
002-8	6'-0"	10'-0"		FIXED			CLEAR PINE	BLACK									IG Low E II with Argon
002-9	6'-0"	10'-0"		FIXED			CLEAR PINE	BLACK									IG Low E II with Argon
005-1	5'-0"	5'-6"		FIXED													IG Low E II with Argon
005-2	3'-0"	5'-6"		CASEMENT													IG Low E II with Argon
005-3	4'-0"	5'-6"		FIXED													IG Low E II with Argon
101-1	3'-0"	9'-0"		FIXED			CLEAR PINE	BLACK									IG Low E II with Argon
101-2	3'-0"	9'-0"		FIXED			CLEAR PINE	BLACK									IG Low E II with Argon
101-3	3'-0"	9'-0"		FIXED			CLEAR PINE	BLACK									IG Low E II with Argon
103-1	3'-0"	7'-0"		CASEMENT													IG Low E II with Argon
103-2	5'-3"	2'-0"		AWNING			CLEAR PINE	BLACK									IG Low E II with Argon
103-3	3'-0"	7'-0"		CASEMENT													IG Low E II with Argon
103-4	5'-3"	7'-0"		FIXED			CLEAR PINE	BLACK									IG Low E II with Argon
103-5	3'-3"	2'-0"		FIXED			CLEAR PINE	BLACK									IG Low E II with Argon
106-1	5'-3"	2'-0"		AWNING			CLEAR PINE	BLACK									IG Low E II with Argon
106-2	5'-3"	7'-0"		FIXED			CLEAR PINE	BLACK									IG Low E II with Argon
106-3	6'-0"	9'-0"		FIXED			CLEAR PINE	BLACK									IG Low E II with Argon
106-4	6'-0"	9'-0"		FIXED			CLEAR PINE	BLACK									IG Low E II with Argon
106-5	6'-0"	9'-0"		FIXED			CLEAR PINE	BLACK									IG Low E II with Argon
107-1	5'-0"	8'-0"		FIXED			CLEAR PINE	BLACK									IG Low E II with Argon
108-1	4'-0"	2'-0"		AWNING			CLEAR PINE	BLACK									IG Low E II with Argon
108-2	4'-0"	2'-0"		AWNING			CLEAR PINE	BLACK									IG Low E II with Argon
108-3	4'-0"	2'-0"		AWNING			CLEAR PINE	BLACK									IG Low E II with Argon
108-4	4'-0"	6'-0"		FIXED			CLEAR PINE	BLACK									IG Low E II with Argon
108-5	4'-0"	6'-0"		FIXED			CLEAR PINE	BLACK									IG Low E II with Argon
108-6	4'-0"	6'-0"		FIXED			CLEAR PINE	BLACK									IG Low E II with Argon
109-1	2'-6"	2'-0"		FIXED			CLEAR PINE	BLACK									IG Low E II with Argon
110-1	3'-0"	2'-0"		AWNING			CLEAR PINE	BLACK									IG Low E II with Argon
110-2	4'-0"	2'-0"		FIXED			CLEAR PINE	BLACK									IG Low E II with Argon
110-3	3'-0"	2'-0"		AWNING			CLEAR PINE	BLACK									IG Low E II with Argon
110-4	3'-0"	6'-0"		CASEMENT			CLEAR PINE	BLACK									IG Low E II with Argon
110-5	4'-0"	6'-0"		FIXED			CLEAR PINE	BLACK									IG Low E II with Argon
110-6	3'-0"	6'-0"		CASEMENT			CLEAR PINE	BLACK									IG Low E II with Argon
202-1	5'-3"	2'-0"		AWNING			CLEAR PINE	BLACK									IG Low E II with Argon
202-2	5'-3"	2'-0"		AWNING			CLEAR PINE	BLACK									IG Low E II with Argon
202-3	5'-3"	2'-0"		AWNING			CLEAR PINE	BLACK									IG Low E II with Argon
202-4	5'-3"	2'-0"		AWNING			CLEAR PINE	BLACK									IG Low E II with Argon
202-5	5'-3"	8'-0"		FIXED			CLEAR PINE	BLACK									IG Low E II with Argon
202-6	5'-3"	8'-0"		FIXED			CLEAR PINE	BLACK									IG Low E II with Argon
202-7	5'-3"	8'-0"		FIXED			CLEAR PINE	BLACK									IG Low E II with Argon
202-8	5'-3"	8'-0"		FIXED			CLEAR PINE	BLACK									IG Low E II with Argon
202-9	5'-3"	4'-4 1/4"		FIXED TRAP			CLEAR PINE	BLACK									IG Low E II with Argon
202-10	5'-3"	3'-10 3/4"		FIXED TRAP			CLEAR PINE	BLACK									IG Low E II with Argon
202-11	5'-3"	3'-5 1/2"		FIXED TRAP			CLEAR PINE	BLACK									IG Low E II with Argon
202-12	5'-3"	3'-0 1/2"		FIXED TRAP			CLEAR PINE	BLACK									IG Low E II with Argon
202-13	4'-8"	5'-6"		FIXED			CLEAR PINE	BLACK									IG Low E II with Argon
202-14	4'-8"	5'-6"		FIXED			CLEAR PINE	BLACK									IG Low E II with Argon
202-15	5'-6"	2'-0"		FIXED TRAP			CLEAR PINE	BLACK									IG Low E II with Argon
202-16	5'-6"	2'-5 1/2"		FIXED TRAP			CLEAR PINE	BLACK									IG Low E II with Argon
202-17	5'-6"	2'-11"		FIXED TRAP			CLEAR PINE	BLACK									IG Low E II with Argon
202-18	5'-6"	3'-4 1/2"		FIXED TRAP			CLEAR PINE	BLACK									IG Low E II with Argon
203-1	3'-6"	10'-0"		FIXED			CLEAR PINE	BLACK									IG Low E II with Argon
203-2	6'-0"	10'-0"		FIXED			CLEAR PINE	BLACK									IG Low E II with Argon
203-3	6'-0"	10'-0"		FIXED			CLEAR PINE	BLACK									IG Low E II with Argon
203-4	6'-0"	10'-0"		FIXED			CLEAR PINE	BLACK									IG Low E II with Argon
203-5	6'-0"	2'-0"		FIXED TRAP			CLEAR PINE	BLACK									IG Low E II with Argon
203-6	6'-0"	1'-5 3/4"		FIXED TRAP			CLEAR PINE	BLACK									IG Low E II with Argon
203-7	6'-0"	0'-6"		FIXED TRAP			CLEAR PINE	BLACK									IG Low E II with Argon
204-1	5'-0"	9'-0"		FIXED			CLEAR PINE	BLACK									IG Low E II with Argon
204-2	4'-0"	2'-0"		AWNING			CLEAR PINE	BLACK									IG Low E II with Argon
204-3	4'-0"	2'-0"		AWNING			CLEAR PINE	BLACK									IG Low E II with Argon
204-4	4'-0"	2'-0"		AWNING			CLEAR PINE	BLACK									IG Low E II with Argon
204-5	4'-0"	7'-0"		FIXED			CLEAR PINE	BLACK									IG Low E II with Argon
204-6	4'-0"	7'-0"		FIXED			CLEAR PINE	BLACK									IG Low E II with Argon
204-7	4'-0"	7'-0"		FIXED			CLEAR PINE	BLACK									IG Low E II with Argon
204-8	3'-6"	2'-0"		AWNING			CLEAR PINE	BLACK									IG Low E II with Argon
204-9	3'-6"	7'-0"		FIXED			CLEAR PINE	BLACK									IG Low E II with Argon
205-1	8'-0"	2'-0"		AWNING			CLEAR PINE	BLACK									IG Low E II with Argon
205-2	8'-0"	7'-0"		FIXED			CLEAR PINE	BLACK									IG Low E II with Argon
206-1	8'-0"	6'-0"		FIXED			CLEAR PINE	BLACK									IG Low E II with Argon
208-1	6'-0"	6'-0"		FIXED			CLEAR PINE	BLACK									IG Low E II with Argon
208-2	6'-0"	6'-0"		FIXED			CLEAR PINE	BLACK									IG Low E II with Argon
208-3	6'-0"	6'-0"		FIXED			CLEAR PINE	BLACK									IG Low E II with Argon
210-1	1'-6"	9'-0"		FIXED			CLEAR PINE	BLACK									IG Low E II with Argon
210-2	1'-6"	9'-0"		FIXED			CLEAR PINE	BLACK									IG Low E II with Argon
212-1	5'-3"	8'-0"		FIXED			CLEAR PINE	BLACK									IG Low E II with Argon
213-1	8'-0"	2'-6"		FIXED			CLEAR PINE	BLACK									IG Low E II with Argon
213-2	8'-0"	2'-6"		FIXED			CLEAR PINE	BLACK									IG Low E II with Argon

Grand total: 84

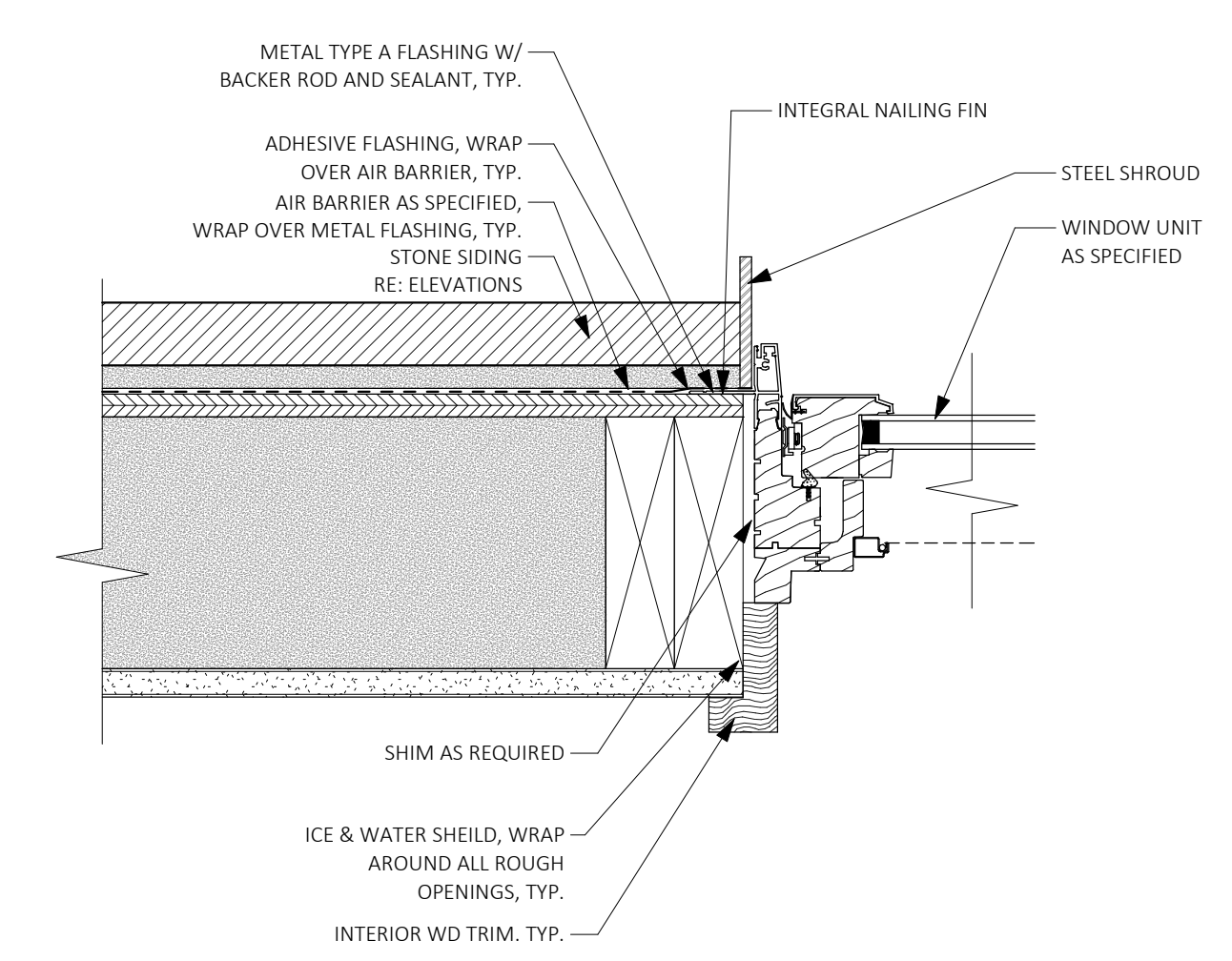

1 TYP WINDOW JAMB @ STONE SIDING  
3" = 1'-0"

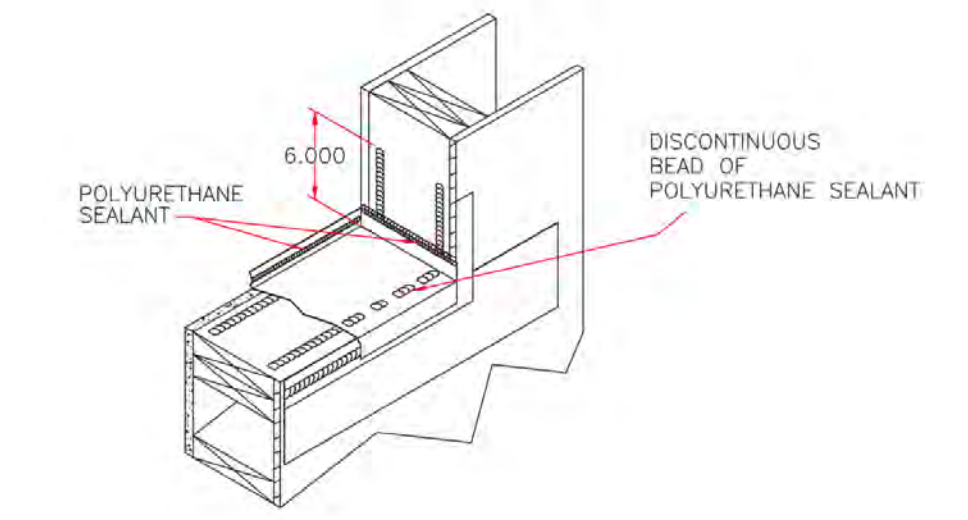

6 TYP WINDOW SEALANT @ B.O. WINDOW  
1" = 1'-0"

- WINDOW GENERAL NOTES**
- REFER TO EXTERIOR ELEVATIONS AND WINDOW SCHEDULE FOR DIRECTION OF OPERABLE WINDOW SWING.
  - REFER TO PLANS & EXTERIOR ELEVATIONS FOR EGRESS WINDOW LOCATIONS.
  - WINDOW MANUFACTURER TO VERIFY THAT ALL EGRESS WINDOWS MEET EGRESS REQUIREMENTS IN ACCORDANCE TP 2013 IBC AND ADVISE ARCHITECT OF ANY CONFLICTS.
  - REFERENCE WINDOW SCHEDULE FOR ALL MILLED UNITS.
  - REFERENCE WINDOW ELEVATIONS FOR ALL TRAPAZOID UNITS.
  - WINDOW SUPPLIER TO PROVIDE FINAL SHOP DRAWINGS AND LIST TO ARCHITECT FOR REVIEW PRIOR TO PLACING ORDER.
  - ALL WINDOW ELEVATIONS ARE EXTERIOR ELEVATIONS.
  - GENERAL CONTRACTOR TO INSPECT ALL GLASS AND FRAMES FOR DEFECTS PRIOR TO INSTALL.
  - REFER TO FINISH SCHEDULE FOR SPECIFIC STAIN & PAINT FINISHES.



**COLORADO:**  
10125 RANCHO MONTECITO  
DR. PARKER, COLORADO 80138  
P 303.840.0020

**MONTANA:**  
P.O. BOX 161488  
11 LONE PEAK DR., UNIT 206  
BIG SKY, MONTANA 59716  
P 406.995.7572

**UTAH:**  
1960 SIDEWINDER DR., #101  
PARK CITY, UTAH 84060  
P 435.604.0891

www.centresky.com



TELLURIDE #6  
TELLURIDE, CO 81435

NOT FOR  
CONSTRUCTION



Issued For \_\_\_\_\_ Date \_\_\_\_\_  
• 100% S.D. 01/14/2021  
• Pricing # \_\_\_\_\_  
• ARC Sketch Review 01/14/2021  
• 100% D.D. \_\_\_\_\_  
• ARC Final Review \_\_\_\_\_  
• 100% C.D. \_\_\_\_\_  
• REV. # \_\_\_\_\_

Drawn By S. D'AGOSTINO  
Date 01/14/2021  
Project # 2021.00  
Phase SD  
Sheet

**A6-2.1**  
DOOR ELEVATIONS  
& SCHEDULE

DOOR #	DOOR SCHEDULE													REMARKS					
	SIZE			ELEVATION TYPE	SWING	MATERIAL	MFR	FINISH	INT/EXT	FRAME DETAIL #/A6-2.2			TRIM TYPE		HARDWARE				
	W	H	T							HEA	DER	JAMB	SILL		EXT.	INT.	FUNCTION	STYLE	FINISH
001A	3'-0"	8'-0"	0'-1 3/4"																
004A	2'-6"	8'-0"	0'-1 3/8"																
005B	3'-0"	8'-0"	0'-1 3/8"																
007A	3'-0"	8'-0"	0'-1 3/8"																
007B	2'-6"	8'-0"	0'-1 3/8"																
007C	2'-6"	8'-0"	0'-0 3/8"		RE: PLAN					INT									
008A	3'-0"	8'-0"	0'-1 3/8"		BARN					INT									
008B	2'-6"	8'-0"	0'-1 3/8"		RE: PLAN					INT									
008C	2'-6"	8'-0"	0'-1 3/8"		RE: PLAN					INT									
008D	2'-6"	8'-0"	0'-0 3/8"																
005A	3'-0"	8'-0"	0'-1 3/4"																
101A	3'-0"	9'-0"	0'-2 1/4"		RE: PLAN					EXT									
103A	3'-0"	8'-0"	0'-1 3/4"		RE: PLAN					INT									
103B	3'-6"	8'-0"	0'-1 3/8"		POCKET					INT									
104A	2'-6"	8'-0"	0'-1 3/8"							INT									
104B	2'-6"	7'-0"	0'-0 3/8"		RE: PLAN					INT									
104C	2'-6"	8'-0"	0'-1 3/8"		POCKET					INT									
105A	5'-4"	8'-0"	0'-2"		DOUBLE					INT									
107A	3'-0"	8'-0"	0'-2 1/4"		RE: PLAN					EXT									
108A	3'-0"	8'-0"	0'-1 3/4"		RE: PLAN					INT									
108B	4'-0"	8'-0"	0'-2"		DOUBLE					INT									
109A	2'-6"	8'-0"	0'-1 3/8"		POCKET					INT									
109B	2'-6"	7'-0"	0'-0 3/8"		RE: PLAN					INT									
109C	2'-6"	8'-0"	0'-1 3/8"		POCKET					INT									
110A	3'-0"	8'-0"	0'-1 3/4"		RE: PLAN					INT									
111A	3'-0"	8'-0"	0'-1 3/4"		RE: PLAN					INT									
111B	2'-6"	7'-0"	0'-0 3/8"		RE: PLAN					INT									
111C	2'-6"	8'-0"	0'-1 3/8"		POCKET					INT									
112A	3'-0"	8'-0"	0'-1 3/4"		RE: PLAN					INT									
113A	5'-4"	8'-0"	0'-2"		DOUBLE					INT									
114A	2'-6"	8'-0"	0'-1 3/8"		POCKET					INT									
115A	3'-0"	8'-0"	0'-1 3/4"		RE: PLAN					INT									
201	3'-0"	8'-0"	0'-2 1/4"		RE: PLAN					EXT									
202A	4'-3 5/8"	9'-10 7/8"	0'-2 1/4"		BI-FOLD					EXT									
202B	4'-3 5/8"	9'-10 7/8"	0'-2 1/4"		BI-FOLD					EXT									
204A	3'-0"	8'-0"	0'-1 3/8"		POCKET					INT									
204B	3'-0"	9'-0"	0'-2 1/4"		RE: PLAN					EXT									
205A	3'-0"	8'-0"	0'-1 3/8"		POCKET					INT									
205B	2'-6"	8'-0"	0'-1 3/8"		POCKET					INT									
205C	2'-6"	8'-0"	0'-0 3/8"		RE: PLAN					INT									
210A	4'-6"	9'-0"	0'-2 1/4"		PIVOT					EXT									
211	2'-6"	8'-0"	0'-1 3/4"		POCKET					INT									
213A	3'-0"	8'-6"	0'-1 3/4"		RE: PLAN					EXT									
213B	18'-0"	8'-6"	0'-1 3/4"		GARAGE					EXT									
213C	3'-0"	8'-0"	0'-1 3/4"		RE: PLAN					INT									

Grand total: 45

- DOOR SCHEDULE NOTES:**
- ALL BARN DOOR SLABS TO BE 2" WIDER THAN FINISHED OPENING
  - PROVIDE TRACKS AT BOTTOM OF ALL BARN DOORS
  - ALL W/D DOORS SHALL BE ENGINEERED LAMINATED DOORS U.N.O. GC TO COORDINATE JAMB WIDTHS ACCORDING TO VARYING WALL WIDTH, SEE FLOOR PLAN FOR WALL TYPES AND WIDTHS
  - GC TO COORDINATE JAMB WIDTHS WITH INTERIOR SHEAR WALL LOCATIONS (IF APPLICABLE) - SEE STR FOR SHEAR WALL LOCATIONS
  - VERIFY FINISHES WITH ARCH/OWNER AND ID
  - VERIFY PRIVACY LOCKS ON BEDROOMS AND BATHROOMS W/ OWNER
  - VERIFY ALL DOOR SWINGS WITH OWNER/ARCH PRIOR TO PRODUCTION
  - FOR ALL DOORS AT STRIKE PLATE LOCATION, PAINT EXPOSED JAMB AND ANY EXPOSED FRAMING BEHIND STRIKE PLATE BLACK, TYP. RECESSED AREAS ON EXTERIOR DOORS TO HAVE BEVELLED EDGES SLOT ON HEAD OF SCREWS TO ALIGN VERTICALLY ON DOOR HARDWARE
  - ALL EXTERIOR DOORS TO RECEIVE APPROPRIATE WEATHER STRIPPING
  - NEOPRENE DOOR SHIMS SHALL BE USED SIMILAR TO THE PRODUCT BY 'ENDURA'
  - DOOR CORNER SEALS TO BE INSTALLED ON ALL EXTERIOR HINGED DOORS, COLOR TO MATCH WEATHERSTRIPPING
  - ALL GARAGE DOORS TO HAVE AUTOMATIC CLOSE WEDGES ON ALL HINGED EXTERIOR DOORS ON STRIKE SIDE
  - ALL EXTERIOR HINGED OR PIVOT DOORS TO RECEIVE CORNER SEALS

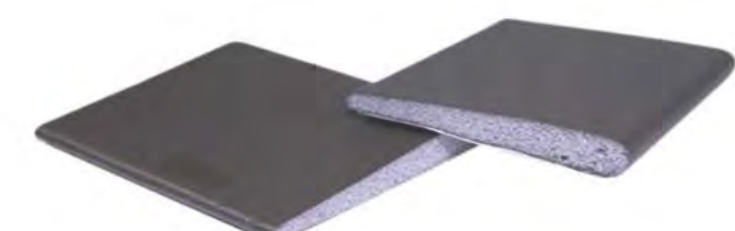

M-D BUILDING PRODUCTS FOAM VINYL CORNER WEATHERSEALS FOR DOORS 1-3/4" X 0.131" COLOR ALWAYS BLACK

1 TYP. CORNER WEATHERSEALS HINGED DOORS 1 1/2" = 1'-0"

## John A. Miller

---

**From:** Rich Ganley <richganman1@gmail.com>  
**Sent:** Monday, January 25, 2021 5:30 PM  
**To:** John A. Miller  
**Subject:** Re: Unit 6 Cortina

Hi John,

After looking at the proposed variance request for lot 165 we are opposed to this request.

As the President of Lodges on Sundance, the board and homeowners of our neighborhood do NOT support this applicant's request for the variance.

This variance would be way out of scale for our neighborhood, it is too high and the applicant should be held to the original standards they knew and had when purchasing the lot. We also feel that a variance of this type would negatively affect our quality and values at LOS and Mountain Village.

Please deny this variance request.

Thanks

Rich Ganley  
Positive Impact Executive  
C- 602-432-8178

On Mon, Jan 25, 2021 at 5:11 PM John A. Miller <[JohnMiller@mtnvillage.org](mailto:JohnMiller@mtnvillage.org)> wrote:

Afternoon Rich – They are requesting a 20'-4" height variance. Staff will have difficulty supporting such a large variance request. I encourage you to submit any letters of support or opposition tomorrow if possible so I can provide them in the packet to DRB next week.

John A Miller III, CFM

Senior Planner

Planning & Development Services

Town of Mountain Village

455 Mountain Village Blvd, Suite A

Mountain Village, CO 81435

O :: 970.369.8203



For information about The Town of Mountain Village's response to COVID-19 (Coronavirus), please visit [townofmountainvillage.com/coronavirus/](https://townofmountainvillage.com/coronavirus/)

---

**From:** Rich Ganley <[richganman1@gmail.com](mailto:richganman1@gmail.com)>  
**Sent:** Monday, January 25, 2021 4:57 PM  
**To:** cd <[cd@mtnvillage.org](mailto:cd@mtnvillage.org)>  
**Subject:** Unit 6 Cortina

Hi, This is Rich Ganley. We revived notice about the planned building at lot 165 Unit 6 Cortina.

I am the President of Lodges on Sundance and we are concerned about this project.

A quick question:.

1. How much do they want to vary from the 35 feet height ?

Thanks so much

Rich Ganley

Positive Impact Executive

C- 602-432-8178



AGENDA ITEM 5  
**PLANNING & DEVELOPMENT SERVICE**  
**PLANNING DIVISION**  
455 Mountain Village Blvd.  
Mountain Village, CO 81435  
(970) 728-1392

---

**TO:** Mountain Village Design Review Board  
**FROM:** Amy Ward, Planner  
**FOR:** Design Review Board Public Hearing; February 4, 2021  
**DATE:** January 22, 2021  
**RE:** Staff Memo – Initial Architecture and Site Review (IASR) 729R-5, 91 Pennington Place

---

### APPLICATION OVERVIEW: New Single-Family Home on Lot 729R-5

#### **PROJECT GEOGRAPHY**

**Legal Description:** LOT 729R-5, MOUNTAIN VILLAGE, ACCORDING TO TO THE PLAT OF LOTS 726R-1, 729R-1, 729R-2, 729R-3, 729R-4, 729R-5, 729R-6 & 729R-7 REPLAT, REZONE AND DENSITY TRANSFER, A REPLAT OF LOTS 726R, 729R AND TRACT 727R, MOUNTAIN VILLAGE, COLORADO, RECORDED JANUARY 23, 2001 IN PLAT BOOK 1 AT PAGE 2850, COUNTY OF SAN MIGUEL, STATE OF COLORADO.

**Address:** 91 Pennington Place  
**Applicant/Agent:** Peter Lundeen, FUSE Architecture & Interiors  
**Owner:** John & Lisa Baccich  
**Zoning:** Single-Family  
**Existing Use:** Vacant Lot  
**Proposed Use:** Single-Family  
**Lot Size:** .769 acres  
**Adjacent Land Uses:**

- **North:** Single Family
- **South:** Single-Family
- **East:** Single-Family
- **West:** Open Space

#### **ATTACHMENTS**

Exhibit A: Architectural Plan Set  
Exhibit B: Staff/Public Comment

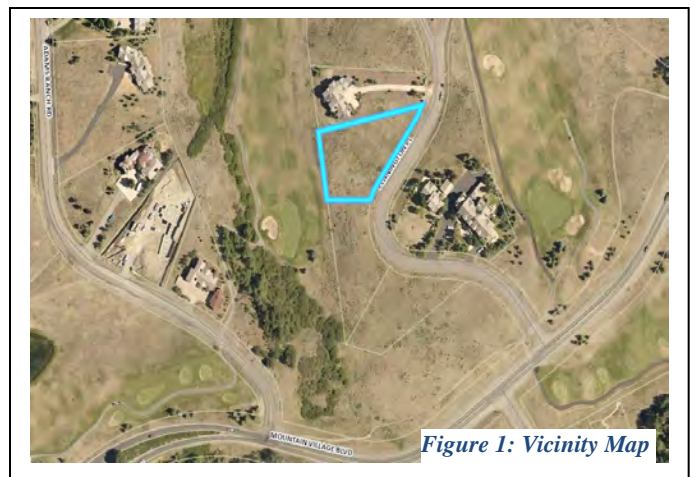

*Figure 1: Vicinity Map*

**Case Summary:** Peter Lundeen of FUSE Architecture & Interior, Applicant for Lot 729R-5 is requesting Design Review Board (DRB) approval of an Initial Architectural and Site

Review (IASR) Application for a new single-family home on Lot 729R-5, 91 Pennington Place. The Lot is approximately .769 acres and is zoned Single-Family. The overall square footage of the home is approximately 4,543 gross square feet and provides 2 interior parking spaces within the proposed garage and 2 exterior parking spaces.

**Applicable CDC Requirement Analysis:** The applicable requirements cited may not be exhaustive or all-inclusive. The applicant is required to follow all requirements even if an applicable section of the CDC is not cited. ***Please note that Staff comments will be indicated by italicized Text.***

*Table 1*

<u>CDC Provision</u>	<u>Requirement</u>	<u>Proposed</u>
<b>Maximum Building Height</b>	35' (shed) / 40' (gable) Maximum	34'3"
<b>Maximum Avg. Building Height</b>	30' (shed) / 35' (gable) Maximum	24.43'
<b>Maximum Lot Coverage</b>	40% Maximum (s.f.)	15.9%
<b>General Easement Setbacks*</b>	No encroachment	Parking
<b>Roof Pitch</b>		
Primary		2:12
Secondary		3:12
<b>Exterior Material</b>		
Stone	35% minimum	36.15%
Windows/Doors	40% maximum	21.58%
<b>Parking</b>	2 enclosed / 2 exterior	2/2*

**Design Review Board Specific Approvals:**

**1. Partial Metal Fascia**

**Chapter 17.3: ZONING AND LAND USE REGULATIONS**

**17.3.12: Building Height Limits**

Sections 17.3.11 and 17.3.12 of the CDC provide the methods for measuring Building Height and Average Building Height, along with providing the height allowances for specific types of buildings based on their architectural form. The proposed design incorporates Shed roof forms which are limited to 35 feet. The maximum average height must be at or below 30 feet for shed roof forms. The average height is an average of measurements from a point halfway between the roof ridge and eave. The points are generally every 20 feet around the roof. The maximum height is measured from the highest point on a roof directly down to the existing grade or finished grade, whichever is more restrictive.

*Staff: the applicant meets all height requirements.*

**17.3.14: General Easement Setbacks**

Lot 729R-5 is burdened by a sixteen (16) foot General Easement (GE) which surrounds its perimeter. The CDC provides that the GE and other setbacks be maintained in a natural, undisturbed state to provide buffering to surrounding land uses. The CDC does provide for some development activity within the GE and setbacks such as Ski Access, Utilities, Address Monuments, and Fire Mitigation. All encroachments not listed above will require encroachment agreements between the property owner and the Town.

*Staff: The proposal includes several GE encroachments that fall into the above category of permitted GE development activity including the following:*

- *Driveway and Address Monument: the address monument is located within the GE and will require a GE encroachment agreement.*
- *Utilities: Gas, Water, Cable, Electric and Phone are already located within Pennington Place and will require crossing the GE to the home. Within the Pennington Place right of way there is also sewer connections, but due to topography, the applicant is proposing to access the sewer main to the West of the property on OS-28. This connection may require that the applicant work with Telluride Ski and Golf in order to obtain access if there is not currently legal access for this connection. In addition, the water connection indicated is in the GE in front of the adjoining lot.*

*Staff: The proposal also includes a GE encroachment that does not fall into the aforementioned category and will require DRB approval. A portion of one of their exterior parking spaces is in the SE General Easement. The CDC allows for parking to be located within the GE in specific cases where the DRB waives the General Easement Setback and allows for prohibited activities.*

*The applicant has indicated that the parking area within the GE has been designed as such in order to limit grading and disturbances in order to preserve natural features on the lot such as wetlands and steep slopes.*

## **Chapter 17.5: DESIGN REGULATIONS**

### **17.5.4: Town Design Theme**

The Town of Mountain Village has established design themes aimed at creating a strong image and sense of place for the community. Due to the fragile high alpine environment, architecture and landscaping shall be respectful and responsive to the tradition of alpine design – reflecting elements of alpine regions while blending influences that visually tie the town to mountain buildings. The town recognizes that architecture will continue to evolve and create a regionally unique mountain vernacular, but these evolutions must continue to embrace nature and traditional style in a way that respects the design context of the neighborhoods surrounding the site.

*Staff: The applicant has designed the home in a way that utilizes the topography of the site, allowing the home to step down the lot gently. The design of the home is reminiscent of a mining structure and appears to fit well with the overall regional influences and vernacular of the Mountain Village. Although the home is meeting the material requirements, there are portions of the home that feel less grounded than others due to the lack of stone along finished grade, particularly the southwest and northeast elevations. Staff has concerns related to material durability as it relates to weather and snow.*

*The applicant has designed the home with multiple roof planes breaking up each elevation. Additionally, the proposed material palette for the home utilizes a stone, steel and stained wood mix similar to what we have seen in many other recent applications. The horizontal stone arrangements and square metal panels appear to compliment the vertical wood panelling in a way that not only contrasts but provides grounding. Overall it appears that the design is visually appealing and would fit within the existing Mountain Village Design Theme. It may be beneficial to slightly increase the stone in certain areas as noted above.*



### **17.5.5: Building Siting Design**

The CDC requires that any proposed development blend into the existing landforms and vegetation.

*Staff: The proposed home steps down the site along a slight ridgeline that runs from the southeast to the northwest corner of the lot. The northeast corner of the property has two wetland areas. Allowing for a buffer between the home and the wetlands pushes the home site onto the SW portion of the lot. The SE corner of the garage is close to the 16' GE, and a portion of one of the exterior parking spaces encroaches into the GE slightly (28%). One solution to this would be to push the whole home to the NW to remove this encroachment, however in doing so the NW elevation of the house would become quite tall (possibly over the height limits).*

### **17.5.6: Building Design**

*Staff: The CDC requires that building form and exterior wall forms portray a mass that is thick and strong with a heavy grounded foundation. The building form follows the natural slope of the lot. The low garage form steps up to the home's highest point and the rest of the structure gradually steps down from there. Overall, the home looks fairly balanced and grounded, but the addition of some stone where the grade meets any wood siding would help to cement this groundedness as well as provide some protection from potential snow damage as mentioned previously.*

*Another element to the design that varies from the rest of the home and therefore stands out is the 3 story glass atrium on the northeast elevation. The applicant is still well within the guidelines for allowable fenestration, but staff wanted to point out this feature for DRB to discuss if necessary.*

*Based on the plans provided, the applicant is meeting all materials requirements for Stone and Glazing. Proposed materials are a general concept at this point, and will need to be finalized before final review. Stain colors, rail materials, decking and retaining wall materials also need to be called out for final. Overall, the contrast of the wood, steel and stone appears to complement the design.*

*The applicant has included specifications for Pella windows and doors, but it is not clear what the intended profile or finish is. Additionally, the recess depth of all doors and windows in stone areas needs to be called out. The proposed roofing material is a traditional charcoal grey standing seam product. The fascia of the home will be half metal and half wood stained to match the siding. According to the CDC, the use of metal fascia is a specific approval and the DRB will need to grant this approval as part of this application. The CDC allows for black and grey standing seam roofing materials and this appears to meet that requirement.*

### **17.5.7: Grading and Drainage Design**

*Staff: The applicant has attempted to reduce cut and fill on the site by placing the home close to Pennington Place in order to utilize natural grade as much as possible for the autocourt. There will be some retainage necessary on the SW side of the drive, which is the side furthest from the wetlands, reducing its potential impact. For most of the lot they have left the natural grade of the site intact.*

### **17.5.8: Parking Regulations**

*Staff: The CDC requires all single-family developments to provide two interior and two exterior parking spaces. The applicant has shown a total of 2 interior spaces and 2 exterior spaces that meet the required sizes of 9' x 18. The parking space on the SE side of the*

garage is partially in the 16' GE. Although they have indicated that this space is a 28% encroachment on the GE it is actually a bit less as their drawing shows a 10' x 20' parking space, which is larger than required. Members of DRB will have to decide whether the restrictions of the site warrant this encroachment.

#### **17.5.9: Landscaping Regulations**

The applicant has not provided a landscaping plan with sufficient detail to include irrigation notes, revegetation notes, and other general requirements. Prior to final, the applicant shall submit a landscaping plan and a fire mitigation plan that meets the Forestry provisions of the CDC.

#### **17.5.11: Utilities**

Staff: Utilities are currently located within the Pennington Place roadway and OS 28. They will only require connections to the home. The applicant shall work with the Public Works Director and TSG (for sewer) before the final review to determine the specific locations of the connections for the home. The plan set shows the proposed connections and the locations of the proposed utilities based on field research.

#### **17.5.12: Lighting Regulations**

Staff: The applicant has provided an exterior lighting plan, but has not included any fixture specifications or a photometric study. The applicant shall provide such details prior to final.

#### **17.5.13: Sign Regulations**

Staff: The address marker is located in the GE on the north side of the driveway. It uses materials that match the home, and the indicated heights and lettering meet CDC guidelines. Lighting is not indicated, but is required per the CDC and must be downlit and compliant. Numbers will be reflective and presented on a grey metal background.

### **Chapter 17.6: SUPPLEMENTARY REGULATIONS**

#### **17.6.1: Environmental Regulations**

Staff: Fire Mitigation and Forestry Management: A more detailed plan, indicating zones needs to be provide for FAR. As there are currently no trees on the lot, this could be included with the landscaping plan. Generally, lots in this area have been able to waive some requirements of the provisions in order to provide landscaping, recognizing that the area is at lower risk than other higher fuel areas in the Mountain Village.

Steep Slopes: The building site has a steep slope on the south end of the lot. The retainage for the autocourt overlaps this area slightly. There is another small area of steep slope just south of the wetlands along the road. In order to mitigate slope impacts the applicant has designed the project to retain portions of this steep slope area.

Wetlands: There are two wetlands on the northeast corner of the property. The wetlands need to be re-delineated, of which the applicant is aware. This re-delineation can't happen until after snowmelt in the spring. There is the potential that some redesign might need to occur if there is a large change in the wetland delineation. Additionally, the utilities are located close to one of these wetlands and it is possible that horizontal boring might be required to access these utilities per the delineation.

#### **17.6.6: Roads and Driveway Standards**

Staff: The driveway as shown meets the CDC standards with 12 feet width and 2-foot shoulders on each side. The maximum grade of the driveway appears to be approximately 12% and overall, it ranges from 5-12% grade. Because of the 12% grade, the home will be required to be sprinkled. Although no snowmelt is indicated on the planset, the

*relatively steep driveway leading to a tight parking scenario could be cause for considering a snowmelt system.*

*The retaining walls on the south side of the autocourt do not meet the requirements of the CDC as shown. There are both a 6' and 5'5" wall shown, whereas the maximum height allowable by code is 5.'*

#### **17.6.8: Solid Fuel Burning Device Regulations**

*Staff: The applicant has indicated that the proposed home does include fireplaces and that they are to run on gas.*

### **Chapter 17.7: BUILDING REGULATIONS**

#### **17.7.19: Construction Mitigation**

*Staff: The applicant has not submitted a construction mitigation plan, some erosion control is indicated on his drainage plan but a more formal construction mitigation plan needs to be developed prior to final. There are space/road constraints in this neighborhood, the architect should begin to work with a contractor to develop the mitigation plan showing appropriate parking, staging of materials, a potential crane, dumpsters, etc.*

*Additionally, the wetlands on the NE corner of the property warrant a comprehensive protection strategy, drainage plans indicate silt fence and sediment control logs, however it will be important to make sure that the proposed controls offer enough protection. The addition of more sediment control logs is advised.*

**Staff Recommendation:** Staff recommends the DRB approve the Initial Architectural and Site Review for Lot 729R-5, 91 Pennington Place based on the findings and CDC requirements listed in the staff memo of record.

**Staff Note:** *It should be noted that reasons for approval or rejection should be stated in the findings of fact and motion.*

#### **Proposed Motion:**

If the DRB deems this application to be appropriate for approval, Staff requests said approval condition the items listed below in the suggested motion.

I move to approve the Initial Architectural and Site Review for a new single-family home located at Lot 729R-5, based on the evidence provided within the Staff Report of record dated January 22, 2021, with the following Design Variations and Specific Approvals:

- 1) Metal Fascia;
- 2) Parking in the General Easement
- 3) Driveway Grade over 8%

And, with the following conditions:

- 1) Prior to the submittal for a Final Architectural Review, the applicant shall provide a landscape plan and a fire mitigation plan.

- 2) Prior to the submittal for a Final Architectural Review, the applicant shall provide an exterior lighting plan to include specific fixture cut sheets, dimmer switch details, and a photometric study of the Lot demonstrating compliance with the CDC lighting standards.
- 3) Prior to the submittal for a Final Architectural Review, the applicant shall provide a construction mitigation plan.
- 4) Prior to the submittal for a Final Architectural Review, the applicant shall update the materials board with specific finish choices.
- 5) Prior to the submittal for a Final Architectural Review, the applicant shall update window and door specifications to include finish and profile, and shall call out a recess depth for all doors and windows set into stone siding.
- 6) Prior to the submittal for a Final Architectural Review, the applicant shall revise the address monument to include integrated lighting.
- 7) Prior to the submittal for a Final Architectural Review, the applicant shall revise the retaining walls on the south side of the autocourt to meet all CDC guidelines.
- 8) Prior to the issuance of a building permit, a new wetlands delineation is required.
- 9) Prior to the issuance of a building permit, the applicant shall field verify all utilities and submit a revised utility plan to the public works director identifying the location of utilities and connection points.
- 10) Prior to the issuance of a building permit, the applicant shall obtain an easement from TSG to access the sewer line to the west of the home, or submit a revised utility plan to the public works director that provides access from Pennington Place.
- 11) Consistent with town building codes, Unenclosed accessory structures attached to buildings with habitable spaces and projections, such as decks, shall be constructed as either non-combustible, heavy timber or exterior grade ignition resistant materials such as those listed as WUIC (Wildland Urban Interface Code) approved products.
- 12) Prior to issuance of a CO, the property owner will enter into a General Easement Encroachment Agreement, as applicable, with the Town of Mountain Village for the general easement encroachments approved.
- 13) A monumented land survey shall be prepared by a Colorado public land surveyor to establish the maximum building height and the maximum average building height.
- 14) A monumented land survey of the footers will be provided prior to pouring concrete to determine there are no additional encroachments into the GE.
- 15) Prior to the Building Division conducting the required framing inspection, a four-foot (4') by eight-foot (8') materials board will be erected on site consistent with the review authority approval to show:
  - a. The stone, setting pattern and any grouting with the minimum size of four feet (4') by four feet (4');
  - b. Wood that is stained in the approved color(s);
  - c. Any approved metal exterior material;
  - d. Roofing material(s); and
  - e. Any other approved exterior materials

/aw

Lot 729 R-5 Materials



Stone Veneer blend between these two images



Lot 729 R-5 Materials



Stained Wood siding similar to these images

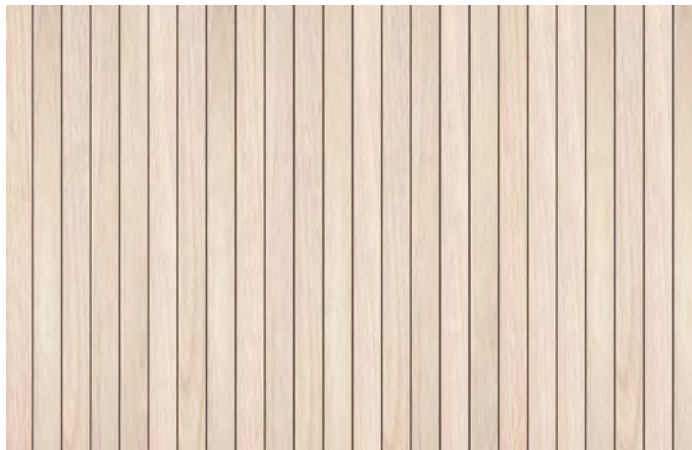

Lot 729 R-5 Materials



Steel Plate Metal Siding

Standing Seam Metal Roofing - Charcoal Grey





### Standard Colors



### Premium Colors

Berridge premium colors require a nominal surcharge.



### Metallic Colors

Berridge metallic colors are premium finishes which require a nominal surcharge.



#### Natural Metal Finish

Berridge Acrylic-Coated Galvalume® is a coated sheet product that combines the corrosion resistance of Galvalume® steel sheet with a clear, organic resin applied to the top side and bottom side of Galvalume® substrate.



Acrylic-Coated Galvalume®

Please consult the BMC Technical department at Technical@Berridge.com for LEED and Energy Star compliance information. Due to limitations in the printing process, please request actual color chips for accurate color viewing.



Energy Star is only valid in the United States.



Lot 729 R-5 Materials



Fascia - Metal and Wood

### GENERAL NOTES

- THE CONTRACT DOCUMENTS INCLUDE THE CONTRACTUAL AGREEMENT, THE DRAWINGS, & THE PROJECT MANUAL (SPECIFICATIONS, SUPPLEMENTAL DRAWINGS, ADDENDA, & PRODUCT CUT SHEETS).
- ALL REQUIRED WORK SHALL BE PERFORMED BY THE GENERAL CONTRACTOR, UNLESS OTHERWISE NOTED. ALL REFERENCES TO THE CONTRACTOR INCLUDE THE GENERAL CONTRACTOR AND HIS SUBCONTRACTORS; THEY SHALL BE ONE AND THE SAME.
- THE CONTRACTOR SHALL OBTAIN ALL APPLICABLE BUILDING PERMITS, ALL NECESSARY INSPECTIONS, & THE CERTIFICATE OF OCCUPANCY.
- THE CONTRACTOR IS RESPONSIBLE FOR THE CONFORMANCE OF ALL WORK TO ANY AND ALL APPLICABLE BUILDING CODES (INCLUDING PLUMBING AND ELECTRICAL). ANY DISCREPANCIES OR NONCONFORMING ITEMS FOUND IN THE DRAWINGS MUST BE IMMEDIATELY BROUGHT TO THE ATTENTION OF THE ARCHITECT.
- IMMEDIATELY FOLLOWING THE AWARDING OF THE CONTRACT, THE CONTRACTOR SHALL SUBMIT A CONSTRUCTION SCHEDULE. ANY AND ALL CHANGES OR SUBMITTALS AFFECTING CONSTRUCTION COST OR SCHEDULE SHALL BE SUBMITTED TO THE ARCHITECT FOR APPROVAL. ANY DISCREPANCIES OR NONCONFORMING ITEMS FOUND IN THE DRAWINGS MUST BE IMMEDIATELY BROUGHT TO THE ATTENTION OF THE ARCHITECT.
- THE CONTRACTOR IS RESPONSIBLE FOR SUBMITTING TO THE ARCHITECT ALL SHOP DRAWINGS AND FINISH MATERIAL SAMPLES ALLOWING ADEQUATE TIME FOR REVIEW, APPROVAL OR CORRECTIONS SO AS NOT TO ADVERSELY AFFECT THE CONSTRUCTION SCHEDULE.
- THE CONTRACTOR SHALL COORDINATE ALL WORK PERFORMED BY THE VARIOUS SUB-CONTRACTORS, AND SHALL VERIFY AND COORDINATE ALL OPENINGS THROUGH FLOORS, WALLS AND CEILINGS WITH ARCHITECTURAL, STRUCTURAL, MECHANICAL & ELECTRICAL DRAWINGS.
- THE CONTRACTOR IS RESPONSIBLE FOR THE PROTECTION OF ALL MATERIALS BEING DELIVERED TO THE PROJECT, THE PROTECTION OF NEIGHBORING PROPERTIES, AND THE COMPLIANCE TO ALL O.S.H.A. REQUIREMENTS.
- THE JOB SITE SHALL BE MAINTAINED IN A CLEAN, ORDERLY MANNER, FREE OF TRASH AND CONSTRUCTION DEBRIS. THE CONTRACTOR SHALL PROVIDE FOR RECYCLING AT THE JOBSITE.
- THE DRAWINGS SHOULD NOT BE SCALED. IF A DIMENSION CAN'T BE DETERMINED THE CONTRACTOR SHALL PROMPTLY CONTACT THE ARCHITECT FOR VERIFICATION.
- IT IS THE CONTRACTOR'S RESPONSIBILITY TO INSURE THAT INSTALLATION METHODS CONFORM TO ALL BUILDING CODE REQUIREMENTS. THE MATERIALS SPECIFIED ARE INTENDED TO MEET CODE REQUIREMENTS. ANY DISCREPANCY BETWEEN THE CONSTRUCTION DOCUMENTS AND CODE REQUIREMENTS SHALL BE BROUGHT TO THE ATTENTION OF THE ARCHITECT IMMEDIATELY BY THE CONTRACTOR PRIOR TO PROCEEDING WITH THE SPECIFIED WORK.
- ELECTRICAL SERVICE, WIRING, ETC. SHALL COMPLY WITH APPLICABLE ELECTRICAL CODES.
- PLUMBING SHALL COMPLY WITH APPLICABLE PLUMBING CODES.
- ALL MATERIALS PROVIDED SHALL CONFORM TO ALL LOCAL, CITY AND/OR COUNTY FIRE REGULATIONS, CERTIFICATES, OR APPROVED FIRE RETARDANT PROCESSING FLAME SPREAD RATINGS, ETC. SHALL BE OBTAINED WITHOUT SPECIFIC REQUEST AND SUBMITTED TO THE ARCHITECT.
- THE DRAWINGS AND SPECIFICATIONS ARE COMPLIMENTARY. WHAT IS REQUIRED BY ONE SHALL BE AS BINDING AS IF REQUIRED BY ALL. WHEN A CONFLICT OCCURS, THE SPECIFICATIONS SHALL HAVE PRECEDENCE.
- NO SUBSTITUTIONS OF SPECIFIED MATERIALS SHALL BE PERMITTED WITHOUT FIRST SUBMITTING SPECIFICATIONS, SAMPLES, AND COST IMPACT FOR ARCHITECT'S APPROVAL.
- THE CONTRACTOR SHALL COORDINATE HIS WORK WITH ALL OTHER TRADES ON THE PROJECT. ANY CHANGES OR DELAYS ARISING FROM CONFLICTS BETWEEN TRADES SHALL BE THE RESPONSIBILITY OF THE CONTRACTOR AT NO ADDITIONAL COST TO THE OWNER.
- AT THE TIME OF BID SUBMITTAL, THE CONTRACTOR SHALL ADVISE THE ARCHITECT (IN WRITING) OF ANY SPECIFIED MATERIALS OR EQUIPMENT WHICH ARE EITHER UNAVAILABLE, OUT OF THE BUDGET OR WILL CAUSE A DELAY IN THE CONSTRUCTION COMPLETION SCHEDULE.
- THE CONTRACTOR SHALL PROVIDE AND INSTALL ROUGH PLUMBING AND FINAL HOOK-UP FOR ALL SPECIFIED FIXTURES AND APPLIANCES, AND SHALL SUPPLY ALL SUCH FIXTURES AND APPLIANCES, UNLESS OTHERWISE NOTED.
- CONTRACTOR SHALL COORDINATE WITH ALL EQUIPMENT MANUFACTURERS FOR EQUIPMENT ROUGH-IN REQUIREMENTS.
- THE CONTRACTOR SHALL VERIFY REQUIRED LOCATIONS OF ALL NECESSARY ACCESS PANELS (IN PARTITIONS, FLOORS, OR CEILINGS) AND COORDINATE EXACT LOCATIONS WITH THE ARCHITECT PRIOR TO INSTALLATION. ALL ACCESS PANELS SHALL BE INSTALLED FLUSH WITH THE SURFACE IN WHICH THEY ARE INSTALLED WITH NO EXPOSED TRIM.
- THE CONTRACTOR SHALL SUPPLY AND INSTALL BLOCKING AND SUPPORTS IN PARTITIONS AND CEILINGS AS REQUIRED FOR INSTALLATION OF SPECIFIED EQUIPMENT, ACCESSORIES, CABINETS, FINISH MATERIALS, AND FIRE BLOCKING (SEE BELOW).
- THE CONTRACTOR SHALL BE RESPONSIBLE FOR SUPPLYING TEMPORARY UTILITIES (POWER, LIGHTING, WATER) TO THE JOB SITE FOR USE BY ALL CONSTRUCTION TRADES, INCLUDING THOSE NOT A SUBCONTRACTOR TO THE GENERAL CONTRACTOR. CONTRACTOR TO PURCHASE WIND OR SOLAR RENEWABLE POWER SOURCES WHEN AVAILABLE.
- FOR WALLS SEPARATING GARAGE AND LIVING SPACE, PROVIDE (1) LAYER 5/8" TYPE 'X' GIB ON EACH SIDE OF STUDS. FOR CEILING FLOORS SEPARATING GARAGE AND LIVING SPACE, PROVIDE (2) LAYERS 5/8" TYPE 'X' GIB AT CEILING. FOR CEILING OF STORAGE AREA BELOW STAIRS, PROVIDE (2) LAYERS 5/8" TYPE 'X' GIB AT CEILING.
- CONTRACTOR IS RESPONSIBLE FOR VERIFICATION OF ALL MATERIAL TAKE-OFFS DONE BY SUB-CONTRACTORS.

#### GENERAL FIREBLOCKING NOTES

- FIRE BLOCKS SHALL BE PROVIDED IN THE FOLLOWING LOCATIONS: (CONTRACTOR SHALL VERIFY WITH CURRENT CODES)
- IN CONCEALED SPACES OF STUD WALLS AND PARTITIONS, INCLUDING FURRED SPACES, AT CEILING AND FLOOR LEVELS.
  - IN CONCEALED SPACES OF STUD WALLS AND PARTITIONS, INCLUDING FURRED SPACES, AT 10-FOOT INTERVALS ALONG THE LENGTH OF THE WALL.
  - AT ALL INTERCONNECTIONS BETWEEN CONCEALED VERTICAL AND HORIZONTAL SPACES SUCH AS OCCUR AT SOFFITS, DROP CEILING AND COVE CEILING.
  - IN CONCEALED SPACES BETWEEN STAIR STRINGERS AT THE TOP AND BOTTOM OF THE RUN AND BETWEEN STUDS ALONG AND IN LINE WITH THE RUN OF THE STAIRS IF THE WALLS UNDER THE STAIRS ARE UNFINISHED.
  - IN OPENINGS AROUND VENTS, PIPES, DUCTS, CHIMNEYS, FIREPLACES AND SIMILAR OPENINGS THAT AFFORD A PASSAGE FOR FIRE AT CEILING AND FLOOR LEVELS, WITH NON-COMBUSTIBLE MATERIALS.
  - AT OPENINGS BETWEEN ATTIC SPACES AND CHIMNEY CHASES FOR FACTORY-BUILT CHIMNEYS.

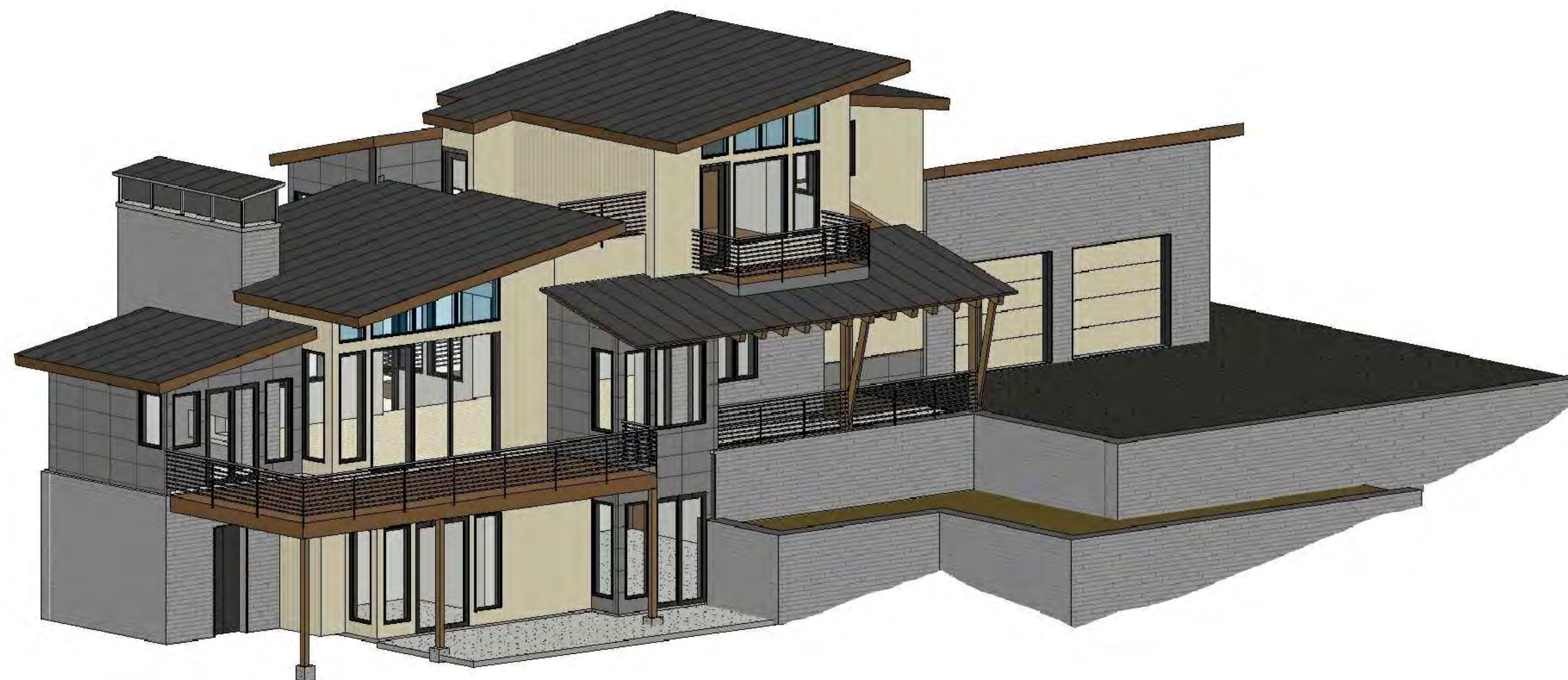

### VICINITY MAP



### GRAPHIC SYMBOLS LEGEND

DRAWING NO.	BUILDING SECTION TAG	WINDOW MARK	DETAIL SHEET
SHEET NO.	INTERIOR ELEVATION TAG	DOOR MARK	DETAIL REFERENCE OR TAG
TO SUBFLOOR ELEVATION DATUM	REVISION AND A.S.I. NUMBER	ROOM NUMBER	
CMU CUT IN PLAN/SECTION	STONE CUT IN PLAN/SECTION	CONCRETE	MORTAR/TEXTURED BED

### PROJECT INFORMATION

**LEGAL DESCRIPTION:**  
 91 PENNINGTON PLACE  
 LOT 729 R-5  
 MOUNTAIN VILLAGE, CO 81435

**BLDG. OCCUPANCY:** RESIDENTIAL = R-3

**CONSTRUCTION:** VB

**DESCRIPTION:**  
 3 STORY SINGLE FAMILY RESIDENCE

MAIN LEVEL = 1,509.0 SF	DECKS = 660 SF
LOWER LEVEL = 1,723.7 SF (143.3 sf mech incl.)	PATIOS = 750 SF
UPPER LEVEL = 661.2 SF	DECKS = 222 SF
<b>TOTAL LIVING = 3,893.9 SF + 649 SF GARAGE = 4,542.9 SF GROSS BUILDING</b>	

### SHEET INDEX

A1-0	TITLE SHEET SITE SURVEY WITH SLOPES
A2-1	SITE PLAN
1 of 3	DRB GRADING PLAN
2 of 3	DRB DRAINAGE & EROSION CONTROL PLAN
3 of 3	DRB UTILITY PLAN
A3-1	MAIN LEVEL FLOOR PLAN
A3-2	LOWER LEVEL FLOOR PLAN
A3-3	UPPER LEVEL FLOOR PLAN
A3-4	ROOF PLAN
A4-1	EXTERIOR ELEVATIONS
A4-2	EXTERIOR ELEVATIONS
A4-3	EXTERIOR ELEVATIONS
A4-4	EXTERIOR ELEVATIONS - MAX AVE. HT. CALCS
A4-5	EXTERIOR ELEVATIONS - MAX AVE. HT. CALCS
A4-6	EXTERIOR ELEVATIONS - MATERIAL CALCS
A4-7	EXTERIOR ELEVATIONS - MATERIAL CALCS
A4-8	EXTERIOR ELEVATIONS - MATERIAL CALCS
A10-1	LOWER LEVEL EXTERIOR ELECTRICAL/LIGHTING PLAN
A10-2	MAIN LEVEL EXTERIOR ELECTRICAL/LIGHTING PLAN
A10-3	UPPER LEVEL EXTERIOR ELECTRICAL/LIGHTING PLAN

### ISSUE DATES

REVIEW SET	12-22-2020
------------	------------

### PROJECT TEAM

SURVEYOR	CIVIL ENGINEER	MECHANICAL ENGINEER	STRUCTURAL ENGINEER	GENERAL CONTRACTOR
SAN JUAN SURVEYING 1600 SOCIETY DRIVE TELLURIDE, CO 81435  (970) 728-1128	ALPINE LAND CONSULTING P.O. BOX 234 RICO, CO 81332  (970) 708-0326	T.B.D.	T.B.D.	ALLISON CONSTRUCTION 1075 SHERMAN ST. #20 P.O. BOX 498 RIDGWAY, CO 81432  (970) 626-5143 OFFICE

COPYRIGHT 2020

REVISIONS:

BACCICH RESIDENCE

LOT 729 R-5

91 PENNINGTON PLACE

MOUNTAIN VILLAGE

SAN MIGUEL COUNTY

PROJECT: #2008

DATE: DECEMBER 22, 2020

REVIEW SET

SHEET NUMBER: A1-0

TITLESHEET

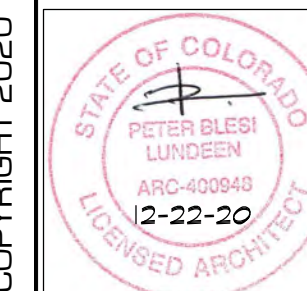

VIEW ANGLE TABLE			
NUMBER	MOUNTAIN PEAK	BEARING	ZENITH ANGLE
L1	CAMPBELL	N18°34'E	78°48'
L2	SAN JOAQUIN	N60°07'E	81°46'
L3	SUNSHINE	S32°38'W	83°41'
L4	WILSON	S50°44'W	83°35'
L5	BLACK MESA	S89°02'W	87°36'
L6	GRAY HEAD	N52°34'W	87°15'

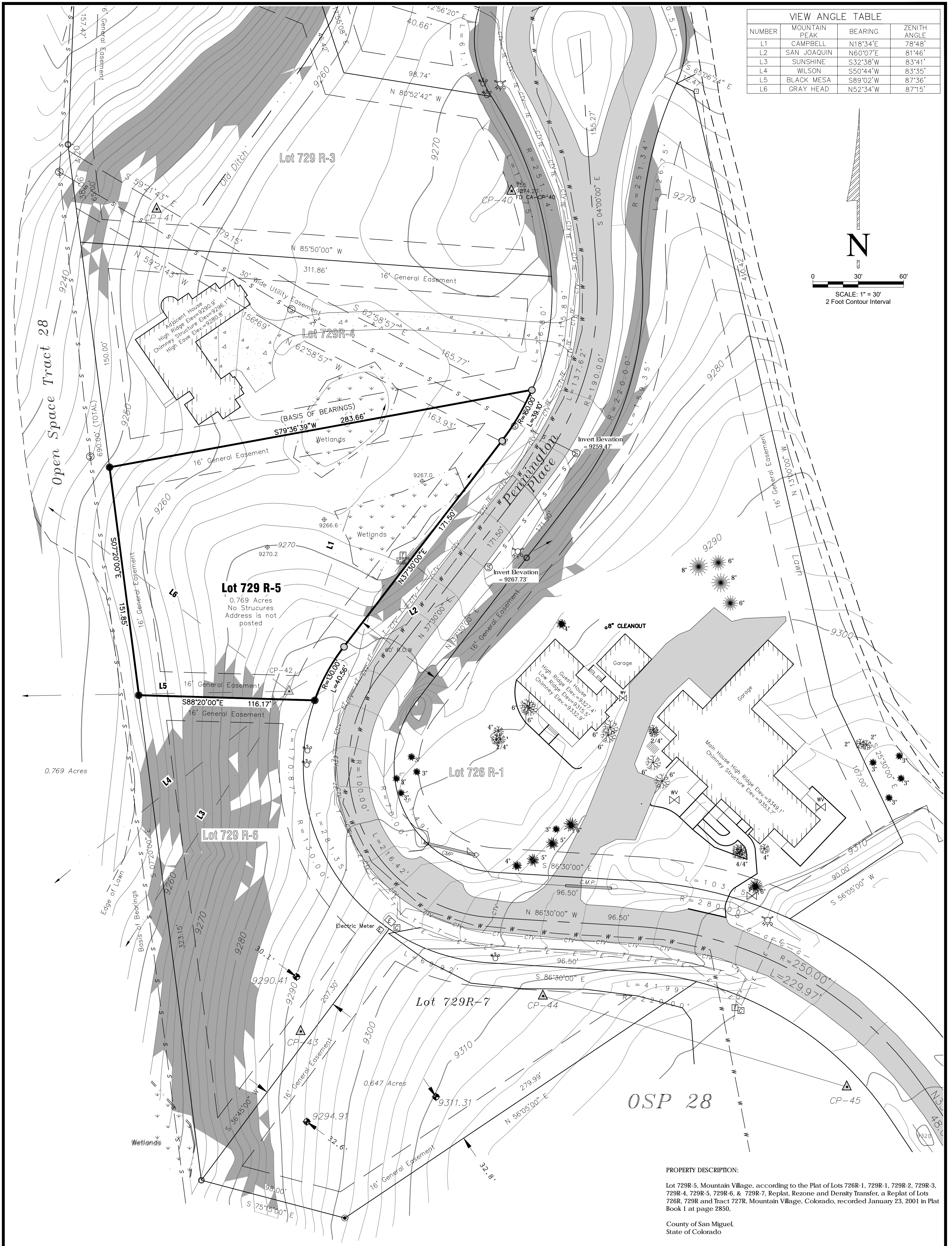
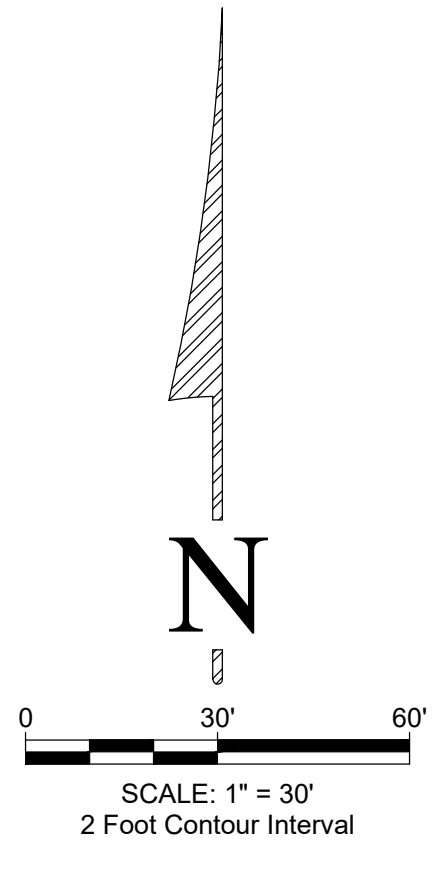

0.769 Acres

0.647 Acres

**LEGEND**

- Found #5 Rebar & 1 1/2" Cap marked Foley L5 24954
- Found Rebar & Cap marked San Juan Surveying L5 28652
- ⊗ Water Valve
- ⊠ Cable Television Pedestal
- ⊡ Telephone Pedestal
- ⊞ Electric Pedestal
- ⊕ Curb Stop
- ⊙ Control Point for View Angle
- ⊛ Fire Hydrant
- ⊚ Sanitary Sewer Manhole
- ⊙ Spruce Tree
- ⊙ Aspen Tree
- ⊙ Fir Tree
- ⊙ Spot Elevation
- E — E — Electric Line
- CTV — CTV — Cable Television Line
- T — T — Telephone Line
- TE — TE — Telephone & Electric Line
- S — S — Sewer Line
- W — W — Water Line
- ▨ Slopes greater than 2%

**NOTICE:**

According to Colorado Law, you must commence any legal action based upon any defect in this survey within three years after you first discover such defect. In no event may any action based upon any defect in this survey be commenced more than ten years from the date of the certification shown hereon.

**NOTES:**

1. According to Flood Insurance Rate Map 08113C0040 C dated September 30, 1992, this parcel lies within Flood Zone "X" (Areas determined to be outside the 500-year flood plain).
2. Easement research from Land Title Guarantee Company, Commitment No. TLR86010347, Effective Date 08/07/2020 at 05:00 PM.
3. Ownership was researched from the county GIS and is for informational purposes only.
4. Utility locates were done by others and located during prior work. No positional accuracy is warranted, order current utility locates prior to excavation.
5. Wetland locations per Plat Book 1 at page 2850
6. Lineal Units U.S. Survey Feet

**PROPERTY DESCRIPTION:**

Lot 729R-5, Mountain Village, according to the Plat of Lots 726R-1, 729R-2, 729R-3, 729R-4, 729R-5, 729R-6, & 729R-7, Replat, Rezone and Density Transfer, a Replat of Lots 726R, 729R and Tract 727R, Mountain Village, Colorado, recorded January 23, 2001 in Plat Book 1 at page 2850.

County of San Miguel  
State of Colorado

**BASIS OF BEARINGS:**

The Basis of Bearings for this Improvement Survey Plat was derived from the south line of Lot 729R-5, according to the Plat recorded in Plat Book 1 at page 2850, said bearing being N 79°36'39" E, both being found monuments as depicted on this plat.

**SURVEYOR'S CERTIFICATE:**

I, Christopher R. Kennedy, of San Juan Surveying, being a Licensed and Registered Land Surveyor in the State of Colorado, do hereby certify that this Improvement Survey Plat prepared for Land Title Guarantee Company, John Baccich and Lisa Baccich, and Sheila M. Timm Revocable Trust was performed under my direct responsibility, supervision, and checking, and that the information herein is true and accurate to the best of my belief and knowledge. I further certify that the monuments as shown were field set as required by Articles 50 and 51 of Title 38, C.R.S.

*Christopher R. Kennedy*  
Christopher R. Kennedy, P.L.S. 36572  
08/17/2020



# IMPROVEMENT SURVEY PLAT LOT 729R-5, MOUNTAIN VILLAGE

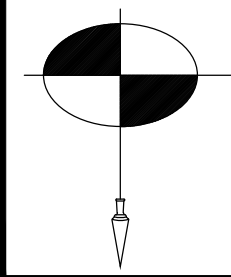

**SAN JUAN SURVEYING**  
SURVEYING \* PLANNING  
102 SOCIETY DRIVE TELLURIDE, CO. 81435  
(970) 728-1128 (970) 728-9201 fax  
office@sanjuansurveying.net

DATE:	08/17/2020
JOB:	00065
DRAWN BY:	ESS
CHECKED BY:	CRK
REVISION DATES:	
SHEET:	1 OF 1

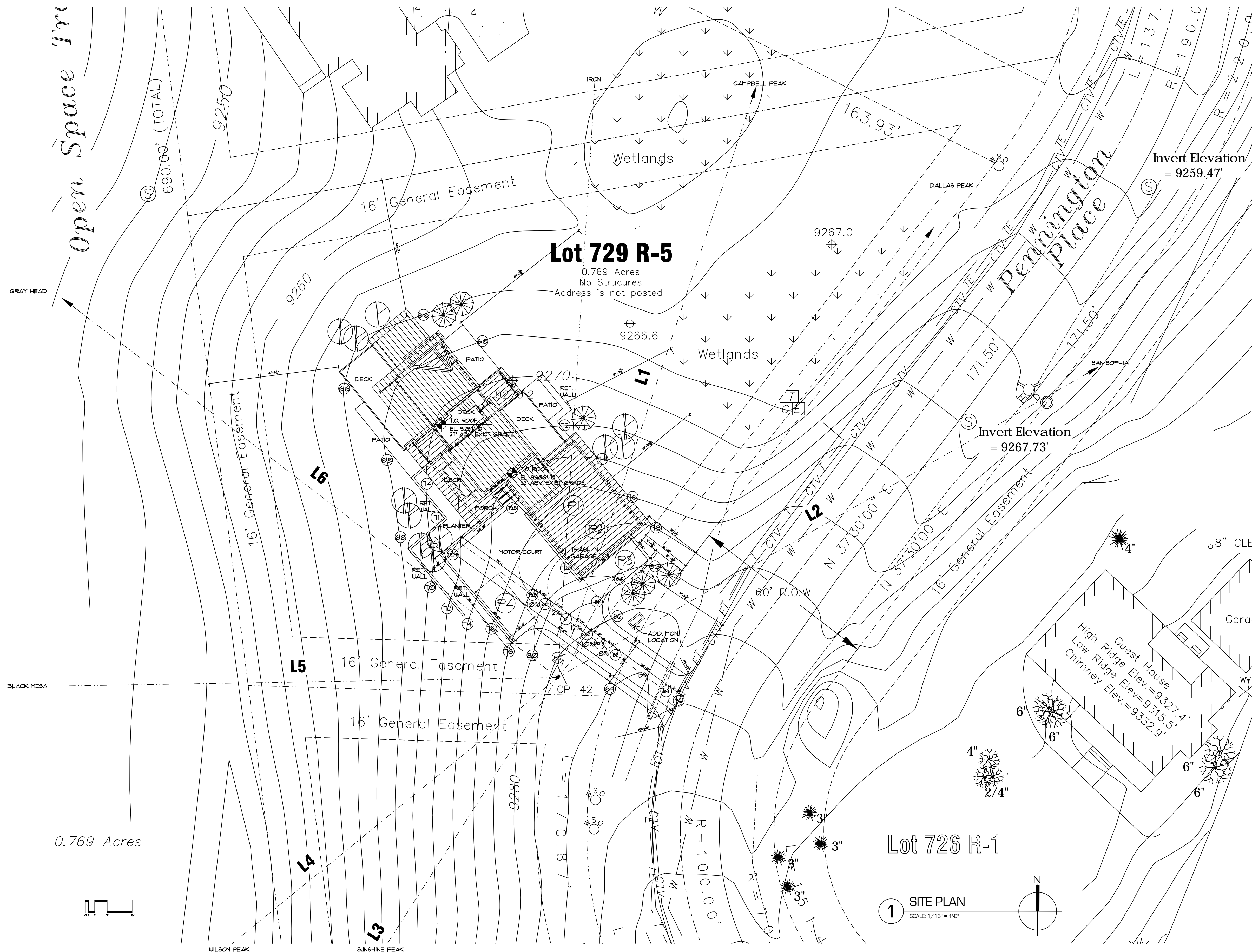

Open Space Tr

**Lot 729 R-5**  
0.769 Acres  
No Structures  
Address is not posted

0.769 Acres

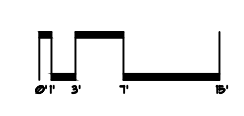

**1** SITE PLAN  
SCALE: 1/16" = 1'-0"

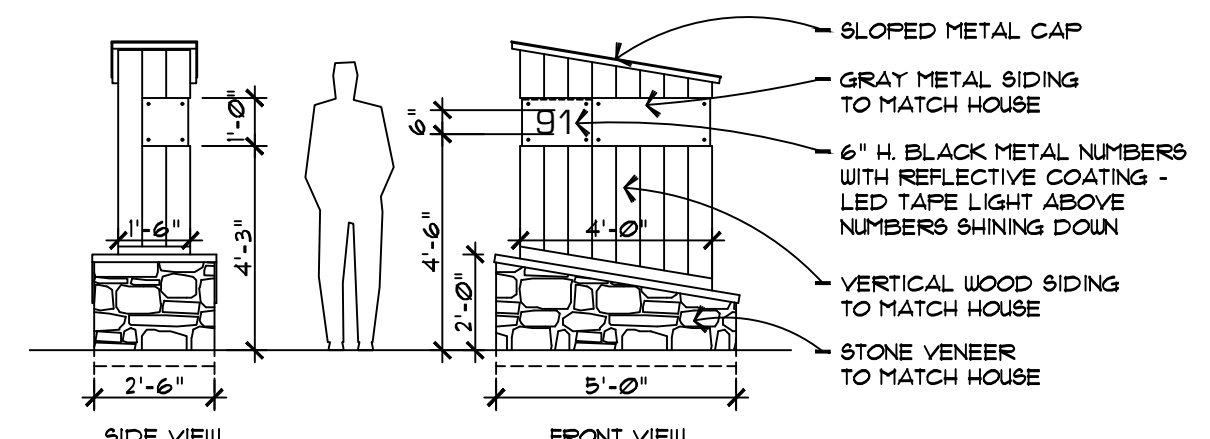

**2** ADDRESS MONUMENT DETAIL  
SCALE: 1/4" = 1'-0"

**SITE LEGEND**

- EXISTING CONTOUR
- REVISED CONTOUR  
CONTOUR INTERVALS 2 FEET
- GAS LINE
- ELECTRIC, CABLE, AND TELEPHONE LINES
- WATER LINE
- SANITARY SEWER LINE
- LINE OF DRAINAGE SWALE
- TREE TO BE REMOVED
- PARKING SPACE
- EXTERIOR LIGHTING
- GAS VALVE
- WATER VALVE
- CABLE TELEVISION PEDESTAL
- TELEPHONE PEDESTAL
- ELECTRIC PEDESTAL
- CURB STOP
- CONTROL POINT
- FIRE HYDRANT
- SANITARY SEWER MANHOLE

- GENERAL NOTES**
- SURVEY INFORMATION PROVIDED BY: SAN JUAN SURVEYING 107 SOCIETY DRIVE TELLURIDE, COLORADO 81435 (970) 728-1128
  - CONTRACTOR TO CONFIRM ALL UTILITY LOCATIONS WITH EACH UTILITY AGENCY. ALL UTILITY TRENCHES TO AVOID DISTURBING EXISTING TREES.
  - THE CONTRACTOR SHALL VERIFY BUILDING LOCATION AND FLOOR ELEVATIONS WITH THE OWNER AND ARCHITECT PRIOR TO EXCAVATION.

**Lot 729 R-5**  
91 Pennington Place

**Lot size** 0.769 acre

**Zone District** Single family  
**Zoning Designations** Single family

Floor Area	Lower Level	Mechanical	Main Level	Garage	Upper Level
	1580.4	143.3	1509	649	661.2
	3750.6		792.3	4542.9 gross sq. ft.	

**Lot Coverage**

5,312.0 sq. ft. footprint
0.769 acres
43,560 sq. ft. per acre
33,497.64 sq. ft. lot size
15.9% lot coverage

**Max Build. Height** 34'-8 1/8"  
**Ave. Bldg. Height** 24'-5 3/16"

**Parking** 2 inside  
Required & provided 2 outside

FOR REVIEW ONLY NOT FOR CONSTRUCTION

COPYRIGHT 2020

REVISIONS:

PROJECT: BACCICH RESIDENCE

DATE: DECEMBER 22, 2020

ISSUED FOR: REVIEW SET

SHEET NUMBER: A2-1

SITE PLAN

LOCATION: LOT 729 R-5 91 PENNINGTON PLACE MOUNTAIN VILLAGE SAN MIGUEL COUNTY

220 East Colorado Ave., Suite 218 P.O.Box 3934 Telluride CO 81435. Office: 970-728-0841

FUSE architecture + interior

Lot 729 R-3

Lot 729R-4

Lot 729 R-5

Lot 729 R-6

### NOTES

1. THIS IS A PLANNING DOCUMENT ONLY AND NOT TO BE USED FOR CONSTRUCTION.
2. ALL EXISTING BOUNDARY, UTILITY, AND TOPOGRAPHIC INFORMATION PROVIDED BY SAN JUAN SURVEYING INC ON ISP OF LOT 729-R5 DATED 8/17/2020. CONTACT CHRIS KENNEDY AT (970) 728-1128 FOR MORE BENCHMARK INFORMATION. SOME OF THE UTILITY SERVICES LOCATIONS SHOWN ON THIS PLAN ARE FROM MAPPING AS-BUILT INFORMATION ONLY AND NOT CONFIRMED.
3. MAXIMUM SLOPE GRADING TO BE 3(HORIZONTAL):1(VERTICAL).
4. ALL RETAINING WALL HEIGHTS AREA FINISHED GRADE TO FINISHED GRADE (RETAINED HEIGHT) AND DO NOT INCLUDE FOUNDATIONS OR CAPS.
5. RETAINING WALLS WITH PEDESTRIAN ACCESS REQUIRE HARD RAILS FOR ALL RETAINED HEIGHT AT OR OVER 2.5' (SEE ARCHITECTURAL, STRUCTURAL, AND/OR LANDSCAPE PLANS).

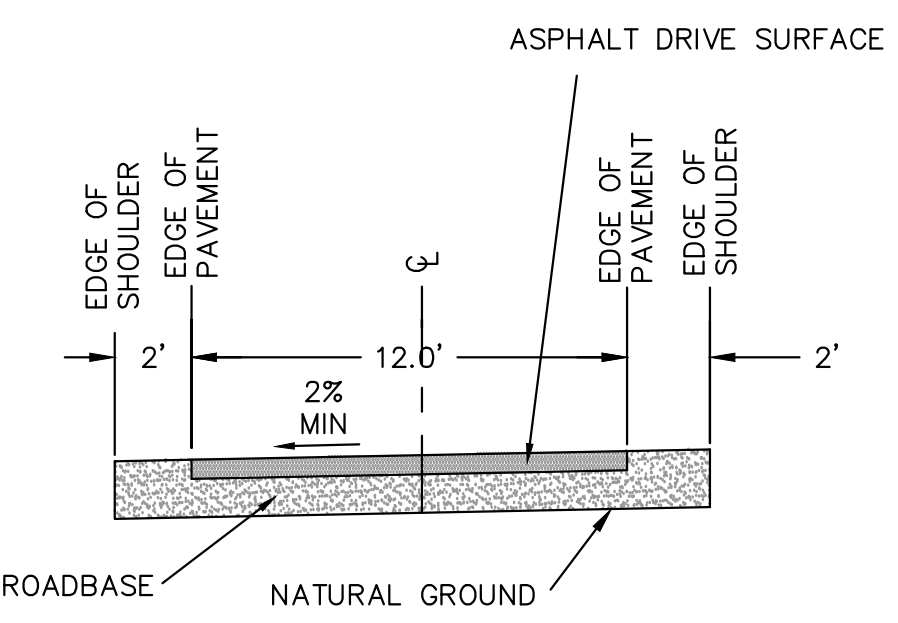

### TYPICAL DRIVEWAY SECTION

NTS

**FOR DRB ONLY AND NOT FOR CONSTRUCTION**

CALL UTILITY NOTIFICATION CENTER OF COLORADO  
**1-800-922-1987**  
 OR  
**811**  
 CALL 2-BUSINESS DAYS IN ADVANCE BEFORE YOU DIG, GRADE, OR EXCAVATE FOR THE MARKING OF UNDERGROUND MEMBER UTILITIES.

**ALPINE LAND CONSULTING, LLC**  
 P.O. BOX 234  
 RICO, COLORADO 81552  
 970-708-0326  
 GREGG@ALPINELANDCONSULTING.COM

THESE PRELIMINARY DRB PLANNING DOCUMENTS WERE PREPARED BY ME AND UNDER MY DIRECT SUPERVISION ON BEHALF OF ALPINE LAND CONSULTING, LLC FOR JOHN AND LISA BACCICH AND INCLUDES PRELIMINARY DRB PLANNING DESIGN ONLY, AND DOES NOT INCLUDE ANY OTHER PLANNING OR ENGINEERING.



GREGORY E. ANDERSON  
 COLORADO PROFESSIONAL ENGINEER  
 REGISTRATION NO. 35736

**LOT 729 R5 MOUNTAIN VILLAGE**  
 DRB GRADING PLAN

**CLIENT:**  
 JOHN AND LISA BACCICH  
 4347 DUVAL DR  
 JACKSONVILLE BEACH, FL 32250

DATE: DECEMBER 4, 2020

PROJECT #: 2020042

PROJECT MANAGER: GEA  
DRAWN BY: ADM

SHEET #:

# 1 OF 3

NO.	REVISIONS	DATE

### DRB GRADING PLAN

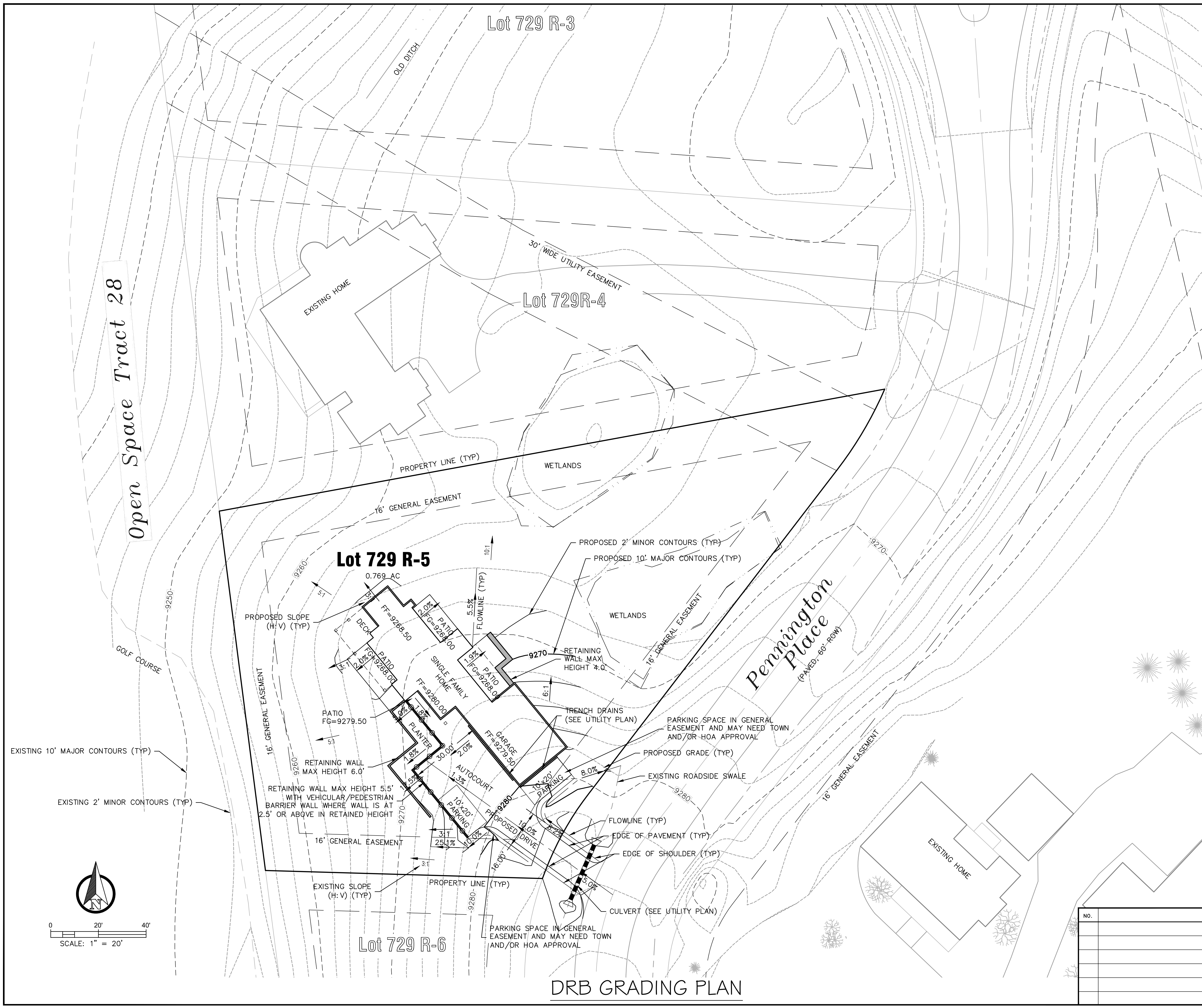

EXISTING 10' MAJOR CONTOURS (TYP)  
 EXISTING 2' MINOR CONTOURS (TYP)

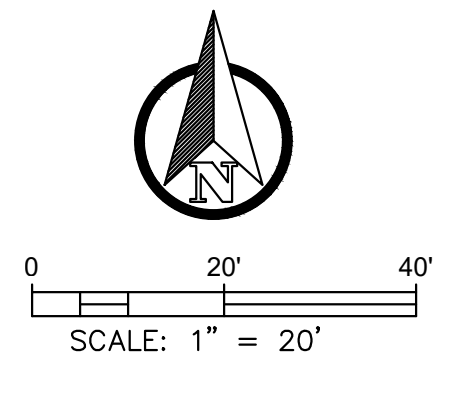

Lot 729 R-3

Lot 729R-4

Lot 729 R-5

Lot 729 R-6

### NOTES

1. THIS IS A PLANNING DOCUMENT ONLY AND NOT TO BE USED FOR CONSTRUCTION.
2. ALL EXISTING BOUNDARY, UTILITY, AND TOPOGRAPHIC INFORMATION PROVIDED BY SAN JUAN SURVEYING INC ON ISP OF LOT 729-R5 DATED 8/17/2020. CONTACT CHRIS KENNEDY AT (970) 728-1128 FOR MORE BENCHMARK INFORMATION. SOME OF THE UTILITY SERVICES LOCATIONS SHOWN ON THIS PLAN ARE FROM MAPPING AS-BUILT INFORMATION ONLY AND NOT CONFIRMED.
3. MAXIMUM SLOPE GRADING TO BE 3(HORIZONTAL):1(VERTICAL).
4. ALL RETAINING WALL HEIGHTS AREA FINISHED GRADE TO FINISHED GRADE (RETAINED HEIGHT) AND DO NOT INCLUDE FOUNDATIONS OR CAPS.
5. RETAINING WALLS WITH PEDESTRIAN ACCESS REQUIRE HARD RAILS FOR ALL RETAINED HEIGHT AT OR OVER 2.5' (SEE ARCHITECTURAL, STRUCTURAL, AND/OR LANDSCAPE PLANS).
6. NO DETENTION IS PLANNED FOR THIS SITE AT THIS TIME.

### LEGEND

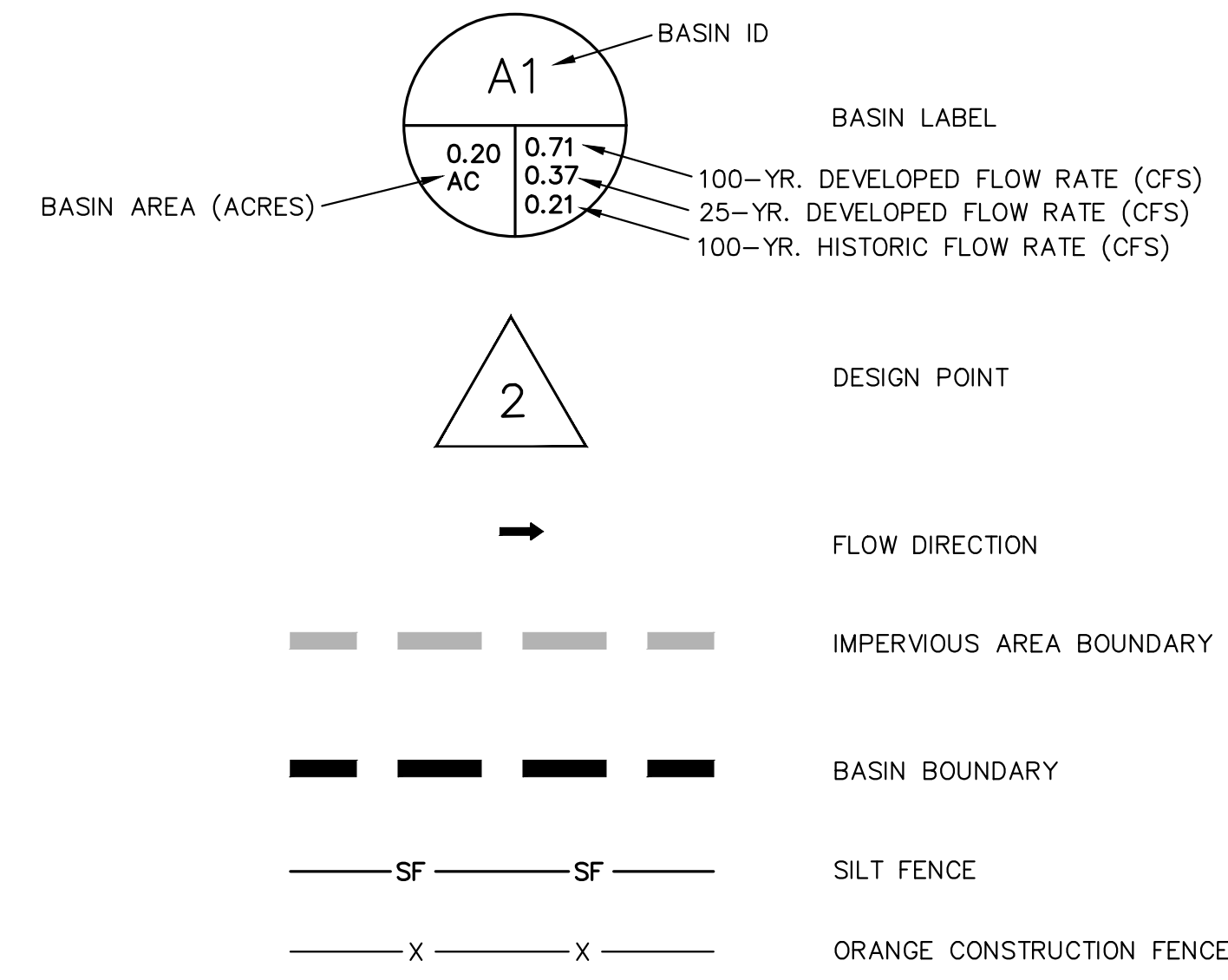

**FOR DRB ONLY AND NOT FOR CONSTRUCTION**

CALL UTILITY NOTIFICATION CENTER OF COLORADO  
**1-800-922-1987**  
OR  
**811**  
CALL 2-BUSINESS DAYS IN ADVANCE BEFORE YOU DIG, GRADE, OR EXCAVATE FOR THE MARKING OF UNDERGROUND MEMBER UTILITIES.

**ALPINE LAND CONSULTING, LLC**  
P.O. BOX 234  
RICO, COLORADO 81552  
970-708-0326  
GREGG@ALPINELANDCONSULTING.COM

THESE PRELIMINARY DRB PLANNING DOCUMENTS WERE PREPARED BY ME AND UNDER MY DIRECT SUPERVISION ON BEHALF OF ALPINE LAND CONSULTING, LLC FOR JOHN AND LISA BACCICH AND INCLUDES PRELIMINARY DRB PLANNING DESIGN ONLY, AND DOES NOT INCLUDE ANY OTHER PLANNING OR ENGINEERING.



GREGORY E. ANDERSON  
COLORADO PROFESSIONAL ENGINEER  
REGISTRATION NO. 35736

**LOT 729 R5 MOUNTAIN VILLAGE**  
DRB DRAINAGE AND EROSION CONTROL PLAN

**CLIENT:**  
JOHN AND LISA BACCICH  
4347 DUVAL DR  
JACKSONVILLE BEACH, FL 32250

DATE: DECEMBER 4, 2020

PROJECT #: 2020042

PROJECT MANAGER: GEA  
DRAWN BY: ADM

SHEET #:

# 2 OF 3

NO.	REVISIONS	DATE

## DRB DRAINAGE AND EROSION CONTROL PLAN

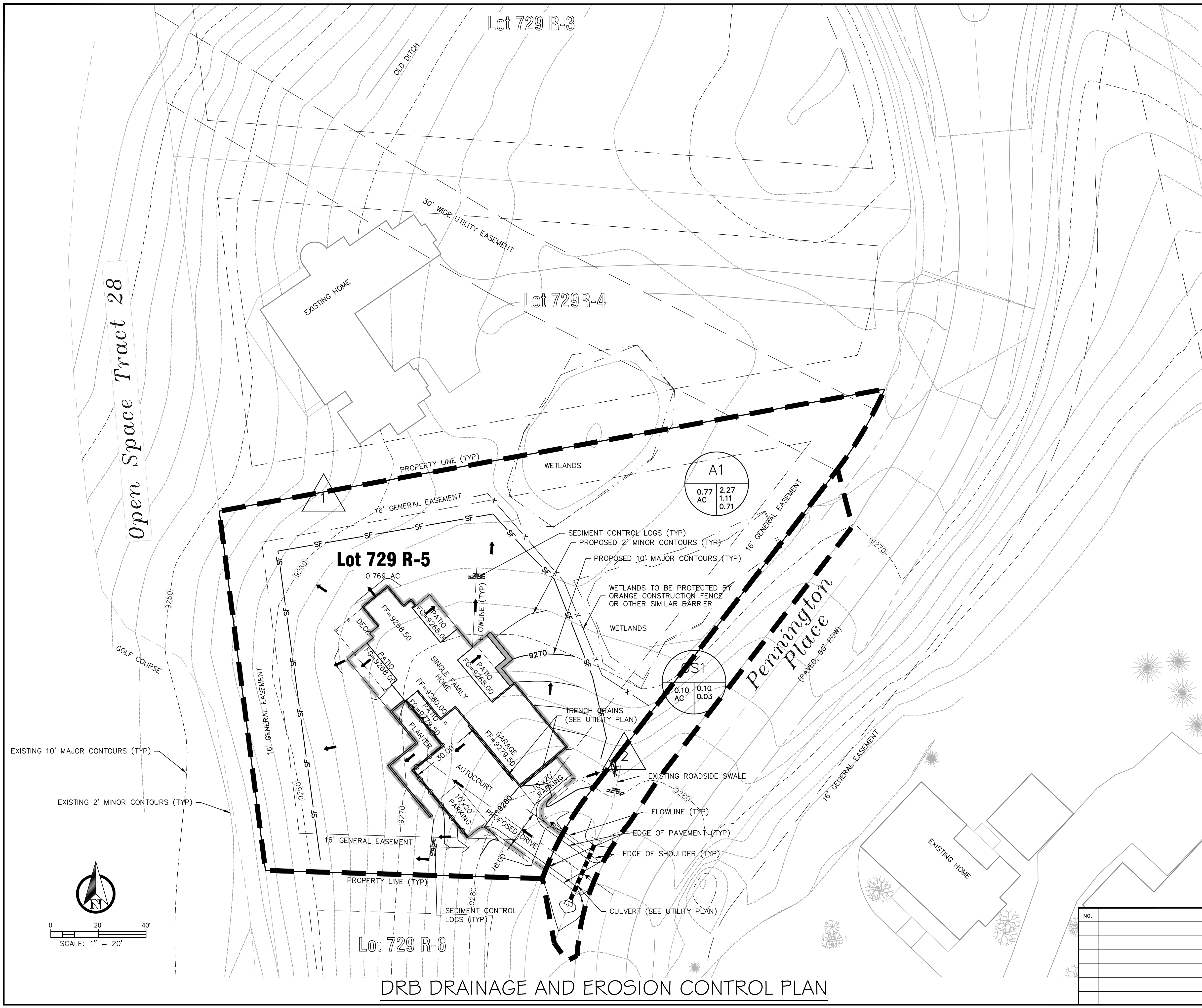

EXISTING 10' MAJOR CONTOURS (TYP)  
EXISTING 2' MINOR CONTOURS (TYP)

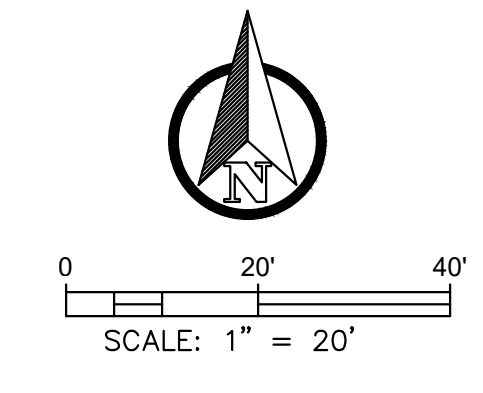

Open Space Tract 28

GOLF COURSE

Pennington Place  
(PAVED, 80' ROW)

Lot 729 R-3

**NOTES**

1. THIS IS A PLANNING DOCUMENT ONLY AND NOT TO BE USED FOR CONSTRUCTION.
2. ALL EXISTING BOUNDARY, UTILITY, AND TOPOGRAPHIC INFORMATION PROVIDED BY SAN JUAN SURVEYING INC ON ISP OF LOT 729-R5 DATED 8/17/2020. CONTACT CHRIS KENNEDY AT (970) 728-1128 FOR MORE BENCHMARK INFORMATION. SOME OF THE UTILITY SERVICES LOCATIONS SHOWN ON THIS PLAN ARE FROM MAPPING AS-BUILT INFORMATION ONLY AND NOT CONFIRMED.
3. ALL UTILITY LOCATES TO BE PERFORMED PRIOR TO FINAL DESIGN. IT IS RECOMMEND THAT THE SEWER TAP IS POT HOLED PRIOR TO FINAL DESIGN IN ORDER TO DETERMINE IF THE SEWER REQUIRES A PUMP IN THE MECHANICAL ROOM.

Open Space Tract 28

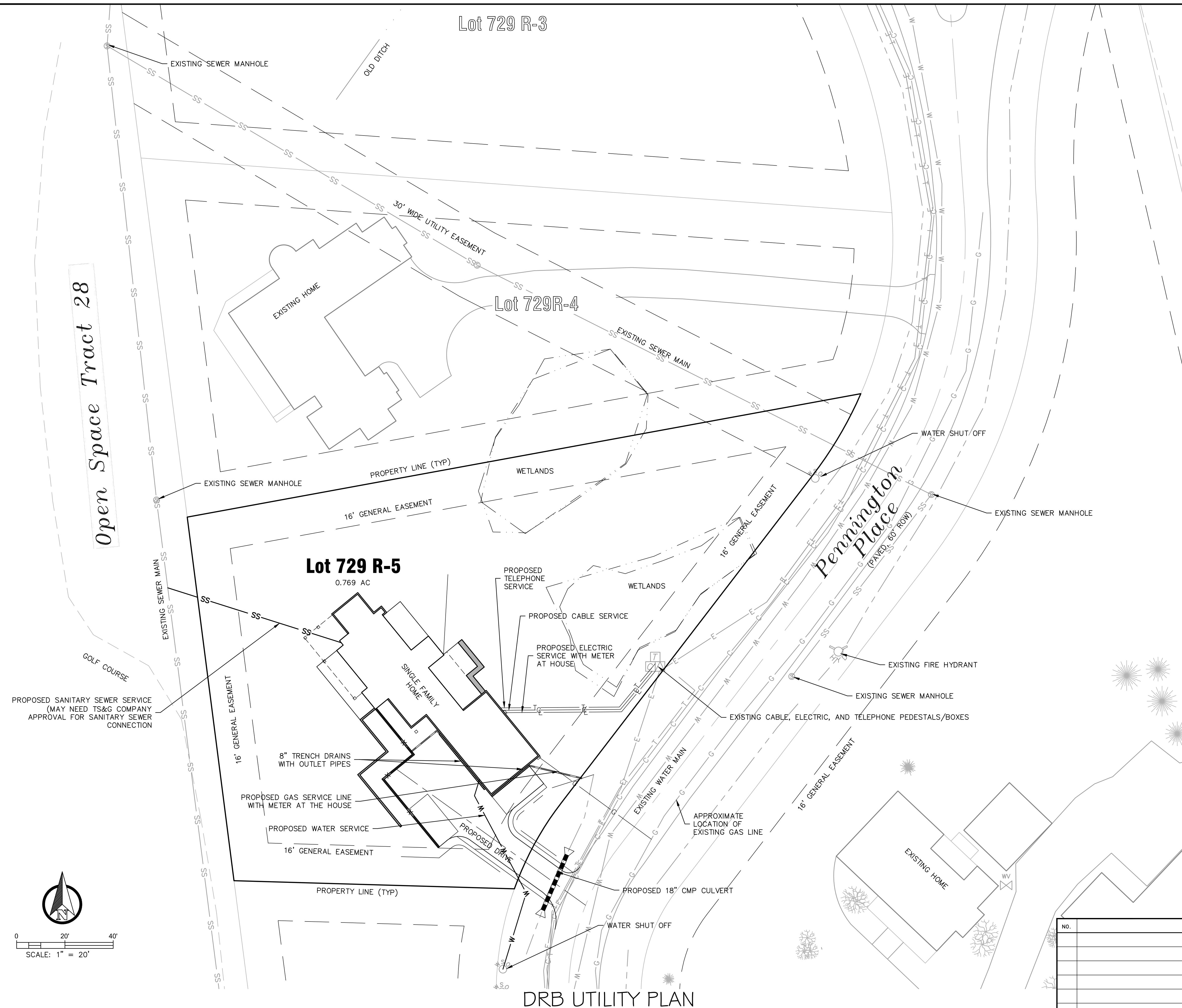

**FOR DRB ONLY AND NOT FOR CONSTRUCTION**

CALL UTILITY NOTIFICATION CENTER OF COLORADO  
**1-800-922-1987**  
 OR  
**811**  
 CALL 2-BUSINESS DAYS IN ADVANCE BEFORE YOU DIG, GRADE, OR EXCAVATE FOR THE MARKING OF UNDERGROUND MEMBER UTILITIES.

**ALPINE LAND CONSULTING, LLC**  
 P.O. BOX 234  
 RICO, COLORADO 81532  
 970-708-0326  
 GREGG@ALPINELANDCONSULTING.COM

THESE PRELIMINARY DRB PLANNING DOCUMENTS WERE PREPARED BY ME AND UNDER MY DIRECT SUPERVISION ON BEHALF OF ALPINE LAND CONSULTING, LLC FOR JOHN AND LISA BACCICH AND INCLUDES PRELIMINARY DRB PLANNING DESIGN ONLY, AND DOES NOT INCLUDE ANY OTHER PLANNING OR ENGINEERING.



GREGORY E. ANDERSON  
 COLORADO PROFESSIONAL ENGINEER  
 REGISTRATION NO. 35736

**LOT 729 R5 MOUNTAIN VILLAGE**  
 DRB UTILITY PLAN

**CLIENT:**  
 JOHN AND LISA BACCICH  
 4347 DUVAL DR  
 JACKSONVILLE BEACH, FL 32250

DATE: DECEMBER 4, 2020

PROJECT #: 2020042

PROJECT MANAGER: GEA  
 DRAWN BY: ADM

SHEET #:

**3 OF 3**

NO.	REVISIONS	DATE

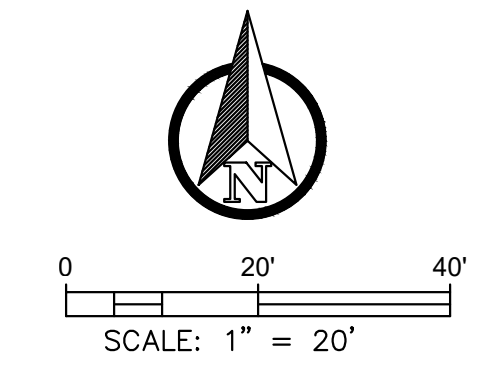

**DRB UTILITY PLAN**

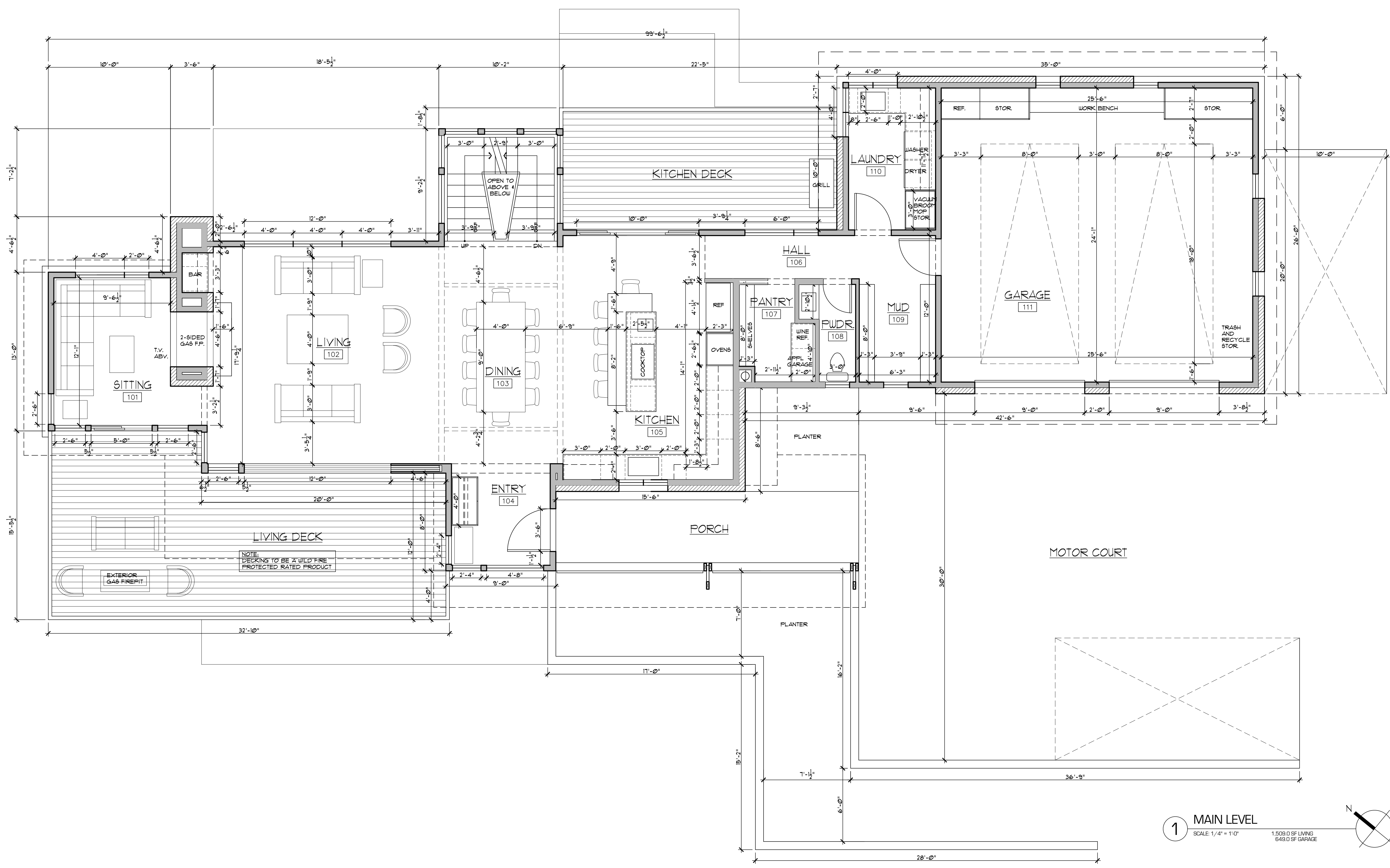

**1 MAIN LEVEL**  
SCALE: 1/4" = 1'-0"  
1,509.0 SF LIVING  
649.0 SF GARAGE

1,509.0 SF	LIVING MAIN
1,723.7 SF	LIVING LOWER
661.2 SF	LIVING UPPER
3,893.9 SF	LIVING TOTAL
649.0 SF	GARAGE
4,542.9 SF	GROSS TOTAL

FOR REVIEW ONLY NOT FOR CONSTRUCTION

DATE: DECEMBER 22, 2020  
ISSUED FOR: REVIEW SET

PROJECT: #2008

**BACCICH RESIDENCE**

REVISIONS:

SHEET NUMBER: **A3-1**  
FLOOR PLAN

LOCATION: LOT 729 R-5 91 PENNINGTON PLACE MOUNTAIN VILLAGE SAN MIGUEL COUNTY

COPYRIGHT 2020

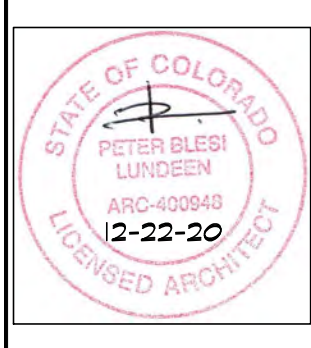



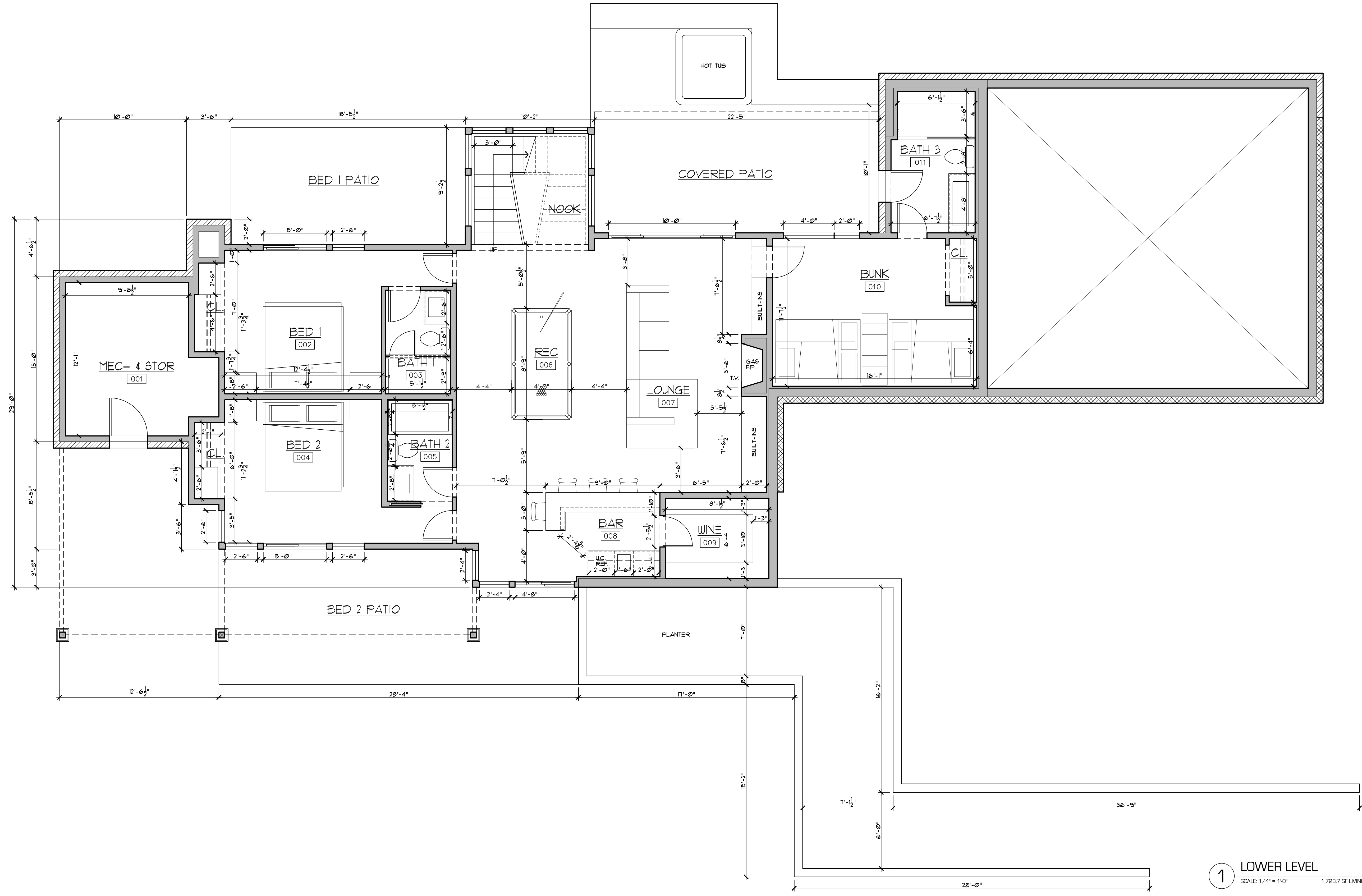

1 LOWER LEVEL  
 SCALE: 1/4" = 1'-0" 1,723.7 SF LIVING

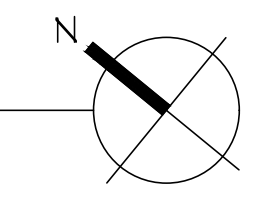

FOR REVIEW ONLY NOT FOR CONSTRUCTION

DATE: DECEMBER 22, 2020  
 ISSUED FOR: REVIEW SET

PROJECT: #2008

SHEET NUMBER: A3-2  
 FLOOR PLAN

LOCATION: LOT 729 R-5 91 PENNINGTON PLACE MOUNTAIN VILLAGE SAN MIGUEL COUNTY

BACCICH RESIDENCE

REVISIONS:

COPYRIGHT 2020

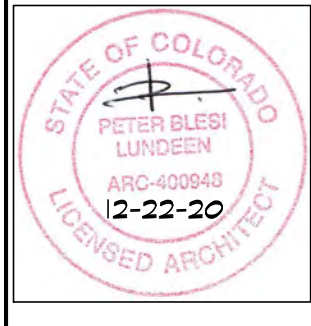

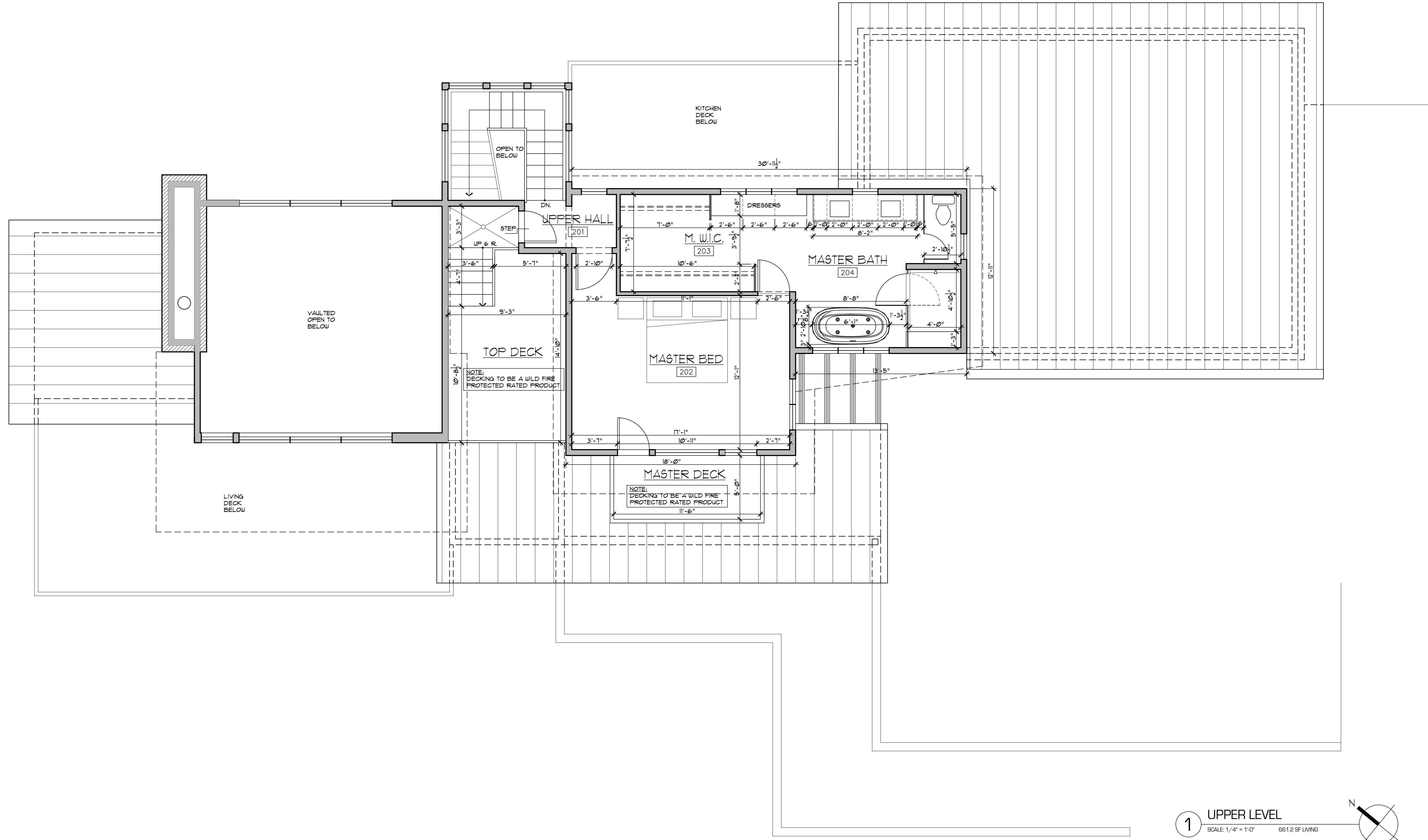

**1** UPPER LEVEL  
 SCALE 1/4" = 1'-0" 661.2 SF LIVING

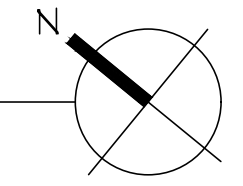

FOR REVIEW ONLY NOT FOR CONSTRUCTION

DATE: DECEMBER 22, 2020  
 ISSUED FOR: REVIEW SET

PROJECT: #2008

SHEET NUMBER: A3-3  
 FLOOR PLAN

LOCATION: LOT 729 R-5 91 PENNINGTON PLACE MOUNTAIN VILLAGE SAN MIGUEL COUNTY

**BACCICH RESIDENCE**

COPYRIGHT 2020

REVISIONS:

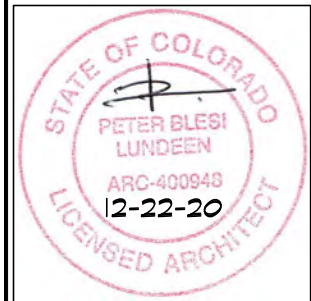

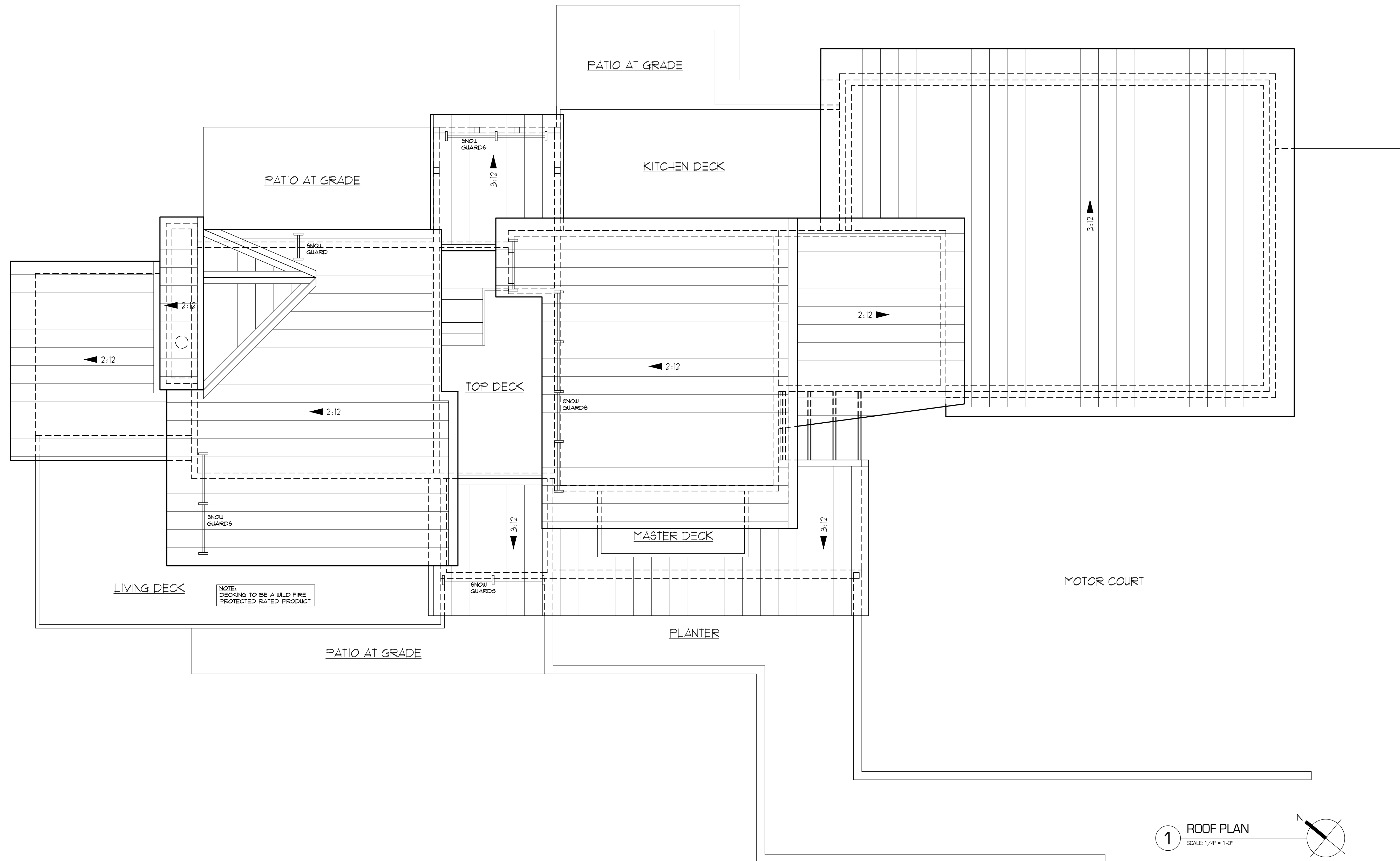

1 ROOF PLAN  
SCALE: 1/4" = 1'0"

FOR REVIEW ONLY NOT FOR CONSTRUCTION

DATE: DECEMBER 22, 2020  
ISSUED FOR: REVIEW SET  
SHEET NUMBER: A3-4  
ROOF PLAN

PROJECT: #2008  
LOCATION: LOT 729 R-5 91 PENNINGTON PLACE MOUNTAIN VILLAGE SAN MIGUEL COUNTY  
BACCICH RESIDENCE

REVISIONS:

COPYRIGHT 2020

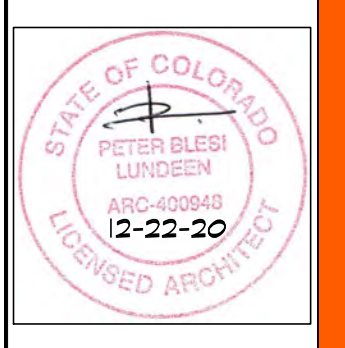

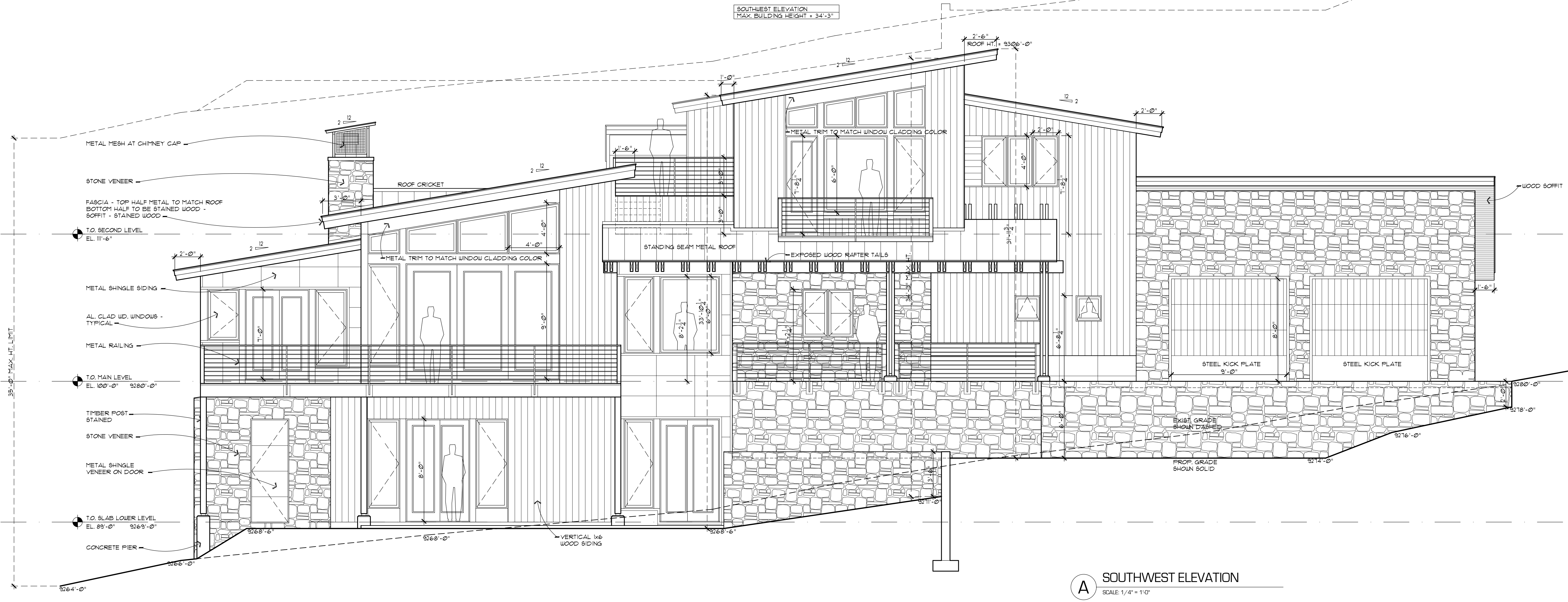

**A** SOUTHWEST ELEVATION  
SCALE 1/4" = 1'-0"

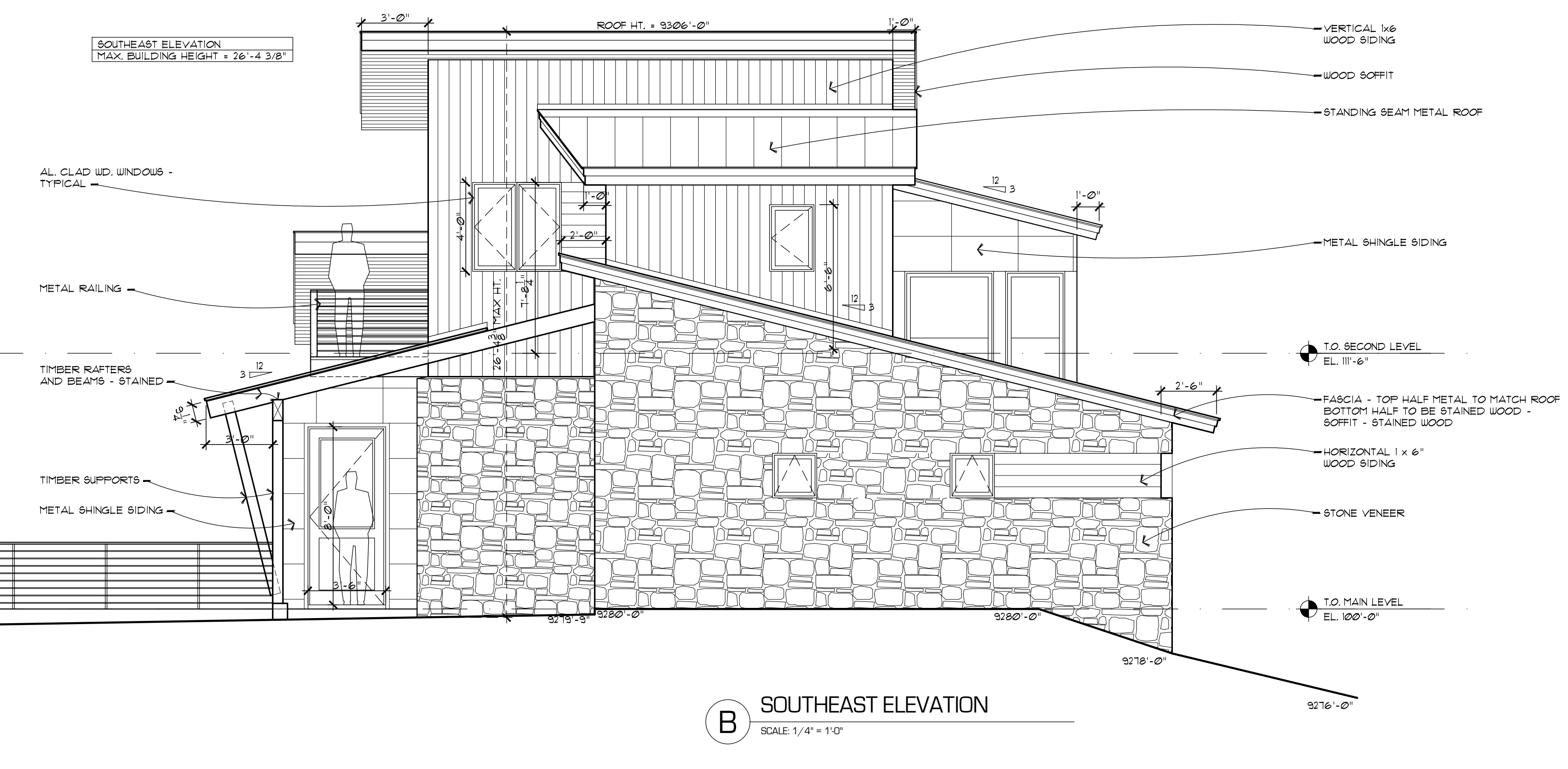
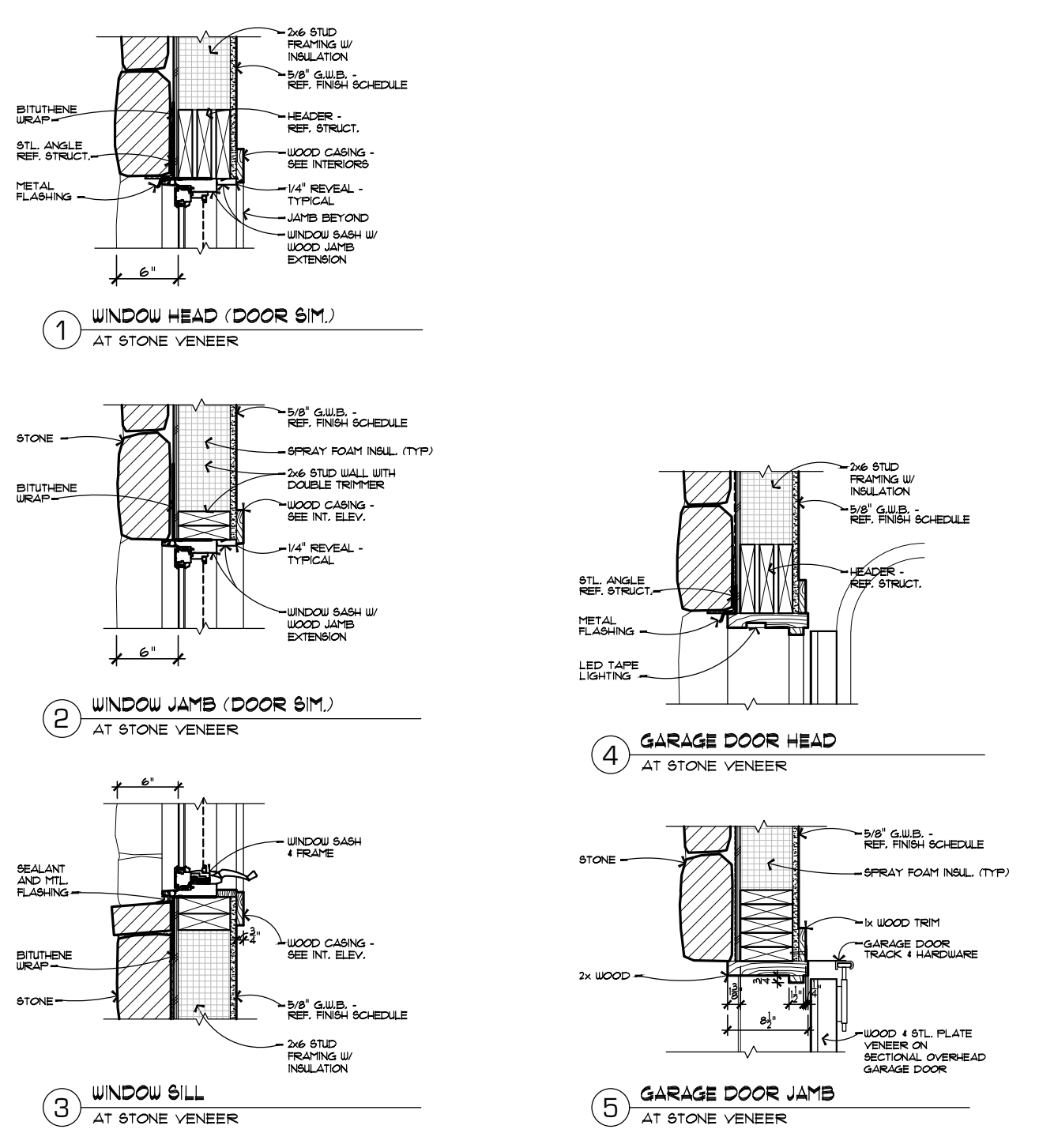

**B** SOUTHEAST ELEVATION  
SCALE 1/4" = 1'-0"

FOR REVIEW ONLY NOT FOR CONSTRUCTION

DATE: DECEMBER 22, 2020  
ISSUED FOR: REVIEW SET

SHEET NUMBER: A4-1  
EXTERIOR ELEVATIONS

PROJECT: #2008

LOCATION: LOT 729 R-5 91 PENNINGTON PLACE MOUNTAIN VILLAGE SAN MIGUEL COUNTY

BACCICH RESIDENCE

REVISIONS:

COPYRIGHT 2020

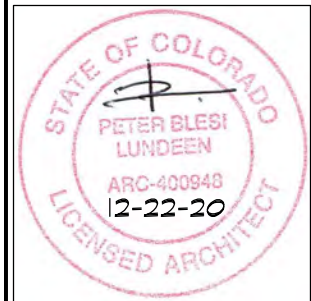

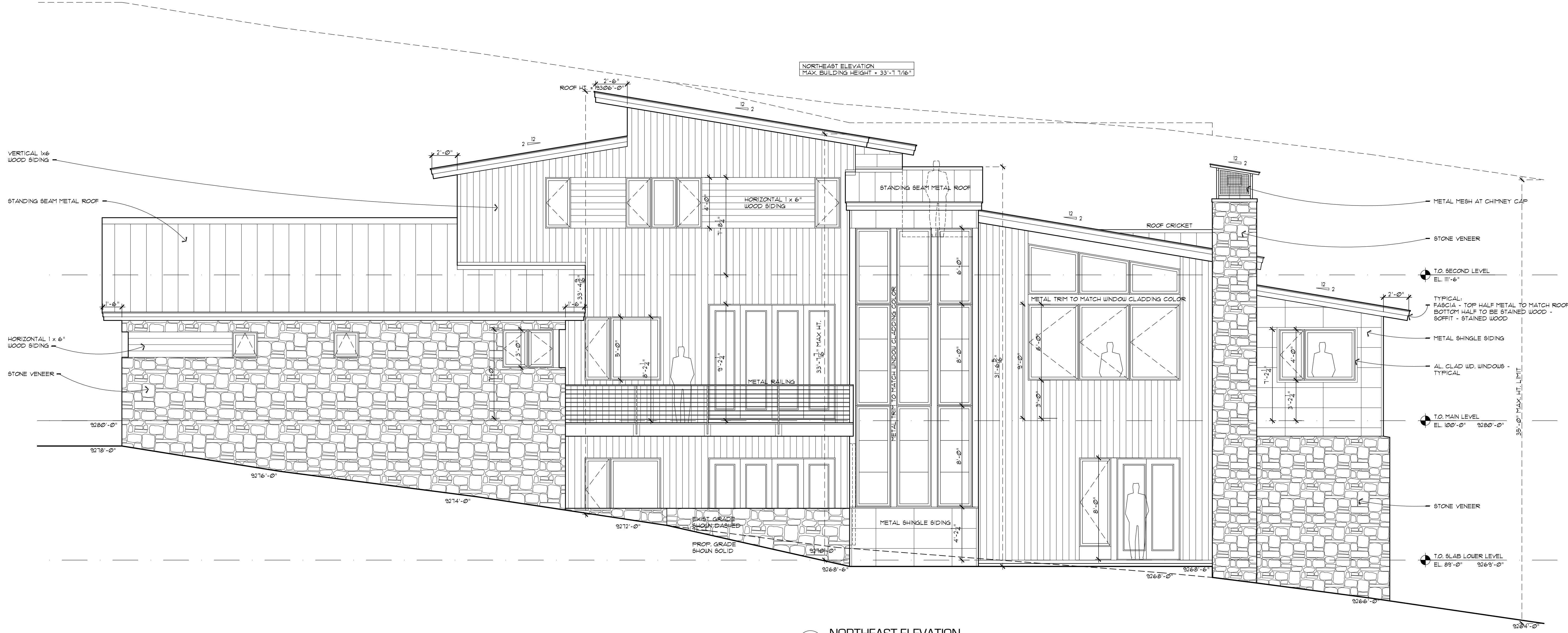

**A** NORTHEAST ELEVATION  
SCALE: 1/4" = 1'-0"

NORTHEAST ELEVATION  
MAX. BUILDING HEIGHT = 33'-1 1/8"

FOR REVIEW ONLY NOT FOR CONSTRUCTION

DATE: DECEMBER 22, 2020  
ISSUED FOR: REVIEW SET

PROJECT: #2008

**BACCICH RESIDENCE**

COPYRIGHT 2020

REVISIONS:

LOCATION: LOT 729 R-5 91 PENNINGTON PLACE MOUNTAIN VILLAGE SAN MIGUEL COUNTY

SHEET NUMBER: **A4-2**  
EXTERIOR ELEVATIONS

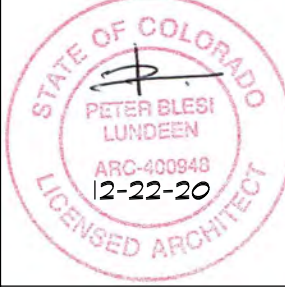

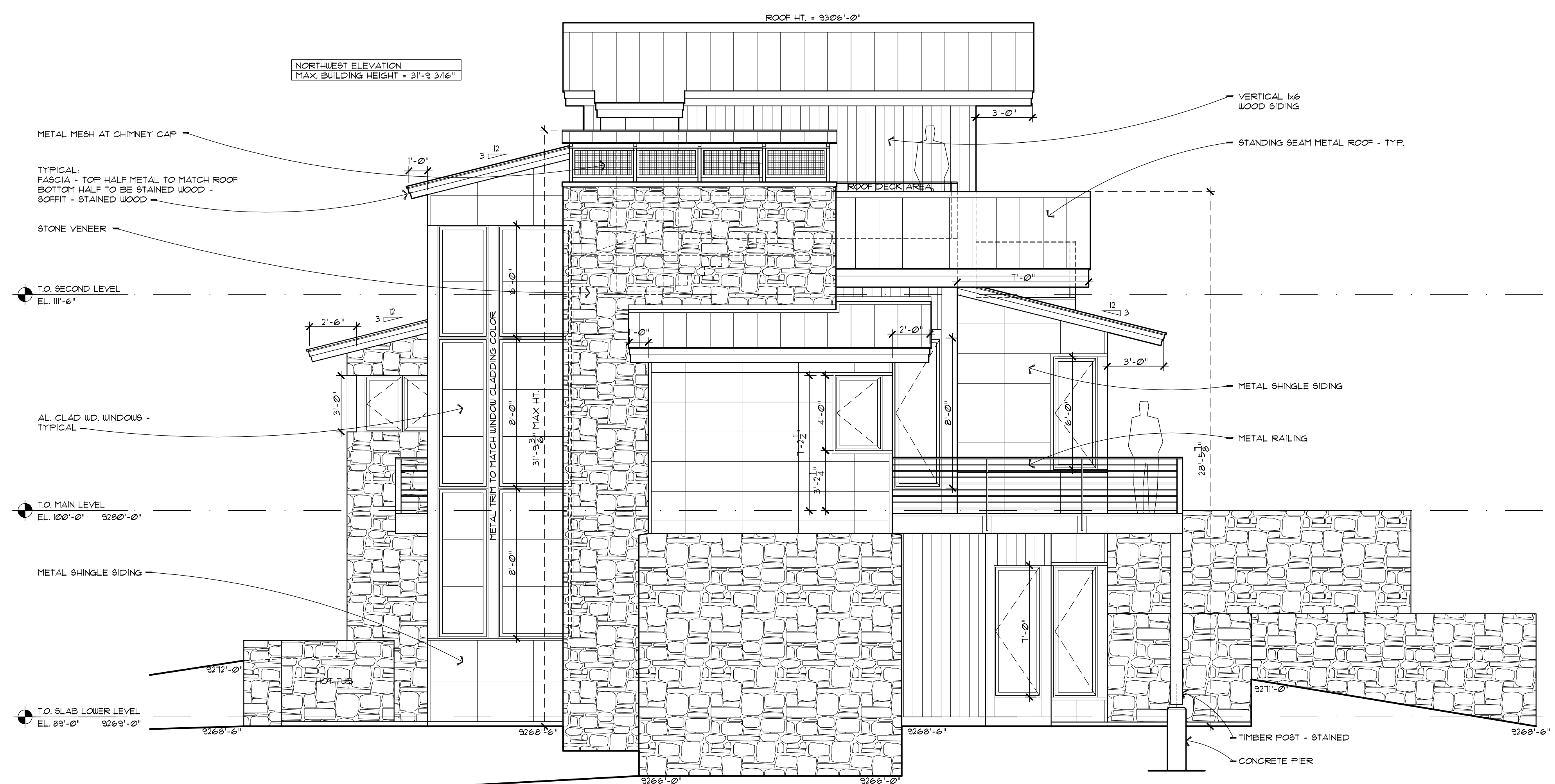

**A NORTHWEST ELEVATION**  
SCALE: 1/4" = 1'-0"

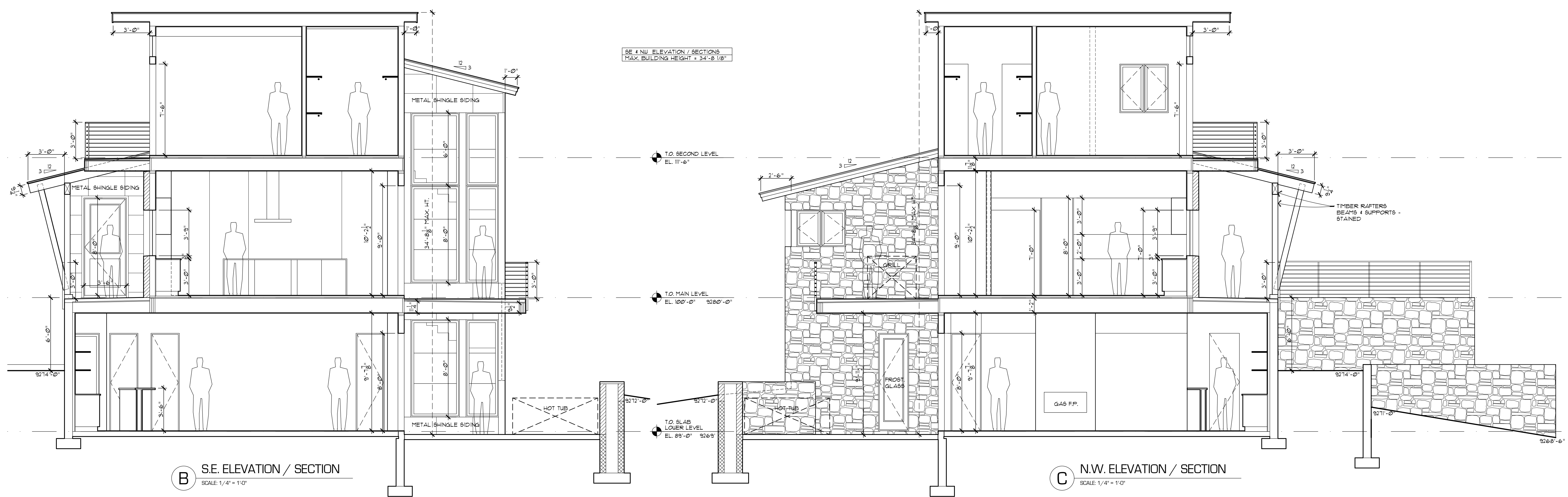

**B S.E. ELEVATION / SECTION**  
SCALE: 1/4" = 1'-0"

**C N.W. ELEVATION / SECTION**  
SCALE: 1/4" = 1'-0"

FOR REVIEW ONLY NOT FOR CONSTRUCTION

DATE: DECEMBER 22, 2020  
ISSUED FOR: REVIEW SET

PROJECT: #2008

BACCICH RESIDENCE

REVISIONS:

SHEET NUMBER: A4-3  
EXTERIOR ELEVATIONS

LOCATION: LOT 729 R-5 91 PENNINGTON PLACE MOUNTAIN VILLAGE SAN MIGUEL COUNTY

FUSE architecture + interior

220 East Colorado Ave., Suite 218 P.O.Box 3984 Telluride CO 81435. Office: 970-728-0841

COPYRIGHT 2020

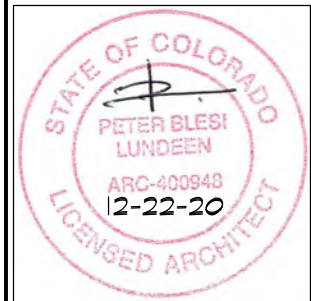



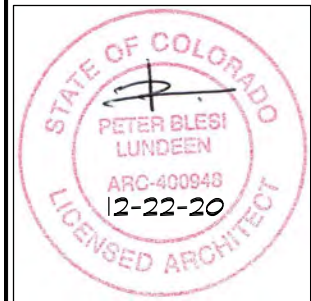

REVISIONS:

**BACCICH RESIDENCE**

PROJECT: #2008  
 LOCATION: LOT 729 R-5 91 PENNINGTON PLACE MOUNTAIN VILLAGE SAN MIGUEL COUNTY

FOR REVIEW ONLY NOT FOR CONSTRUCTION

DATE: DECEMBER 22, 2020  
 ISSUED FOR: REVIEW SET

SHEET NUMBER: A4-5  
 EXTERIOR ELEVATIONS

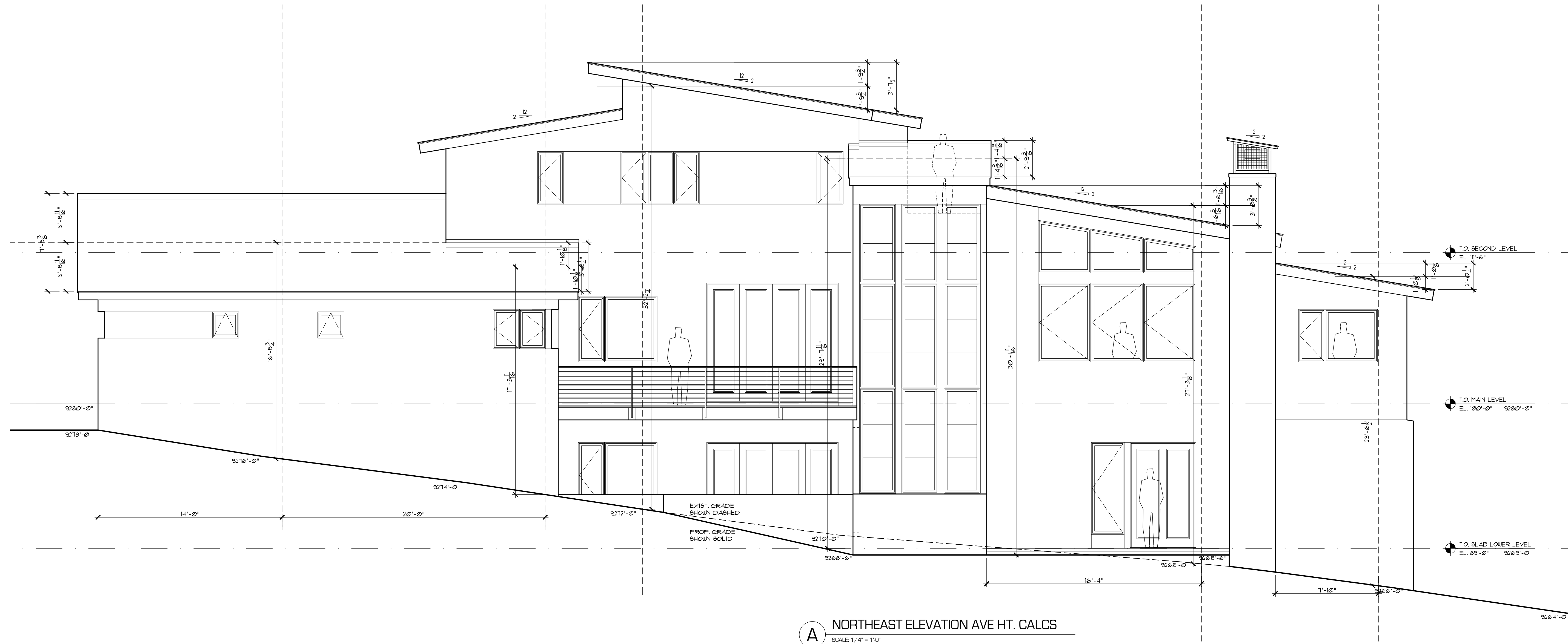

**A** NORTHEAST ELEVATION AVE HT. CALCS  
 SCALE: 1/4" = 1'-0"

Ave Roof Height	feet	inches	inch in feet	total in feet
16'-7 1/4"	16	7.25	0.60	16.60
12'-3 1/2"	12	3.5	0.29	12.29
16'-5 3/4"	16	5.75	0.48	16.48
17'-3 3/4"	17	3.75	0.31	17.31
32'-2 1/4"	32	2.25	0.19	32.19
29'-7 3/4"	29	7.75	0.65	29.65
30'-1 3/4"	30	1.75	0.15	30.15
27'-3 1/8"	27	3.125	0.26	27.26
23'-6 1/2"	23	6.5	0.54	23.54
23'-3 5/8"	23	3.625	0.30	23.30
26'-7 3/8"	26	7.375	0.61	26.61
26'-0"	26	0	0.00	26.00
32'-10"	32	10	0.83	32.83
32'-4 1/4"	32	4.25	0.35	32.35
19'-10"	19	10	0.83	19.83
<b>24'-5 3/16"</b>			<b>ave height</b>	<b>366.41</b> <b>24.43</b>

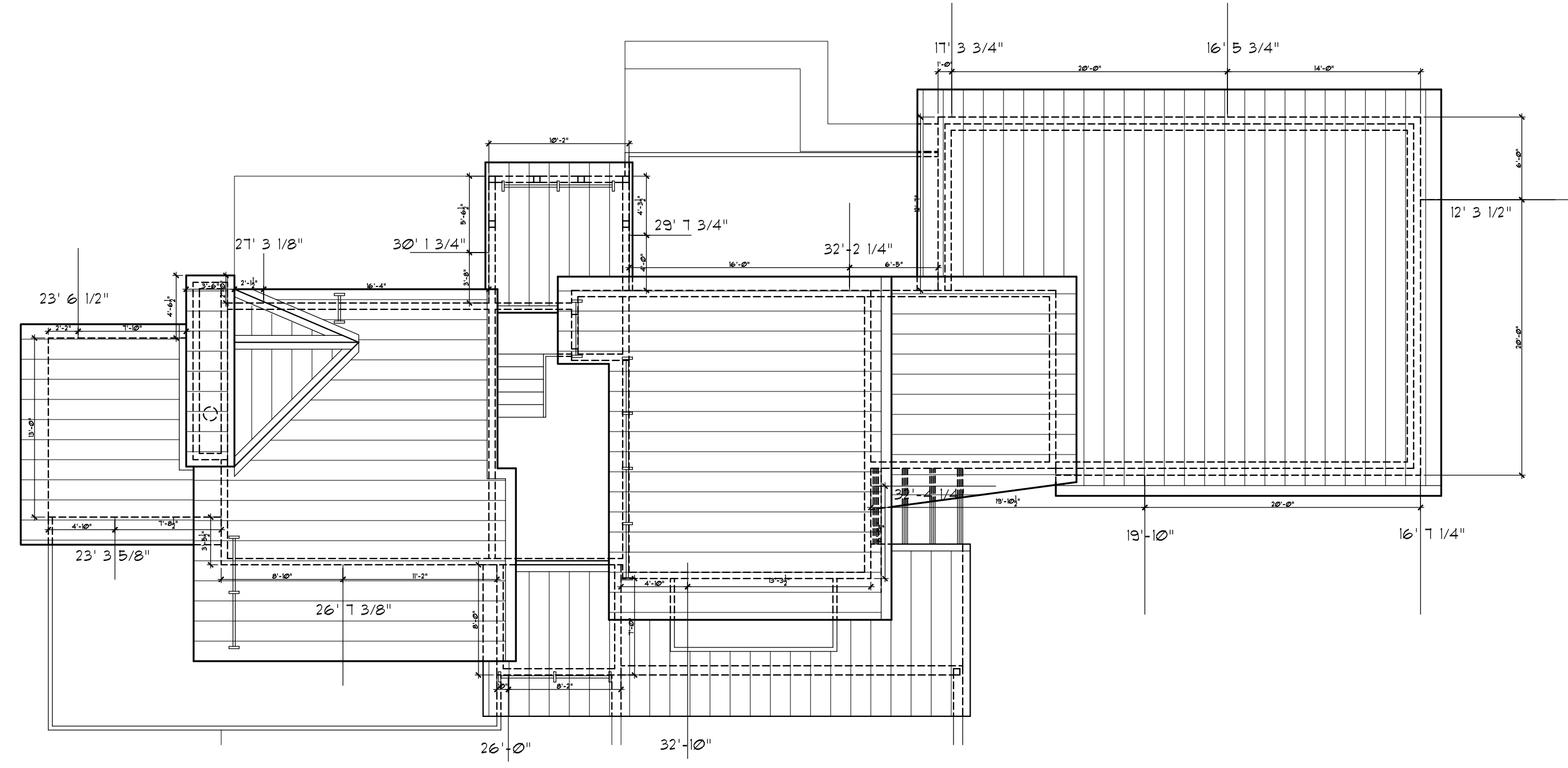



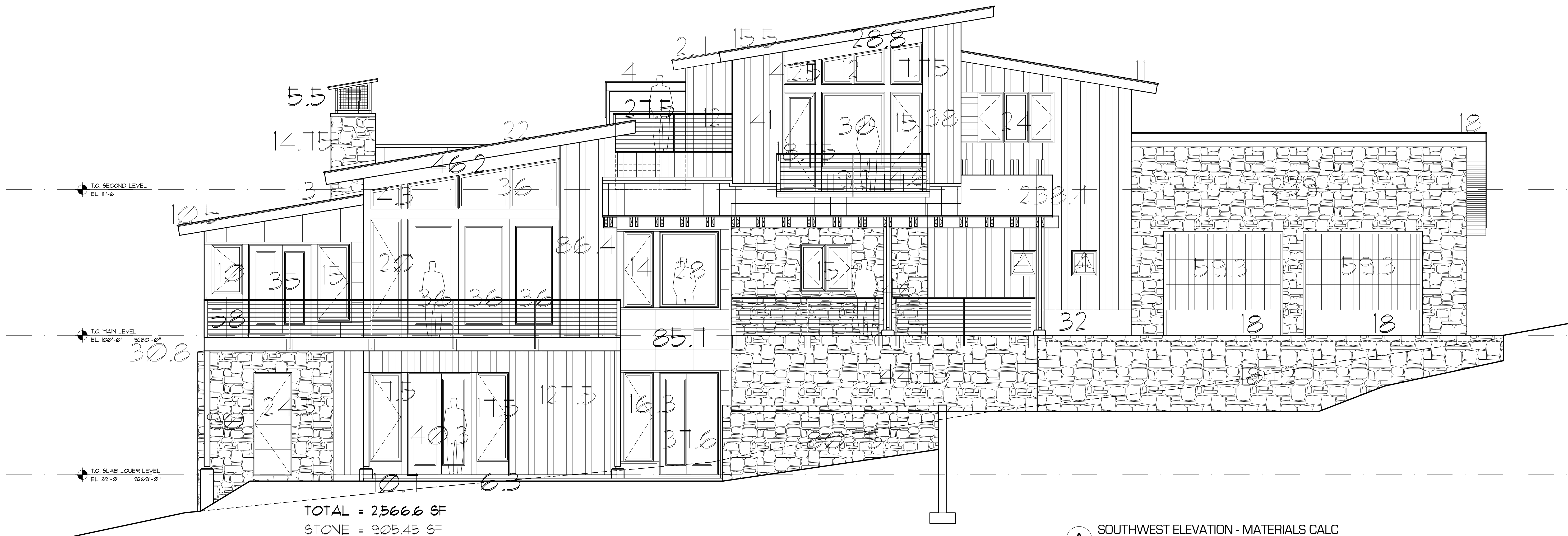

TOTAL = 2,566.6 SF  
 STONE = 905.45 SF  
 WOOD = 1,190.2 SF  
 METAL = 336.7 SF  
 FENESTRATION = 534.25 SF

**A** SOUTHWEST ELEVATION - MATERIALS CALC  
 SCALE 1/4" = 1'-0"

TOTAL = 714.25 SF  
 STONE = 370.5 SF  
 WOOD = 248.05 SF  
 METAL = 31.7 SF  
 FENESTRATION = 58 SF

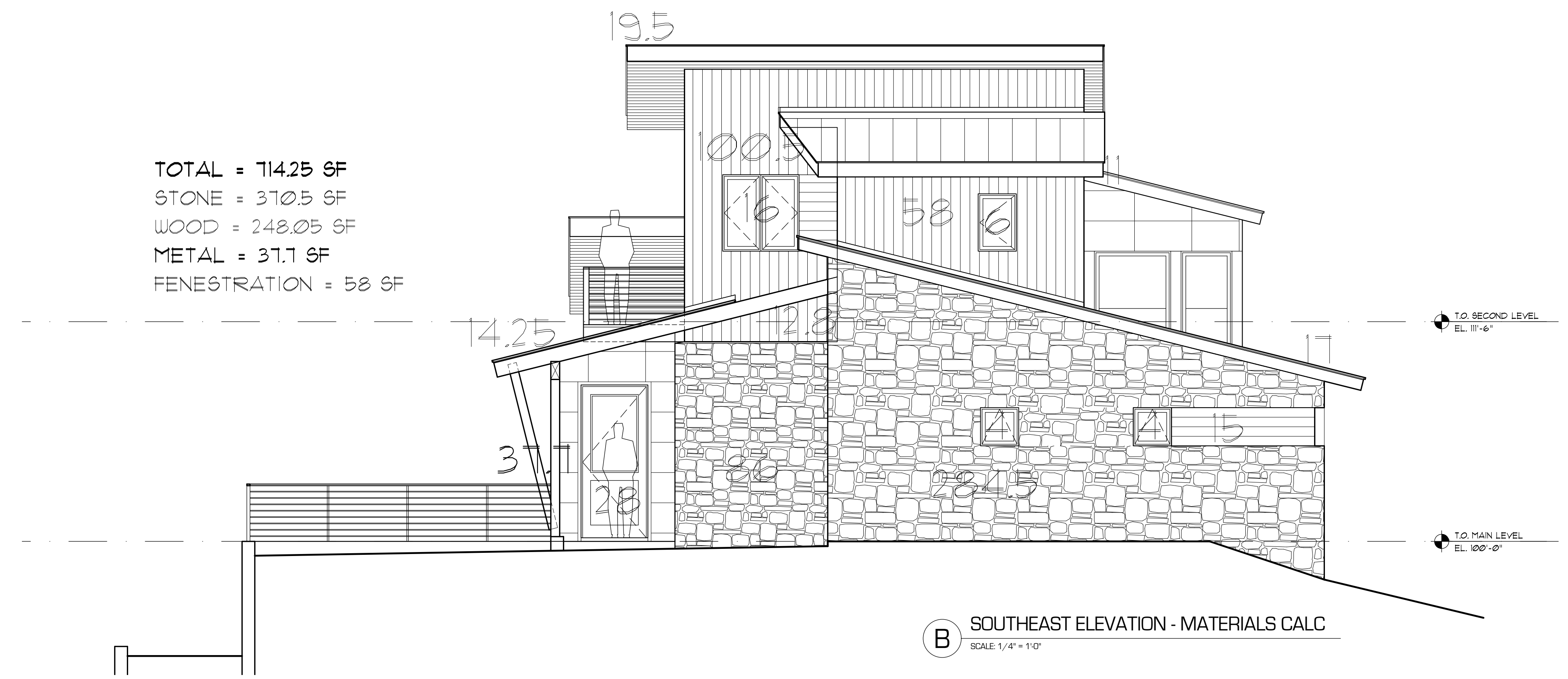

**B** SOUTHEAST ELEVATION - MATERIALS CALC  
 SCALE 1/4" = 1'-0"

FOR REVIEW ONLY NOT FOR CONSTRUCTION

DATE: DECEMBER 22, 2020  
 ISSUED FOR: REVIEW SET

PROJECT: #2008

BACCICH RESIDENCE

COPYRIGHT 2020

REVISIONS:

LOCATION: LOT 729 R-5 91 PENNINGTON PLACE MOUNTAIN VILLAGE SAN MIGUEL COUNTY

SHEET NUMBER: A4-6  
 EXTERIOR ELEVATIONS

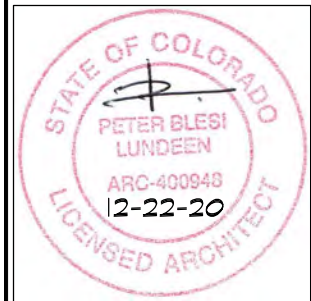

COPYRIGHT 2020



REVISIONS:

BACCICH RESIDENCE

LOT 729 R-5 91 PENNINGTON PLACE MOUNTAIN VILLAGE SAN MIGUEL COUNTY

PROJECT: #2008

DATE: DECEMBER 22, 2020  
ISSUED FOR: REVIEW SET

SHEET NUMBER: A4-7  
EXTERIOR ELEVATIONS

FUSE architecture + interior

220 East Colorado Ave., Suite 218 P.O.Box 3984 Telluride CO 81435. Office: 970-728-0841

FOR REVIEW ONLY NOT FOR CONSTRUCTION

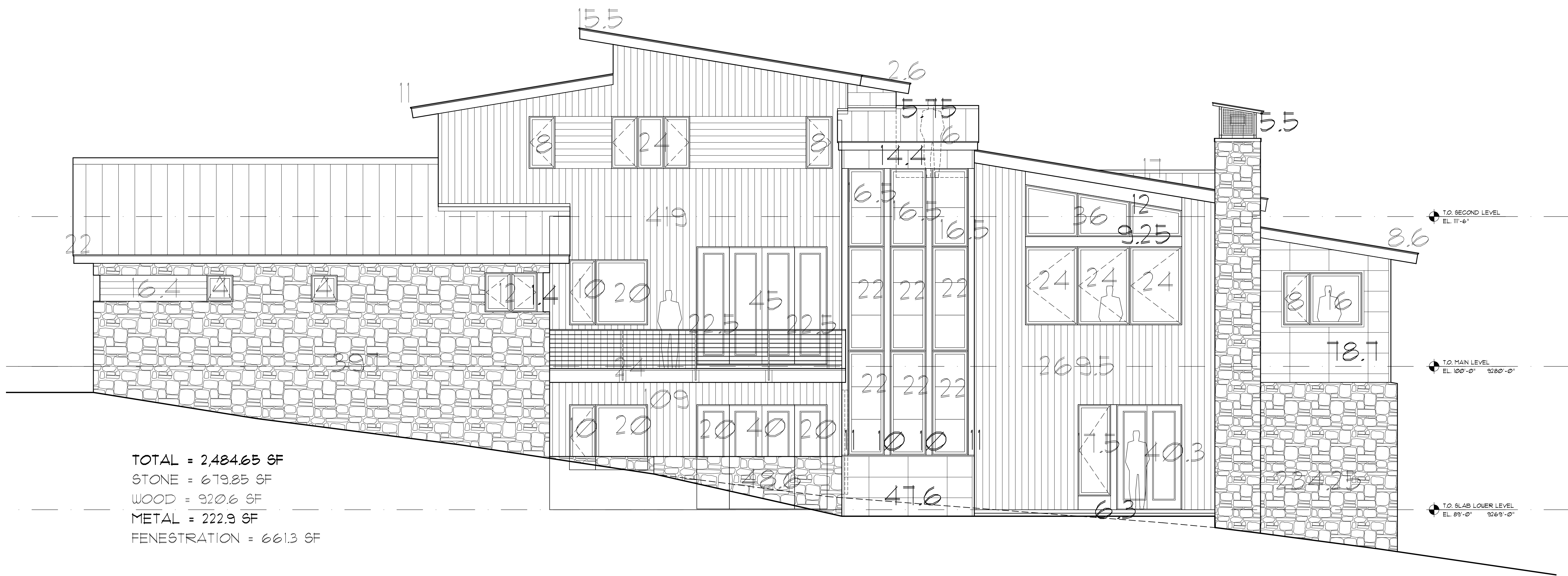

TOTAL = 2,484.65 SF  
 STONE = 679.85 SF  
 WOOD = 920.6 SF  
 METAL = 222.9 SF  
 FENESTRATION = 661.3 SF

A NORTHEAST ELEVATION - MATERIAL CALCS  
 SCALE: 1/4" = 1'-0"

TO SECOND LEVEL  
 EL. 111'-6"

TO MAIN LEVEL  
 EL. 100'-0" 928'-0"

TO SLAB LOWER LEVEL  
 EL. 89'-0" 926'-0"

ELEVATION MATERIALS CALCS	
<b>OVERALL TOTAL = 7,161.4 SF</b>	
STONE = 2,805.5 SF	36.15%
WOOD = 2,210.65 SF	28.48%
METAL = 1,069.95 SF	13.79%
FENESTRATION = 1,615.3 SF	21.58%
<b>S.W. ELEV TOTAL = 2,566.6 SF</b>	
STONE = 905.45 SF	
WOOD = 190.2 SF	
METAL = 336.7 SF	
FENESTRATION = 534.25 SF	
<b>S.E. ELEV TOTAL = 714.25 SF</b>	
STONE = 310.5 SF	
WOOD = 248.05 SF	
METAL = 31.1 SF	
FENESTRATION = 58 SF	
<b>N.E. ELEV TOTAL = 2,484.65 SF</b>	
STONE = 619.85 SF	
WOOD = 920.6 SF	
METAL = 222.9 SF	
FENESTRATION = 661.3 SF	
<b>N.W. ELEV TOTAL = 1,291.35 SF</b>	
STONE = 430.05 SF	
WOOD = 237.9 SF	
METAL = 386.25 SF	
FENESTRATION = 243.15 SF	
<b>N.W. ELEV/SECTION TOTAL = 461.55 SF</b>	
STONE = 419.65 SF	
WOOD = 8.5 SF	
METAL = 1.4 SF	
FENESTRATION = 32.0 SF	
<b>S.E. ELEV/SECTION TOTAL = 237.0 SF</b>	
STONE = 0.0 SF	
WOOD = 5.4 SF	
METAL = 85.0 SF	
FENESTRATION = 146.6 SF	

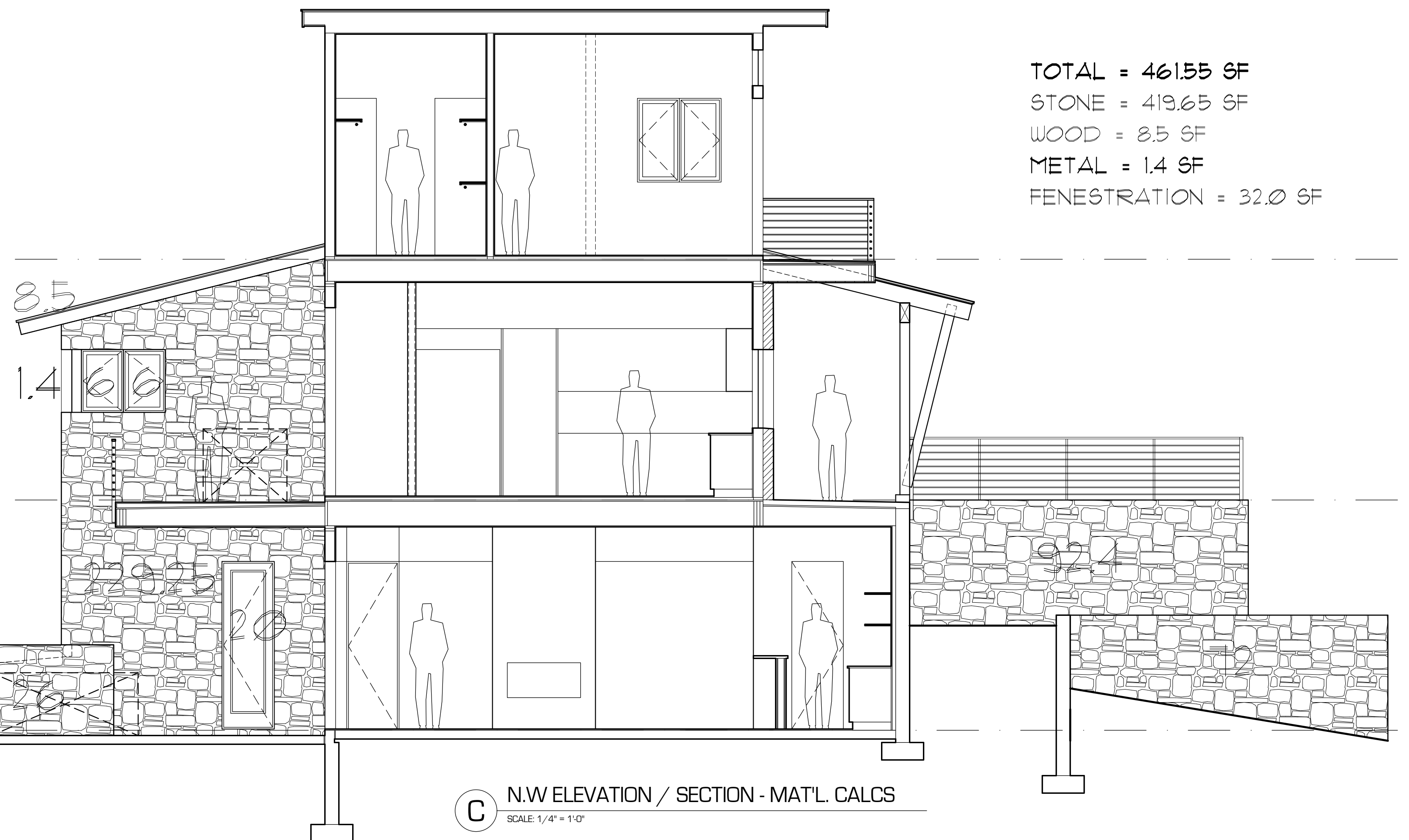
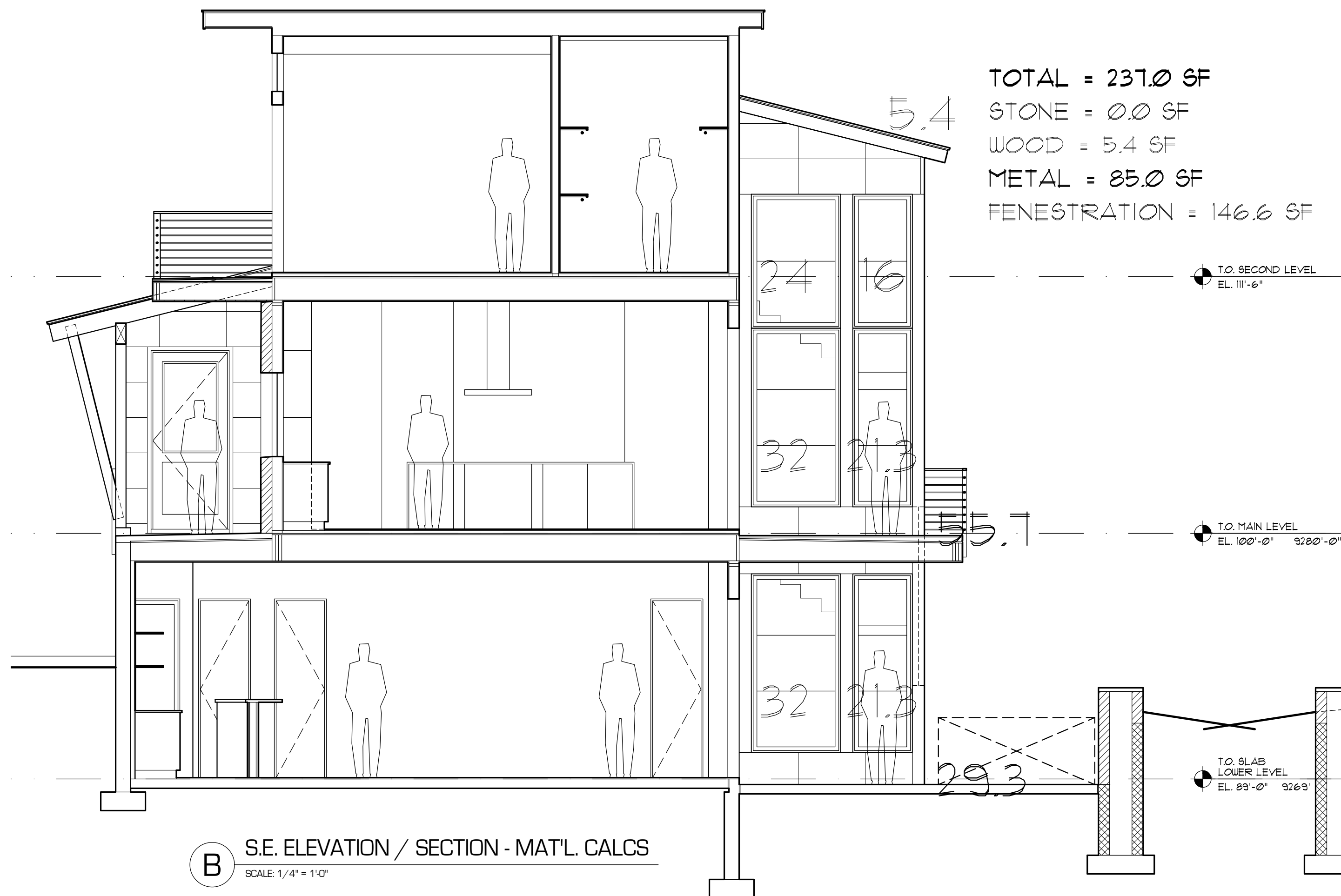

FOR REVIEW ONLY NOT FOR CONSTRUCTION

DATE: DECEMBER 22, 2020  
ISSUED FOR: REVIEW SET

PROJECT: #2008

BACCICH RESIDENCE

REVISIONS:

COPYRIGHT 2020

SHEET NUMBER: A4-8  
EXTERIOR ELEVATIONS

LOCATION: LOT 729 R-5 91 PENNINGTON PLACE MOUNTAIN VILLAGE SAN MIGUEL COUNTY

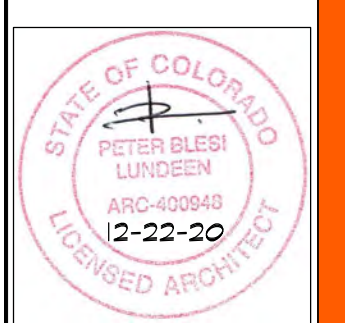

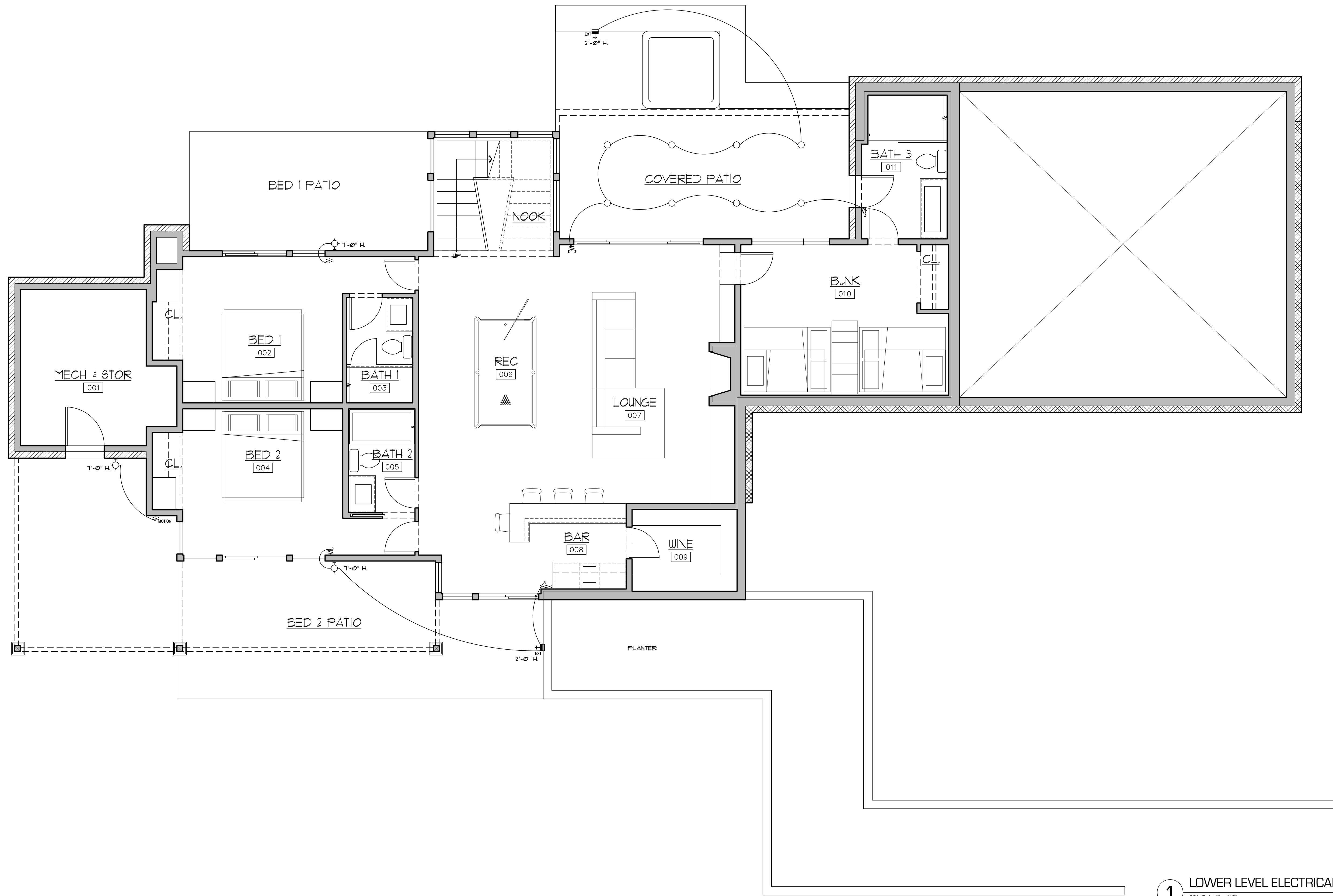

1 LOWER LEVEL ELECTRICAL PLAN  
SCALE: 1/4" = 1'-0"

SYMBOLS LEGEND			
⊕	110V. DUPLEX RECEPTACLE	⬇	RECESSED STEP/PATH LIGHT
⊕ <sub>C</sub>	110V. DUPLEX RECEPTACLE VER. HT. ABOVE COUNTER	⬆	CEILING MOUNTED DIRECTIONAL ART LIGHT
⊕ <sub>GF</sub>	110V. DUPLEX RECEPTACLE GROUND FAULT INTERRUPT	⬆	RECESSED DOWNLIGHT
⊕ <sub>WP</sub>	110V. DUPLEX RECEPTACLE WATERPROOF	⬆	RECESSED DOWNLIGHT - VAPOR PROOF
⊕ <sub>TS</sub>	110V. DUPLEX RECEPTACLE TOP SWITCH CONTROLLED	⬆	FIXTURE - CEILING MOUNTED (EXT. + EXTERIOR SPEC. REQ'D.)
⊕ <sub>220</sub>	220 V. RECEPTACLE	⬆	FIXTURE - CLG. MTD. PENDANT
⊕	110V. DUPLEX RECEPTACLE FLUSH FLOOR MOUNTED	⬆	FIXTURE - WALL MOUNTED (VERIFY HEIGHT - TYPICAL)
⊕	110V. DUPLEX RECEPTACLE CEILING MOUNTED	⬆	WALL WASH / SCONCE
		⬆	UPLIGHTING - WALL MTD.
		⬆	STRIP OR COVE LIGHTING
		⬆	SWING ARM SCONCE
		⬆	BOLLARD LIGHTS
		⬆	FLUORESCENT FIXTURE (VERIFY SIZE)
		⬆	SMOKE DETECTOR
		⬆	EXHAUST FAN - SEE SPEC
		⬆	GARBAGE DISPOSAL
		⬆	DOOR CHIME
		⬆	JETTED BATHTUB PUMP - VERIFY LOCATION
		⬆	ELECTRIC METER
		⬆	MAIN ELECTRICAL PANEL
		⬆	CEILING SPEAKER - RECESSED
		⬆	WALL SPEAKER - RECESSED U.N.O.
		⬆	CEILING FAN
		⬆	TELEPHONE OUTLET
		⬆	TV OUTLET
		⬆	FUTURE-PROOF (2) COAXIAL (VCR/CABLE) OUTLET (2) FIBER OPTIC (2) CAT-5 (PHONE/COMPUTER)
		⬆	SWITCH @ DOOR
		⬆	SINGLE POLE SWITCH
		⬆	THREE WAY SINGLE POLE SWITCH
		⬆	FOUR WAY SINGLE POLE SWITCH
		⬆	MOTION SENSOR SWITCH

- ELECTRICAL NOTES:**
- PRIOR TO ANY WORK BEING PERFORMED UNDER THIS DIVISION CONTRACTOR TO EXAMINE ARCHITECTURAL, STRUCTURAL AND MECHANICAL DRAWINGS AND SPECIFICATIONS AND IF ANY DISCREPANCIES OCCUR BETWEEN THEM AND THE ELECTRICAL DRAWINGS AND SPECIFICATIONS REPORT TO ARCHITECT TO OBTAIN DIRECTION.
  - CONTRACTOR TO COORDINATE ELECTRICAL REQUIREMENTS WITH EQUIPMENT AND APPLIANCE SPECIFICATIONS THROUGHOUT.
  - CONTRACTOR TO COORDINATE OUTLET LOCATIONS AT ALL CMU AND CONCRETE WALLS.
  - ELECTRICAL CONTRACTOR SHALL COORDINATE WALK-THROUGH TO VERIFY LOCATION OF ALL ELECTRICAL SWITCHES, OUTLETS AND FIXTURES WITH OWNER, CONTRACTOR AND ARCHITECT.
  - CONTRACTOR SHALL COORDINATE WALK-THROUGH TO VERIFY LOCATION OF ALL SMOKE DETECTORS WITH OWNER, CONTRACTOR AND ARCHITECT.
  - ELECTRICAL CONTRACTOR TO PROVIDE OUTLETS AT ALL LOCATIONS TO STANDARDS SET FORTH AND WITHIN COMPLETE ACCORDANCE WITH ALL GOVERNING AUTHORITIES HAVING JURISDICTION OVER THE WORK INCLUDING LOCAL UTILITIES AND IN ACCORDANCE WITH THE FIRE UNDERWRITERS REQUIREMENTS. FIELD VERIFY LOCATIONS WITH ARCHITECT PRIOR TO INSTALLATION.
  - CONTRACTOR SHALL COORDINATE WALK-THROUGH TO VERIFY LOCATION OF ALL SMOKE DETECTORS WITH OWNER, CONTRACTOR AND ARCHITECT.
  - TYPICAL SWITCH HEIGHT AT 42" AFF. (UNO.)  
TYPICAL SWITCH HEIGHT AT 36" AFF AT BED LOCATIONS (UNO.)

FOR REVIEW ONLY NOT FOR CONSTRUCTION

DATE: DECEMBER 22, 2020  
ISSUED FOR: REVIEW SET

PROJECT: #2008

PROJECT: BACCICH RESIDENCE

REVISIONS:

SHEET NUMBER: A10-1  
ELECTRICAL PLAN

LOCATION: LOT 729 R-5 91 PENNINGTON PLACE MOUNTAIN VILLAGE SAN MIGUEL COUNTY

COPYRIGHT 2020

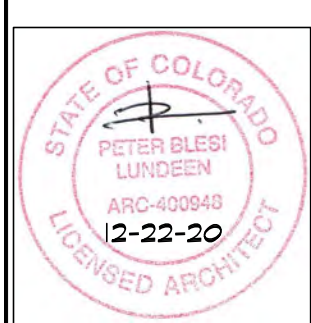

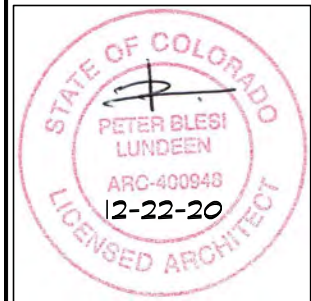

REVISIONS:

BACCICH RESIDENCE

PROJECT: #2008

DATE: DECEMBER 22, 2020  
ISSUED FOR: REVIEW SET

LOCATION: LOT 729 R-5 91 PENNINGTON PLACE MOUNTAIN VILLAGE SAN MIGUEL COUNTY

SHEET NUMBER: A10-2  
ELECTRICAL PLAN

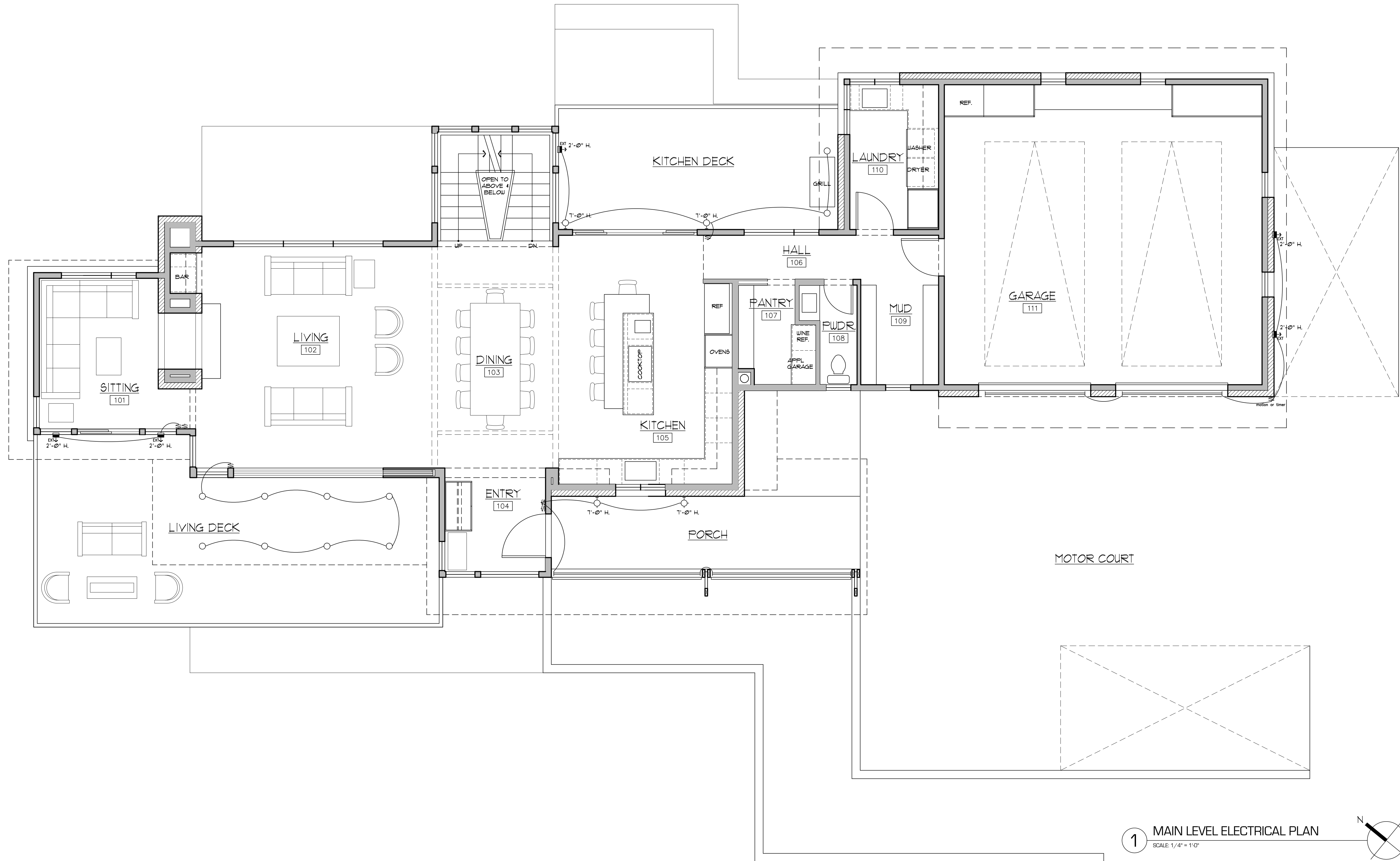

1 MAIN LEVEL ELECTRICAL PLAN  
SCALE: 1/4" = 1'-0"

SYMBOLS LEGEND			
⊕	110V. DUPLEX RECEPTACLE	▬	RECESSED STEP/PATH LIGHT
⊕ <sub>C</sub>	110V. DUPLEX RECEPTACLE VER. HT. ABOVE COUNTER	⊕	CEILING MOUNTED DIRECTIONAL ART LIGHT
⊕ <sub>GI</sub>	110V. DUPLEX RECEPTACLE GROUND FAULT INTERRUPT	○	RECESSED DOWNLIGHT
⊕ <sub>WP</sub>	110V. DUPLEX RECEPTACLE WATERPROOF	○ <sub>VP</sub>	RECESSED DOWNLIGHT - VAPOR PROOF
⊕ <sub>TS</sub>	110V. DUPLEX RECEPTACLE TOP SWITCH CONTROLLED	⊕	FIXTURE - CEILING MOUNTED (EXT. + EXTERIOR SPEC. REQ'D.)
⊕ <sub>220</sub>	220 V. RECEPTACLE	⊕	FIXTURE - CLG. MTD. PENDANT
○	110V. DUPLEX RECEPTACLE FLUSH FLOOR MOUNTED	⊕	FIXTURE - WALL MOUNTED (VERIFY HEIGHT - TYPICAL)
⊕	110V. DUPLEX RECEPTACLE CEILING MOUNTED	⊕	WALL WASH / SCONCE
		●	UPLIGHTING - WALL MTD.
		⊕	STRIP OR COVE LIGHTING
		⊕	SWING ARM SCONCE
		●	BOLLARD LIGHTS
		▭	FLUORESCENT FIXTURE (VERIFY SIZE)
⊕	SMOKE DETECTOR	⊕	SWITCH @ DOOR
⊕ <sub>EF</sub>	EXHAUST FAN - SEE SPEC	⊕	SINGLE POLE SWITCH
⊕ <sub>GD</sub>	GARBAGE DISPOSAL	⊕	THREE WAY SINGLE POLE SWITCH
⊕	DOOR CHIME	⊕	FOUR WAY SINGLE POLE SWITCH
⊕	JETTED BATHTUB PUMP - VERIFY LOCATION	⊕	MOTION SENSOR SWITCH
⊕	ELECTRIC METER		
⊕	MAIN ELECTRICAL PANEL		
⊕	CEILING SPEAKER - RECESSED		
⊕	WALL SPEAKER - RECESSED U.N.O.		
		⊕	CEILING FAN
		⊕	TELEPHONE OUTLET
		⊕	TV OUTLET
		⊕	FUTURE-PROOF (2) COAXIAL (VCR/CABLE) OUTLET (2) FIBER OPTIC (2) CAT-5 (PHONE/COMPUTER)

- ELECTRICAL NOTES:**
- PRIOR TO ANY WORK BEING PERFORMED UNDER THIS DIVISION CONTRACTOR TO EXAMINE ARCHITECTURAL, STRUCTURAL AND MECHANICAL DRAWINGS AND SPECIFICATIONS AND IF ANY DISCREPANCIES OCCUR BETWEEN THEM AND THE ELECTRICAL DRAWINGS AND SPECIFICATIONS REPORT TO ARCHITECT TO OBTAIN DIRECTION.
  - CONTRACTOR TO COORDINATE ELECTRICAL REQUIREMENTS WITH EQUIPMENT AND APPLIANCE SPECIFICATIONS THROUGHOUT.
  - CONTRACTOR TO COORDINATE OUTLET LOCATIONS AT ALL CMU AND CONCRETE WALLS.
  - ELECTRICAL CONTRACTOR SHALL COORDINATE WALK-THROUGH TO VERIFY LOCATION OF ALL ELECTRICAL SWITCHES, OUTLETS AND FIXTURES WITH OWNER, CONTRACTOR AND ARCHITECT.
  - CONTRACTOR SHALL COORDINATE WALK-THROUGH TO VERIFY LOCATION OF ALL SMOKE DETECTORS WITH OWNER, CONTRACTOR AND ARCHITECT.
  - ELECTRICAL CONTRACTOR TO PROVIDE OUTLETS AT ALL LOCATIONS TO STANDARDS SET FORTH AND WITHIN COMPLETE ACCORDANCE WITH ALL GOVERNING AUTHORITIES HAVING JURISDICTION OVER THE WORK INCLUDING LOCAL UTILITIES AND IN ACCORDANCE WITH THE FIRE UNDERWRITERS REQUIREMENTS. FIELD VERIFY LOCATIONS WITH ARCHITECT PRIOR TO INSTALLATION.
  - TYPICAL SWITCH HEIGHT AT 42" AFF. (UNO.)  
TYPICAL SWITCH HEIGHT AT 36" AFF AT BED LOCATIONS (UNO.)

FOR REVIEW ONLY NOT FOR CONSTRUCTION

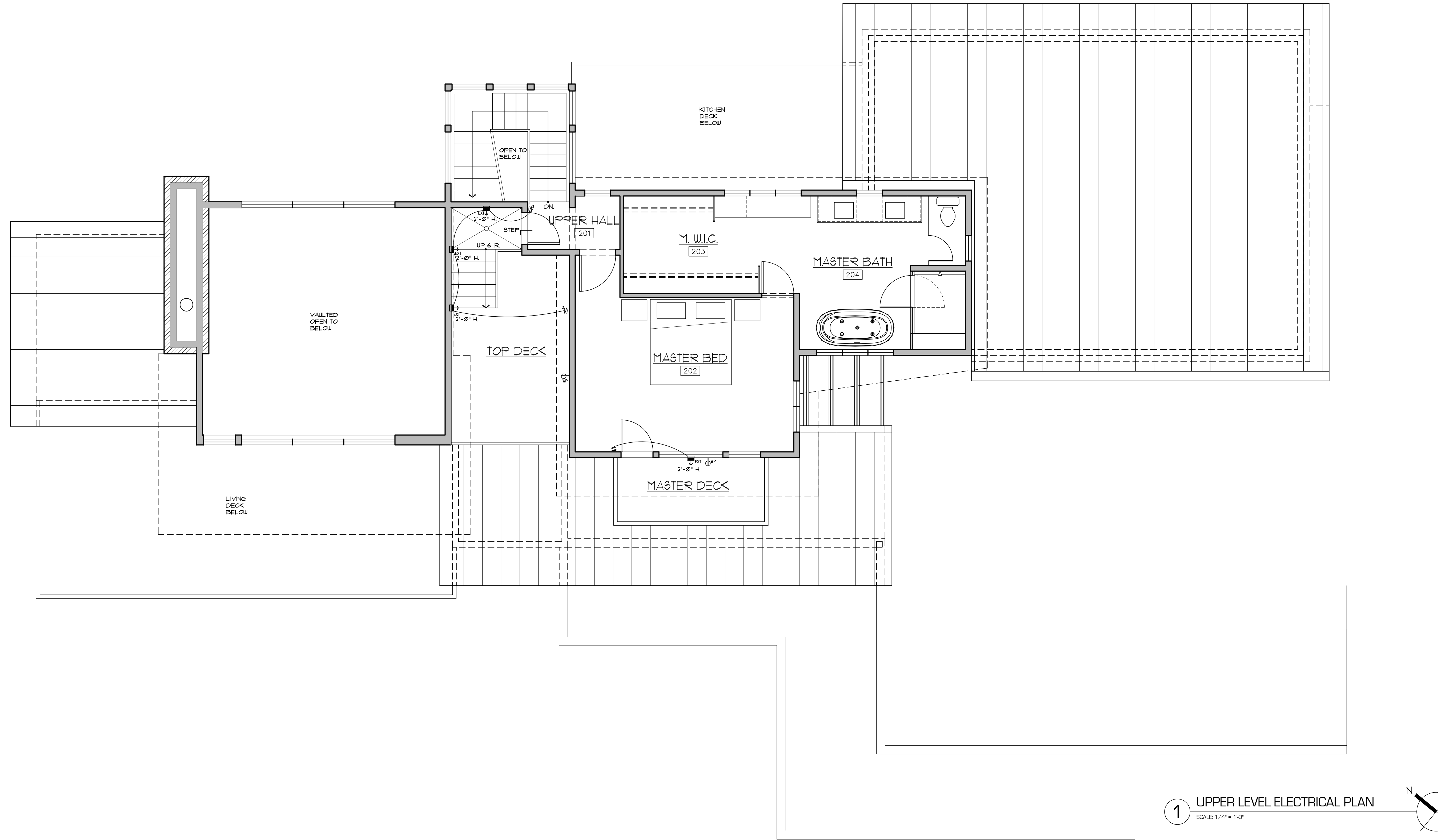

**1** UPPER LEVEL ELECTRICAL PLAN  
SCALE: 1/4" = 1'-0"

SYMBOLS LEGEND			
⊕	110V. DUPLEX RECEPTACLE	⬇	RECESSED STEP/PATH LIGHT
⊕ <sub>C</sub>	110V. DUPLEX RECEPTACLE VER. HT. ABOVE COUNTER	☉	CEILING MOUNTED DIRECTIONAL ART LIGHT
⊕ <sub>GI</sub>	110V. DUPLEX RECEPTACLE GROUND FAULT INTERRUPT	○	RECESSED DOWNLIGHT
⊕ <sub>WP</sub>	110V. DUPLEX RECEPTACLE WATERPROOF	○ <sub>VP</sub>	RECESSED DOWNLIGHT - VAPOR PROOF
⊕ <sub>TS</sub>	110V. DUPLEX RECEPTACLE TOP SWITCH CONTROLLED	⊕	FIXTURE - CEILING MOUNTED (EXT. - EXTERIOR SPEC. REQ'D.)
⊕ <sub>220</sub>	220 V. RECEPTACLE	⊕	FIXTURE - CLG. MTD. PENDANT
○	110V. DUPLEX RECEPTACLE FLUSH FLOOR MOUNTED	⊕	FIXTURE - WALL MOUNTED (VERIFY HEIGHT - TYPICAL)
⊕	110V. DUPLEX RECEPTACLE CEILING MOUNTED	⊕	WALL WASH / SCIENCE
		●	UPLIGHTING - WALL MTD.
		⬆	STRIP OR COVE LIGHTING
		⬆	SWING ARM SCIENCE
		●	BOLLARD LIGHTS
		▭	FLUORESCENT FIXTURE (VERIFY SIZE)
		⊕	SMOKE DETECTOR
		⊕	EXHAUST FAN - SEE SPEC
		⊕	GARBAGE DISPOSAL
		⊕	DOOR CHIME
		⊕	JETTED BATHTUB PUMP - VERIFY LOCATION
		⊕	ELECTRIC METER
		⊕	MAIN ELECTRICAL PANEL
		⊕	CEILING SPEAKER - RECESSED
		⊕	WALL SPEAKER - RECESSED U.N.O.
		⊕	CEILING FAN
		⊕	TELEPHONE OUTLET
		⊕	TV OUTLET
		⊕	FUTURE-PROOF (2) COAXIAL (VCR/CABLE) OUTLET (2) FIBER OPTIC (2) CAT-5 (PHONE/COMPUTER)
		⊕	SWITCH @ DOOR
		⊕	SINGLE POLE SWITCH
		⊕	THREE WAY SINGLE POLE SWITCH
		⊕	FOUR WAY SINGLE POLE SWITCH
		⊕	MOTION SENSOR SWITCH

- ELECTRICAL NOTES:**
- PRIOR TO ANY WORK BEING PERFORMED UNDER THIS DIVISION CONTRACTOR TO EXAMINE ARCHITECTURAL, STRUCTURAL AND MECHANICAL DRAWINGS AND SPECIFICATIONS AND IF ANY DISCREPANCIES OCCUR BETWEEN THEM AND THE ELECTRICAL DRAWINGS AND SPECIFICATIONS REPORT TO ARCHITECT TO OBTAIN DIRECTION.
  - CONTRACTOR TO COORDINATE ELECTRICAL REQUIREMENTS WITH EQUIPMENT AND APPLIANCE SPECIFICATIONS THROUGHOUT.
  - CONTRACTOR TO COORDINATE OUTLET LOCATIONS AT ALL CMU AND CONCRETE WALLS.
  - ELECTRICAL CONTRACTOR SHALL COORDINATE WALK-THROUGH TO VERIFY LOCATION OF ALL ELECTRICAL SWITCHES, OUTLETS AND FIXTURES WITH OWNER, CONTRACTOR AND ARCHITECT.
  - CONTRACTOR SHALL COORDINATE WALK-THROUGH TO VERIFY LOCATION OF ALL SMOKE DETECTORS WITH OWNER, CONTRACTOR AND ARCHITECT.
  - ELECTRICAL CONTRACTOR TO PROVIDE OUTLETS AT ALL LOCATIONS TO STANDARDS SET FORTH AND WITHIN COMPLETE ACCORDANCE WITH ALL GOVERNING AUTHORITIES HAVING JURISDICTION OVER THE WORK INCLUDING LOCAL UTILITIES AND IN ACCORDANCE WITH THE FIRE UNDERWRITERS REQUIREMENTS. FIELD VERIFY LOCATIONS WITH ARCHITECT PRIOR TO INSTALLATION.
  - CONTRACTOR SHALL COORDINATE WALK-THROUGH TO VERIFY LOCATION OF ALL SMOKE DETECTORS WITH OWNER, CONTRACTOR AND ARCHITECT.
  - TYPICAL SWITCH HEIGHT AT 42" AFF. (UNO.) TYPICAL SWITCH HEIGHT AT 36" AFF AT BED LOCATIONS (UNO.)

FOR REVIEW ONLY NOT FOR CONSTRUCTION

DATE: DECEMBER 22, 2020  
ISSUED FOR: REVIEW SET

PROJECT: #2008  
LOCATION: LOT 729 R-5 91 PENNINGTON PLACE MOUNTAIN VILLAGE SAN MIGUEL COUNTY

REVISIONS:

SHEET NUMBER: A10-3  
ELECTRICAL PLAN

COPYRIGHT 2020

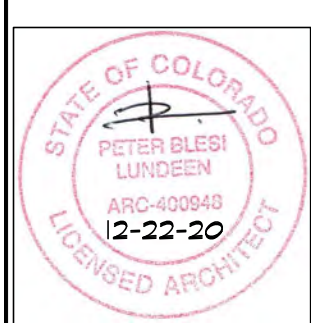

## Exhibit B

Lot 729 R-5 / 91 Pennington PL.

Henry Haizlip [Henry@grinderhaizlip.com](mailto:Henry@grinderhaizlip.com)

I have reviewed the documents at great length and I am most happy with the design of the house. I cannot support the requested variation for parking in the general easement. I have explained to the Architect and owners, in person, that our neighborhood is on the radar for more development. The remaining lots present problems in size and shape and I cannot support a variance that sets a precedent for other zoning requests which may negatively affect our current neighbors sight lines and views.

Sincerely, Henry and Sarah Haizlip

100 Pennington Pl. #5

Cell: 901 832-0267



AGENDA ITEM 7  
**PLANNING & DEVELOPMENT SERVICE**  
**PLANNING DIVISION**  
455 Mountain Village Blvd.  
Mountain Village, CO 81435  
(970) 728-1392

**TO:** Mountain Village Design Review Board

**FROM:** John Miller, Senior Planner

**FOR:** Design Review Board Public Hearing; February 4, 2021

**DATE:** January 23, 2021

**RE:** Staff Memo – Initial Architecture and Site Review (IASR) Lot 161D-1 Unit 17

## APPLICATION OVERVIEW:

### **PROJECT GEOGRAPHY**

**Legal Description:** UNIT 17 THE RIDGE AT TELLURIDE A PLANNED COMMUNITY LOT 161A4 ACC TO PLAT REC 04 05 2004 BK 1 PG 3262 3265 AND ACC TO 6TH SUPPLEMENTAL AND AMENDED PLANNED COMMUNITY PLAT PHASES 1 THRU 7 REC 07 02 2010 PLAT BK 1 PG 4349 4353 AND 6TH SUPPLEMENT & AMENDMENT TO DECS AT 413135 A 5.55 PER INT IN UNIT 4 LOT 161A 1R BLDG LOT 161 D1 OPEN SPACE TRACTS ROS 1A 2C 4B 5A 6A 7A LOT 161A 4 OPEN SPACE TRACTS ROS 1B 2B 3A 4A AND LOT 161A R3 OPEN SPACE TRACT ROS 5B COMMON ELEMENTS

**Address:** 6 Tunnel Lane  
**Applicant/Agent:** Chris Hawkins, Alpine Planning  
**Owner:** Telluride Longview LLC  
**Zoning:** Multi-Family  
**Existing Use:** Vacant Lot  
**Proposed Use:** Detached Condominium  
**Lot Size:** 7,500 square feet

#### **Adjacent Land Uses:**

- **North:** Multi-Family
- **South:** Open Space
- **East:** Multi-Family
- **West:** Multi-Family

### **ATTACHMENTS**

Exhibit A: Architectural Plan Set  
Exhibit B: Staff/Referral Comments



*Figure 1: Vicinity Map*



**Case Summary:** Chris Hawkins of Alpine Planning (Applicant), on the behalf of Telluride Longview LLC (Owner) is requesting Design Review Board (DRB) approval of an Initial Architectural and Site Review (IASR) Application for a new single-family detached condominium located at Lot 161D-1, Unit 17, 6 Tunnel Lane. The Lot is 7,500 square feet and is zoned Multi-Family. The proposal includes a detached condo with the approximate gross square footage of 6,720 square feet. Because of the home’s location near the top of Coonskin Ridge, additional development regulations must be addressed in addition to the general Design Review Standards – specifically, CDC Section 17.5.16: Ridgeline Lots. The applicant has provided all the required materials for the IASR for the proposed home. It should be noted that this application does include an unfinished space to later be converted into a mother-in-law suite. This is permitted by the CDC for detached condominiums.

County and Town Settlement Agreement

In 1999 the Town and County entered into a settlement agreement that addressed a number of county issues and controls including the operations of the gondola, the Ridgeline Covenant, the final Mountain Village development plan, wetland regulations, and deed restricted housing. This unit is subject to the Ridgeline Covenant, the regulations associated are noted above as outlined in the CDC. Pursuant to the settlement agreement and the Ridgeline Covenant, the Town of Mountain Village sends development application referrals to San Miguel County and the Town of Telluride should the properties be referenced in the Ridgeline Covenant. There is also an associated story pole requirement again required both by the CDC and the Ridgeline Covenant. What is within the DRB’s purview are the provisions outlined in the CDC. The Town does not enforce the provisions of the Settlement Agreement although we adhere to the courtesy notice provisions as outlined in the settlement agreement.

Story Pole Requirement

Due to the location of the home as it relates to the Ridgeline Covenant, and the geographical ridge elevation, the applicant has requested the Community Development Director waive the story pole requirement. This request is at the Director’s discretion per the CDC. This request is also consistent with the Lot 161D-1 Unit 15’s waiver approval which occurred in 2016.

**Applicable CDC Requirement Analysis:** The applicable requirements cited may not be exhaustive or all-inclusive. The applicant is required to follow all requirements even if an applicable section of the CDC is not cited. ***Please note that Staff comments will be indicated by Italicized Text.***

*Table 1*

<u>CDC Provision</u>	<u>Requirement</u>	<u>Proposed</u>
<b>Maximum Building Height</b>	45’ (ridge allowance)	42’ – 4 ½”
<b>Maximum Average Height</b>	30’ (ridge allowance)	28’ – 9 “
<b>Maximum Lot Coverage</b>	Not applicable to Ridge	
<b>General Easement Setbacks</b>	No GE	
<b>Roof Pitch</b>		
Primary		10:12
Secondary		Multiple
<b>Exterior Material**</b>		
Stone	35% minimum	37.5%
Windows/Doors	40% maximum	26.5%
<b>Parking</b>	1	1*

\*Additional information has been provided below regarding parking at the Ridge.

## **Chapter 17.3: ZONING AND LAND USE REGULATIONS**

### **17.3.12: Building Height Limits**

Sections 17.3.11 and 17.3.12 of the CDC provide the methods for measuring Building Height and Average Building Height, along with providing the height allowances for specific types of buildings based on their architectural form. The proposed design incorporates mostly Gabled roof forms with one lower shed roof projecting outward. Because of development agreements memorialized in the CDC, the Unit 17 is classified as a ridge lot, and with that it is granted a different height allowance than other detached condominiums in the Mountain Village. The unit is subject in this case to a 45-foot height limit from finished grade.

*Staff: As part of this application, a Maximum Building Height and Average Building Height calculation has been provided on pages A3.1 – A3.3 and shown above in Table 1. Portions of Unit 17 are over 30% slope and although these areas will be somewhat disturbed during development, it appears that the design of the home attempts to minimize these disturbances through a subdued design that incorporates the home into the hillside. With a Maximum Height of approximately 42 feet and an Max Average Height of almost 30 feet, any future approval should condition that a height survey be required prior to the issuance of a framing inspection to determine the heights comply with any DRB approved plan and the development agreement for Coonskin Ridge.*

### **17.3.14: General Easement Setbacks**

Lot 161D-1, Unit 17 is not burdened by any General Easements or Setbacks. The development documents specify that each unit on Lot 161D-1 is permitted to utilize the full 7,500 square feet allocated.

## **Chapter 17.5: DESIGN REGULATIONS**

### **17.5.4: Town Design Theme**

The Town of Mountain Village has established design themes aimed at creating a strong image and sense of place for the community. Due to the fragile high alpine environment, architecture and landscaping shall be respectful and responsive to the tradition of alpine design – reflecting elements of alpine regions while blending influences that visually tie the town to mountain buildings. The town recognizes that architecture will continue to evolve and create a regionally unique mountain vernacular, but these evolutions must continue to embrace nature and traditional style in a way that respects the design context of the neighborhoods surrounding the site.

*Staff: The massing and form of the proposed home at Unit 17 is very traditional as it relates to recent home designs in the Mountain Village. The offset gabled roof form appears to be augmented nicely through the lower long shed roof. The materials – particularly the dry stack gold stone veneer and Corten metal siding tie the home visually with other homes on the ridge and throughout the Mountain Village. Even with the traditional form, staff believes this home to be categorized as a Mountain Modern design given the strong lines and modern materials that have been incorporated.*

*The home is sized at approximately 6,700 gross square feet, which is in line with other home sizes along the ridge. Even with the large size, the home does feel like it has been built into the hillside in a way that reduces its overall mass, particularly as seen from the top of coonskin ridge looking downhill. The DRB may want to minimize or otherwise break up some of the glazing along the south elevation of the home (shown on page A3.2). This elevation will be best seen from the Mountain Village and it may create visual impacts through interior lighting penetrating the glazing.*

*It appears based on the applicant's submittal that the material palette for the project blends well with both the surrounding community, as well as the overall modern mountain vernacular. Staff is curious about the proposed equitone cementitious panels and as such is requesting additional information related to this product and its suitability for use at high elevation sites. The materials are discussed below in more detail as it relates to the ridgeline lot requirements of Section 17.5.16.*

#### **17.5.5: Building Siting Design**

The CDC requires that any proposed development blend into the existing landforms and vegetation.

*Staff: As briefly mentioned above, these lots essentially function as footprint lots and allow for full development of the allocated 7,500 square feet. With that, the location of the homes building envelope is tied to the subdivision documents and the location of the specific units within Lot 161D-1. It does appear that the home has attempted some visual subordination by incorporating the design of the home into the hillside. This appears to result in a less proud home as seen from the Mountain Village. Due to the steep slopes, vegetation, and location – it will be difficult to blend all future development of the homesites into the existing landforms entirely. With that being said, staff believes this project to be accomplishing this standard.*

#### **17.5.6: Building Design**

*Staff: The CDC requires that building form and exterior wall forms portray a mass that is thick and strong with a heavy grounded foundation. Although the applicant is meeting the material requirements for stone and fenestration, certain elevations appear to feel more grounded than others. In particular, stone on the north elevation is limited – which to staff feels problematic given that the home will be best seen from this elevation as pedestrians and skiers exit the gondola during winter and summer months. It may be preferable to shift the stone slightly or increase the stone percentage in order to provide additional grounding along this northern elevation. Because of the elevation of the site, snow depth could be problematic and there are concerns related to the long-term suitability of the Corten Metal and Cementitious panels if they are not protected from snow and water. Staff recommends that the applicant provide additional documentation related to these materials. Staff is also recommending slightly breaking up the glazing amounts on the south elevation – in particular the area shown below.*



*The home's exterior palette contrasts and blends well between the gold stone, the rusted Corten Metal and the darker grey-black elements of the home. It appears that the garage door is also the same cementitious panel material provided in the material list. The CDC allows for black metal standing seam roofing materials and this appears to meet that requirement.*

*The applicant has not indicated areas of snowmelt, but the CDC allows for 1000 square feet of snowmelt without penalty. Staff recommends identifying and including those areas in a final design review application.*

#### **17.5.7: Grading and Drainage Design**

*Staff: The applicant has provided a conceptual grading and drainage plan as it relates to access, and grading required for areas surrounding the home. Generally speaking, grading is minimized from the east of the home and largely focuses on areas downhill of the home within the area identified as the "landscape buffer area". Prior to the final review, a finished slope calculation shall be provided for all areas of grading to determine appropriate revegetation and stormwater requirements. Additionally, the engineer shall revise page A2.5 to demonstrate compliance with the CDC as it relates to driveway standards and retaining wall heights.*

#### **17.5.8: Parking Regulations**

*Pursuant to Resolution No. 2003-0610-10 and the Lot 161CR settlement agreement the parking requirement for this property is one parking space to be satisfied either by a parking reservation agreement at Lot 161CR when the parking garage is finally developed or a parking payment in lieu to the Town of Mountain Village. Unit 17 executed a Reservation and Escrow Agreement and deposited the corresponding \$60,000 deposit for a deed parking space on June 6, 2019, per the parking settlement agreement. As such, Unit 17 currently parks on the surface of Lot 161C-R and will have a deeded parking space when covered parking is completed." (Sic)*

#### **17.5.9: Landscaping Regulations**

*The applicant has provided a preliminary landscaping plan showing the general intent of the future landscaping. Staff is requesting that prior to final review, the applicant modify this conceptual plan to include specific species and sizes within the planting schedule along with planting notes, revegetation notes, and other general requirements. Due to the home's location and visibility, staff is requesting that the DRB waive the requirements of the Fire Mitigation Section of the CDC.*

#### **17.5.11: Utilities**

*Staff: All utilities are currently located within proximity to the home. The applicant shall work with the Public Works Director before the final review to verify the specific locations of the connections for the home. The plan set shows the proposed connections and the locations of the proposed utilities based on field research.*

#### **17.5.12: Lighting Regulations**

*Staff: The applicant has not provided a lighting plan at this time. Prior to final review, the applicant shall review the plan set to include a full lighting plan with locations of lamps, cut sheets, as well as a photometric study of the site. It will be important to provide very subdued lighting given the visibility of the home from the Mountain Village Core.*

### **17.5.13: Sign Regulations**

*Staff: The applicant has not provided details on the address monument / location. Prior to final review, the applicant shall provide a full address monument design to include location and method of illumination.*

### **17.5.16: Ridgeline Lots**

*The CDC identifies Lot 161D-1 as a part of the Ridge Area and as such provides additional design restrictions. As previously described, the intent of these standards is to memorialize the restrictions in the development agreement. These provisions attempt to require the home to maintain visual subordination to the natural landscape along the ridge.*

*In order to accomplish this, the code requires the following:*

1. *All improvements are subject to a ridgeline covenant with San Miguel County as recorded at reception number 329093. The Town does not enforce the ridgeline covenant, with enforcement solely administered by San Miguel County.*

*Staff: The improvements appear to be aligned with the ridgeline covenant as discussed above within this memo. The Town of Mountain Village does not enforce this covenant but provided this application and all materials to both San Miguel County and the Town of Telluride in order for those agencies to provide comment on the proposed application.*

2. *The building height on Lot 161A-1R shall not exceed 35 feet (35') along the ridgeline of such building.*

*Staff: Not applicable. Subject unit is within Lot 161D-1.*

3. *Building height on other ridge area lots shall not exceed the lesser of:
  - a. *The height of forty-five feet (45'); or*
  - b. *The maximum height allowed to the view plane limitation set forth in section 4 below.**

*Staff: The applicant is meeting these criteria with the propose design. Because this lot is not within an identified view plane, it is limited by a height of 45 feet.*

4. *Except for the existing building on Lot 161A-1R and gondola facilities, the development of ridgeline area lots shall be designed to ensure that no lighting or any part of any building or structure extends into the view plane as shown on the Coonskin View Plane drawing recorded at reception number 328113.*

*Staff: Not applicable. Subject unit is not located within any view plane identified on the Coonskin View Plane.*

5. *New development in the ridgeline area, excluding the existing building on Lot 161A-1R and gondola facilities, shall require (a) the erection of a story pole to reflect the maximum height of the proposed development where such development will extend closest to the view plane as described in section 4 above; and (b) the installation of a light to illuminate the story pole where off-site light would be visible from the highest window. The applicant for development shall provide written notice of the story pole erection to San Miguel County and the Town of Telluride.*

*Staff: The Town of Mountain Village has waived this request due to the location of the site in relation to the Coonskin View Plane survey and the geographical ridge. SMC as a courtesy has agreed to this waiver request. The applicant has provided the following within their attached narrative: "Unit 17 is carved out of Lot 161D-1 and is located below the currently under construction home on Unit 15. There is no way the home will be visible from either Telluride or the Valley Floor since it is well below the geographic ridge. The highest roof elevation is approximately 10486 while the geographic ridge is located around approximately 10560. As a reference point, the roof on Unit 15 that is currently under construction to the north of and above Unit 17 has its highest roof ridge elevation of 10531.6' and you cannot see that from Telluride or the Valley Floor."*

- 6. To the extent practical, no exterior lights shall be installed on the east side of buildings. Any required exterior lighting shall be shielded, recessed, or reflected so that no lighting is oriented towards the east side of the building.*

*Staff: This item has been addressed above within the Lighting Standards.*

- 7. No solid fuel burning device shall be allowed in the building on Lot 161A-1R.*

*Staff: All fireplaces at the home are required to be natural gas burning fixtures.*

- 8. For all new development, or substantial modifications to existing development, a courtesy referral shall be provided to San Miguel County and the Town of Telluride consistent with the Referral and Review Process outlined in the Development Review Procedures. The Town is not bound by any referral comments from either jurisdiction.*

*Staff: A courtesy referral was provided to both the Town of Telluride and San Miguel County on January 7, 2021.*

## **Chapter 17.6: SUPPLEMENTARY REGULATIONS**

### **17.6.1: Environmental Regulations**

*Staff: Fire Mitigation and Forestry Management: Due to the location of the site, staff is requesting that the fire mitigation requirements be waived except. This will allow for additional vegetative screening to be maintained to mitigate visual impacts from the Mountain Village Center.*

*Steep Slopes: The building site does contain steep slopes and these areas have been identified as part of the topographic survey. This has been discussed above but due to the nature of the Unit – the steep slopes are impractical to avoid.*

### **17.6.6: Roads and Driveway Standards**

*Staff: The typical road and driveway standards do not apply to the ridge given its unique location and access. It would be helpful to better understand the grades of the parking area prior to final review. Staff is particularly interested in understanding the parking area as it relates to access to the site from Tunnel Lane.*

### **17.6.8: Solid Fuel Burning Device Regulations**

*Staff: The applicant has indicated that the proposed home does include fireplaces, and these are gas burning fixtures as required. The vents for these gas fireplaces are located on the rear of the home.*

## **Chapter 17.7: BUILDING REGULATIONS**

### **17.7.19: Construction Mitigation**

*Staff: The applicant has not submitted a CMP as part of this application. The importance of this plan for the future project should not be understated as there are a number of issues that are more complicated due to the site's unique location. The applicant will need to begin conversations with TSG in order to understand access to the site better. Additionally, staff has concerns related to excavation of the site and the associated spoils, material staging, stormwater mitigation, and other concerns typical of a large construction project with limited vehicular access. Staff recommends that these conversations are shared with the neighboring properties and projects under construction to try and minimize impacts collectively.*

**Staff Recommendation:** Staff recommends the DRB consider this request in relation to the CDC provisions listed above and particularly in Section 17.5.16: Ridgeline Lots to determine if the home is substantially complying with these provisions. If it's determined that the home does comply with these provisions, then staff recommends approval of the IASR, but if it's determined that these provisions are not being met then the item should be continued, and the applicant should revise the plans accordingly.

***Staff Note: It should be noted that reasons for approval or rejection should be stated in the findings of fact and motion.***

#### **Proposed Motion for Approval:**

If the DRB deems this application to be appropriate for approval, Staff requests said approval condition the items listed below in the suggested motion.

I move to approve the Initial Architectural and Site Review for a new single-family detached condominium located at Lot 161D-1 Unit 17, based on the evidence provided within the Staff Memo of record dated January 23, 2021, with the following conditions:

- 1) Prior to submittal for Final Architectural Review, the applicant will revise the civil engineering plan set to driveway widths and retaining wall locations/heights.
- 2) Prior to submittal for a Final Architectural Review, the applicant shall provide design and location details for the address monument, to include lighting details and any civil revisions for shallow utilities associated with the monument.
- 3) Prior to the submittal for a Final Architectural Review, the applicant shall revise the lighting plan per the comments in this report.
- 4) Prior to the submittal for a Final Architectural Review, the applicant shall revise the landscaping plan per the comments in this report.
- 5) Prior to the issuance of a building permit, the applicant shall field verify all utilities and submit a revised utility plan to the public works director identifying the location of utilities and connection points.
- 6) Consistent with town building codes, Unenclosed accessory structures attached to buildings with habitable spaces and projections, such as decks, shall be constructed as either non-combustible, heavy timber or exterior grade ignition resistant materials such as those listed as WUIC (Wildland Urban Interface Code) approved products.
- 7) A monumented land survey shall be prepared by a Colorado public land surveyor to establish the maximum building height and the maximum average building height.
- 8) A monumented land survey of the footers will be provided prior to pouring concrete to determine there are no additional encroachments into the common open-space.

- 9) Prior to the Building Division conducting the required framing inspection, a four-foot (4') by eight-foot (8') materials board will be erected on site consistent with the review authority approval to show:
- a. The stone, setting pattern, and any grouting with the minimum size of four feet (4') by four feet (4');
  - b. Wood that is stained in the approved color(s);
  - c. Any approved metal exterior material;
  - d. Roofing material(s); and
  - e. Any other approved exterior materials

/jjm



# Harris Residence - Unit 17 The Ridge Initial Architecture and Site Review

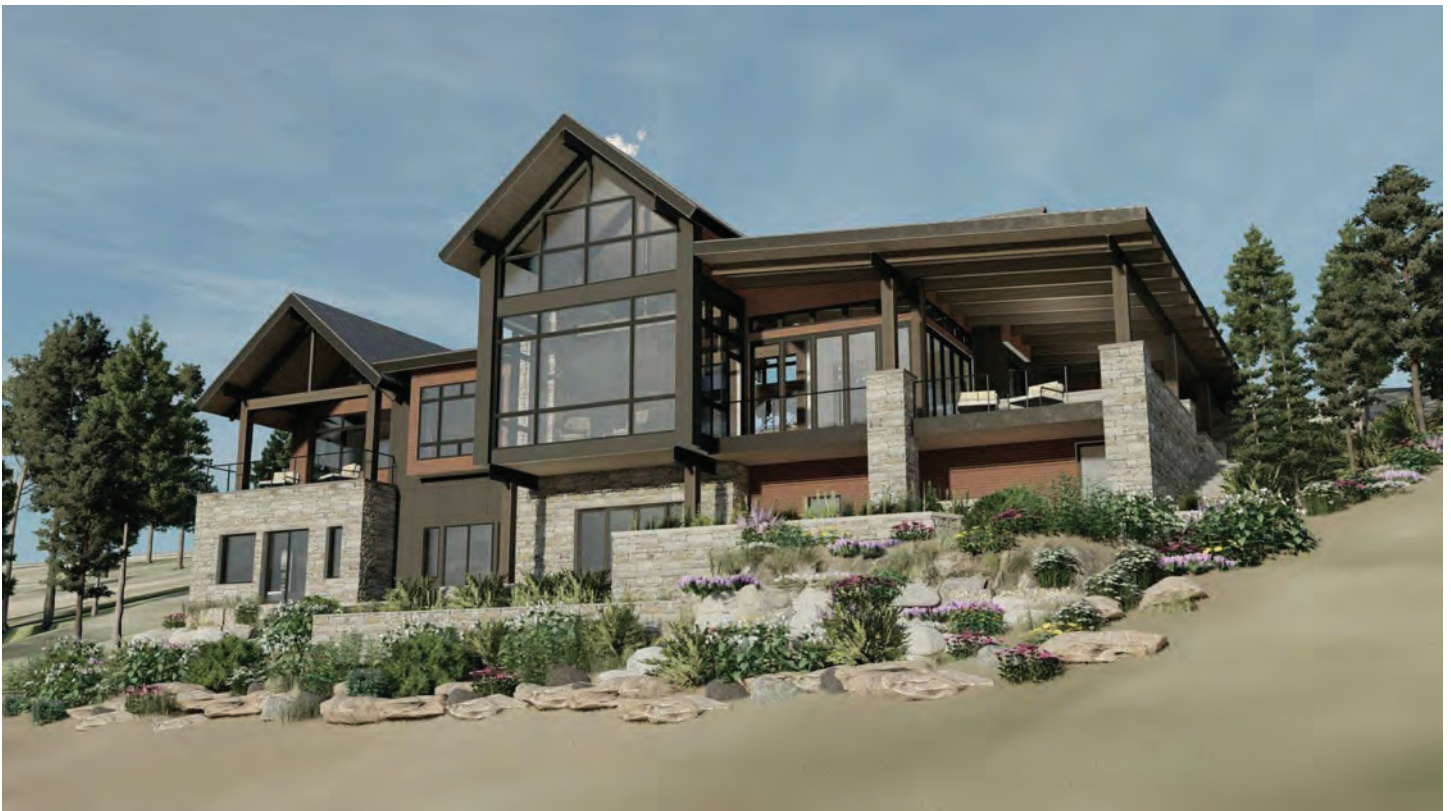

December 21, 2020



## Site Context and Design

Telluride Longview LLC, (“Owner”) is the owner of Unit 17, the Ridge at Telluride that has an assigned address of 6 Tunnel Lane, Unit 17 (“Site”). The Site is currently vacant and the Owner wishes to build a single-family dwelling within the Site. The Site is located in the Multi-Family Zone District and was created as a detached condominium unit.

The Site is located between Tunnel Lane and La Sal Lane on the southern edge of The Ridge Subdivision within the Telluride Mountain Village. The Ridge Subdivision primary access is intended to be by The Gondola where residents get off at the Angle Station and head down to a garage that contains golf carts that are then used to access each homesite by an a small concrete path that weaves through the development. Construction and limited summer access are provided through a primitive ski resort road.

The Site has a high elevation of 10467 feet and a low elevation of 10438 for an overall elevation gain of 29 feet with a slope of approximately 29.9%. The Site is vegetated with grass and wildflowers and no trees as can be seen in Figure 1.

The Site is platted as a condominium unit under the 5th Supplemented and Amended Planning Community Plat of the Ridge at Telluride - Phases 1, 2, 3, 4, 5, and 6 as recorded at Reception Number 409853 (5th Supplement).

Development within the Site is regulated by the Mountain Village Community Development Code (“CDC”) and by the Development Agreement for The Ridge at Telluride as recorded at Reception Number 365622 (“Development Agreement”).

## Project Geography

Geography and Zoning Requirements		
	Existing/Requirement	Proposed (Approx.)
Unit Size	7,500	No Change
Floor Area (Gross)		6,720 sq. ft.
Zone District	Multi-Family	No Change
Maximum Building Height	45’ per CDC Section 17.5.16(B)(3)	42’ - 4 1/2”
Maximum Average Building Height	Not Applicable to The Ridge	
Lot Coverage	CDC Lot Coverage is Not Applicable to The Ridge	NA
Setbacks	Not Applicable to The Ridge	NA
Parking	2 golf cart spaces per unit	2 enclosed golf cart spaces in garage

## The Ridge at Telluride Development Agreement

The Development Agreement has several requirements that are applicable to Unit 17 which are discussed further below. *See our response in blue italics.*

**3.2.3 DRB review and approval and San Miguel County and Town of Telluride review pursuant to the Ridge Covenant.** The Ridge Covenant was created and executed to ensure that development within The Ridge would not be visible from Telluride. Unit 17 is way below the geographic ridge and will not be visible from Telluride.

**3.2.6 Required Golf Cart Access.** The Development Agreement states: “Access on all roads, access tracts and driveways within the Project is restricted to golf carts.” *The Owners have included two spaces for parking golf*



Figure 1. The Site

*carts within an enclosed garage.*

**3.2.7 Maximum Number of Golf Carts.** The Development Agreement states: “Each Unit is allowed to have a maximum of two golf carts.” *The Owners do not intend to have more than two golf carts.*

**3.2.10 Trash Compactor Required.** The Development Agreement requires all units to have a trash compactor to facilitate the efficient removal of trash from The Ridge. *A trash compactor will be designed into the kitchen area.*

**3.2.11 Landscaping Buffers.** The Development Agreement and Site plat requires the provision of a landscaping buffer to the adjoining ski run. *The landscape buffer is discussed further under the Landscaping section.*

**3.2.12 Tree Removal.** The Development Agreement requires that the Town must approve tree removal which is consistent with the CDC Fire Mitigation and Forestry Management Regulations. *There are no trees present within or immediately adjacent to Unit 17.*

**3.2.13 Landscaping Installation.** The Development Agreement requires the Owners to be responsible for installing and maintaining landscaping as required for the Landscape Buffer Area and as may be required by the CDC Landscaping Regulations. *The Owners will install and maintain the landscaping as shown on the landscaping plan.*

**3.2.13 + 3.2.14 Tree Protection and Utility Routing.** The Development Agreement states: “In order to protect trees the possibility exists that the DRB may not allow utilities servicing a Unit to be installed along the shortest route from the main utility lines to the Unit.” *No trees will have to be removed for utilities as shown on the site plan.*

## Landscaping

The Ridge at Telluride Phase 1 Condominium Map, Note 9. Landscape Buffer Area states:

“Landscape Buffer Area” shall mean the landscape buffer area to be created on and around Units 17 (See Figure 2). . . If the Owners of these Units do not complete the required buffer improvements, then The Ridge At Telluride Homeowners Association, Inc. will be responsible to do so. The Landscape Buffer Area may contain such things that include but are not limited to berms, trees, walls, fences and vegetation. The purpose of the Landscape Buffer Area is to provide a buffer area between the adjacent ski run and the Development on the applicable Unit. If the DRB determines that an adequate buffer has been created, then structures and other improvements may be located in the balance of the Landscape Buffer Area. The provisions of this Note 9 may not be modified or deleted without the approval of the Town of Mountain Village.”

The Site landscaping plan has been designed to provide for the required landscaping buffer.

## Design Regulation Compliance

**Mountain Village Design Theme.** The proposed design meets the Mountain Village Design Theme. The project has been designed to sensitively fit the Site in order to minimize impacts to steep slopes and trees. The natural features of the site have informed the design of the home. The proposed home design is respectful and responsive to the tradition of alpine design with sturdy building forms, primary gable roof forms, secondary shed roof forms and a heavy grounded base. The massing is simple in form and is designed into the existing topography.

**Building Siting Design.** The building envelop guides the siting of the home, however the home has been design to blend into the existing landscape and hillside.

**Building Design.** The home has been designed with a stone base that provides a grounded building form to withstand high alpine conditions. The overall building form is simple in design with a primary north-south gable form and intersection cross gables. The roof has been designed with a composition of multiple forms that emphasize sloped plans, varied ridge lines and vertical offsets. The proposed standing seam steel roof provides a durable roof material that will withstand the high alpine climate conditions. Exterior materials are provided consistent with the Design Regulations as presented in this narrative. The exterior colors harmonize with the natural landscape and are natural, warm and subtle. Windows have been designed to be an integral part of the structure’s complete design and in accordance with the window regulations.

**Grading Design.** Grading has been designed to relate to and blend into the surrounding topographic landscape.

**Parking Regulations.** The Town; TMVOA; CO Lot 161C-R, LLC; and owners at The Ridge entered into a settlement agreement in 2019 that released several old parking and land use agreement in exchange for deeded parking spaces for The Ridge on Lot 161C-R. Most units at The Ridge were allocated one parking space on Lot 161C-R with an allowance to enter into a Reservation Agreement and escrow \$60,000 for a parking space by a set date; or to purchase a space based on construction costs at a latter date. Unit 17 executed a Reservation and Escrow Agreement and deposited the corresponding \$60,000 deposit for a deed parking space on June 6, 2019, per the parking settlement agreement. As such, Unit 17 currently parks on the surface of Lot 161C-R and will have a deeded parking space when covered parking is completed.

**Lot Coverage** - The maximum lot coverage limits set forth in CDC Section 17.3.13 do not apply to The Ridge since the Development Agreement and Master Development Plan are based on building envelopes that are now platted as condominium units. The Ridge concept is to locate buildings and driplines within the units that are surrounded by open space.

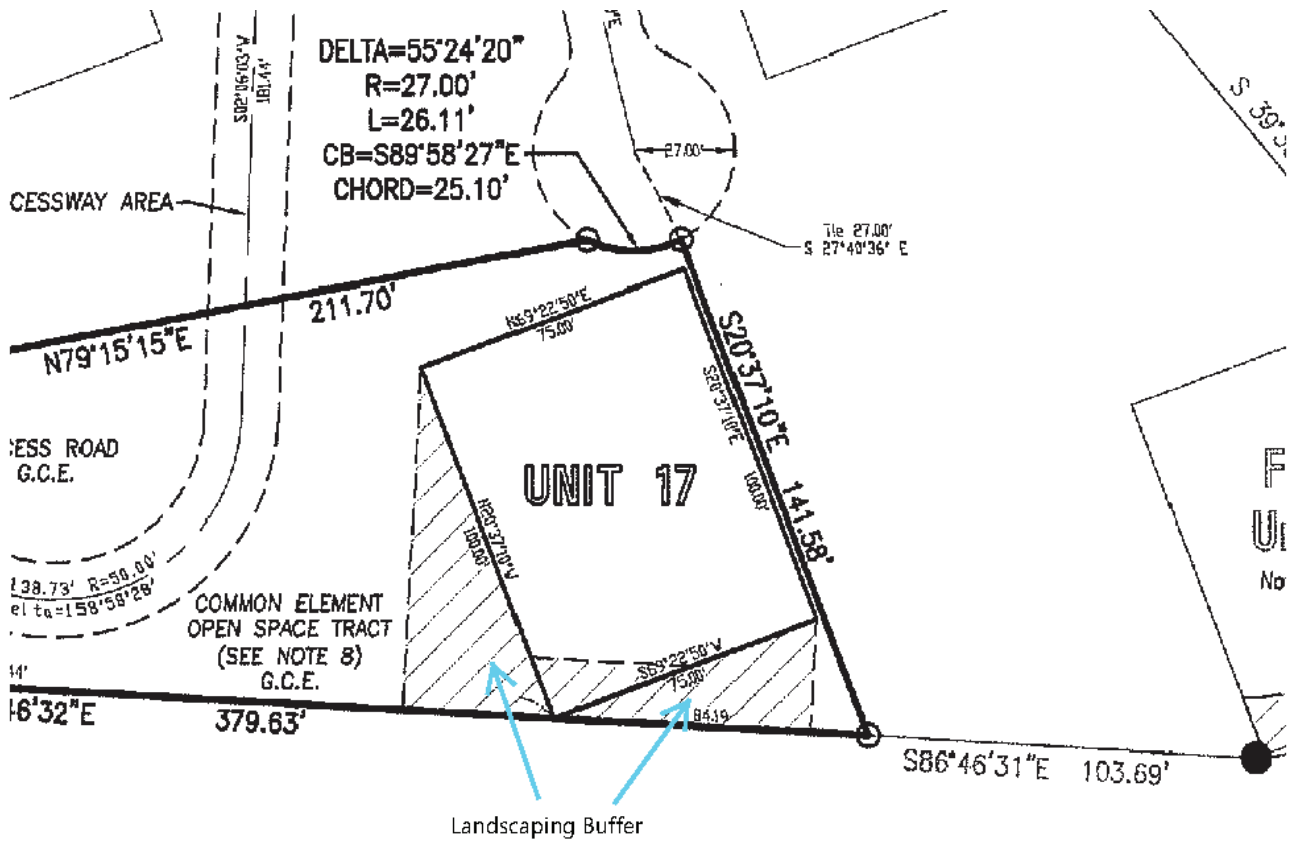

Figure 2. Landscape Buffers



Figure 3. Topographical Map

## Exterior Material & Roof Design

The proposed home is designed with the following exterior materials:

- Montana Custom Blend Dry Stack Stone Veneer (35% or greater)
- Equitone Cementitious Panel
- Corten Horizontal Metal Siding
- Timber Beams
- Black Metal Clad Windows and Doors
- Standing Seam Metal Roof

## Lighting

The lighting plan will be submitted for approval during Final Architectural Review consistent with the Design Review Process submittal requirements as well as consistent with guiding documents for The Ridge.

## Sites Adjacent to Open Space

CDC Section 17.5.5(D) states that: “Prior to the review authority approving the development of a site that proposes grading, clearing, direct drainage, direct access or other direct impact (as solely determined by the review authority) onto an adjoining open space, the applicant shall submit the proposed improvements on the open space to the owner of the affected open space for review and approval. We will be submitting the plans to TSG Ski and Golf, LLC for review due to the Unit 17 proximity to the adjoining ski run and the need for coordination, communication and potentially construction access from the ski run.

## Steep Slope Regulations

The Site has steep slopes that are greater than 30% as shown on the survey. Section 17.6.1(C)(2)(a) of the Community Development Code (“**CDC**”) states that:

“Building and development shall be located off slopes that are thirty percent (30%) or greater to the extent practical.

i. In evaluating practicable alternatives, the Town recognizes that it may be necessary to permit disturbance of slopes that are 30% or greater on a lot to allow access to key viewsheds, avoid other environmental issues, buffer development and similar site-specific design considerations.”

The development of the Site necessitates disturbance of steep slopes that are 30% or greater because such slopes are located in a small 7,500 sq. ft. building envelope. There is no way to avoid the steep slope areas in a small 7,500 sq. ft. building envelope and still allow for reasonable use of the Site.

CDC Section 17.6.1(C)(2)(c) states:

“The review authority shall only allow for disturbance to slopes thirty percent (30%) or greater if it is demonstrated that there is not a practicable alternative to avoiding such activities and if the following criteria are met:

i. The proposed steep slope disturbance is in general conformance with the Comprehensive Plan; *The proposed home is in general conformance with the Mountain Village Comprehensive Plan because it envisions The Ridge with Multi-family development.*

ii. The proposed disturbance is minimized to the extent practical. *There is no way to minimize disturbing the steep slope areas in a small 7,500 sq. ft. building envelope. Steep slope disturbance outside the building envelope will be minimized to the extent practical.*

iii. A Colorado professional engineer or geologist has provided: (a) A soils report or, for a subdivision, a geologic report. *A geotech report has been prepared for the Site.*

(b) An engineered civil plan for the lot, including grading and drainage plans. *Grading and drainage plans will be prepared by a Colorado P.E. for the final architectural review.*

iv. And the proposal provides mitigation for the steep slope development in accordance with the engineered plans." *Mitigation of steep slope development will be provided on the engineered grading and drainage plan.*



DRY-STACK STONE VENEER

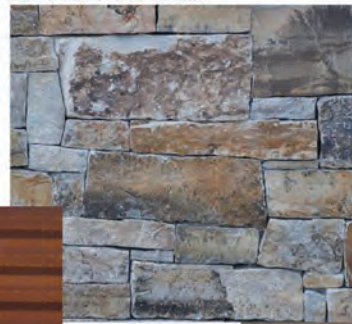

EQUITONE CEMENTITIOUS PANEL

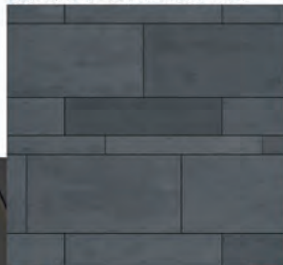

BLACK METAL WINDOW FRAMING



STANDING SEAM METAL ROOF

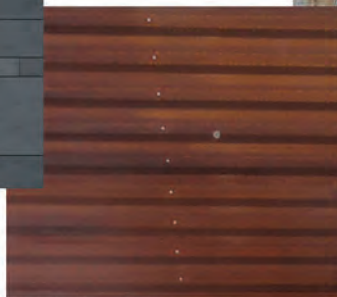

CORTEN HORIZONTAL METAL SIDING



TIMBER BEAMS









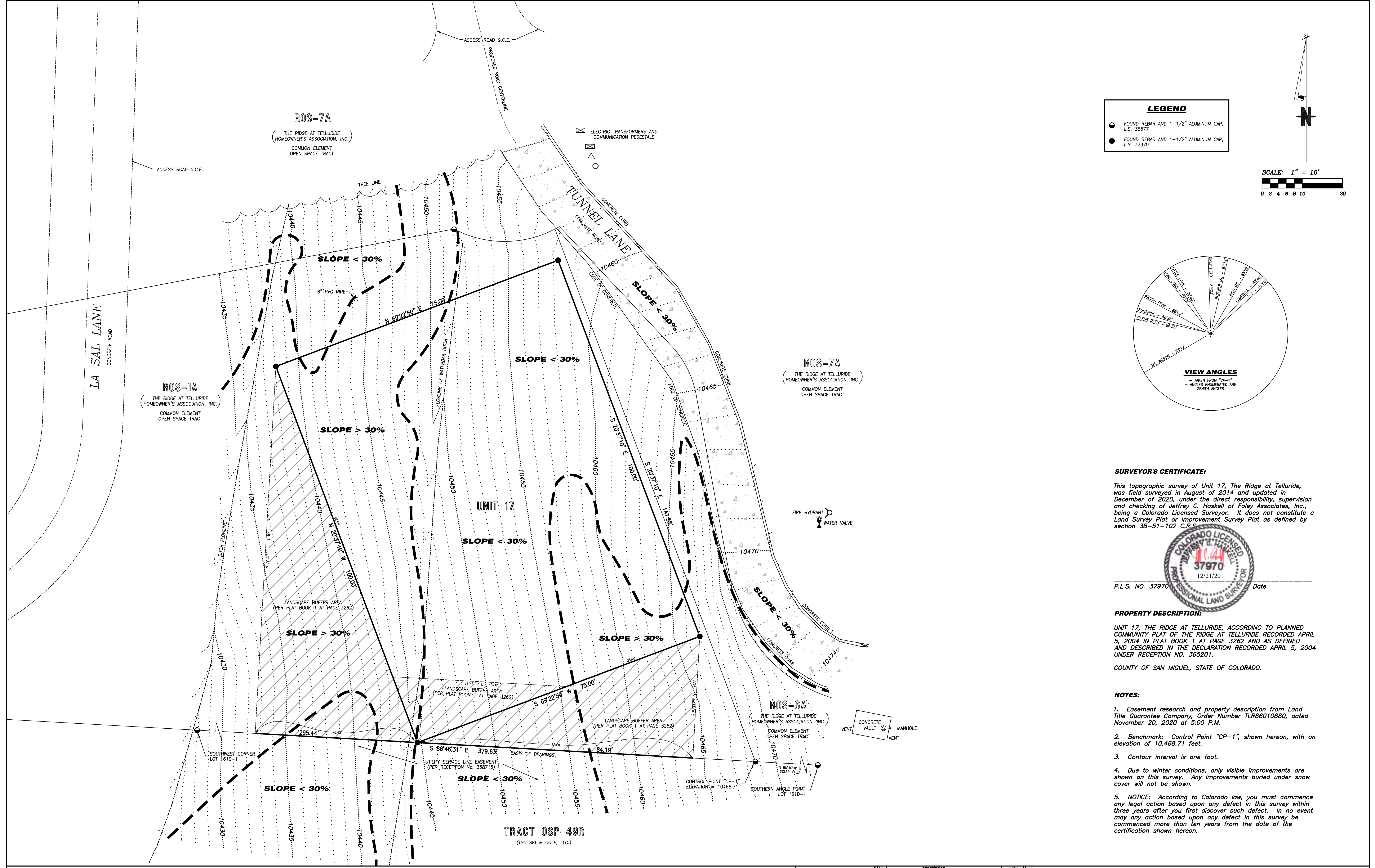

**LEGEND**

	FOUND REBAR AND 1-1/2" ALUMINUM CAP, L.S. 36577
	FOUND REBAR AND 1-1/2" ALUMINUM CAP, L.S. 37970

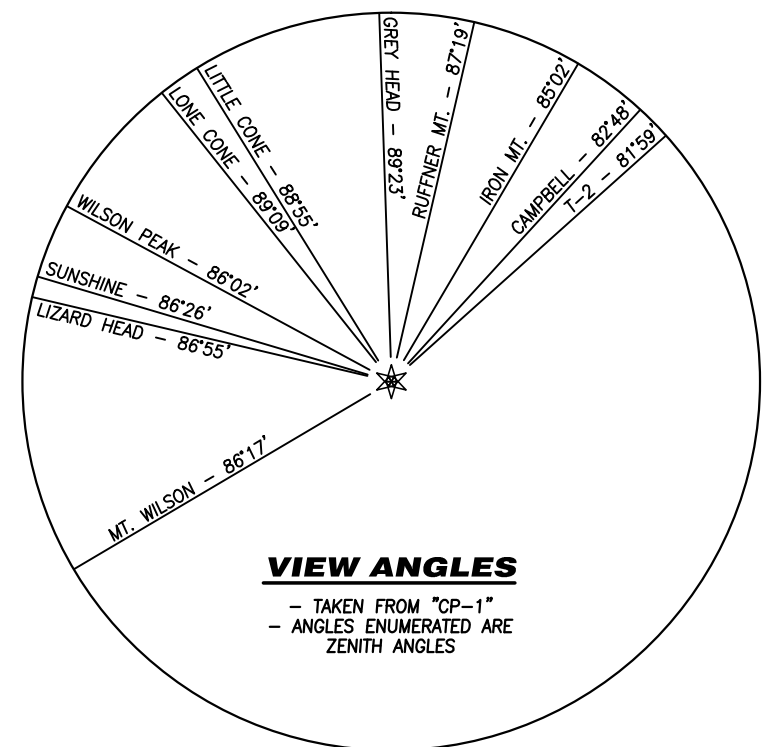
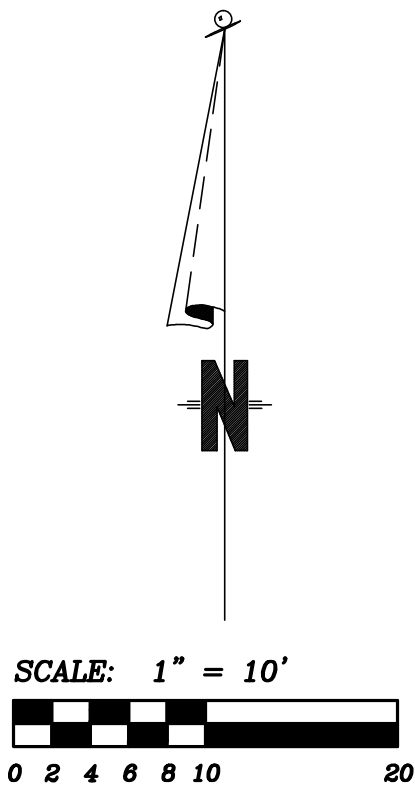

**SURVEYOR'S CERTIFICATE:**  
 This topographic survey of Unit 17, The Ridge at Telluride, was field surveyed in August of 2014 and updated in December of 2020, under the direct responsibility, supervision and checking of Jeffrey C. Haskell of Foley Associates, Inc., being a Colorado Licensed Surveyor. It does not constitute a Land Survey Plat or Improvement Survey Plat as defined by section 38-51-102 C.R.S.

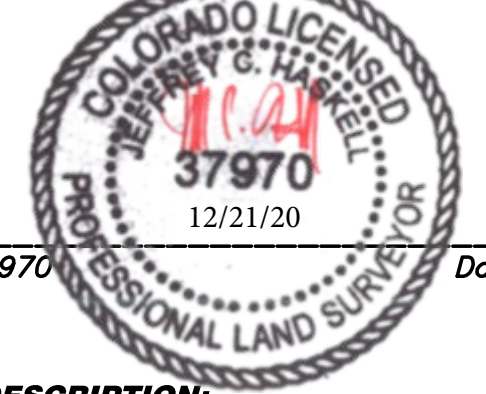

P.L.S. NO. 37970 Date

**PROPERTY DESCRIPTION:**  
 UNIT 17, THE RIDGE AT TELLURIDE, ACCORDING TO PLANNED COMMUNITY PLAT OF THE RIDGE AT TELLURIDE RECORDED APRIL 5, 2004 IN PLAT BOOK 1 AT PAGE 3262 AND AS DEFINED AND DESCRIBED IN THE DECLARATION RECORDED APRIL 5, 2004 UNDER RECEPTION NO. 365201,  
 COUNTY OF SAN MIGUEL, STATE OF COLORADO.

- NOTES:**
- Easement research and property description from Land Title Guarantee Company, Order Number TLR6010880, dated November 20, 2020 at 5:00 P.M.
  - Benchmark: Control Point "CP-1", shown hereon, with an elevation of 10,468.71 feet.
  - Contour interval is one foot.
  - Due to winter conditions, only visible improvements are shown on this survey. Any improvements buried under snow cover will not be shown.
  - NOTICE: According to Colorado law, you must commence any legal action based upon any defect in this survey within three years after you first discover such defect. In no event may any action based upon any defect in this survey be commenced more than ten years from the date of the certification shown hereon.

**Topographic Survey**  
 Unit 17, The Ridge at Telluride, Town of Mountain Village,  
 located within the NE1/4 of the SW1/4 of Section 2, T.42N, R.9W, N.M.P.M., County of San Miguel, State of Colorado.

Project Mgr:	JH
Technician:	FD
Checked by:	
Start date:	8 / 2014



970-728-6153 970-728-6050 fax  
 P.O. BOX 1385  
 125 W. PACIFIC, SUITE B-1  
 TELLURIDE, COLORADO 81435

F:\014 W\Jobs\11055\111055.dwg, 12/21/2020 2:47:29 PM, PCL



VERTICAL ARTS ARCHITECTURE  
Design | Planning | Interiors

Copyright VERTICAL ARTS, INC. All Rights Reserved  
This document, and the ideas and designs incorporated herein, as an instrument of professional service, is the property of Vertical Arts, Inc. and is not to be used, in whole or in part, for any other project without the written authorization from a principal of Vertical Arts, Inc.

# Harris Residence Unit 17 - The Ridges at Telluride Town of Mountain Village, Colorado

ISSUE NAME	DATE
PLAN REVIEW	12.18.20

DRAWING TITLE  
**Site and Grading Plan**

SHEET NO.



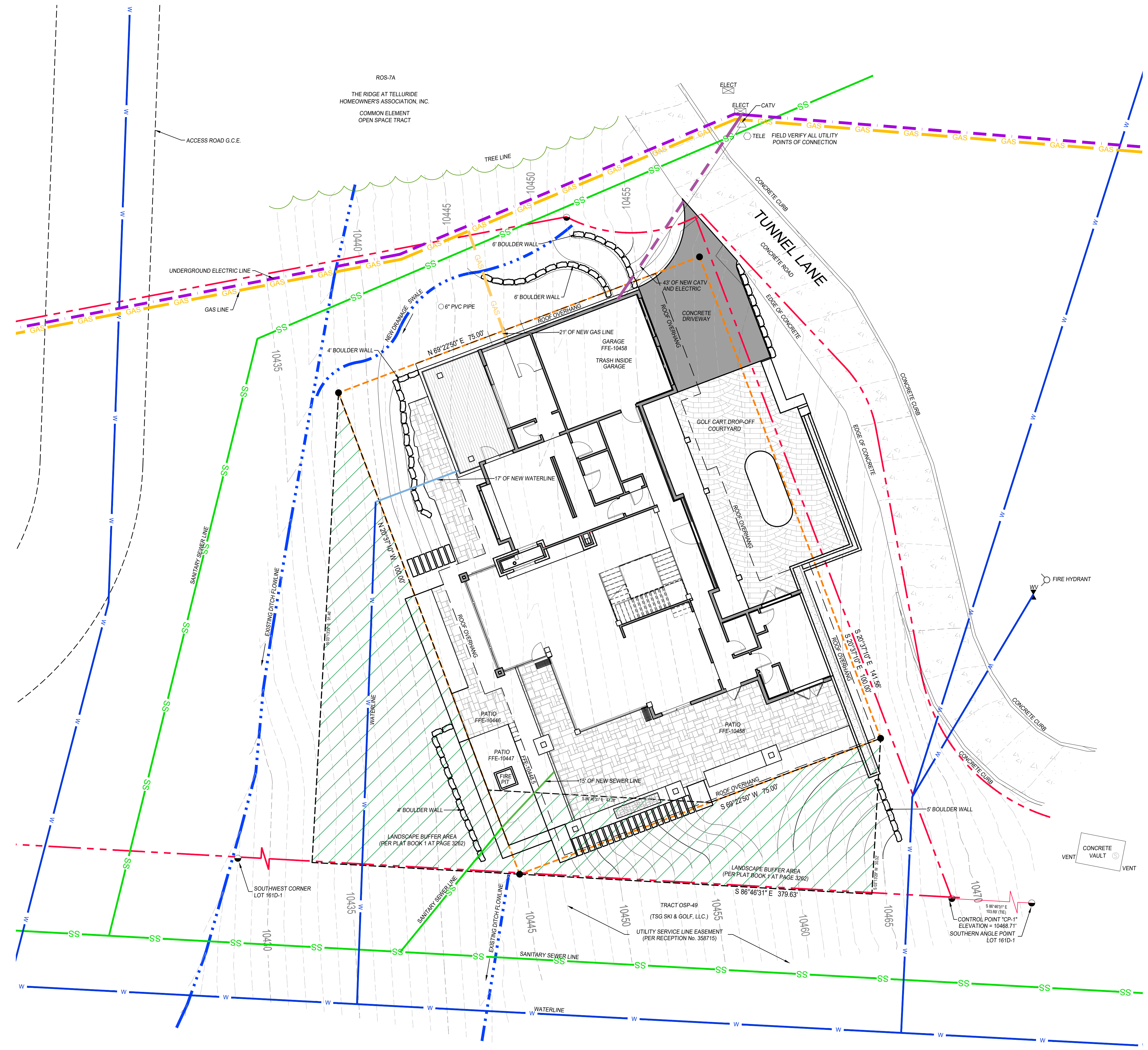



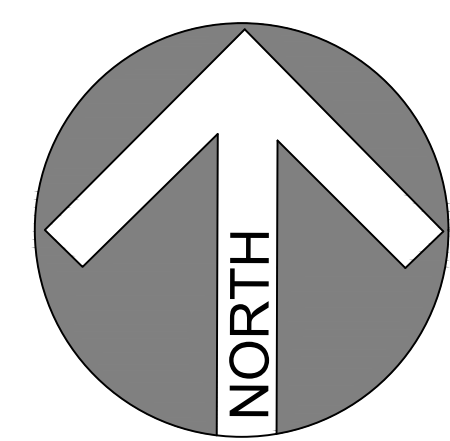
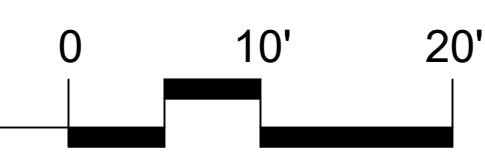







**SP-1**



1 Site and Grading Plan - Unit 17  
SCALE: 1"=10'-0"



LANDSCAPE LEGEND

-  BOULDER WALLS
-  PERENNIAL PLANTINGS
-  LARGE DECIDUOUS SHRUBS
-  LANDSCAPE ROCK & MULCH PLANTING BEDS
-  DRIP IRRIGATED
-  CUT STONE LANDSCAPE EDGER
-  ASPEN TREES
-  EVERGREEN SHRUBS
-  DECIDUOUS SHRUBS
-  DRIP IRRIGATED
-  LANDSCAPE ROCK & MULCH PLANTING BEDS
-  DECIDUOUS SHRUBS
-  EVERGREEN TREES
-  IRRIGATED NATIVE SEED MIX

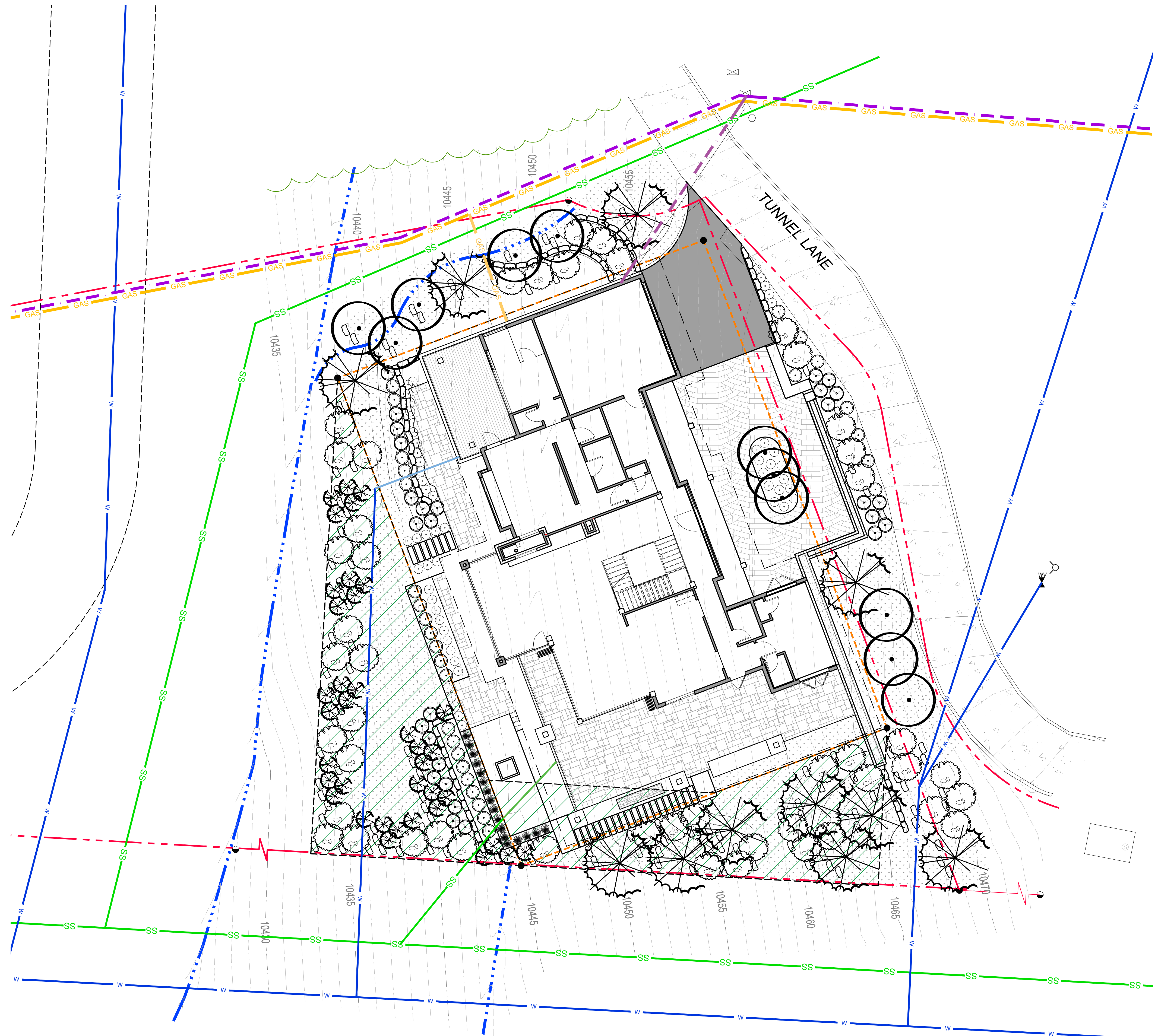

ARCHITECTURE  
Design | Planning | Interiors

Copyright VERTICAL ARTS, INC. All Rights Reserved.  
This document, and the ideas and designs incorporated herein, are an instrument of professional service, the property of Vertical Arts, Inc. and is not to be used, in whole or in part, for any other project without the written authorization from a principal of Vertical Arts, Inc.

Harris Residence  
Unit 17 - The Ridges at Telluride  
Town of Mountain Village, Colorado

ISSUE NAME	DATE
PLAN REVIEW	12.18.20

DRAWING TITLE  
Conceptual Landscape Plan

SHEET NO.  
L-1

1 Conceptual Landscape Plan - Unit 17  
SCALE: 1"=10'-0"

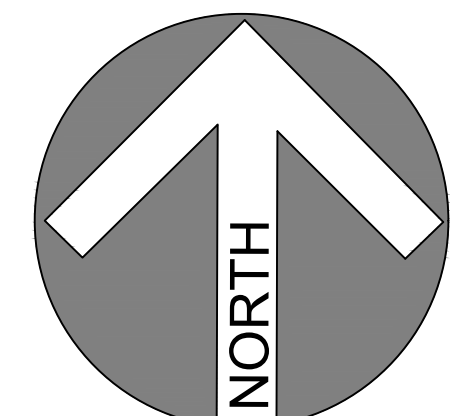
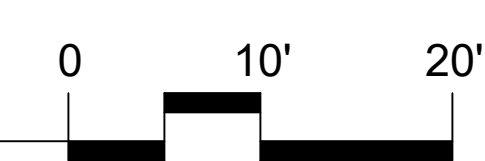

GENERAL NOTES:

1. ALL EXTERIOR WALLS TO BE 2x6 U.N.O. - VERIFY WITH STRUCTURAL DRAWINGS.
2. ALL INTERIOR WALLS TO BE 2x4 U.N.O. - VERIFY WITH STRUCTURAL DRAWINGS.
3. ALL DOORS TO BE 6" OFF ADJACENT WALL OR CENTERED WITHIN ROOM U.N.O. STONE THICKNESS ASSUMED TO BE 6" IN DEPTH. VERIFY STONE THICKNESS BEFORE FRAMING.



ARCHITECTURE  
PLANNING  
LANDSCAPE  
INTERIORS

Copyright VERTICAL ARTS, INC.  
All Rights Reserved

This document, and the ideas and designs incorporated herein, as an instrument of professional service, is the property of Vertical Arts Inc. and is not to be used, in whole or in part, for any other project without the written authorization from a principal of Vertical Arts, Inc.

HARRIS RESIDENCE  
6 TUNNEL LANE, UNIT 17  
MOUNTAIN VILLAGE, CO 81435  
2041

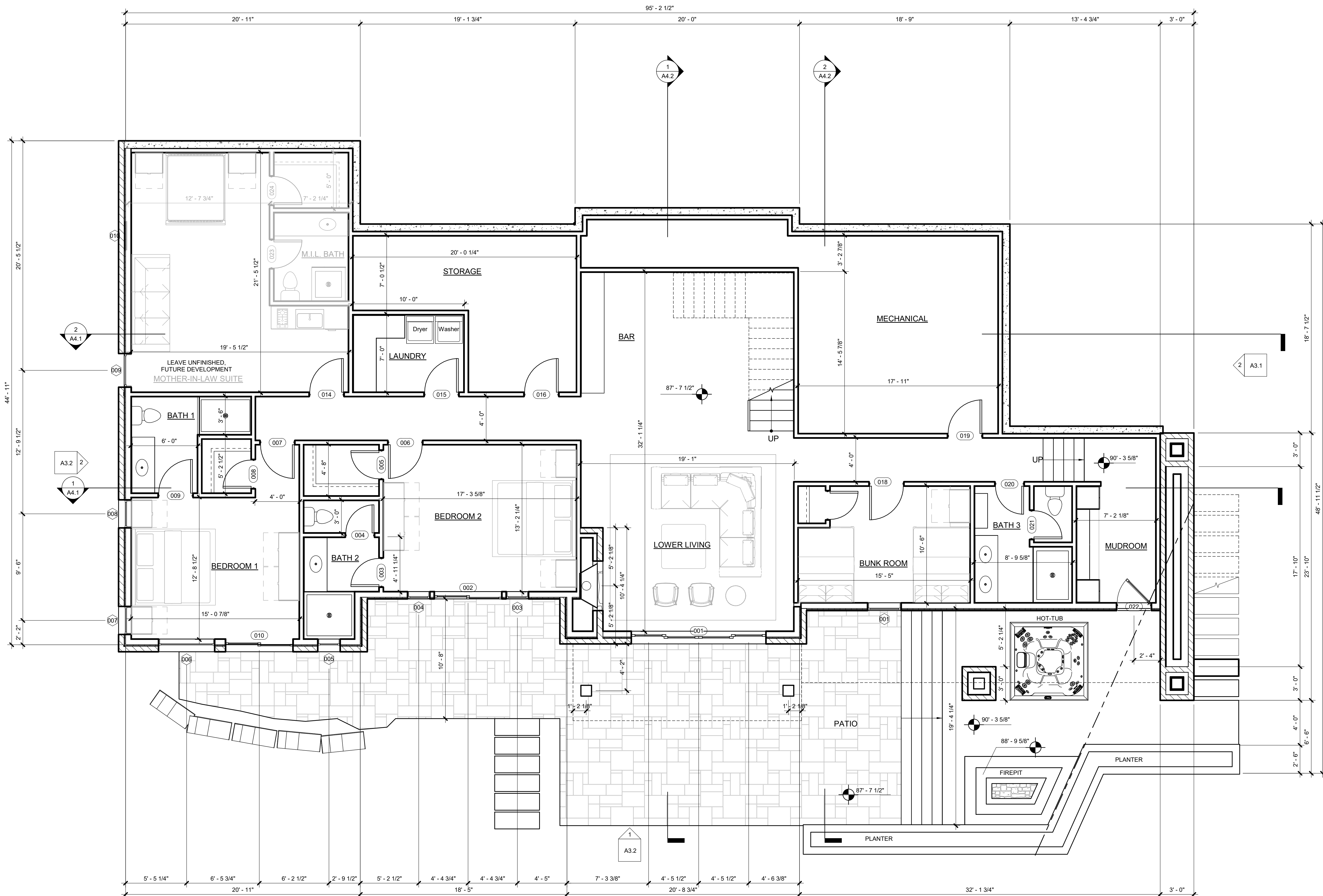

1 LOWER LEVEL FLOOR PLAN  
1/4" = 1'-0"



ISSUE NAME	DATE
1 100% SD	12/18/20
2 DRB INITIAL REVIEW	12/18/20

DRAWING TITLE  
LOWER LEVEL FLOOR PLAN

SHEET NO.

A2.1

12/18/2020 3:20:31 PM

GENERAL NOTES:

1. ALL EXTERIOR WALLS TO BE 2x6 U.N.O. - VERIFY WITH STRUCTURAL DRAWINGS.
2. ALL INTERIOR WALLS TO BE 2x4 U.N.O. - VERIFY WITH STRUCTURAL DRAWINGS.
3. ALL DOORS TO BE 6" OFF ADJACENT WALL OR CENTERED WITHIN ROOM U.N.O. STONE THICKNESS ASSUMED TO BE 6" IN DEPTH. VERIFY STONE THICKNESS BEFORE FRAMING.



VERTICAL  
ARTS  
ARCHITECTURE  
PLANNING  
LANDSCAPE  
INTERIORS

Copyright VERTICAL ARTS, INC.  
All Rights Reserved.  
This document, and the ideas and designs incorporated herein, are an instrument of professional service, is the property of Vertical Arts Inc. and is not to be used, in whole or in part, for any other project without the written authorization from a principal of Vertical Arts, Inc.

HARRIS RESIDENCE  
6 TUNNEL LANE, UNIT 17  
MOUNTAIN VILLAGE, CO 81435  
2041

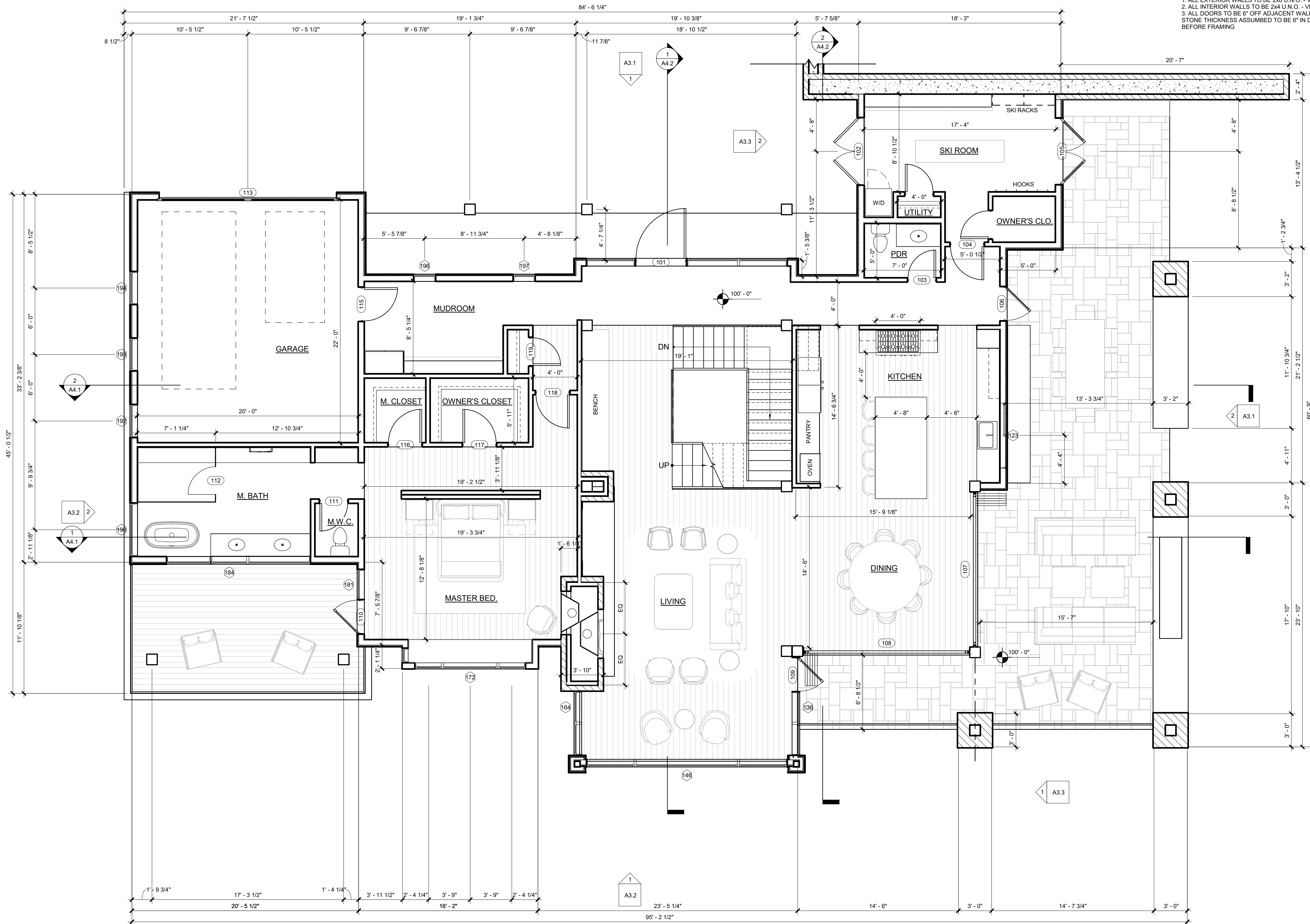

1 MAIN LEVEL FLOOR PLAN  
1/4" = 1'-0"



ISSUE NAME	DATE
1 100% SD	12/18/20
2 DRB INITIAL REVIEW	12/18/20

DRAWING TITLE  
MAIN LEVEL FLOOR PLAN

SHEET NO.

A2.2

12/18/2020 3:20:34 PM



ARCHITECTURE  
PLANNING  
LANDSCAPE  
INTERIORS

Copyright VERTICAL ARTS, INC.  
All Rights Reserved  
This document, and the ideas and designs incorporated herein, are an instrument of professional service, is the property of Vertical Arts Inc. and is not to be used, in whole or in part, for any other project without the written authorization from a principal of Vertical Arts, Inc.

HARRIS RESIDENCE  
6 TUNNEL LANE, UNIT 17  
MOUNTAIN VILLAGE, CO 81435  
2041

- GENERAL NOTES:
1. ALL EXTERIOR WALLS TO BE 2x6 U.N.O. - VERIFY WITH STRUCTURAL DRAWINGS.
  2. ALL INTERIOR WALLS TO BE 2x4 U.N.O. - VERIFY WITH STRUCTURAL DRAWINGS.
  3. ALL DOORS TO BE 6" OFF ADJACENT WALL OR CENTERED WITHIN ROOM U.N.O. STONE THICKNESS ASSUMED TO BE 6" IN DEPTH. VERIFY STONE THICKNESS BEFORE FRAMING

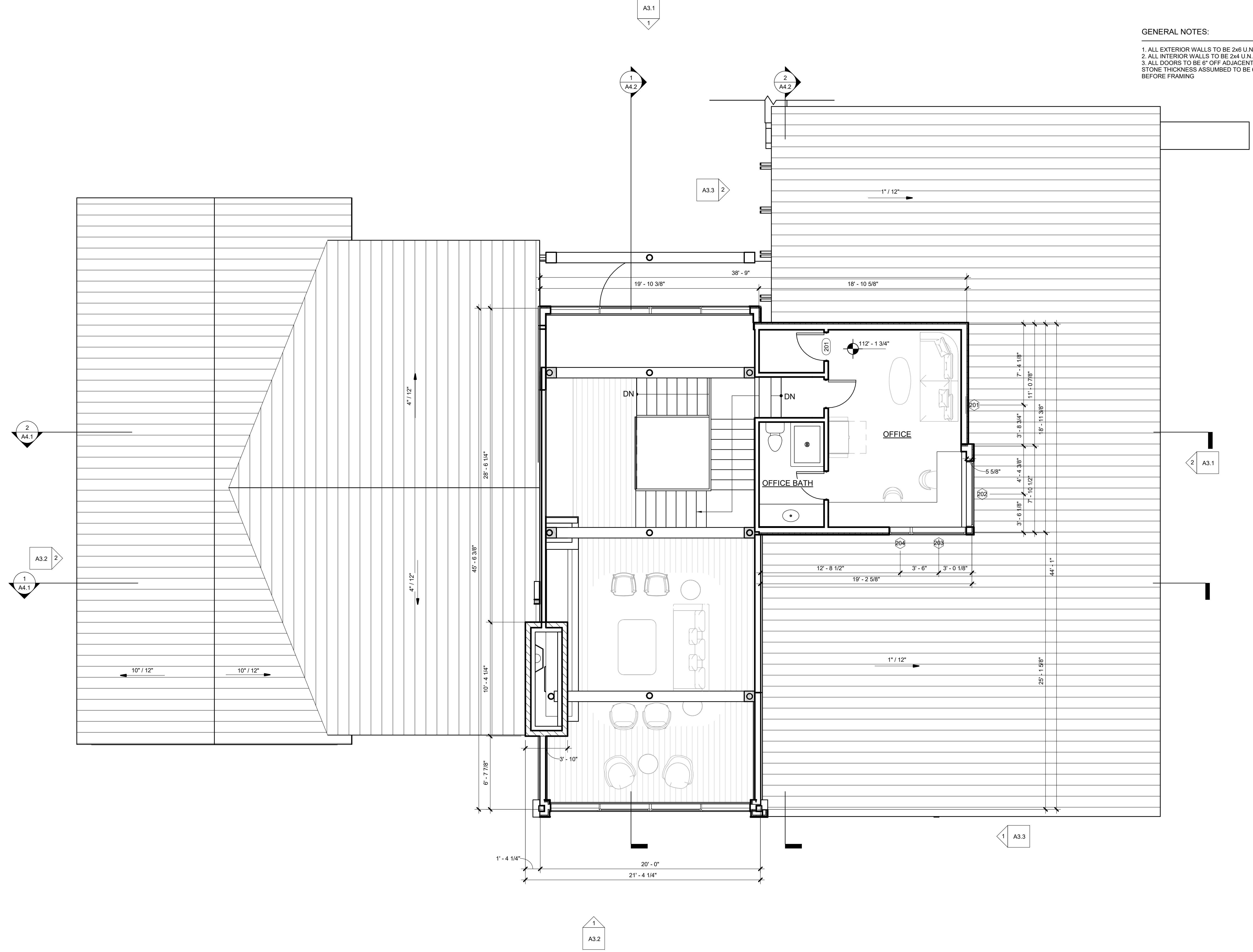

1 UPPER LEVEL FLOOR PLAN  
1/4" = 1'-0"



ISSUE NAME	DATE
1 100% SD	12/18/20
2 DRB INITIAL REVIEW	12/18/20

DRAWING TITLE  
UPPER LEVEL FLOOR PLAN

SHEET NO.  
A2.3

12/18/2020 3:20:36 PM







VERTICAL ARTS ARCHITECTURE  
Design | Planning | Interiors

Copyright VERTICAL ARTS, INC. All Rights Reserved  
This document, and the ideas and designs incorporated herein, as an instrument of professional service, is the property of Vertical Arts, Inc. and is not to be used, in whole or in part, for any other project without the written authorization from a principal of Vertical Arts, Inc.

# Harris Residence Unit 17 - The Ridges at Telluride Town of Mountain Village, Colorado

ISSUE NAME	DATE
PLAN REVIEW	12.18.20

DRAWING TITLE  
**Roof Plan Topography**

SHEET NO.

# A2.5

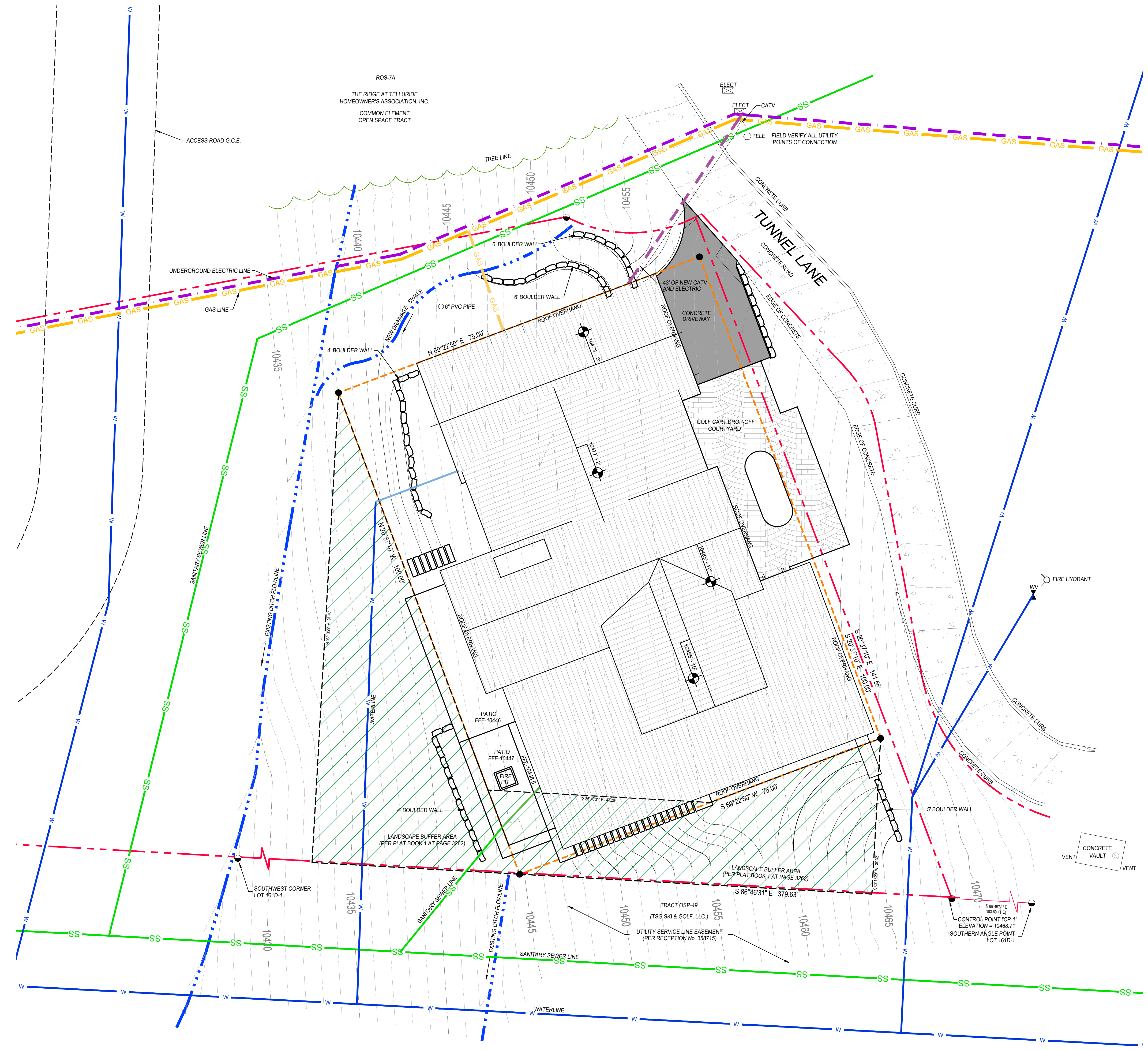

1 Roof Plan Topography  
SCALE: 1"=10'-0"

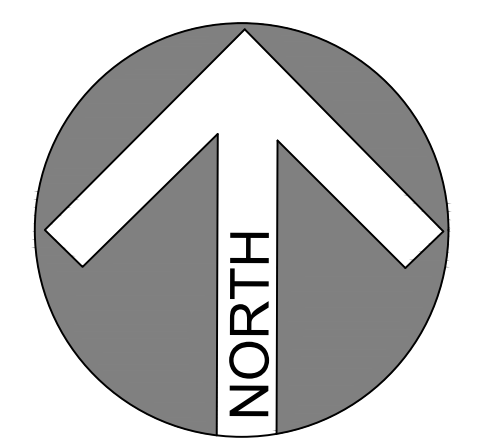
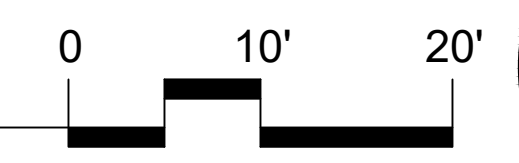

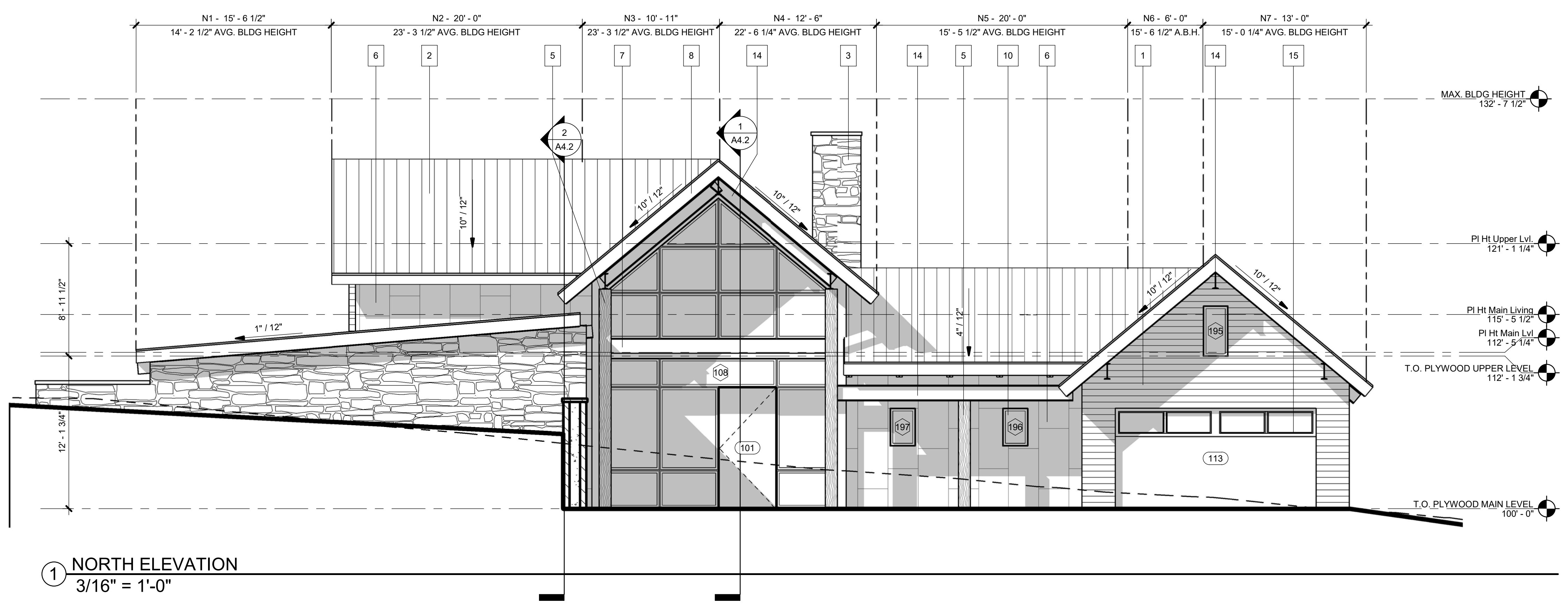

① NORTH ELEVATION  
3/16" = 1'-0"

EXTERIOR WINDOWS CALCULATIONS	
Type	Area
EAST 320.72 WIN. / 1264.95 TOTAL = 25.4%	
WINDOW	320.72 SF
WALL	944.23 SF
1264.95 SF	
NORTH 372.40 WIN. / 1324.44 TOTAL = 28.1%	
WINDOW	372.40 SF
WALL	952.04 SF
1324.44 SF	
SOUTH 1001.68 WIN. / 2763.51 TOTAL = 36.2%	
WINDOW	1001.68 SF
WALL	1761.83 SF
2763.51 SF	
WEST 253.20 WIN. / 1539.76 TOTAL = 16.4%	
WINDOW	253.20 SF
WALL	1286.56 SF
1539.76 SF	
(25.4% + 28.1% + 36.2% + 16.4%) / 4 =	
<b>26.5% TOTAL WINDOW COVERAGE</b>	
<b>CDC REQ. - 40% MAX. WINDOW COVERAGE</b>	

EXTERIOR MATERIAL CALCULATIONS	
Type	Area
EAST 349.52 STONE / 1403.03 TOTAL = 24.9%	
EXT STONE	349.52 SF
WALL	1053.51 SF
1403.03 SF	
NORTH 660.97 STONE / 1755.68 TOTAL = 37.6%	
EXT STONE	660.97 SF
WALL	1094.71 SF
1755.68 SF	
SOUTH 1065.00 STONE / 2994.41 TOTAL = 35.6%	
EXT STONE	1065.00 SF
WALL	1929.41 SF
2994.41 SF	
WEST 732.50 STONE / 1415.26 TOTAL = 51.8%	
EXT STONE	732.50 SF
WALL	682.76 SF
1415.26 SF	
(24.9% + 37.6% + 35.6% + 51.8%) / 4 =	
<b>37.5% TOTAL STONE COVERAGE</b>	
<b>CDC REQ. - 35% MIN. STONE COVERAGE</b>	

AVG. BUILDING HEIGHT - NORTH	
Number	Height
N1	14' - 2 1/2"
N2	23' - 3 1/2"
N3	23' - 3 1/2"
N4	22' - 6 1/4"
N5	15' - 5 1/2"
N6	15' - 6 1/2"
N7	15' - 0 1/4"
129' - 4" / 7 =	
18' - 5 3/4"	
NORTHERN AVG. BLDG HEIGHT	

AVG. BUILDING HEIGHT - EAST	
Number	Height
E1	34' - 10 3/4"
E2	34' - 10 3/4"
E3	34' - 10 3/4"
E4	26' - 6 1/4"
131' - 2 1/2" / 4 =	
32' 9 1/2"	
EASTERN AVG. BLDG HEIGHT	

AVG. BUILDING HEIGHT - TOTAL	
Number	Height
EAST	32' - 9 1/2"
WEST	27' - 4 3/4"
SOUTH	36' - 4"
NORTH	18' - 5 3/4"
115' - 0" / 4 =	
28' - 9"	
TOTAL AVG. BLDG HEIGHT	
30' - 0" ALLOWED	
MAX AVG. BLDG HEIGHT	

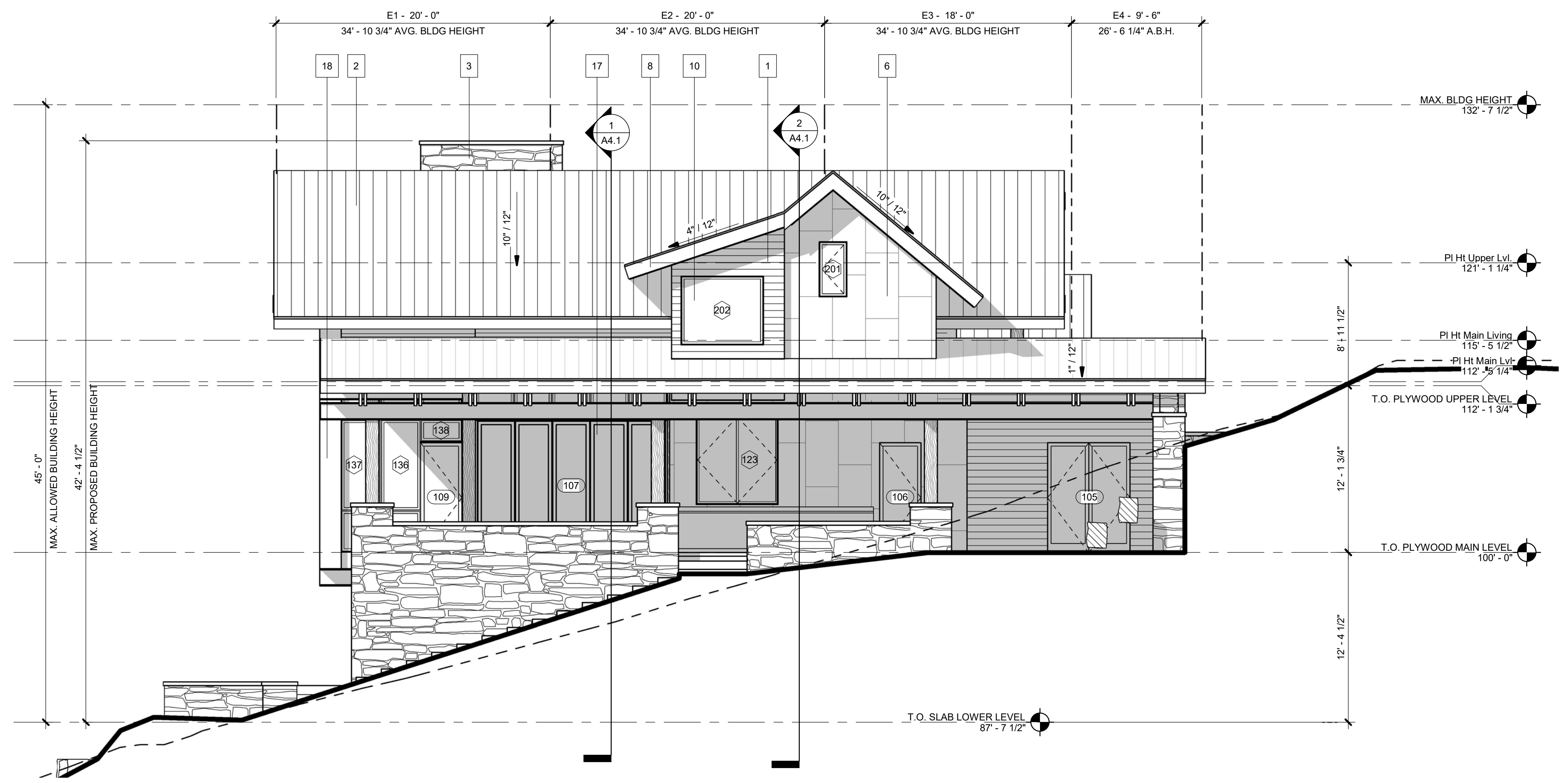

② EAST ELEVATION  
3/16" = 1'-0"

KEYNOTE LEGEND	
Key Value	Keynote Text
1	CORRUGATED CORTEN
2	STANDING SEAM METAL ROOF
3	TELLURIDE STONE RE: MASON
4	STEEL CABLE RAILING
5	TIMBER COLUMN
6	EQUITONE PANEL NATURA N281
7	TIMBER BEAM
8	1x12 PAINTED COMPOSITE WOOD FASCIA
10	STEEL WINDOWS - JELD-WEN
14	STEEL I-BEAM
15	CUSTOM GARAGE DOOR
17	FOLDING GLASS DOOR
18	BLACK METAL

ISSUE NAME	DATE
1 100% SD	12/18/20
2 DRB INITIAL REVIEW	12/18/20

DRAWING TITLE  
EXTERIOR ELEVATIONS

SHEET NO.

A3.1



VERTICAL  
ARTS  
ARCHITECTURE  
PLANNING  
LANDSCAPE  
INTERIORS

Copyright VERTICAL ARTS, INC.  
All Rights Reserved  
This document, and the ideas and designs incorporated herein, are an instrument of professional service, is the property of Vertical Arts Inc. and is not to be used, in whole or in part, for any other project without the written authorization from a principal of Vertical Arts, Inc.

HARRIS RESIDENCE  
6 TUNNEL LANE, UNIT 17  
MOUNTAIN VILLAGE, CO 81435  
2041



EXTERIOR WINDOWS CALCULATIONS	
Type	Area
<b>EAST</b> 320.72 WIN. / 1264.95 TOTAL = 25.4%	
WINDOW	320.72 SF
WALL	944.23 SF
	1264.95 SF
<b>NORTH</b> 372.40 WIN. / 1324.44 TOTAL = 28.1%	
WINDOW	372.40 SF
WALL	952.04 SF
	1324.44 SF
<b>SOUTH</b> 1001.68 WIN. / 2763.51 TOTAL = 36.2%	
WINDOW	1001.68 SF
WALL	1761.83 SF
	2763.51 SF
<b>WEST</b> 253.20 WIN. / 1539.76 TOTAL = 16.4%	
WINDOW	253.20 SF
WALL	1286.56 SF
	1539.76 SF
(25.4% + 28.1% + 36.2% + 16.4%) / 4 =	
<b>26.5% TOTAL WINDOW COVERAGE</b>	
<b>CDC REQ. - 40% MAX. WINDOW COVERAGE</b>	

EXTERIOR MATERIAL CALCULATIONS	
Type	Area
<b>EAST</b> 349.52 STONE / 1403.03 TOTAL = 24.9%	
EXT STONE	349.52 SF
WALL	1053.51 SF
	1403.03 SF
<b>NORTH</b> 660.97 STONE / 1755.68 TOTAL = 37.6%	
EXT STONE	660.97 SF
WALL	1094.71 SF
	1755.68 SF
<b>SOUTH</b> 1065.00 STONE / 2994.41 TOTAL = 35.6%	
EXT STONE	1065.00 SF
WALL	1929.41 SF
	2994.41 SF
<b>WEST</b> 732.50 STONE / 1415.26 TOTAL = 51.8%	
EXT STONE	732.50 SF
WALL	682.76 SF
	1415.26 SF
(24.9% + 37.6% + 35.6% + 51.8%) / 4 =	
<b>37.5% TOTAL STONE COVERAGE</b>	
<b>CDC REQ. - 35% MIN. STONE COVERAGE</b>	

1 SOUTH ELEVATION  
3/16" = 1'-0"

AVG. BUILDING HEIGHT - SOUTH	
Number	Height
S1	27' - 4 3/4"
S2	27' - 10"
S3	27' - 10"
S4	34' - 10 3/4"
S5	36' - 9"
S6	36' - 9"
S7	26' - 7 1/4"
218' - 0 3/4" / 6 =	
36' - 4"	
SOUTHERN AVG. BLDG HEIGHT	

AVG. BUILDING HEIGHT - WEST	
Number	Height
W1	27' - 4 3/4"
W2	27' - 4 3/4"
W3	27' - 4 3/4"
82' - 2 1/4" / 3 =	
27' - 4 3/4"	
WESTERN AVG. BLDG HEIGHT	

AVG. BUILDING HEIGHT - TOTAL	
Number	Height
EAST	32' - 9 1/2"
WEST	27' - 4 3/4"
SOUTH	36' - 4"
NORTH	18' - 5 3/4"
115' - 0" / 4 =	
28' - 9"	
TOTAL AVG. BLDG HEIGHT	
30' - 0" ALLOWED	
MAX AVG. BLDG HEIGHT	

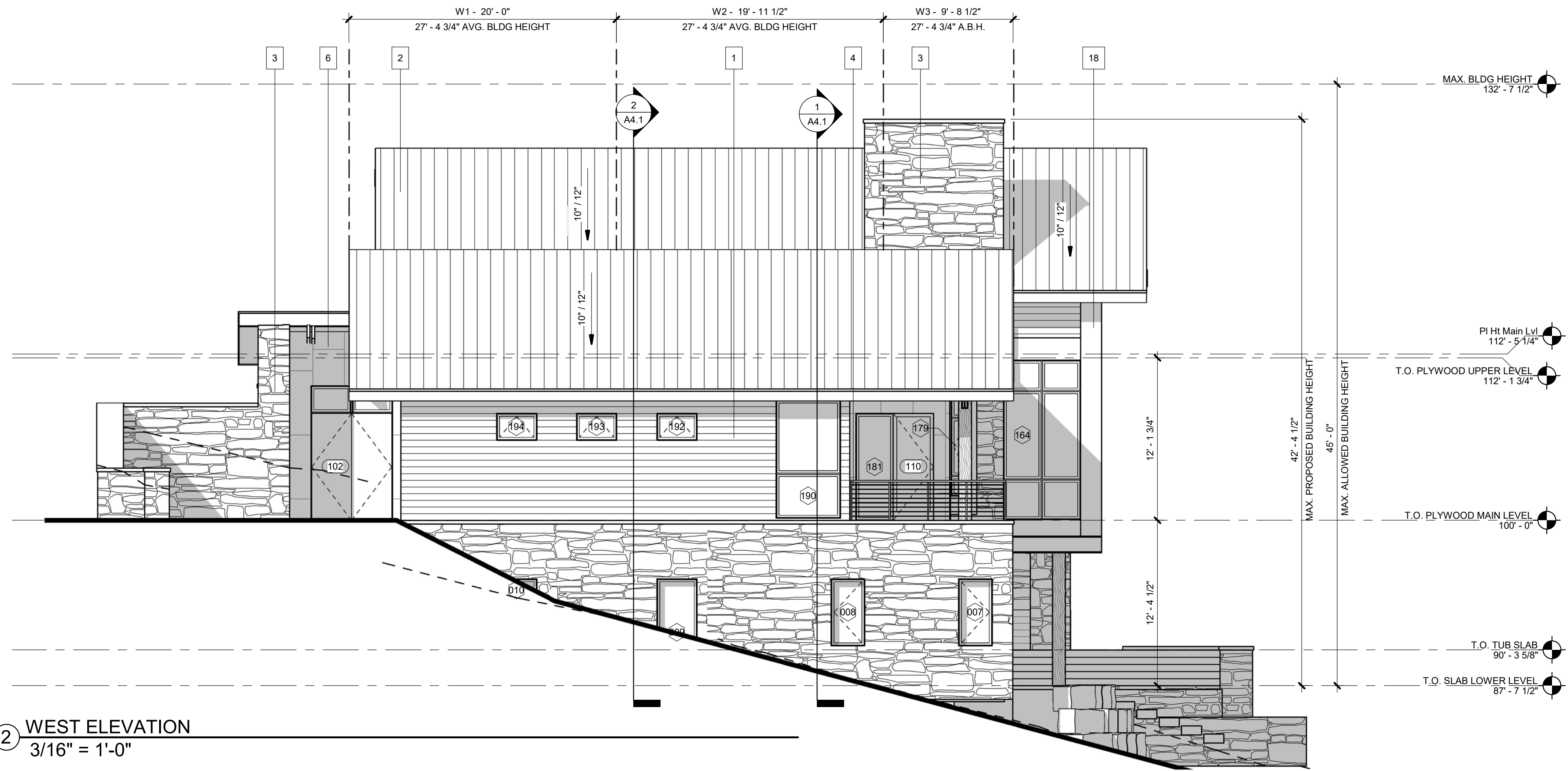

2 WEST ELEVATION  
3/16" = 1'-0"

KEYNOTE LEGEND	
Key Value	Keynote Text
1	CORRUGATED CORTEN
2	STANDING SEAM METAL ROOF
3	TELLURIDE STONE RE: MASON
4	STEEL CABLE RAILING
5	TIMBER COLUMN
6	EQUITONE PANEL NATURA N281
7	TIMBER BEAM
8	1x12 PAINTED COMPOSITE WOOD FASCIA
10	STEEL WINDOWS - JELD-WEN
14	STEEL I-BEAM
15	CUSTOM GARAGE DOOR
17	FOLDING GLASS DOOR
18	BLACK METAL

ISSUE NAME	DATE
1 100% SD	12/18/20
2 DRB INITIAL REVIEW	12/18/20

DRAWING TITLE  
EXTERIOR ELEVATIONS

SHEET NO.

A3.2



ARCHITECTURE  
PLANNING  
LANDSCAPE  
INTERIORS

Copyright VERTICAL ARTS, INC.  
All Rights Reserved  
This document, and the ideas and designs incorporated herein, are an instrument of professional service, is the property of Vertical Arts Inc. and is not to be used, in whole or in part, for any other project without the written authorization from a principal of Vertical Arts, Inc.

KEYNOTE LEGEND	
Key Value	Keynote Text
1	CORRUGATED CORTEN
2	STANDING SEAM METAL ROOF
3	TELLURIDE STONE RE: MASON
4	STEEL CABLE RAILING
5	TIMBER COLUMN
6	EQUITONE PANEL NATURA N281
7	TIMBER BEAM
8	1x12 PAINTED COMPOSITE WOOD FASCIA
10	STEEL WINDOWS - JELD-WEN
14	STEEL I-BEAM
15	CUSTOM GARAGE DOOR
17	FOLDING GLASS DOOR
18	BLACK METAL

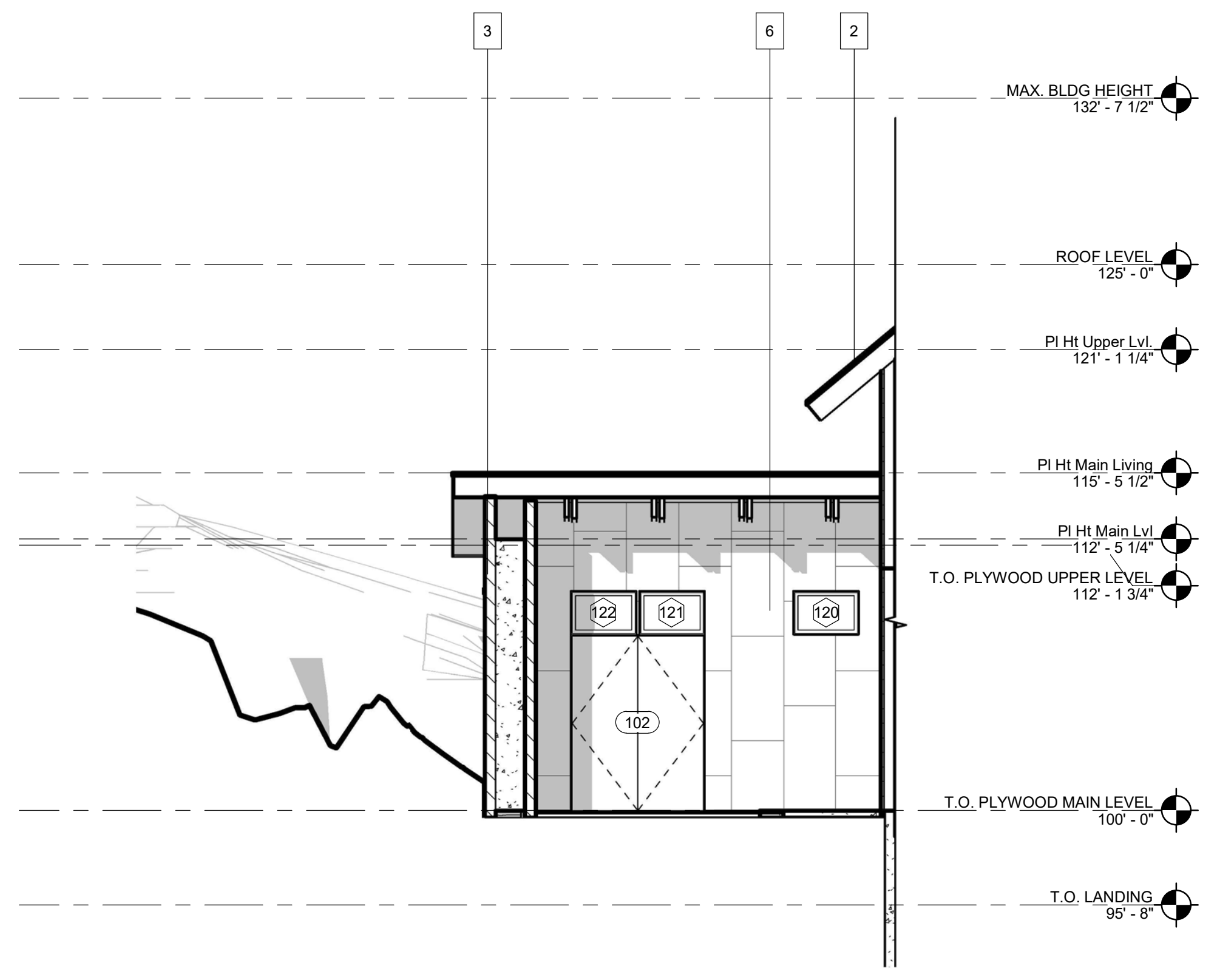

② PARTIAL WEST ELEVATION  
3/16" = 1'-0"

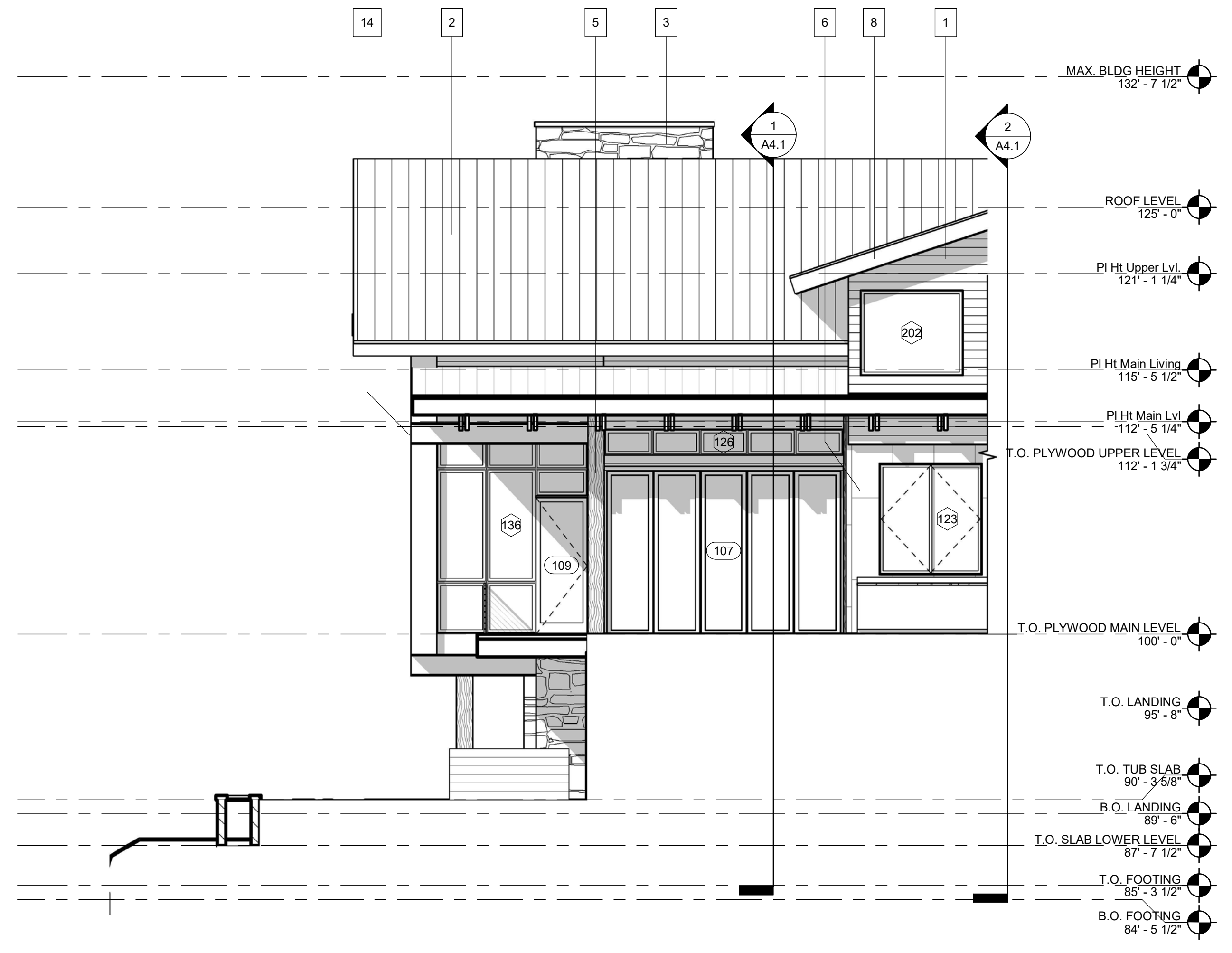

① PARTIAL EAST ELEVATION  
3/16" = 1'-0"

HARRIS RESIDENCE  
6 TUNNEL LANE, UNIT 17  
MOUNTAIN VILLAGE, CO 81435  
2041

ISSUE NAME	DATE
1 100% SD	12/18/20
2 DRB INITIAL REVIEW	12/18/20

DRAWING TITLE  
EXTERIOR ELEVATIONS - PARTIAL

SHEET NO.  
A3.3

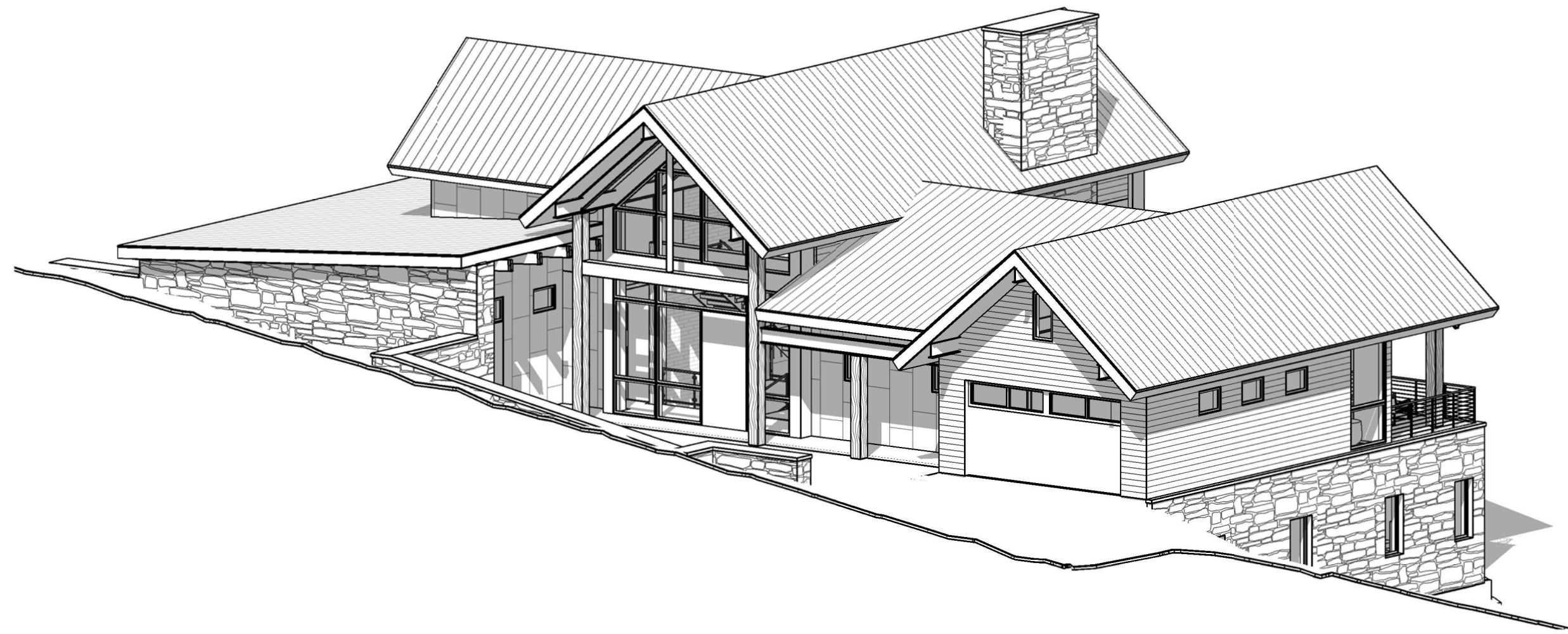

① 3D View 1

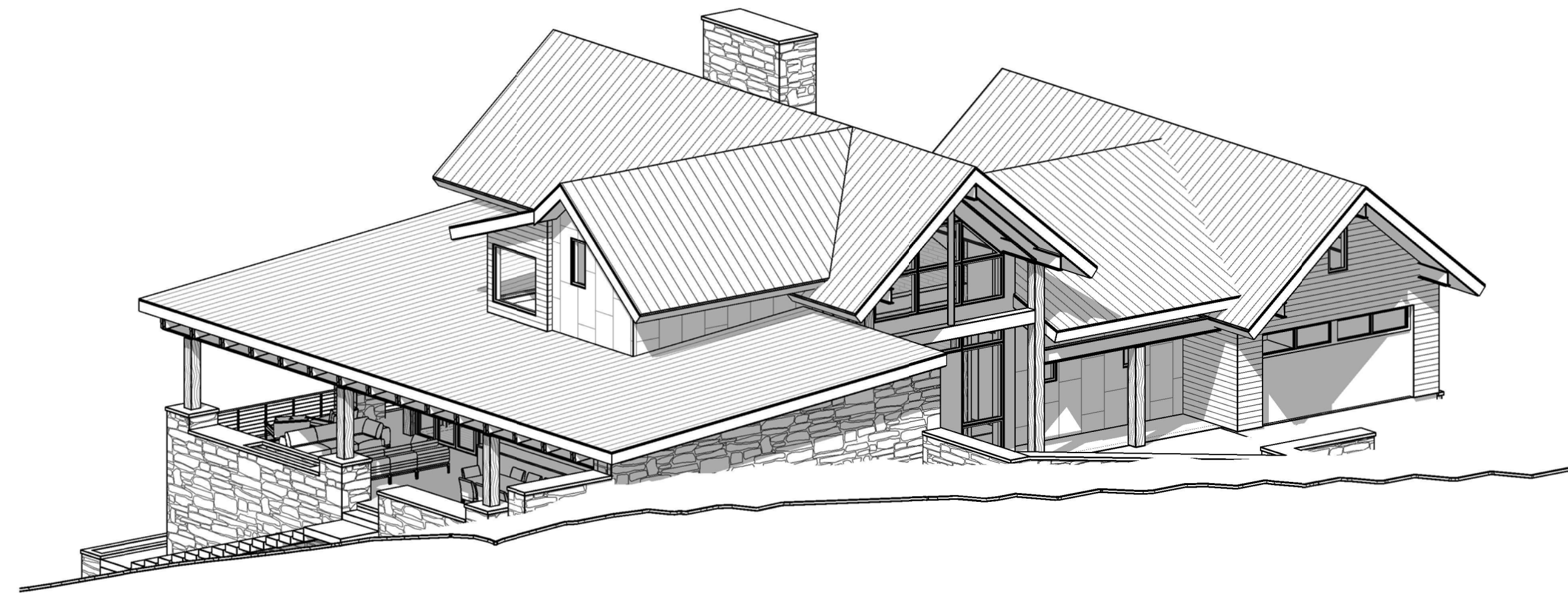

② 3D View 2

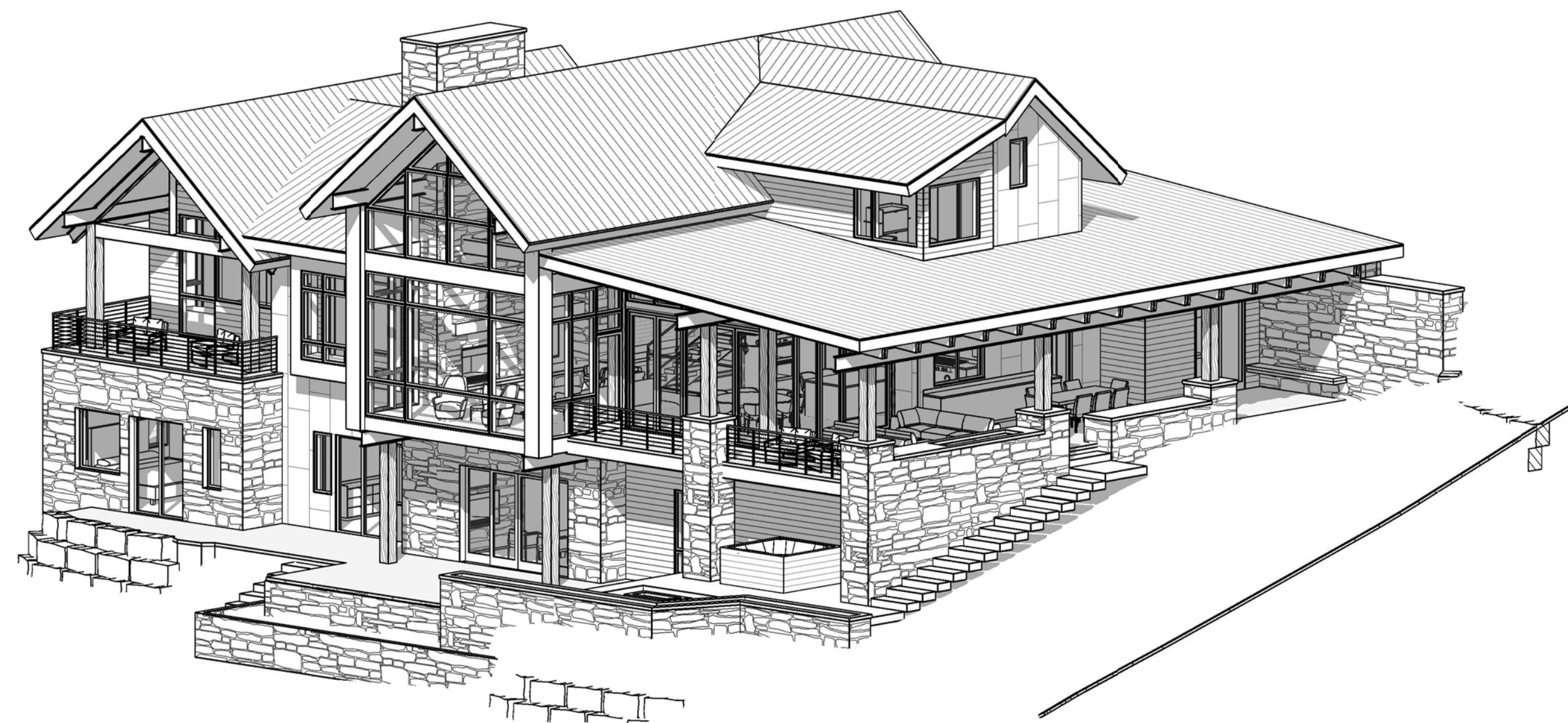

③ 3D View 3

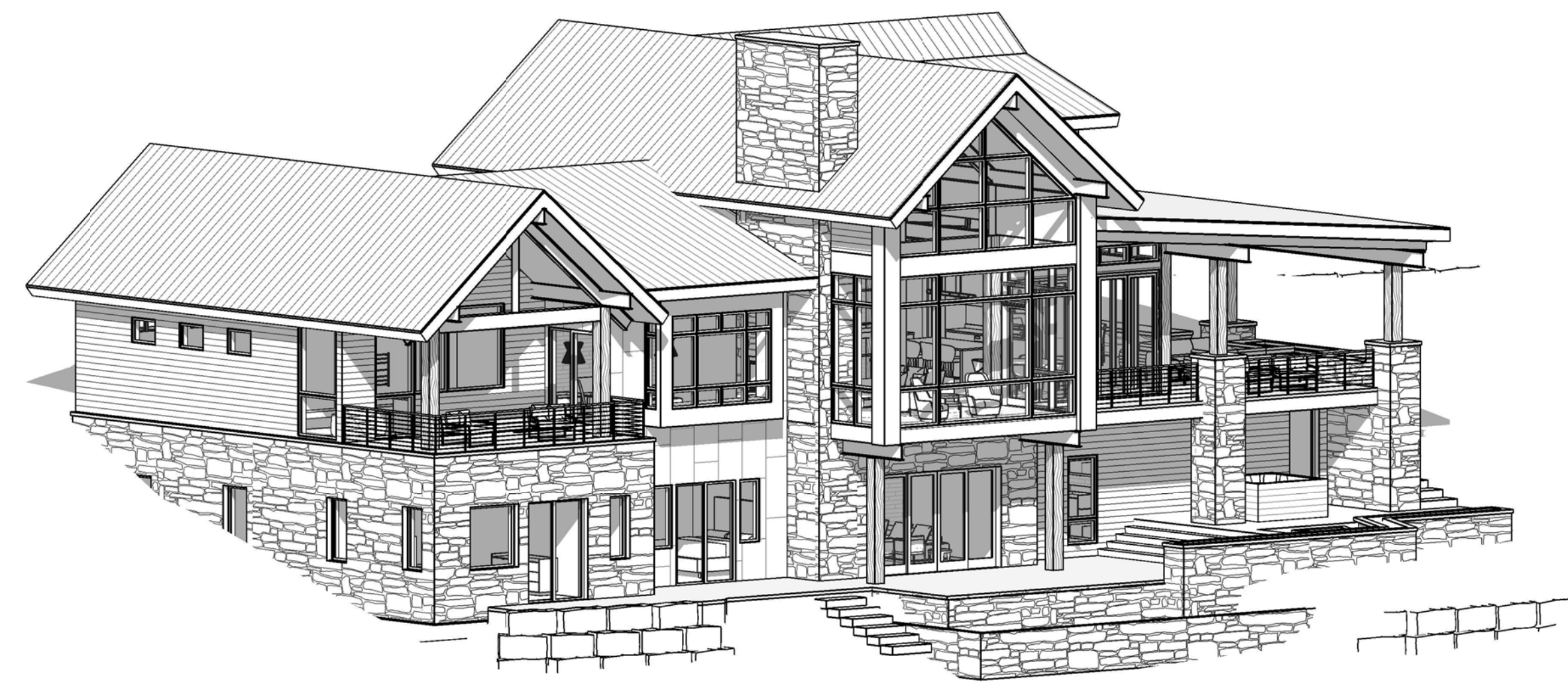

④ 3D View 4



**VERTICAL  
ARTS**  
ARCHITECTURE  
PLANNING  
LANDSCAPE  
INTERIORS

Copyright VERTICAL ARTS, INC.  
All Rights Reserved  
This document, and the ideas and designs  
incorporated herein, are an instrument of  
professional service, is the property of Vertical  
Arts Inc. and is not to be used, in whole or in part,  
for any other project without the written  
authorization from a principal of Vertical Arts, Inc.

**HARRIS RESIDENCE**  
**6 TUNNEL LANE, UNIT 17**  
**MOUNTAIN VILLAGE, CO 81435**  
**2041**

ISSUE NAME	DATE
1 100% SD	12/18/20
2 DRB INITIAL REVIEW	12/18/20

DRAWING TITLE

PERSPECTIVES

SHEET NO.

**A3.4**

12/18/2020 3:21:14 PM









ARCHITECTURE  
PLANNING  
LANDSCAPE  
INTERIORS

Copyright VERTICAL ARTS, INC.  
All Rights Reserved.  
This document, and the ideas and designs incorporated herein, are an instrument of professional service, is the property of Vertical Arts Inc. and is not to be used, in whole or in part, for any other project without the written authorization from a principal of Vertical Arts, Inc.

HARRIS RESIDENCE  
6 TUNNEL LANE, UNIT 17  
MOUNTAIN VILLAGE, CO 81435  
2041



1 SECTION LONGITUDINAL 1  
1/4" = 1'-0"

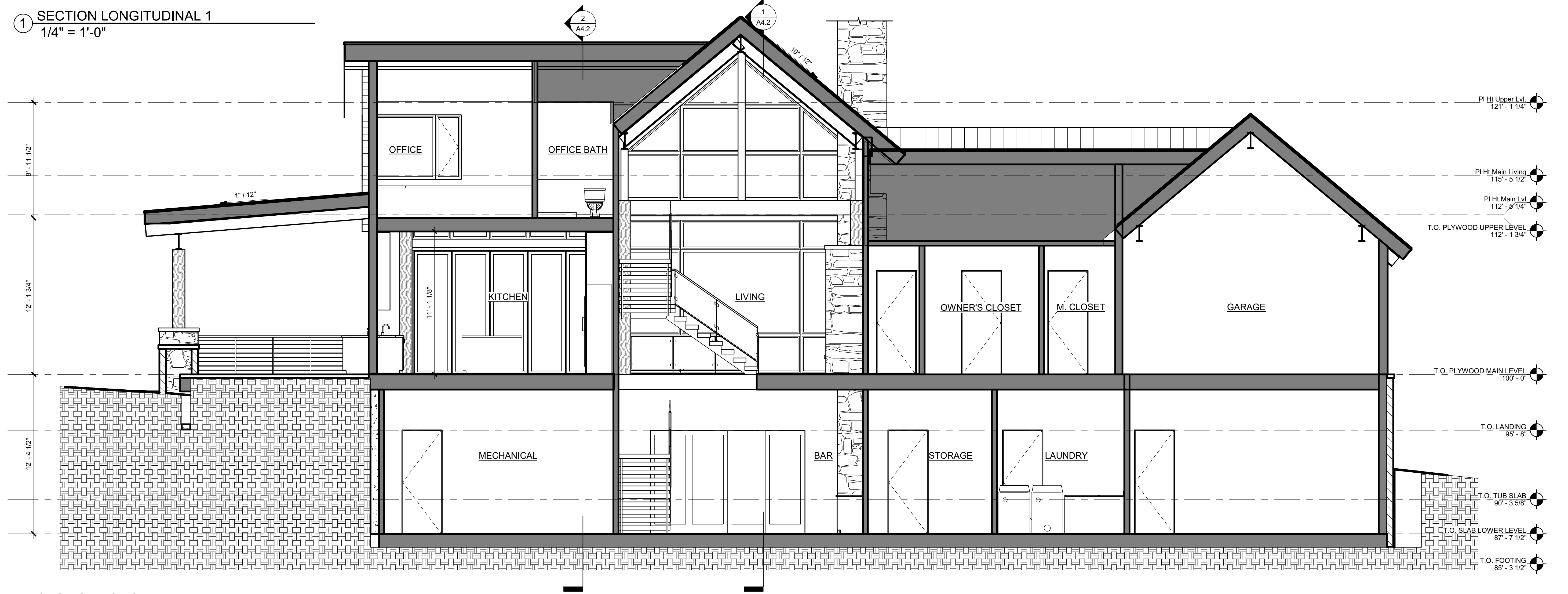

2 SECTION LONGITUDINAL 2  
1/4" = 1'-0"

ISSUE NAME	DATE
1 100% SD	12/18/20
2 DRB INITIAL REVIEW	12/18/20

DRAWING TITLE  
BUILDING SECTIONS

SHEET NO.  
A4.1

12/18/2020 3:21:19 PM



**VERTICAL  
ARTS**  
ARCHITECTURE  
PLANNING  
LANDSCAPE  
INTERIORS

Copyright VERTICAL ARTS, INC.  
All Rights Reserved  
This document, and the ideas and designs incorporated herein, are an instrument of professional service, is the property of Vertical Arts Inc. and is not to be used, in whole or in part, for any other project without the written authorization from a principal of Vertical Arts, Inc.

**HARRIS RESIDENCE**  
6 TUNNEL LANE, UNIT 17  
MOUNTAIN VILLAGE, CO 81435  
2041

ISSUE NAME	DATE
1 100% SD	12/18/20
2 DRB INITIAL REVIEW	12/18/20

DRAWING TITLE

BUILDING SECTIONS

SHEET NO.

**A4.2**

12/18/2020 3:21:21 PM

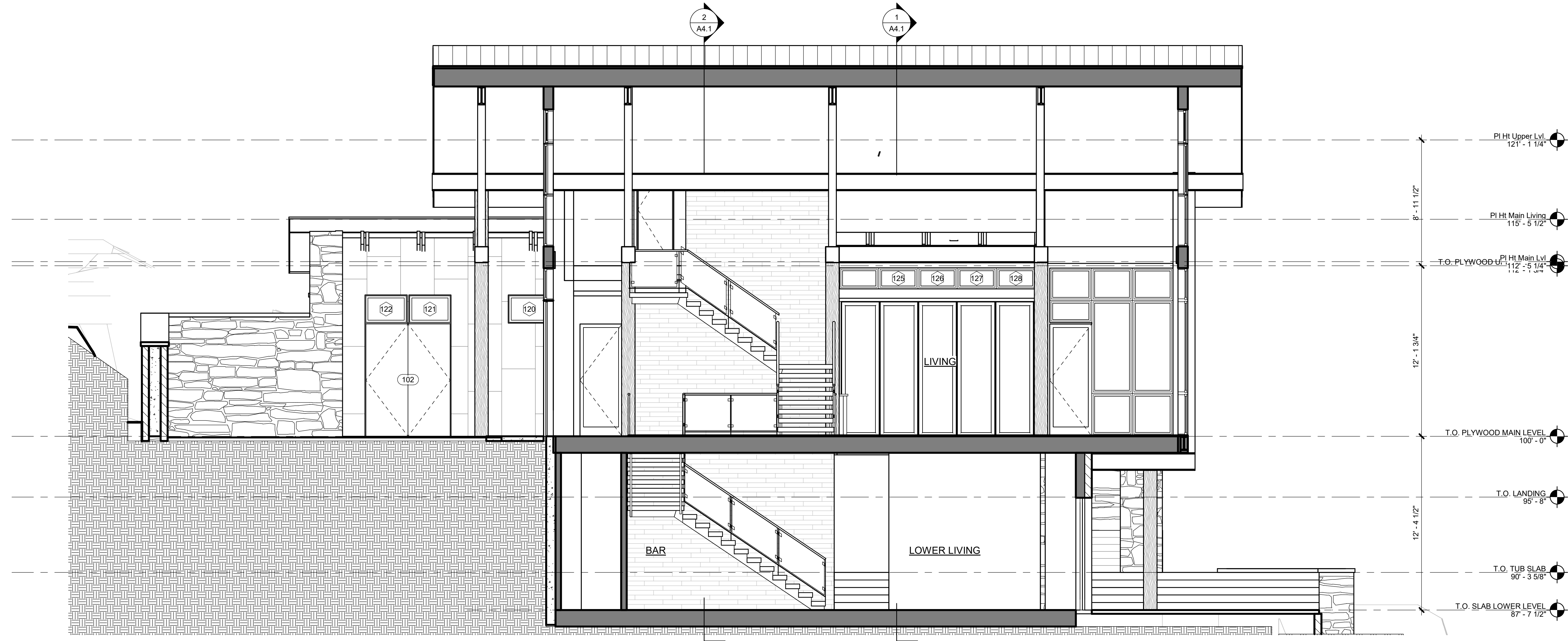

① SECTION TRAVERSE 1  
1/4" = 1'-0"

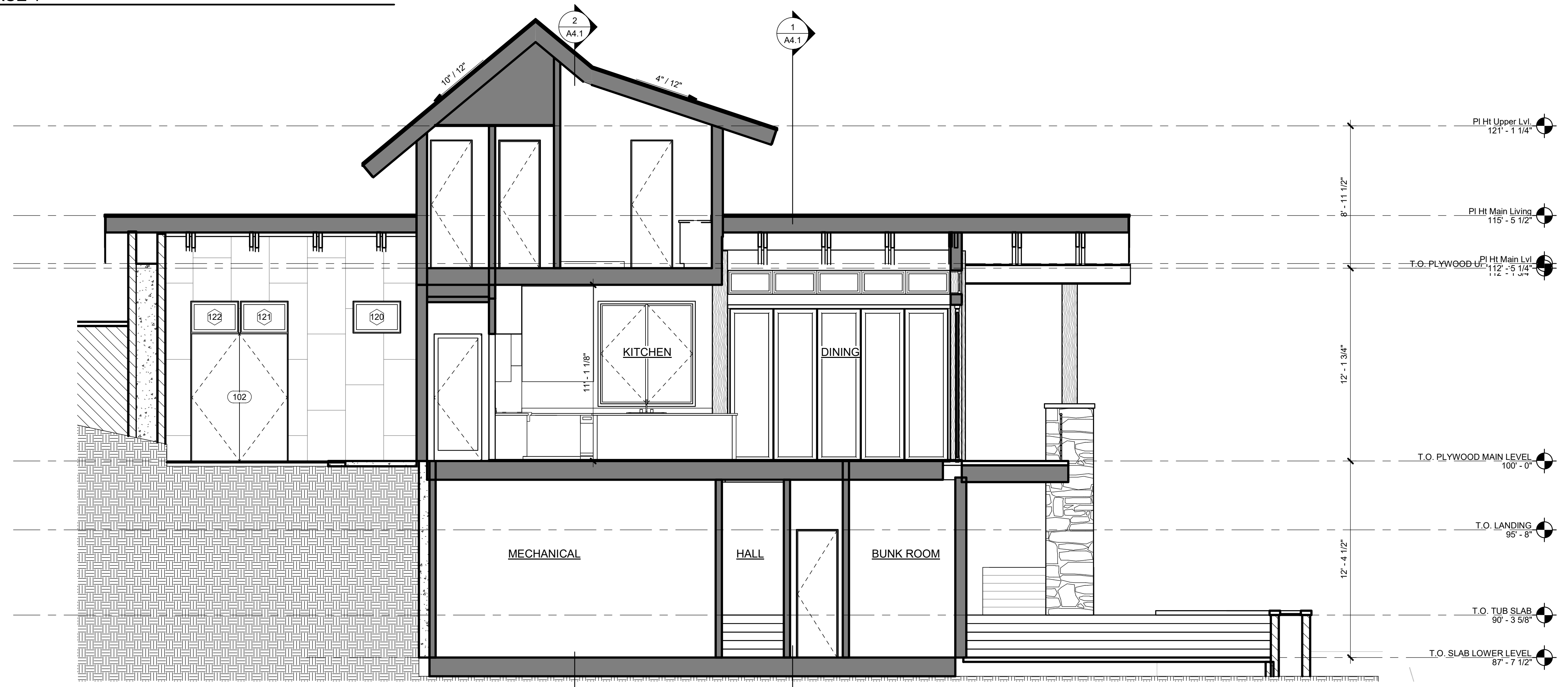

② SECTION TRAVERSE 2  
1/4" = 1'-0"

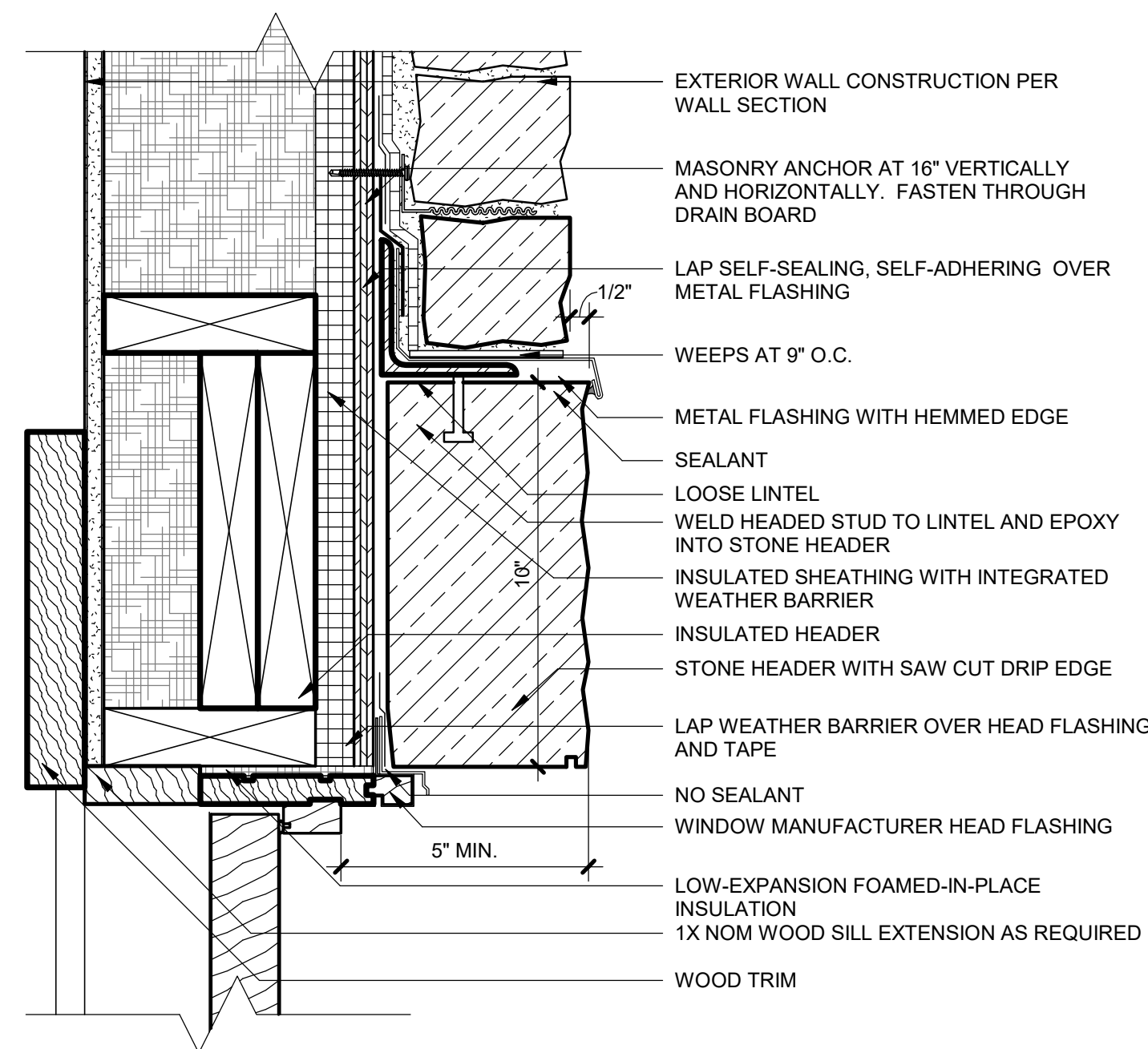

**12** EXT. DOOR HEAD STONE VENEER  
3" = 1'-0"

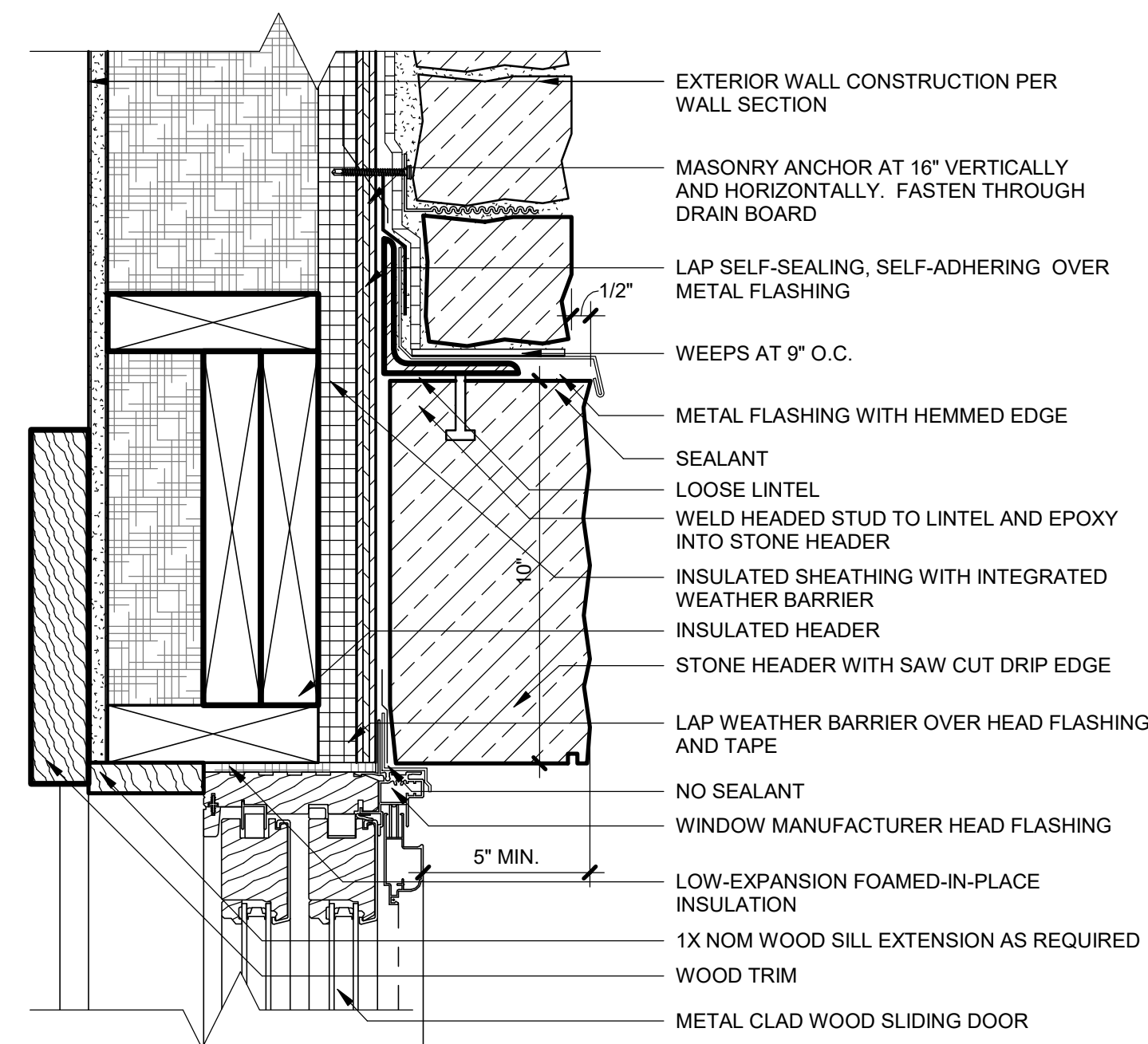

**9** SLIDING DOOR HEAD STONE VENEER  
3" = 1'-0"

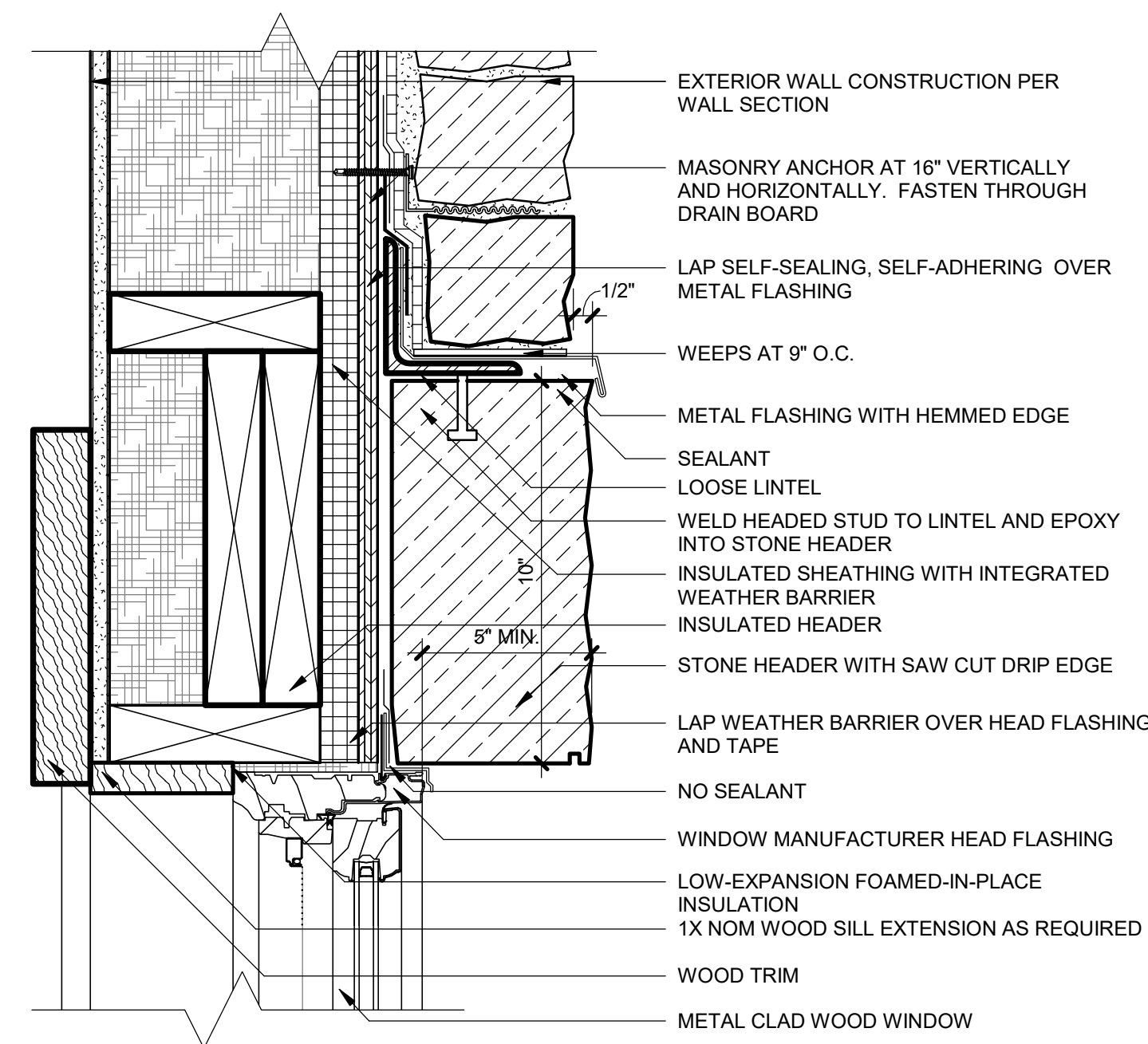

**6** WINDOW HEAD STONE VENEER  
3" = 1'-0"

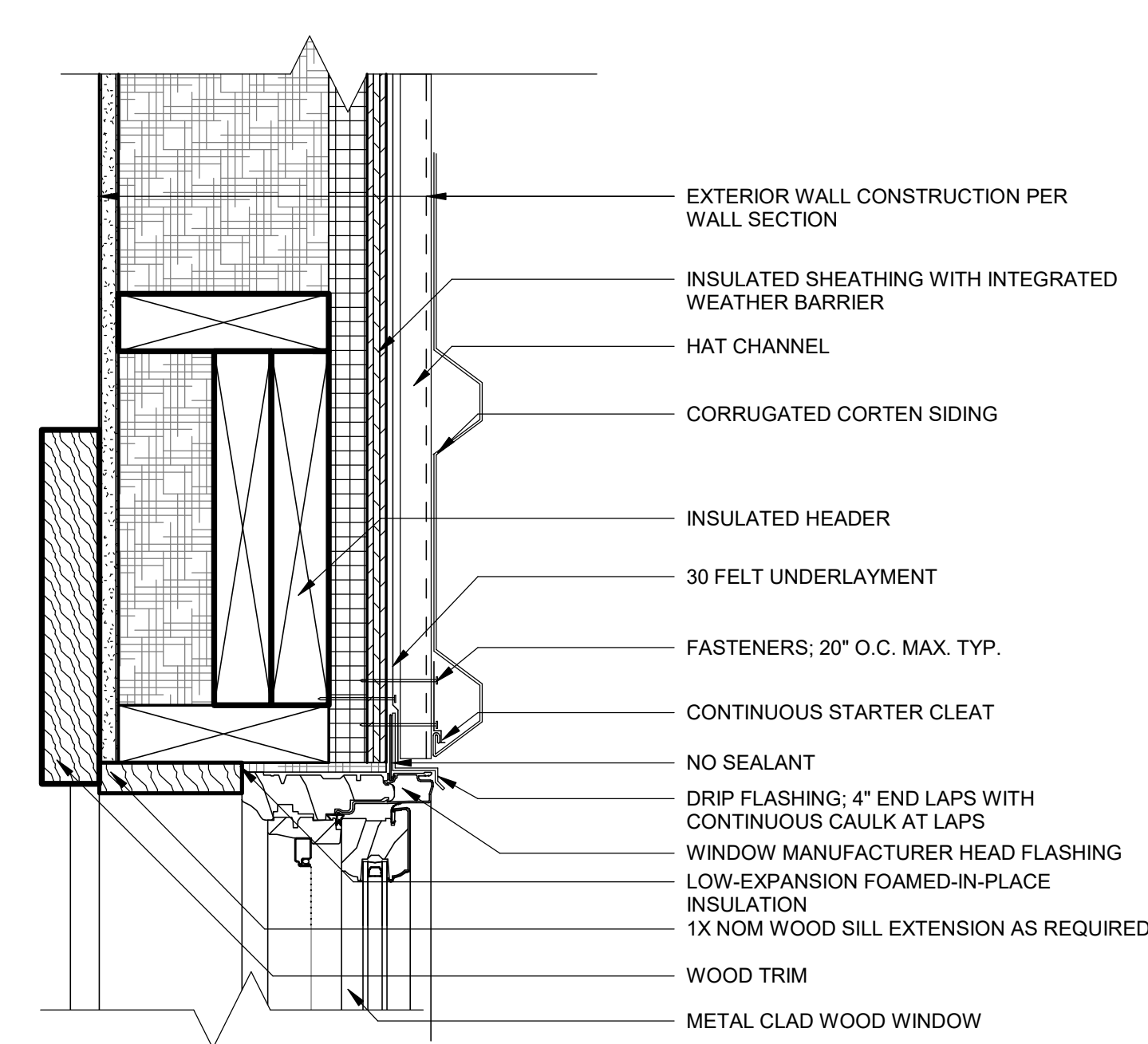

**3** WINDOW HEAD CORTEN SIDING  
3" = 1'-0"

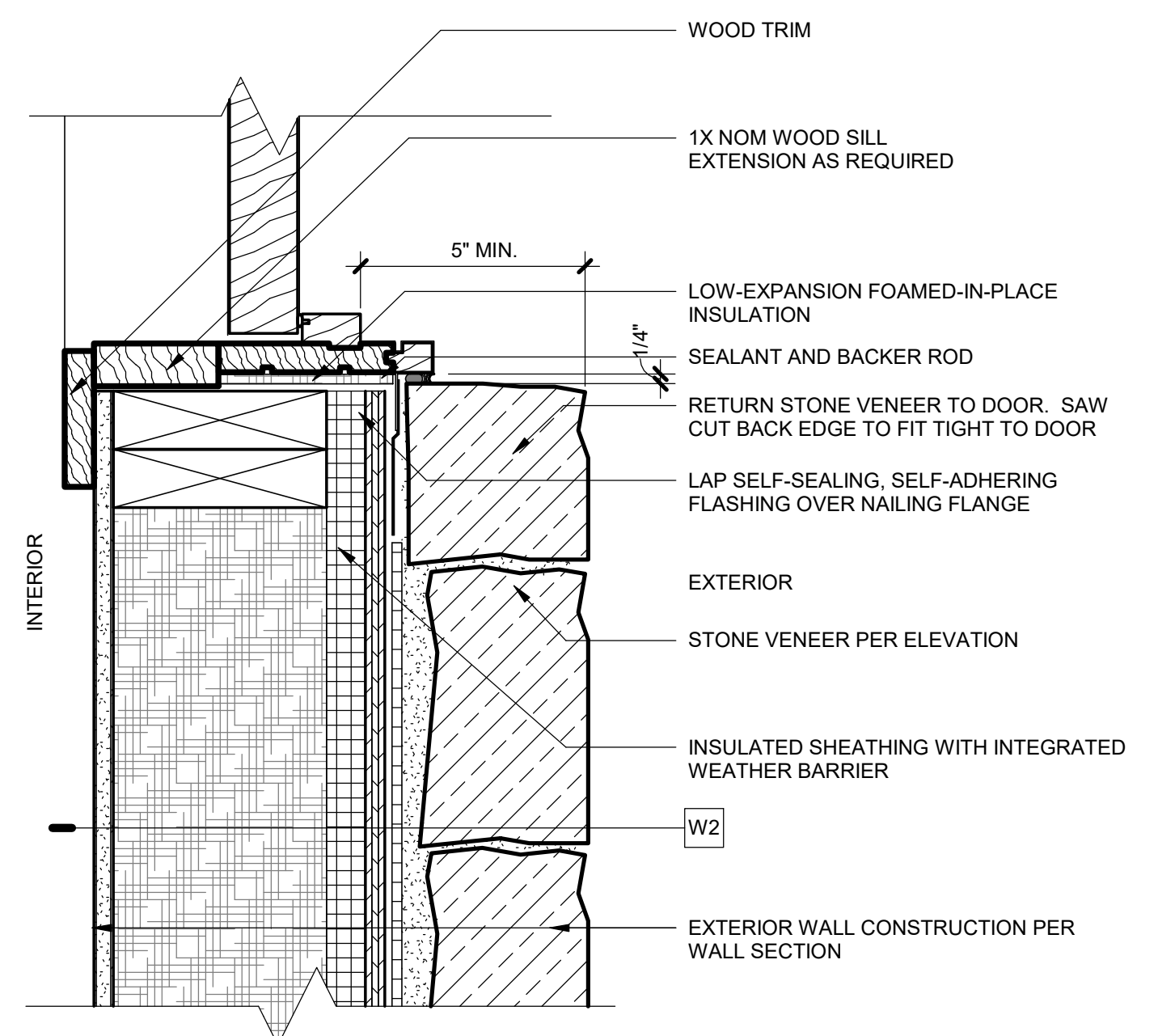

**11** EXT. DOOR JAMB STONE VENEER  
3" = 1'-0"

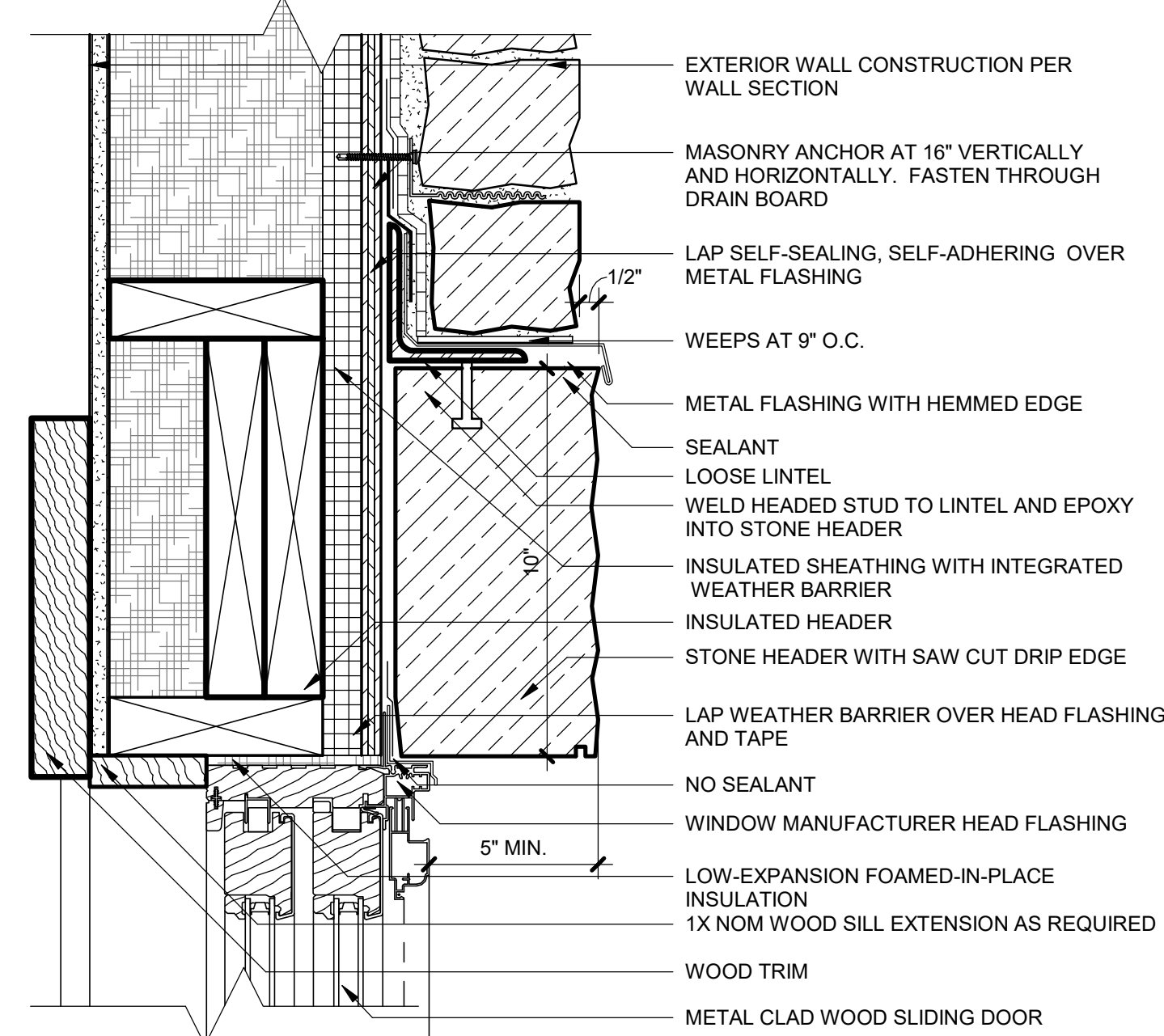

**8** SLIDING DOOR JAMB STONE VENEER  
3" = 1'-0"

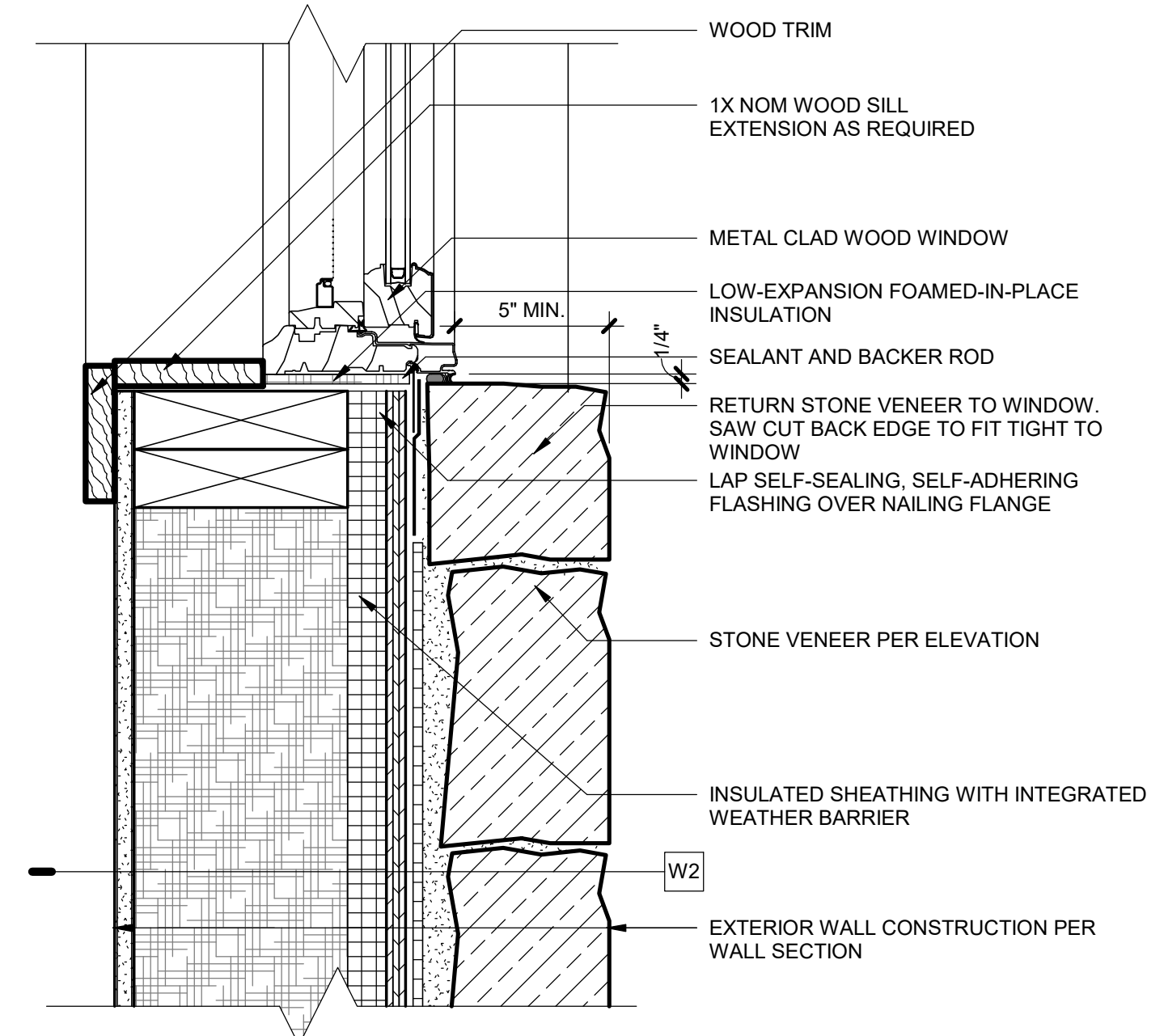

**5** WINDOW JAMB STONE VENEER  
3" = 1'-0"

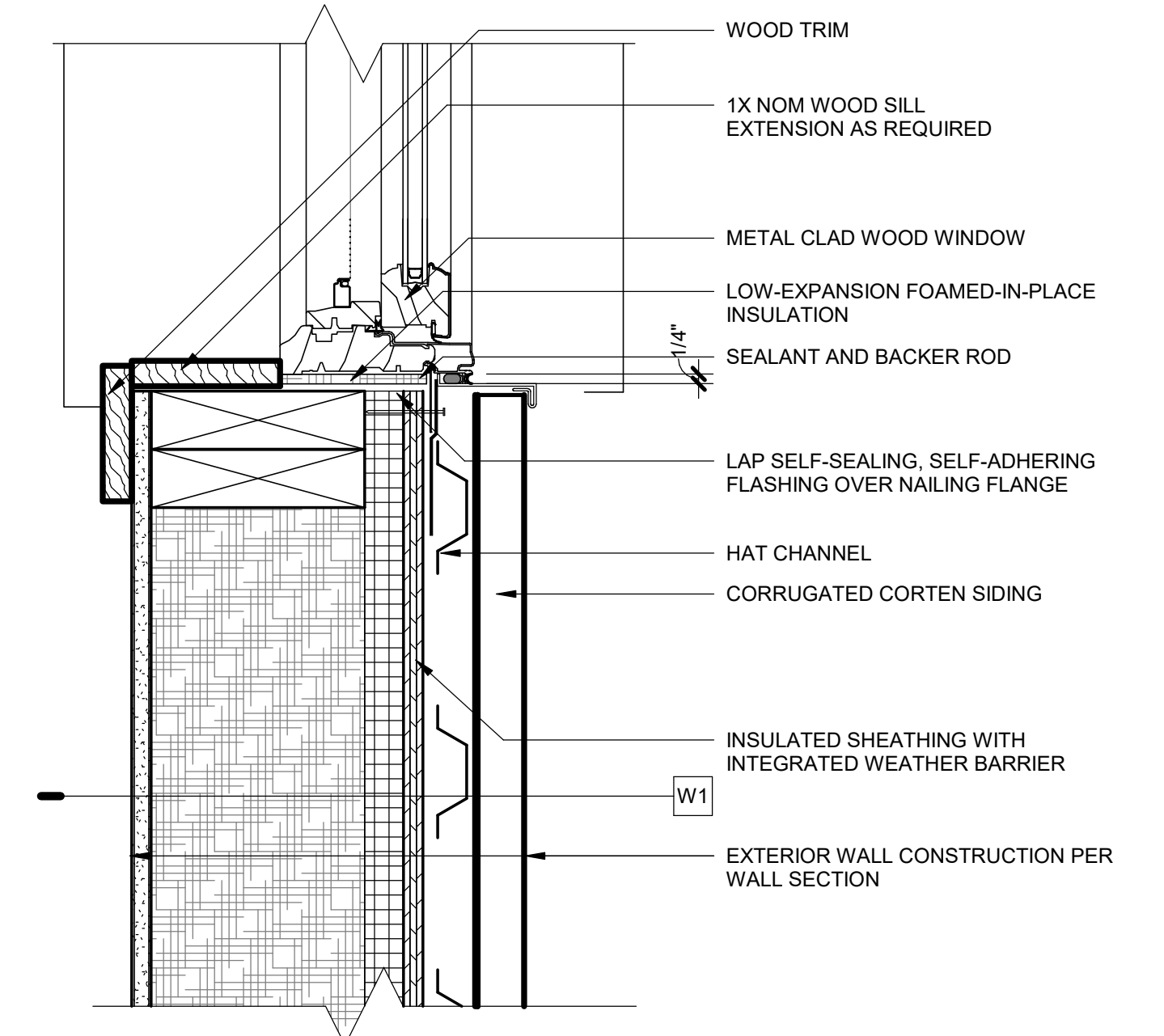

**2** WINDOW JAMB CORTEN SIDING  
3" = 1'-0"

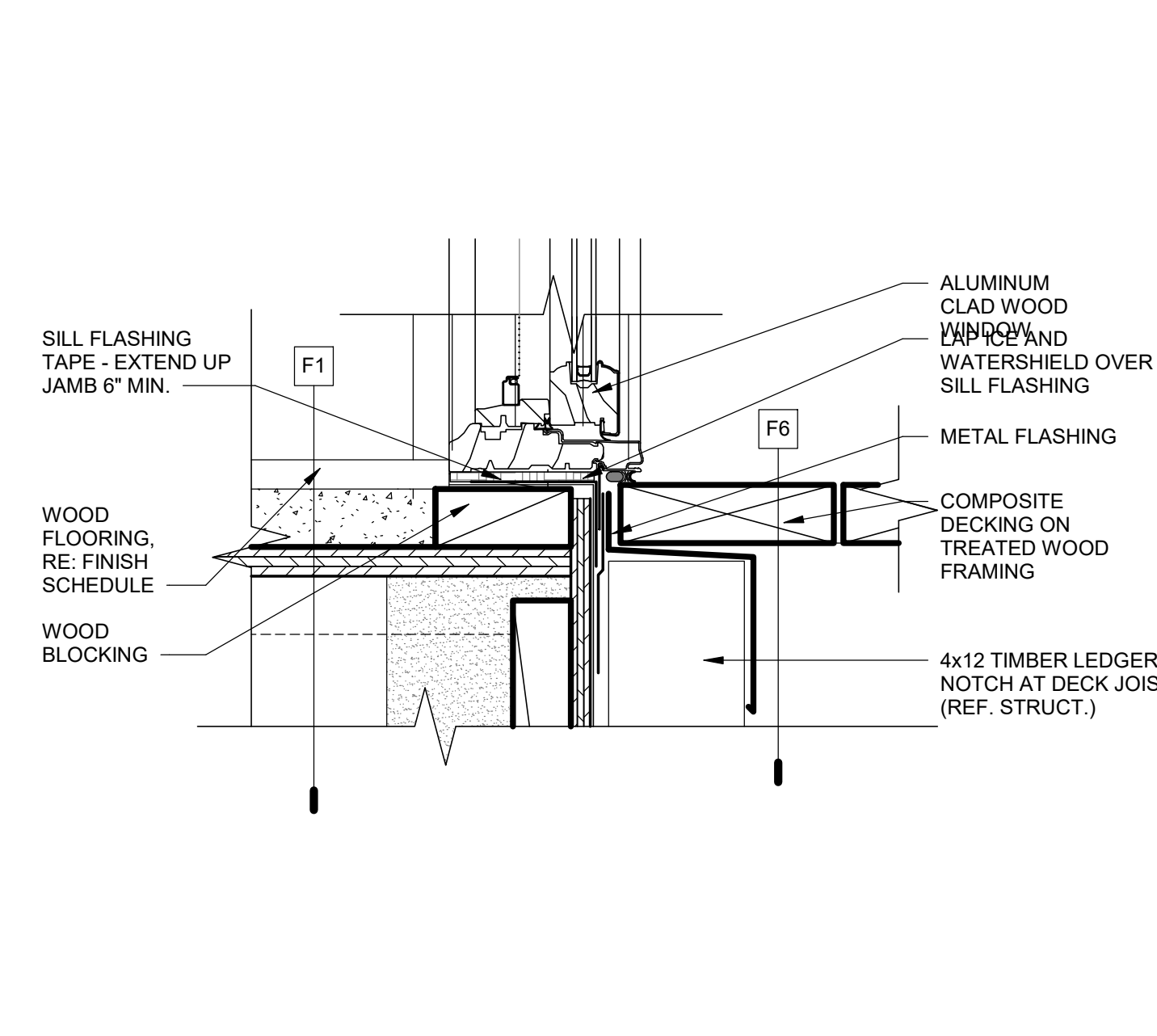

**10** WINDOW SILL @ DECK  
3" = 1'-0"

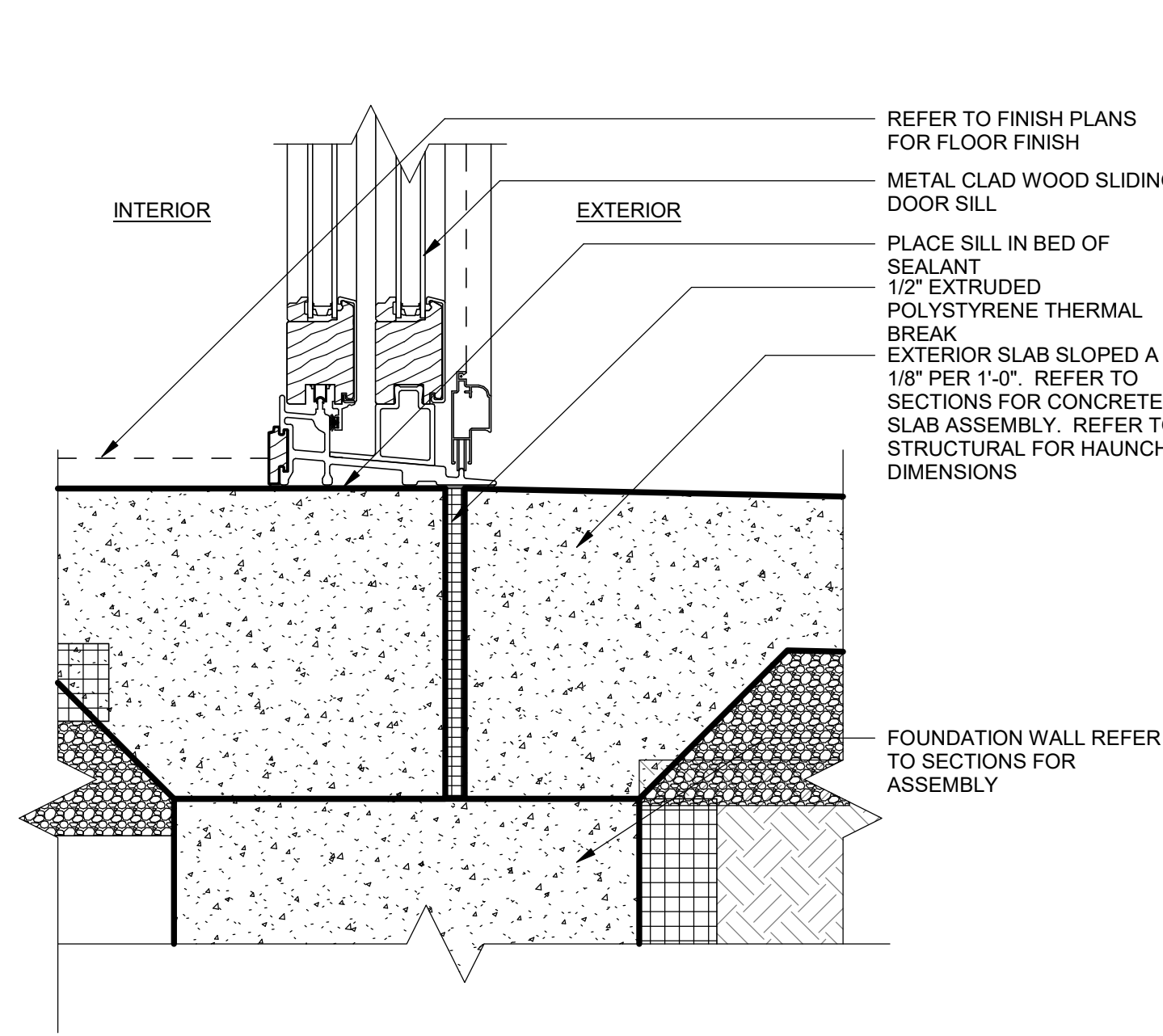

**7** SLIDING DOOR SILL STONE VENEER  
3" = 1'-0"

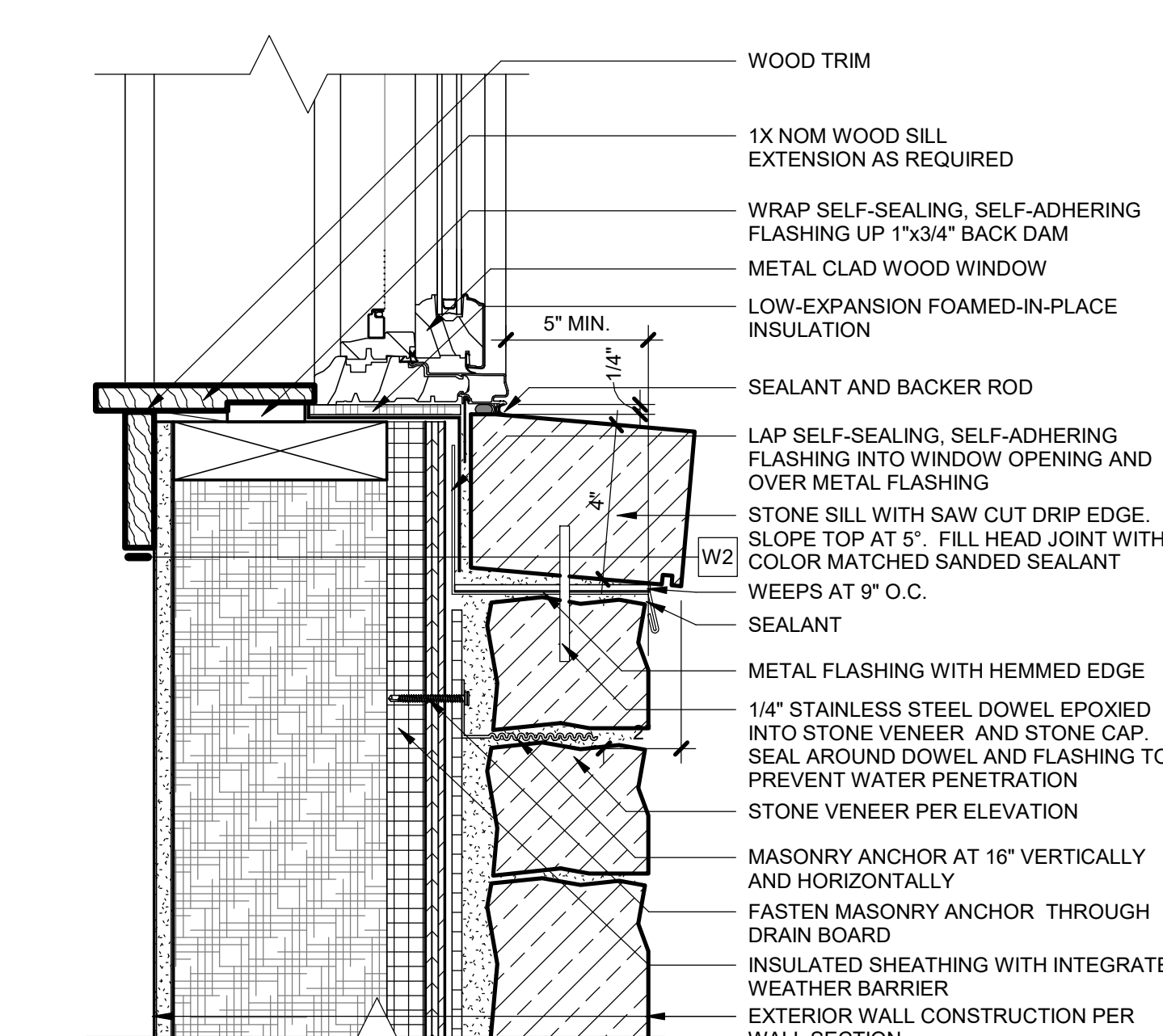

**4** WINDOW SILL STONE VENEER  
3" = 1'-0"

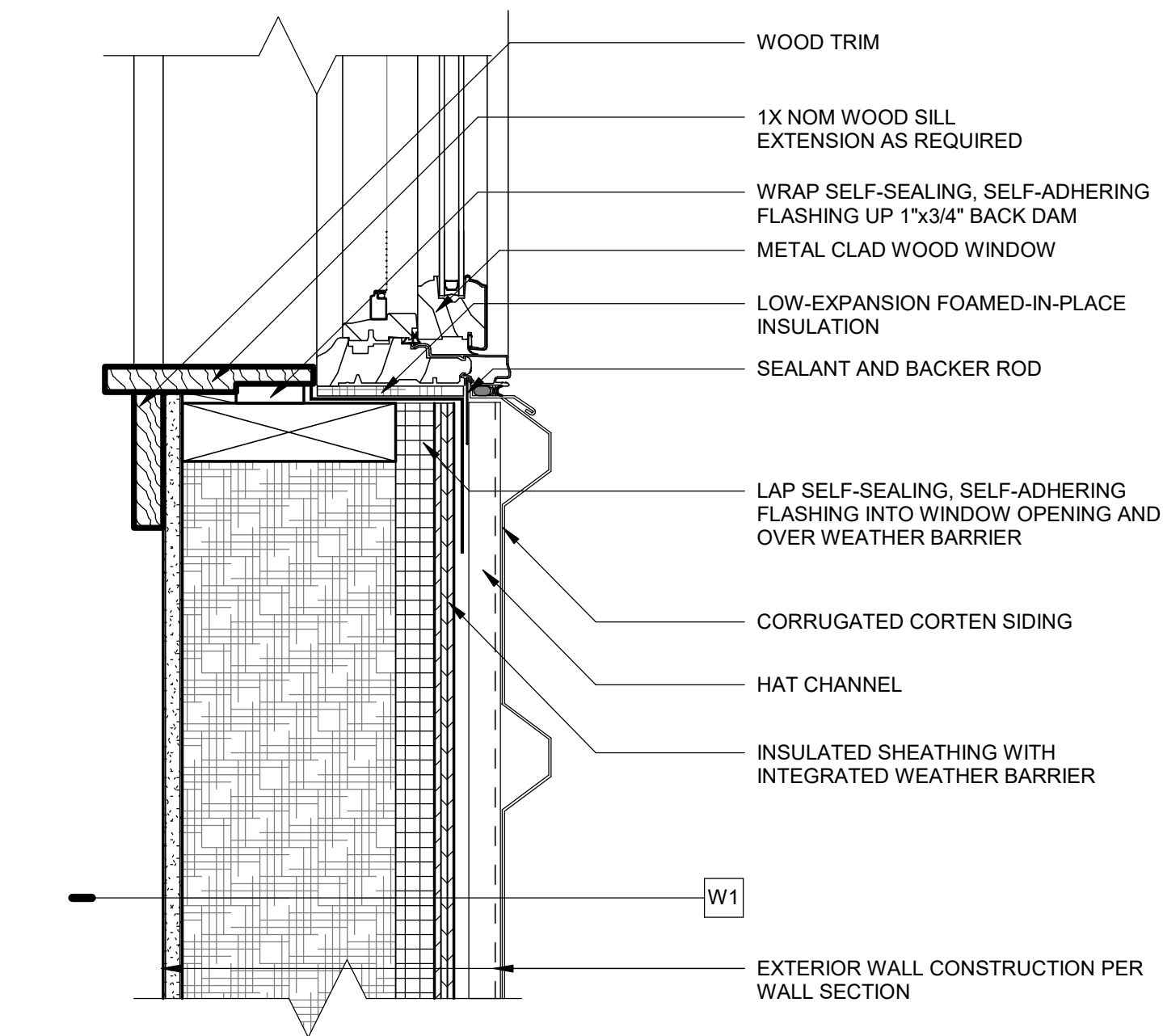

**1** WINDOW SILL CORTEN SIDING  
3" = 1'-0"



ARCHITECTURE  
PLANNING  
LANDSCAPE  
INTERIORS

Copyright VERTICAL ARTS, INC.  
All Rights Reserved

This document, and the ideas and designs incorporated herein, are an instrument of professional service, is the property of Vertical Arts Inc. and is not to be used, in whole or in part, for any other project without the written authorization from a principal of Vertical Arts, Inc.

HARRIS RESIDENCE  
6 TUNNEL LANE, UNIT 17  
MOUNTAIN VILLAGE, CO 81435  
2041

ISSUE NAME	DATE
DRB INITIAL REVIEW	12/18/20

DRAWING TITLE

DETAILS

SHEET NO.

A9.1







DOOR SCHEDULE										
MARK	NOMINAL WIDTH	NOMINAL HEIGHT	THICKNESS	FINISH		DETAILS			TYPE	REMARKS
				DOOR	FRAME	HEAD	JAMB	THRESHOLD		
001	12'-0"	8'-0"	2"						312	
002	6'-0"	8'-0"	1 3/4"						229	
003	2'-6"	8'-0"	2"						29	
004	2'-6"	8'-0"	2"						29	
005	2'-6"	8'-0"	2"						29	
006	3'-0"	8'-0"	2"						20	
007	3'-0"	8'-0"	2"						20	
008	2'-6"	8'-0"	2"						29	
009	3'-0"	8'-0"	2"						20	
010	6'-0"	8'-0"	1 3/4"						229	
014	3'-0"	8'-0"	2"						20	
015	3'-0"	8'-0"	2"						20	
016	3'-0"	8'-0"	2"						20	
018	3'-0"	8'-0"	2"						20	
019	3'-0"	8'-0"	2"						20	
020	2'-6"	8'-0"	2"						29	
021	2'-6"	8'-0"	2"						29	
022	3'-0"	8'-0"	2"						9	
023	2'-6"	8'-0"	2"						29	
024	2'-6"	8'-0"	2"						29	
101	4'-6"	9'-7 1/4"	2"						71	
102	6'-0"	8'-0"	2"						202	
103	2'-6"	8'-0"	2"						29	
104	3'-0"	8'-0"	2"						20	
105	6'-0"	8'-0"	2"						195	
106	3'-0"	8'-0"	2"						9	
107	14'-0"	9'-10"	2 5/8"						66	Folding Glass Door
108	15'-0"	9'-10"	2 5/8"						47	Folding Glass Door
109	3'-0"	8'-0"	2"						9	
110	3'-0"	8'-0"	2"						9	
111	2'-6"	8'-0"	2"						29	
112	2'-6"	7'-0"	4						4	Shower Enclosure
113	16'-0"	8'-0"							68	Overhead Garage Door
115	3'-0"	8'-0"	2"						20	
116	3'-0"	8'-0"	2"						20	
117	3'-0"	8'-0"	2"						20	
118	3'-0"	8'-0"	2"						20	
119	2'-6"	8'-0"	2"						29	
127	2'-6"	8'-0"	2"						29	
130	2'-6"	8'-0"	2"						29	
136	2'-6"	8'-0"	2"						29	
140	2'-6"	8'-0"	2"						29	
150	2'-6"	8'-0"	2"						29	
201	2'-6"	8'-0"	2"						29	

NOTE:  
 -Provide Tempered glazing as required per the I.R.C.  
 -Windows to have maximum U-factor of .35  
 -Windows and sliding glass doors shall have an air infiltration rate of no more than .3 CFM per square foot and swinging doors no more than .5 CFM per square foot.

WINDOW SCHEDULE											
Mark	NOMINAL WIDTH	NOMINAL HEIGHT	HEAD HT.	DETAILS			TYPE	MATERIAL	TEMPERED	OPERATION	REMARKS
				HEAD	JAMB	SILL					
001	3'-0"	5'-0"	8'-0"					Steel		Casement	
002	3'-0"	2'-0"	3'-0"					Steel		Fixed	
003	2'-0"	5'-0"	8'-0"					Steel		Casement	
004	2'-0"	5'-0"	8'-0"					Steel		Casement	
005	2'-0"	5'-0"	8'-0"					Steel		Fixed	
006	5'-0"	5'-0"	8'-0"					Steel		Fixed	
007	2'-6"	5'-0"	8'-0"					Steel		Casement	
008	2'-6"	5'-0"	8'-0"					Steel		Casement	
009	3'-0"	8'-0"	8'-0"					Steel		Fixed	
010	3'-0"	2'-0"	8'-0"					Steel		Awning	
101	4'-4 3/4"	3'-0"	15'-5 1/4"					Steel		Fixed	
102	4'-8"	3'-0"	15'-5 1/4"					Steel		Fixed	
103	4'-4 3/4"	3'-0"	3'-0 3/4"					Steel		Fixed	
104	4'-4 3/4"	6'-7 1/2"	9'-8 1/4"					Steel		Fixed	
105	4'-8"	6'-7 1/2"	9'-8 1/4"					Steel		Fixed	
106	4'-4 3/4"	6'-7 1/2"	9'-8 1/4"					Steel		Fixed	
107	4'-4 3/4"	2'-3 1/2"	11'-11 3/4"					Steel		Fixed	
108	9'-4"	2'-3 1/2"	11'-11 3/4"					Steel		Fixed	
109	4'-4 3/4"	2'-3 1/2"	11'-11 3/4"					Steel		Fixed	
110	4'-4 3/4"	3'-8"	5'-0 1/2"					Steel		Fixed	
111	4'-8"	3'-8"	5'-0 1/2"					Steel		Fixed	
112	4'-8"	3'-8"	5'-0 1/2"					Steel		Fixed	
113	4'-4 3/4"	3'-8"	5'-0 1/2"					Steel		Fixed	
114	4'-4 3/4"	3'-8"	8'-8 1/2"					Steel		Fixed	
115	4'-8"	3'-8"	8'-8 1/2"					Steel		Fixed	
116	4'-8"	3'-8"	8'-8 1/2"					Steel		Fixed	
117	4'-4 3/4"	3'-8"	8'-8 1/2"					Steel		Fixed	
118	4'-8"	3'-8"	12'-4 1/2"					Steel		Fixed	
119	4'-8"	3'-8"	12'-4 1/2"					Steel		Fixed	
120	3'-0"	2'-0"	10'-0 3/4"					Steel		Fixed	
121	3'-0"	2'-0"	10'-0 3/4"					Steel		Fixed	
122	3'-0"	2'-0"	10'-0 3/4"					Steel		Fixed	
123	6'-0"	6'-6"	10'-0"					Steel		Horizontal Slider	
124	2'-9 1/2"	1'-6"	12'-0"					Steel		Fixed	
125	2'-9 1/2"	1'-6"	12'-0"					Steel		Fixed	
126	2'-9 1/2"	1'-6"	12'-0"					Steel		Fixed	
127	2'-9 1/2"	1'-6"	12'-0"					Steel		Fixed	
128	2'-9 1/2"	1'-6"	12'-0"					Steel		Fixed	
129	3'-0"	1'-6"	12'-0"					Steel		Fixed	
130	3'-0"	1'-6"	12'-0"					Steel		Fixed	
131	3'-0"	1'-6"	12'-0"					Steel		Fixed	
132	3'-0"	1'-6"	12'-0"					Steel		Fixed	
133	3'-0"	1'-6"	12'-0"					Steel		Fixed	
134	2'-10 3/4"	3'-0"	3'-0 3/4"					Steel		Fixed	
135	2'-10 3/4"	3'-0"	3'-0 3/4"					Steel		Fixed	
136	2'-10 3/4"	6'-7 1/2"	9'-8 1/4"					Steel		Fixed	
137	2'-10 3/4"	6'-7 1/2"	9'-8 1/4"					Steel		Fixed	
138	3'-0"	1'-7"	9'-8 1/4"					Steel		Fixed	
139	3'-0"	2'-3 1/2"	11'-11 3/4"					Steel		Fixed	
140	2'-10 3/4"	2'-3 1/2"	11'-11 3/4"					Steel		Fixed	
141	2'-10 3/4"	2'-3 1/2"	11'-11 3/4"					Steel		Fixed	
142	4'-4 3/4"	3'-0"	15'-5 1/4"					Steel		Fixed	
143	9'-4"	3'-0"	15'-5 1/4"					Steel		Fixed	
144	4'-4 3/4"	3'-0"	3'-0 3/4"					Steel		Fixed	
145	4'-4 3/4"	6'-7 1/2"	9'-8 1/4"					Steel		Fixed	
146	9'-4"	6'-7 1/2"	9'-8 1/4"					Steel		Fixed	
147	4'-4 3/4"	6'-7 1/2"	9'-8 1/4"					Steel		Fixed	
148	4'-4 3/4"	2'-3 1/2"	11'-11 3/4"					Steel		Fixed	
149	9'-4"	2'-3 1/2"	11'-11 3/4"					Steel		Fixed	
150	4'-4 3/4"	2'-3 1/2"	11'-11 3/4"					Steel		Fixed	
151	4'-4 3/4"	3'-8"	5'-0 1/2"					Steel		Fixed	
152	4'-8"	3'-8"	5'-0 1/2"					Steel		Fixed	
153	4'-8"	3'-8"	5'-0 1/2"					Steel		Fixed	
154	4'-4 3/4"	3'-8"	5'-0 1/2"					Steel		Fixed	
155	4'-4 3/4"	3'-8"	8'-8 1/2"					Steel		Fixed	
156	4'-8"	3'-8"	8'-8 1/2"					Steel		Fixed	
157	4'-8"	3'-8"	8'-8 1/2"					Steel		Fixed	
158	4'-4 3/4"	3'-8"	8'-8 1/2"					Steel		Fixed	
159	4'-8"	3'-8"	12'-4 1/2"					Steel		Fixed	
160	4'-8"	3'-8"	12'-4 1/2"					Steel		Fixed	
161	2'-10 3/4"	3'-0"	3'-0 3/4"					Steel		Fixed	
162	2'-10 3/4"	3'-0"	3'-0 3/4"					Steel		Fixed	
163	2'-10 3/4"	6'-7 1/2"	9'-8 1/4"					Steel		Fixed	
164	2'-10 3/4"	6'-7 1/2"	9'-8 1/4"					Steel		Fixed	
165	2'-10 3/4"	2'-3 1/2"	11'-11 3/4"					Steel		Fixed	
166	2'-10 3/4"	2'-3 1/2"	11'-11 3/4"					Steel		Fixed	
167	2'-6"	1'-6"	3'-4"					Steel		Fixed	
168	2'-6"	1'-6"	3'-4"					Steel		Fixed	
169	2'-6"	1'-6"	3'-4"					Steel		Fixed	
170	2'-6"	1'-6"	3'-4"					Steel		Fixed	
171	2'-6"	4'-4"	7'-8"					Steel		Casement	
172	5'-0"	4'-4"	7'-8"					Steel		Fixed	
173	2'-6"	4'-4"	7'-8"					Steel		Casement	
174	2'-6"	1'-6"	9'-2"					Steel		Fixed	
175	2'-6"	1'-6"	9'-2"					Steel		Fixed	
176	2'-6"	1'-6"	9'-2"					Steel		Fixed	
177	2'-6"	1'-6"	9'-2"					Steel		Fixed	
178	1'-4"	1'-6"	3'-4"					Steel		Fixed	
179	1'-4"	4'-4"	7'-8"					Steel		Casement	
180	1'-4"	1'-6"	9'-2"					Steel		Fixed	
181	2'-9 1/2"	8'-0"	8'-0"					Steel		Fixed	
182	4'-0"	3'-4"	3'-5"					Steel		Fixed	
183	5'-8"	5'-0"	8'-5"					Steel		Fixed	
184	3'-4"	5'-0"	8'-5"					Steel		Fixed	
185	4'-0"	5'-0"	8'-5"					Steel		Casement	
186	5'-8"	1'-8"	10'-1"					Steel		Fixed	
187	3'-4"	1'-8"	10'-1"					Steel		Fixed	
188	4'-0"	1'-8"	10'-1"					Steel		Fixed	
189	2'-0"	3'-0"	15'-0"					Steel		Fixed	
190	4'-10"	3'-4"	3'-8"					Steel		Fixed	
191	4'-10"	5'-6"	9'-0"					Steel		Fixed	
192	3'-0"	2'-0"	8'-0"					Steel		Awning	
193	3'-0"	2'-0"	8'-0"					Steel		Awning	
194	3'-0"	2'-0"	8'-0"					Steel		Awning	
195	2'-0"	4'-0"	4'-0"					Steel		Fixed	
196	2'-0"	3'-0"	8'-0"					Steel		Fixed	
197	2'-0"	3'-0"	8'-0"					Steel		Fixed	
201	2'-0"	4'-0"	10'-6"					Steel		Casement	
202	6'-0"	5'-0"	8'-0"					Steel		Fixed	
203	5'-0"	5'-0"	8'-0"					Steel		Fixed	
204	2'-0"	5'-0"	8'-0"					Steel		Casement	



ARCHITECTURE  
 PLANNING  
 LANDSCAPE  
 INTERIORS

Copyright VERTICAL ARTS, INC.  
 All Rights Reserved  
 This document, and the ideas and designs incorporated herein, are an instrument of professional service, the property of Vertical Arts Inc. and is not to be used, in whole or in part, for any other project without the written authorization from a principal of Vertical Arts, Inc.

## John A. Miller

---

**From:** Kaye Simonson <kayes@sanmiguelcountyco.gov>  
**Sent:** Tuesday, January 26, 2021 11:55 AM  
**To:** John A. Miller  
**Cc:** Ron Quarles; Amy Markwell; kgeiger@telluride-co.gov; Michelle Haynes; Amy Ward; pwisor; chris@alpineplanningllc.com  
**Subject:** Re: Unit 17 - Ridge Club, Courtesy Referral

John,

San Miguel County has no objections to the request to waive story poles for the proposed project at Unit 17 - The Ridge. The proposed maximum roof elevation is approximately 10,480', while the ridge elevation is about 10,575. The site is not visible from any locations identified in the Settlement Agreement. If you have any questions, please let me know. Thanks.

Kaye

On Mon, Jan 25, 2021 at 7:07 PM John A. Miller <[JohnMiller@mtnvillage.org](mailto:JohnMiller@mtnvillage.org)> wrote:

Evening everyone –

I am just following up on the below email regarding Unit 17 at the ridge. Please note the deadline for comments.

Thanks and hope you're all doing well,

J

John A Miller III, CFM

Senior Planner

Planning & Development Services

Town of Mountain Village

455 Mountain Village Blvd, Suite A

Mountain Village, CO 81435

O :: 970.369.8203

C :: 970.417.1789





For information about The Town of Mountain Village's response to COVID-19 (Coronavirus), please visit [townofmountainvillage.com/coronavirus/](https://townofmountainvillage.com/coronavirus/)

---

**From:** John A. Miller

**Sent:** Thursday, January 7, 2021 3:31 PM

**To:** [kayes@sanmiguelcountyco.gov](mailto:kayes@sanmiguelcountyco.gov); Ron Quarles <[rquarles@telluride-co.gov](mailto:rquarles@telluride-co.gov)>; Amy Markwell <[amym@sanmiguelcountyco.gov](mailto:amym@sanmiguelcountyco.gov)>; [kgeiger@telluride-co.gov](mailto:kgeiger@telluride-co.gov)

**Cc:** Michelle Haynes <[MHaynes@mtnvillage.org](mailto:MHaynes@mtnvillage.org)>; Amy Ward <[award@mtnvillage.org](mailto:award@mtnvillage.org)>; Paul Wisor <[pwisor@garfieldhecht.com](mailto:pwisor@garfieldhecht.com)>; [chris@alpineplanningllc.com](mailto:chris@alpineplanningllc.com)

**Subject:** Unit 17 - Ridge Club, Courtesy Referral

Good afternoon Kaye and Ron:

Attached is a courtesy referral application consistent with the County Settlement Agreement and Ridgeline Covenant for a two-step design review application for Unit 17 located at Lot 161D-1 on San Sophia Ridge regarding a proposed detached condominium with a height of 42' – 4 ½". Due to the size of the files – they can be found at the following link:

<https://mtnvillage.exavault.com/p/SHARED%20FOLDER%20FOR%20PLANNERS%20FILES%20BACK%20O%20CLEINT/Lot%20161D1-17%20Ridge%20Referral%20to%20SMC>

Mr. Christopher Hawkins of Alpine Planning, representing the property owner has submitted an application for an Initial Architectural Site Review (IASR) to be heard by the Design Review Board. The IASR is the first of a two-step design review process. This request is based on the information provided within the application. Mr. Hawkins has requested a waiver from the story pole requirement, stating in the application materials that *"Unit 17 is carved out of Lot 161D-1 and is located below the currently under construction home on Unit 15. There is no way the home will be visible from either Telluride or the Valley Floor since it is well below the geographic ridge. The highest roof elevation is approximately 10486 while the geographic ridge is located around approximately 10560. As a reference point, the roof on Unit 15 that is currently under construction to the north of and above Unit 17 has its highest roof ridge elevation of 10531.6' and you cannot see that from Telluride or the Valley Floor."*

The purpose of this email is to allow the County and Town to provide comments on this Design Review application and the story pole waiver request. Although the story pole waiver request is at the Planning

Director's discretion per the CDC, consistent with the last Ridge application for Unit 15 in 2016 which has a similar request to waive the story pole requirement, we are asking for County and Town of Telluride courtesy consent to waive the story pole requirement based upon the materials provided by the applicant. Mountain Village Staff would also be happy to arrange a site visit for this project if you determine it to be necessary. The deadline for comment on this referral is 21 days and otherwise January 28, 2021.

Staff anticipates this item to be heard at the February 4, 2021 Regular Design Review Board meeting – to be held remotely via Zoom. You may direct your questions to myself who is the main contact at the contact information listed below, Michelle Haynes, Planning and Development Services Director at [mhaynes@mtnvillage.org](mailto:mhaynes@mtnvillage.org), or Paul Wisor, Town Attorney at [pwisor@garfieldhecht.com](mailto:pwisor@garfieldhecht.com). You may also direct questions to the applicant, Mr. Christopher Hawkins [chris@alpineplanningllc.com](mailto:chris@alpineplanningllc.com).

Thank you all for your time and let me know if you have any questions or concerns.

J

John A Miller III, CFM

Senior Planner

Planning & Development Services

Town of Mountain Village

455 Mountain Village Blvd, Suite A

Mountain Village, CO 81435

O :: 970.369.8203

C :: 970.417.1789



For information about The Town of Mountain Village's response to COVID-19 (Coronavirus), please visit [townofmountainvillage.com/coronavirus/](https://www.townofmountainvillage.com/coronavirus/)

--  
For information about San Miguel County's response to COVID-19 (Coronavirus), please visit <https://www.sanmiguelcountyco.gov/590/Coronavirus>

Kaye Simonson, AICP  
Planning Director  
San Miguel County Planning Department  
Office: (970)369-5436  
Cell: (970)729-9929  
[www.sanmiguelcountyco.gov](http://www.sanmiguelcountyco.gov)

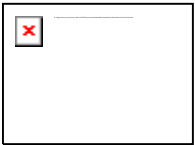



**Building and Planning Department**  
**Ron Quarles, Director**

---

## **MEMORANDUM**

**TO:** John A Miller III, Senior Planner, Town of Mountain Village

**FROM:** Phil Taylor, Senior Planner, Town of Telluride

**DATE:** January 26th, 2021

**Address:** 6 Tunnel Lane

**SUBJECT:** Initial Architectural Site Review (IASR) and story pole waiver request for Unit 17- The Ridge, Lot 161D-1.

---

The Planning and Building Department has the following comments on this case:

1. The Town of Telluride does not object to waiving the requirement to erect story poles on Lot 161D-1. The Town has no further comments on this request.
2. If the proposed detached condominium residence will not be visible from the Town of Telluride or the Valley Floor, the Town has no comments regarding the initial plans submitted by the applicant, Alpine Planning, LLC.

Thank you,

Philip Taylor, AICP

## John A. Miller

---

**From:** Jim Loebe  
**Sent:** Tuesday, January 19, 2021 11:44 AM  
**To:** John A. Miller  
**Subject:** RE: Class 3 Referral - New Detached Condo Home @ Unit 17, the Ridge

Hey John,

I'm not sure what their proposed construction equipment access will be for this site, but we'll need to sit down with the contractor before they break ground to put a communication plan together. Same comments for the other referral.

Thank you,

Jim Loebe  
Transit Director and Director of Parks and Recreation  
Town of Mountain Village  
O::970.369.8300  
M::970.729.3434

[Website](#) | [Facebook](#) | [Twitter](#) | [Instagram](#) | [Email Signup](#)

For information about The Town of Mountain Village's response to COVID-19 (Coronavirus), please visit [townofmountainvillage.com/coronavirus/](https://townofmountainvillage.com/coronavirus/)

**Si Usted necesita comunicarse conmigo y necesita servicio de traducción al español, simplemente háganoslo saber y podemos proporcionar tal servicio.**

---

**From:** John A. Miller <JohnMiller@mtnvillage.org>  
**Sent:** Monday, January 18, 2021 11:54 AM  
**To:** Finn KJome <FKJome@mtnvillage.org>; Steven LeHane <SLeHane@mtnvillage.org>; Jim Loebe <JLoebe@mtnvillage.org>; Chris Broady <CBroady@mtnvillage.org>; jim.telfire@montrose.net; jeremy@smpa.com; brien.gardner@blackhillscorp.com; kirby.bryant@centurylink.com; Forward jim.telluridefire.com <jim@telluridefire.com>  
**Cc:** JD Wise <JWise@mtnvillage.org>  
**Subject:** Class 3 Referral - New Detached Condo Home @ Unit 17, the Ridge

Good Afternoon All,

Below you will find a link to a proposed new home to be located at Lot 161D1-17, San Sophia Ridge. This lot is shown below and located directly below the existing home under construction at 7 Tunnel Lane. This project could be further complicated by the future development of Unit 19 which is directly off-screen of the image and shown in red dots – you will receive a separate referral for 19 shortly.

Link:  
<https://mtnvillage.exavault.com/p/SHARED%20FOLDER%20FOR%20PLANNERS%20FILES%20BACK%20TO%20CLEINT/Lot%20161D1-17%20Ridge%20Referral%20to%20SMC>



Please let me know if you have any questions or concerns.

Thanks,  
J

John A Miller III, CFM  
Senior Planner  
Planning & Development Services  
**Town of Mountain Village**  
455 Mountain Village Blvd, Suite A  
Mountain Village, CO 81435  
O :: 970.369.8203  
C :: 970.417.1789



For information about The Town of Mountain Village's response to COVID-19 (Coronavirus), please visit [townofmountainvillage.com/coronavirus/](https://townofmountainvillage.com/coronavirus/)  
esponse to COVID-19 (Coronavirus), please visit [townofmountainvillage.com/coronavirus/](https://townofmountainvillage.com/coronavirus/)

## John A. Miller

---

**From:** Finn KJome  
**Sent:** Tuesday, January 19, 2021 2:08 PM  
**To:** John A. Miller  
**Subject:** RE: Class 3 Referral - New Detached Condo Home @ Unit 17, the Ridge

John,  
All these lots have existing service lines for water and sewer. Make a comment to field verify existing utilities.  
Thanks Finn

---

**From:** John A. Miller <JohnMiller@mtnvillage.org>  
**Sent:** Monday, January 18, 2021 11:54 AM  
**To:** Finn KJome <FKJome@mtnvillage.org>; Steven LeHane <SLeHane@mtnvillage.org>; Jim Loebe <JLoebe@mtnvillage.org>; Chris Broady <CBroady@mtnvillage.org>; jim.telfire@montrose.net; jeremy@smpa.com; brien.gardner@blackhillscorp.com; kirby.bryant@centurylink.com; Forward jim.telluridefire.com <jim@telluridefire.com>  
**Cc:** JD Wise <JWise@mtnvillage.org>  
**Subject:** Class 3 Referral - New Detached Condo Home @ Unit 17, the Ridge

Good Afternoon All,  
Below you will find a link to a proposed new home to be located at Lot 161D1-17, San Sophia Ridge. This lot is shown below and located directly below the existing home under construction at 7 Tunnel Lane. This project could be further complicated by the future development of Unit 19 which is directly off-screen of the image and shown in red dots – you will receive a separate referral for 19 shortly.

Link:  
<https://mtnvillage.exavault.com/p/SHARED%20FOLDER%20FOR%20PLANNERS%20FILES%20BACK%20TO%20CLEINT/Lot%20161D1-17%20Ridge%20Referral%20to%20SMC>





Please let me know if you have any questions or concerns.

Thanks,  
J

John A Miller III, CFM  
Senior Planner  
Planning & Development Services  
**Town of Mountain Village**  
455 Mountain Village Blvd, Suite A  
Mountain Village, CO 81435  
O :: 970.369.8203  
C :: 970.417.1789



For information about The Town of Mountain Village's response to COVID-19 (Coronavirus), please visit [townofmountainvillage.com/coronavirus/](https://townofmountainvillage.com/coronavirus/)  
esponse to COVID-19 (Coronavirus), please visit [townofmountainvillage.com/coronavirus/](https://townofmountainvillage.com/coronavirus/)

## John A. Miller

---

**From:** Jim Boeckel <jim@telluridefire.com>  
**Sent:** Tuesday, January 19, 2021 9:04 AM  
**To:** John A. Miller  
**Subject:** Re: Class 3 Referral - New Detached Condo Home @ Unit 17, the Ridge

John,

This residence is required to have a fire sprinkler system installed and the sprinkler system is required to be monitored.

On Mon, Jan 18, 2021 at 11:53 AM John A. Miller <[JohnMiller@mtnvillage.org](mailto:JohnMiller@mtnvillage.org)> wrote:

Good Afternoon All,

Below you will find a link to a proposed new home to be located at Lot 161D1-17, San Sophia Ridge. This lot is shown below and located directly below the existing home under construction at 7 Tunnel Lane. This project could be further complicated by the future development of Unit 19 which is directly off-screen of the image and shown in red dots – you will receive a separate referral for 19 shortly.

Link:

<https://mtnvillage.exavault.com/p/SHARED%20FOLDER%20FOR%20PLANNERS%20FILES%20BACK%20TO%20CLEINT/Lot%20161D1-17%20Ridge%20Referral%20to%20SMC>



Please let me know if you have any questions or concerns.

Thanks,

J

John A Miller III, CFM

Senior Planner

Planning & Development Services

Town of Mountain Village

455 Mountain Village Blvd, Suite A

Mountain Village, CO 81435

O :: 970.369.8203

C :: 970.417.1789



For information about The Town of Mountain Village's response to COVID-19 (Coronavirus), please visit [townofmountainvillage.com/coronavirus/](https://townofmountainvillage.com/coronavirus/)

esponse to COVID-19 (Coronavirus), please visit [townofmountainvillage.com/coronavirus/](https://townofmountainvillage.com/coronavirus/)

--

**Jim Boeckel, Fire Marshal, Battalion Chief**

Telluride Fire Protection District  
PO Box 1645/131 West Columbia Avenue  
Telluride, CO 81435

[970-729-1454](tel:970-729-1454) (cell)

[970-728-3801](tel:970-728-3801) (office)

[970-728-3292](tel:970-728-3292) (fax)

[jim@telluridefire.com](mailto:jim@telluridefire.com)





**Agenda Item No. 8  
PLANNING AND DEVELOPMENT SERVICES  
DEPARTMENT**

455 Mountain Village Blvd.  
Mountain Village, CO 81435  
(970) 369-8250

**TO:** Mountain Village Design Review Board

**FROM:** John Miller, Senior Planner

**FOR:** Design Review Board Meeting, February 4, 2021

**DATE:** January 25, 2021

**RE:** A Review and Recommendation to Town Council regarding a rezone and density transfer application to rezone Blue Mesa Lodge Unit 23-A from an efficiency lodge zoning designation unit to a lodge zoning designation unit.

**PROJECT GEOGRAPHY**

**Legal Description:** *Condominium Unit 23-A, Lot 42B, Blue Mesa Lodge Condominiums*  
**Address:** 117 Lost Creek Lane  
**Owner:** The Entrust Administration, Bogna Nowak  
**Zoning:** Village Center  
**Existing Use:** Accommodations and Commercial  
**Proposed Use:** Multi-Family Residential and Commercial  
**Lot Size:** 0.16 Acres

**Adjacent Land Uses:**

- **North:** Village Center
- **South:** Village Center
- **East:** Village Center
- **West:** Village Center

**ATTACHMENTS**

- Exhibit A: Applicant's narrative
- Exhibit B: Proposed Modifications
- Exhibit C: Existing Conditions



**CASE SUMMARY:**

Keith Brown, acting on behalf of The Entrust Administration, is requesting to rezone Blue Mesa Lodge Unit 23-A from an efficiency lodge zoning designation to a lodge zoning designation. In order to accomplish this request, the unit in question must meet the rezoning criteria, must fit within the definition of a lodge unit per the Community Development Code (CDC), and acquire the requisite density for the increase in personal equivalents. A lodge unit is defined as a two-room space plus a mezzanine with up to two separate baths and a full kitchen.

## **BLUE MESA LODGES HISTORY**

### Zoning Designation History of Blue Mesa Lodges:

Blue Mesa Lodges (Lot 42B) were originally platted by the 1992 zoning map and preliminary PUD plat for eight condominiums and four hotels with a total person equivalent of 30 persons.

In 1997, Resolution No. 1997-0923-23 rezoned Lot 42B from 10 condominiums which included 18 lock-offs (the lock-offs carried no zoning designation or person equivalent, they were considered bedrooms to the condominium units), to 28 efficiency lodge units with a total of 14-person equivalent density. The Town allowed for parking to remain at 10 spaces, as a pre-existing condition and waived the additional four required parking spaces. The Town approved of the rezoning for the building as is, meaning that no interior or exterior alterations were required.

The condominium map unit configuration illustrates the units were labeled as Units A, B & C, units, for example, 20A, 20B, and 20C. These units had doors that connected the units between them. Each unit also had a door to the hallway so that they could be rented separately or used together. The most typical configuration was a former condominium unit and two lock-off bedrooms. In two cases, the 1998 condominium map only illustrated a unit A & B suite (no C unit).

### Rezone and Parking History of Unit 23-A:

Unit 23-A was purchased by The Entrust Administration in July of 2004. According to the applicant's narrative - since the purchase of the property the unit has been used almost exclusively as a long-term rental. The condominium map for Blue Mesa Lodge demonstrates the overall floor area of the unit at 424.7 sq. ft. In addition to the living area, there is also a 45 square foot exterior deck, a full kitchen that includes an oven with 4 burner range, a full-sized microwave, and a full-size refrigerator/freezer. . . The owners own a deeded interest in parking within the BML parking garage to meet the parking requirement of ½ a parking space.. To meet the density requirements, the applicants will acquire 0.25 units of density from a neighboring unit for this rezone.

*Figure 1. Unit 23-A configuration and proposed modifications*

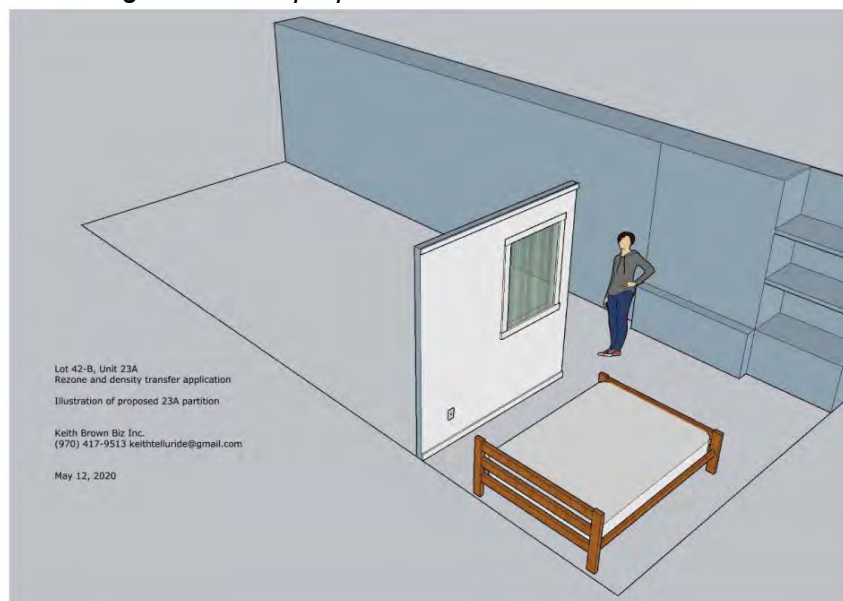

## **CRITERIA, ANALYSIS, AND FINDINGS**

The criteria for the decision to evaluate a variance and/or rezone that changes the zoning designation and/or density allocation assigned to a lot is listed below. The following criteria must be met for the review authority to approve the applications:

### **Chapter 17.4: DEVELOPMENT REVIEW PROCEDURES**

#### **17.4.9: Rezoning Process**

(\*\*\*)

3. Criteria for Decision: (\*\*\*)
  - a. The proposed rezoning is in general conformance with the goals, policies, and provisions of the Comprehensive Plan;

*Blue Mesa Lodge is not contemplated for redevelopment or future visioning in the Comprehensive Plan and is simply mapped as within the Village Center Zone District which allows for broad uses. The application conforms with Mountain Village Center Subarea Plan Principles, Policies, and Actions L., "Encourage deed-restricted units and full-time residency in Mountain Village Center, with provisions such as smaller units, the creation of a better sense of community, and other creative options."*

- b. The proposed rezoning is consistent with the Zoning and Land Use Regulations;

*The Zoning and Land Use Regulations allow for the requested rezone from efficiency lodge to lodge provided these criteria are met and the unit meets the definition of a lodge unit. Generally speaking, the Village Center zoning designation allows for lodge units as a permitted use consistent with the Land Use Regulations.*

*It should be noted that because the current configuration of the space does not include physical separation of the bedroom and living room area, that in order to meet the intent of the definition of lodge, there will be a required installation of a partition wall to separate the spaces (see Figure 1). The applicants will also be required to demonstrate the modifications staff would require prior to the finalization of the rezoning process. This includes the installation of a partition wall, fire sprinklers, and smoke detectors. The DRB and Town Council have determined in the past that a reconfiguration of an efficiency lodge unit could allow the unit to meet the requirements of a lodge unit and can be conditioned as part of any future approval.*

- c. The proposed rezoning meets the Comprehensive Plan project standards;

*There are no specific Comprehensive Plan project standards for Blue Mesa Lodge, thus, this criterion is not applicable.*

- d. The proposed rezoning is consistent with public health, safety, and welfare, as well as efficiency and economy in the use of land and its resources;

*The proposed rezoning presents no public health, safety or welfare issues and is an efficient use of what is a mixed-use building carrying residential attributes.*



- e. The proposed rezoning is justified because there is an error in the current zoning, [and/or] there have been changes in conditions in the vicinity [and/] or there are specific policies in the Comprehensive Plan that contemplate the rezoning;

*The proposed rezone is due to a change in condition in the vicinity, namely recent education and voluntary compliance regarding efficiency lodge zoning designations.*

- f. Adequate public facilities and services are available to serve the intended land uses;

*No additional public facilities are needed for the rezoning thus, they are adequate.*

- g. The proposed rezoning shall not create vehicular or pedestrian circulation hazards or cause parking, trash or service delivery congestion; and

*No change or negative impact.*

- h. The proposed rezoning meets all applicable Town regulations and standards.

*Provided the DRB determines that the addition of a partition wall is appropriate in order to meet the standards that a lodge unit has a two-room space the application would be compliant with all applicable Town regulations and standards at the time that the proposed partition wall is constructed, and the purchase of the additional 0.25-person equivalent density units is finalized. Staff is requesting that any approval condition the completion of these items prior to the recordation of the associated ordinance rezoning the unit.*

#### **17.4.10: Density Transfer Process**

(\*\*\*)

- D. Criteria for Decision

(\*\*\*)

- 2. Class 4 Applications. The following criteria shall be met for the Review Authority to approve a density transfer.

- a. The criteria for decision for a rezoning are met since such density transfer must be processed concurrently with a rezoning development application (except for MPUD development applications);
- b. The density transfer meets the density transfer and density bank policies; and.
- c. The proposed density transfer meets all applicable Town regulations and standards.

*Affirmed.*

#### **STAFF ANALYSIS**

Although the current configuration of the efficiency lodge unit does not meet the definition of a lodge unit per the CDC, the owner is proposing modifications to the space in order to provide for

a 2/3 partition wall between the living room area and bedroom area in order to create two rooms consistent with the lodge definition. At the time this construction is completed, then the proposed layout would be compliant. This configuration is consistent with past approved Blue Mesa Lodge rezone applications. The applicants have a total of 0.5-person equivalent density for Unit 23-A and will be required to purchase an additional 0.25-person equivalent in order to comply with the 0.75-person equivalent density requirements for a lodge unit prior to any finalization of the rezone request. Blue Mesa Lodges has never had onsite property management or amenities that would indicate accommodations use like a hotel therefore meeting the rezone criteria. Since Blue Mesa Lodges is also not identified in the Comprehensive Plan for redevelopment, rezoning the efficiency lodge unit to one lodge unit meets the Town criteria for a rezone application related to conformance with the Comprehensive Plan.

**DESIGN REVIEW BOARD CRITERIA FOR REVIEW:**

The Design Review Board's purview relates specifically to how density transfers and rezone applications may have design-related implications. There would be no substantive change to these units and no design review implications.

**RECOMMENDED MOTION:** The DRB may approve, continue, deny or modify the review and recommendation to Town Council regarding the proposed Density Transfer and Rezone for Unit 23-A, Lot 42B.

**Motion for Approval:** *I move to recommend the Town Council approve the rezone and density transfer application for Lot 42B, Blue Mesa Lodge Unit 23-A to rezone from an efficiency lodge zoning designation to lodge zoning designation with the following findings and conditions;*

*These recommendations are based on the following findings and conditions as noted in the staff report of record dated January 20, 2020:*

*Findings:*

- 1. At the time the requisite required density of .25 person equivalents is acquired, the applicant will meet the density required to execute a rezone from efficiency lodge to lodge zoning designation.*
- 2. At the time the modifications to the unit, including the installation of the partition wall as shown, are complete, the applicant will meet the required definition of a Lodge Unit per the CDC. A 2/3 partition wall meets the definition of creating two rooms consistent with the definition of a lodge zoning designation unit.*
- 3. Blue Mesa Lodge is not identified in the Comprehensive Plan for redevelopment.*

*Conditions:*

- 1. The applicant should work with the Blue Mesa HOA to update the declarations to recognize Unit 23-A as one Lodge unit.*
- 2. The Lot list shall be updated to reflect the rezone from one efficiency lodge unit to one lodge unit.*

3. *The applicant shall demonstrate the required requisite density has been acquired prior to recording the associated ordinance rezoning Unit 23-A from efficiency lodge to lodge unit.*
4. *The applicant shall obtain a building permit and complete the proposed modifications prior to recording the associated ordinance rezoning Unit 23-A from efficiency lodge to lodge unit.*

*This motion is based on the evidence and testimony provided at a public hearing held on February 6, 2020, with notice of such hearing as required by the Community Development Code.*

/JJM



# REZONING/DENSITY TRANSFER APPLICATION

**Planning & Development Services**  
 455 Mountain Village Blvd.  
 Mountain Village, CO 81435  
 970-728-1392  
 970-728-4342 Fax  
 cd@mtnvillage.org

Revised 1.3.2020

REZONING/DENSITY TRANSFER APPLICATION			
APPLICANT INFORMATION			
<b>Name:</b> Keith Brown, Keith Brown Biz Inc.	<b>E-mail Address:</b> keithtelluride@gmail.com		
<b>Mailing Address:</b> 117 Lost Creek Lane, #41-A,	<b>Phone:</b> 970 4176 9513		
<b>City:</b> Mountain Village,	<b>State:</b> CO	<b>Zip Code:</b> 81435	
<b>Mountain Village Business License Number:</b> 001049			
PROPERTY INFORMATION			
<b>Physical Address:</b> Lot 42B, Unit 23A, 117 Lost Creek Lane MV		<b>Acreage:</b> n/a	
<b>Zone District:</b> MV Center	<b>Zoning Designations:</b> efficiency lodge	<b>Density Assigned to the Lot or Site:</b> 0.5	
<b>Legal Description:</b> CONDO UNIT 23A BLUE MESA LODGE CONDO ACC TO MAP REC IN PLAT BK 1 PAGE 2423 AND AMENDED DECLARATION REC IN BK 586 PAGE 258 AND THE FIRST AMENDMENT TO AMENDED			
<b>Existing Land Uses:</b> efficiency lodge			
<b>Proposed Land Uses:</b> Lodge zoning			
OWNER INFORMATION			
<b>Property Owner:</b> Bogna Nowak, The Entrust Administration		<b>E-mail Address:</b> skindoctor725@hotmail.com	
<b>Mailing Address:</b> 4564 EAST MCNEIL STREET		<b>Phone:</b> 480 310 2801	
<b>City:</b> Phoenix	<b>State:</b> az	<b>Zip Code:</b> 85044	
DESCRIPTION OF REQUEST			
<p>Request to rezone to Lodge. 0.25 density will be purchased from Julie and Justin Peeler, Density Certificate is Number 053, dated April 09, 2020. The owner has 1/3 and 1/3 parking share in Lot 42 parking space 35 and 1/3 parking share in space 36 for a total of 1 full parking space ownership. A partition wall will be installed to meet the Lodge requirement.</p>			

Keith Brown Biz Inc.  
117 Lost Creek Lane, Apt 41-A  
Mountain Village, CO 81435 (970) 417-9513

---

May 12, 2020

**Development Narrative for the Rezone to a Lodge designation of Apt. 23-A, 117 Lost Creek Lane, Lot 42-B, Mountain Village, CO 81435**

I am the Owner Agent for Bogna Nowak, Beneficiary of the Entrust Administration Inc., for an application for the Rezone to a Lodge designation of Apt. 23-A.

The owner seeks a Rezone to a Lodge designation so the designation is in conformance with the physical attributes and intended uses of the property. The owner purchased on 7.19.2004 on the basis the property was a Residential Condo. She would not have purchased if an Efficiency Lodge designation had been known. The owner learned her condo had an Efficiency Lodge designation on May 14, 2019.

20-B condo is 425 square feet with a 28 square foot deck. The condo has been used exclusively for long-term rentals. The tenant is a photographer employed by Telski and the Telluride Tourism Board.

The owners intend to install a partition wall in accordance with the December 9, 2019 Room interpretation as it relates to zoning designation definitions. The owner Bogna Nowak owns at Blue Mesa Lodge parking totalling one unit parking. The owner is willing to re-allocate parking ownership to meet the half parking space required for the rezone of 23-A.

The owner is applying for another property rezone at this time, Apt. 23-B, Lot 42-B.

The application meets the applicable criteria for a Rezone to a Lodge designation as follows:

A. The proposed rezoning is in General Conformance with the goals, policies and provisions of the Comprehensive Plan (CP) because:

- A Lodge designation of 23-A will help promote a rich social fabric within the community (page 9 CP) by allowing the continued use of the condo for locally employed housing meeting the goal of where "small-town values are important and people can make social and emotional connections."
- A Lodge designation of 23-A is in compliance with the intended mixed-use of the Village Center Zone District.

B. The proposed rezoning is consistent with the Zoning and Land Use Regulations because:

- The Lodge designation is in keeping with the Land Use Plan Policy (page 39 CP) for a Mixed-Use Center.

- Given the prior use, the applicant believes a designation of Lodge is appropriate and reasonable for 23-A

C. The proposed rezoning meets the Comprehensive Plan project standards because:

- The 23-A building was designed, approved, built and managed as a Residential Condominium property.

D. The proposed rezoning is consistent with public health, safety and welfare as well as the efficiency and economy in the use of land and its resources because:

- The 23-A building was designed and approved as a residential condominium building and is physically suitable for Lodge use.
- A Lodge designation provides for a higher property valuation and range of use. That in turn helps create pride of ownership and a willingness to upgrade and improve the property beyond interior condo renovations.

The 23-A owners, along with the other owners of the property made substantial financial and personal contributions in upgrading and maintaining not only condominium interiors but also the building and plaza infrastructure. A partial list of infrastructure improvements includes garage fireproofing (2019), roof drainage, a snow melt system, heat tape safety circuit breakers (2009-2017), extensive waterproofing and plaza repairs (2016) and building structural repairs from snow melt salt damage (2009-10). Additionally the property owners allowed the town an easement to install the Sunset Plaza snow melt system and another easement allowing the town to use delivery vehicles across HOA property.

E. The proposed rezoning is justified because there are the following errors in the current zoning:

- 23-A condo as well as other units in the property have been used as long-term residences since the original construction. The history of the property is mixed-use, with long-term occupancy in multiple units, including 23-A. The original Lot 42 plat was and is for Condominium-Commercial, not Efficiency Lodge-Commercial use. Blue Mesa Lodge Lot 42-B had Residential Condominium designation for the first decade, until the 1998 Town resolution that changed the condominiums to Efficiency Lodge designation. There was no removal of full kitchens and no enforcement of the parking obligations in 1998 or afterwards.
- The 1997 application for conversion to Efficiency Lodge was at the request of the developer/declarant and not by a properly constituted HOA on behalf of Owners. The developer/declarant then recorded a misleading amended declaration (recording nbr 321574) as part of the HOA governing documents. The amended declaration stated the conversion was from a Residential Condo designation to a 'Residential Studio Apartment' designation 'for Residential use', which is a designation that did not and does not exist. The full chain of buyers (23 past & present owners contacted) thinking they had purchased Residential Condos. In sum, the rezone to Efficiency Lodge appears in error because the purchases and uses were for Residential Condominium.

F. The proposed rezoning shall not create vehicular or pedestrian circulation hazards or cause parking, trash or service delivery congestion because:

- The owner has parking ownership of 1 unit parking in total at the property.

G. The proposed rezoning meets all applicable Town regulations and standards because:

- The subject property was constructed to a Residential Condo standard.
- The Lodge designation allows for the intended use.

We want to thank town Planning and Town Council for considering this application and for the Council direction for the town to consider waiving related application fees.

Thank you,

Most Sincerely, Keith Brown, Keith Brown Biz Inc. for Bogna Nowak, Beneficiary of the Entrust Administration Inc.

Lot 42-B, Unit 23A  
Rezone and density transfer application

Illustration of proposed 23A partition

Keith Brown Biz Inc.  
(970) 417-9513 keithtelluride@gmail.com

May 12, 2020

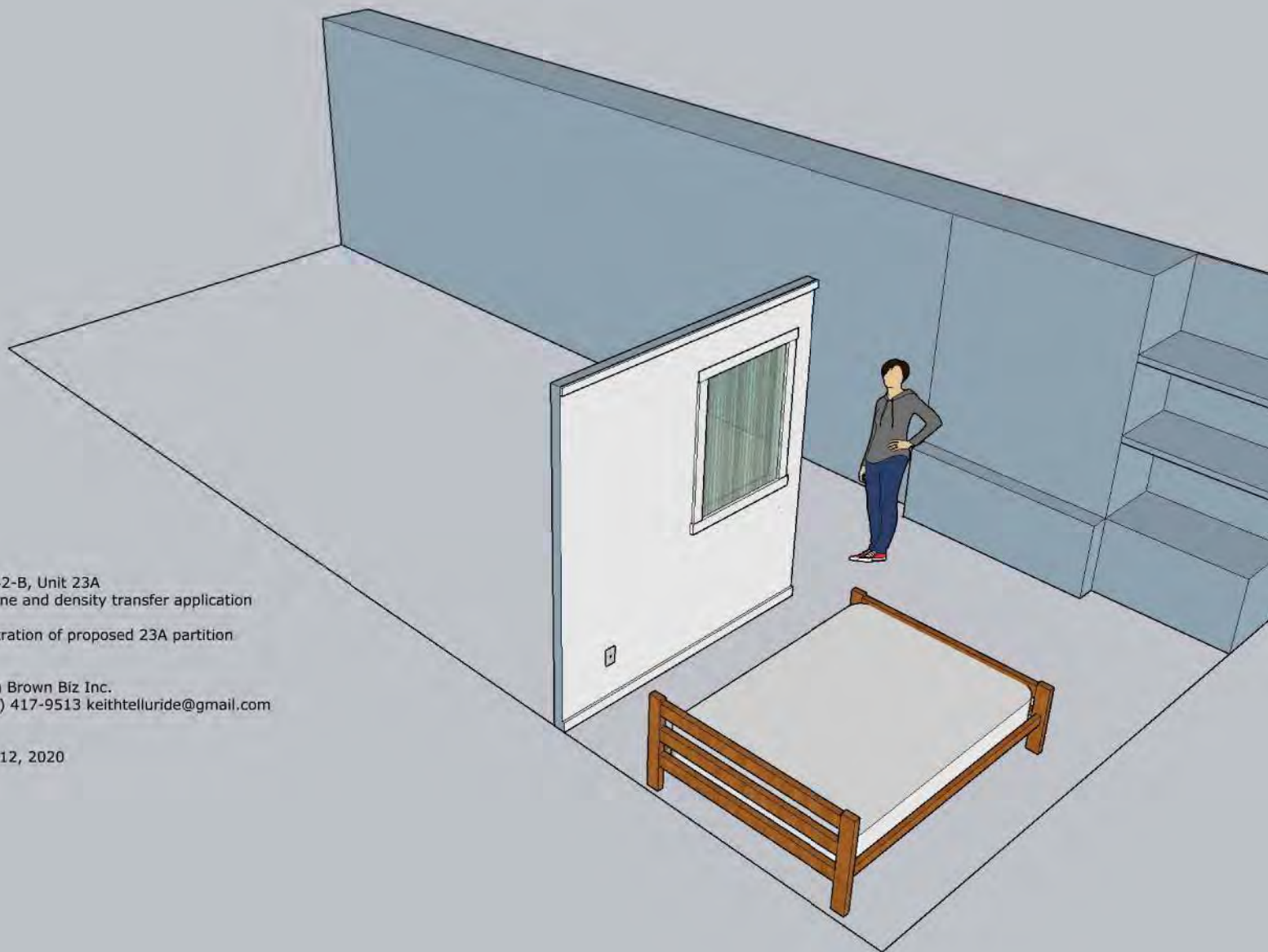



**8.30.19 note:**

This Plat Surface Addition is part of a full Survey made in 2015 for the Town of Mountain Village and the Blue Mesa Lodge HOA. The full survey was provided to the Town in 2015.

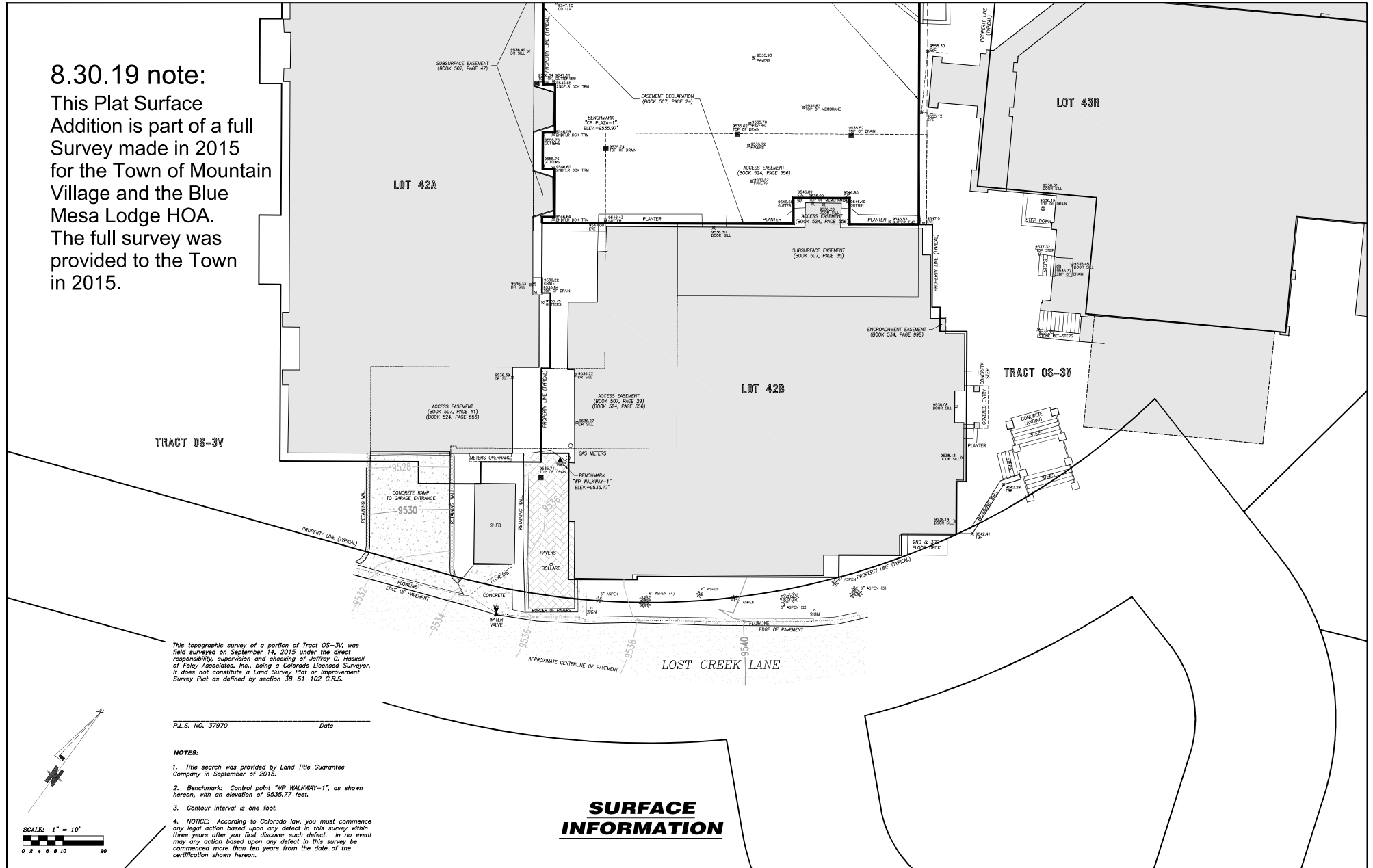

This topographic survey of a portion of Tract OS-3V, was field surveyed on September 14, 2015 under the direct responsibility, supervision and checking of Jeffrey C. Haskell of Foley Associates, Inc., being a Colorado Licensed Surveyor. It does not constitute a Land Survey Plat or Improvement Survey Plat as defined by section 38-51-102 C.R.S.

P.L.S. No. 37970 Date

- NOTES:**
- Title search was provided by Land Title Guarantee Company in September of 2015.
  - Benchmark: Control point "WP WALKWAY-1", as shown hereon, with an elevation of 9535.77 feet.
  - Contour interval is one foot.
  - NOTICE:** According to Colorado law, you must commence any legal action based upon any defect in this survey within three years after you first discover such defect. In no event may any action based upon any defect in this survey be commenced more than ten years from the date of the certification shown hereon.

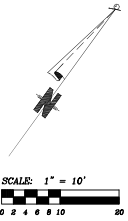

**SURFACE INFORMATION**

**Existing Conditions for  
The Gondola Plaza Parking Condominium**

Project Mgr:	JH	DATE	DESCRIPTION	DATE	BY
Technician:	MC				
Technician:					
Checked by:	KV				
Start date:	09/14/2015				

**FOLEY ASSOCIATES, INC.**  
 970-728-6153 970-728-6050 fax  
 P.O. BOX 1385  
 125 W. PACIFIC, SUITE B-1  
 TELLURIDE, COLORADO 81435

Drawing path: cwg\93007 Surface Addition 09-15.dwg  
 Sheet# 1 of 1 Project #: 93007

1-2429

7/12

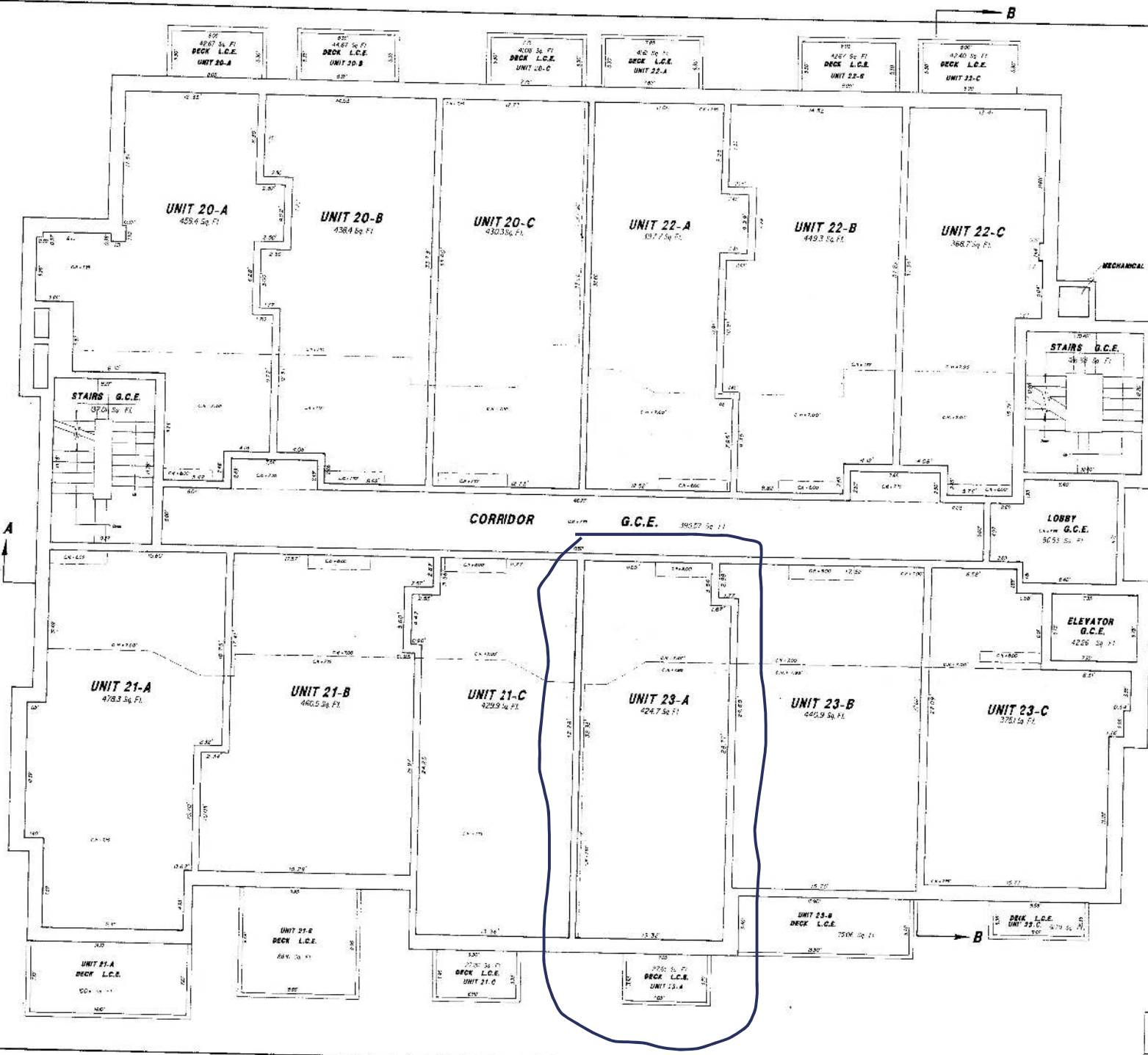

**SECOND FLOOR PLAN**

**FOLEY ASSOCIATES, INC. ENGINEERING & SURVEYING**  
 P.O. BOX 1385 TELLURIDE, COLORADO 81435 303-728-6153



**Agenda Item No. 9  
PLANNING AND DEVELOPMENT SERVICES  
DEPARTMENT**

455 Mountain Village Blvd.  
Mountain Village, CO 81435  
(970) 369-8250

**TO:** Mountain Village Design Review Board  
**FROM:** John Miller, Senior Planner  
**FOR:** Design Review Board Meeting, February 4, 2021  
**DATE:** January 25, 2021  
**RE:** A Review and Recommendation to Town Council regarding a rezone and density transfer application to rezone Blue Mesa Lodge Unit 23-B from an efficiency lodge zoning designation unit to a lodge zoning designation unit.

**PROJECT GEOGRAPHY**

**Legal Description:** *Condominium Unit 23-B, Lot 42B Blue Mesa Lodge Condominiums*  
**Address:** 117 Lost Creek Lane  
**Owner:** Blue Mesa 23B Family LTD, Bogna Nowak  
**Zoning:** Village Center  
**Existing Use:** Accommodations and Commercial  
**Proposed Use:** Multi-Family Residential and Commercial  
**Lot Size:** 0.16 Acres

**Adjacent Land Uses:**

- **North:** Village Center
- **South:** Village Center
- **East:** Village Center
- **West:** Village Center

**ATTACHMENTS**

- Exhibit A: Applicant's narrative
- Exhibit B: Proposed Modifications
- Exhibit C: Existing Conditions



**CASE SUMMARY:**

Keith Brown, acting on behalf of Blue Mesa 23B Family LTD, is requesting to rezone Blue Mesa Lodge Unit 23-B from an efficiency lodge zoning designation to a lodge zoning designation. In order to accomplish this request, the unit in question must meet the rezoning criteria, must fit within the definition of a lodge unit per the Community Development Code (CDC), and acquire the requisite density for the increase in personal equivalents. A lodge unit is defined as a two-room space plus a mezzanine with up to two separate baths and a full kitchen.

## **BLUE MESA LODGES HISTORY**

### Zoning Designation History of Blue Mesa Lodges:

Blue Mesa Lodges (Lot 42B) were originally platted by the 1992 zoning map and preliminary PUD plat for eight condominiums and four hotels with a total person equivalent of 30 persons.

In 1997, Resolution No. 1997-0923-23 rezoned Lot 42B from 10 condominiums which included 18 lock-offs (the lock-offs carried no zoning designation or person equivalent, they were considered bedrooms to the condominium units), to 28 efficiency lodge units with a total of 14-person equivalent density. The Town allowed for parking to remain at 10 spaces, as a pre-existing condition and waived the additional four required parking spaces. The Town approved of the rezoning for the building as is, meaning that no interior or exterior alterations were required.

The condominium map unit configuration illustrates the units were labeled as Units A, B & C, units, for example, 20A, 20B, and 20C. These units had doors that connected the units between them. Each unit also had a door to the hallway so that they could be rented separately or used together. The most typical configuration was a former condominium unit and two lock-off bedrooms. In two cases, the 1998 condominium map only illustrated a unit A & B suite (no C unit).

### Rezone and Parking History of Unit 21-C:

Unit 23-B was purchased by Blue Mesa 23B Family LTD in July of 2004 (at the same time as Unit 23-A). According to the applicant's narrative - since the purchase of the property the unit has been used almost exclusively as a long-term rental. The condominium map for Blue Mesa Lodge demonstrates the overall floor area of the unit at 424.7 sq. ft. In addition to the living area, there is also a 45 square foot exterior deck, a full kitchen that includes an oven with 4 burner range, a full-sized microwave, and a full-size refrigerator/freezer. .. The owners own a deeded interest in parking within the BML parking garage to meet the parking requirement of ½ a parking space. To meet the density requirements, the applicants will acquire 0.25 units of density from a neighboring unit for this rezone.

*Figure 1. Unit 23-B configuration and proposed modifications*

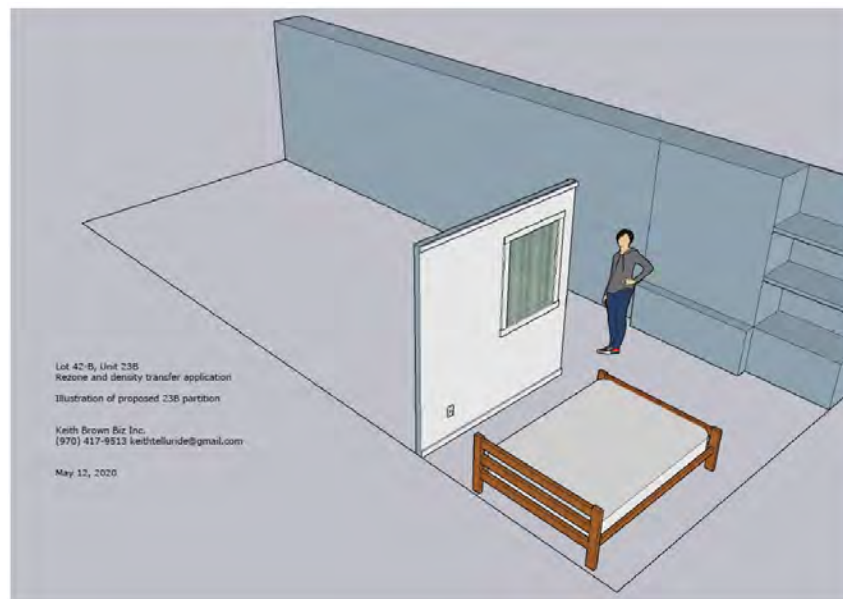

## **CRITERIA, ANALYSIS, AND FINDINGS**

The criteria for the decision to evaluate a variance and/or rezone that changes the zoning designation and/or density allocation assigned to a lot is listed below. The following criteria must be met for the review authority to approve the applications:

### **Chapter 17.4: DEVELOPMENT REVIEW PROCEDURES**

#### **17.4.9: Rezoning Process**

(\*\*\*)

3. Criteria for Decision: (\*\*\*)

- a. The proposed rezoning is in general conformance with the goals, policies, and provisions of the Comprehensive Plan;

*Blue Mesa Lodge is not contemplated for redevelopment or future visioning in the Comprehensive Plan and is simply mapped as within the Village Center Zone District which allows for broad uses. The application conforms with Mountain Village Center Subarea Plan Principles, Policies, and Actions L., "Encourage deed-restricted units and full-time residency in Mountain Village Center, with provisions such as smaller units, the creation of a better sense of community, and other creative options."*

- b. The proposed rezoning is consistent with the Zoning and Land Use Regulations;

*The Zoning and Land Use Regulations allow for the requested rezone from efficiency lodge to lodge provided these criteria are met and the unit meets the definition of a lodge unit. Generally speaking, the Village Center zoning designation allows for lodge units as a permitted use consistent with the Land Use Regulations.*

*It should be noted that because the current configuration of the space does not include physical separation of the bedroom and living room area, that in order to meet the intent of the definition of lodge, there will be a required installation of a partition wall to separate the spaces (see Figure 1). The applicants will also be required to demonstrate the modifications staff would require prior to the finalization of the rezoning process. This includes the installation of a partition wall, fire sprinklers, and smoke detectors. The DRB and Town Council have determined in the past that a reconfiguration of an efficiency lodge unit could allow the unit to meet the requirements of a lodge unit and can be conditioned as part of any future approval.*

- c. The proposed rezoning meets the Comprehensive Plan project standards;

*There are no specific Comprehensive Plan project standards for Blue Mesa Lodge, thus, this criterion is not applicable.*

- d. The proposed rezoning is consistent with public health, safety, and welfare, as well as efficiency and economy in the use of land and its resources;

*The proposed rezoning presents no public health, safety or welfare issues and is an efficient use of what is a mixed-use building carrying residential attributes.*

- e. The proposed rezoning is justified because there is an error in the current zoning, [and/or] there have been changes in conditions in the vicinity [and/] or there are specific policies in the Comprehensive Plan that contemplate the rezoning;

*The proposed rezone is due to a change in condition in the vicinity, namely recent education and voluntary compliance regarding efficiency lodge zoning designations.*

- f. Adequate public facilities and services are available to serve the intended land uses;

*No additional public facilities are needed for the rezoning thus, they are adequate.*

- g. The proposed rezoning shall not create vehicular or pedestrian circulation hazards or cause parking, trash or service delivery congestion; and

*No change or negative impact.*

- h. The proposed rezoning meets all applicable Town regulations and standards.

*Provided the DRB determines that the addition of a partition wall is appropriate in order to meet the standards that a lodge unit has a two-room space the application would be compliant with all applicable Town regulations and standards at the time that the proposed partition wall is constructed, and the purchase of the additional 0.25-person equivalent density units is finalized. Staff is requesting that any approval condition the completion of these items prior to the recordation of the associated ordinance rezoning the unit.*

#### **17.4.10: Density Transfer Process**

(\*\*\*)

##### D. Criteria for Decision

(\*\*\*)

2. Class 4 Applications. The following criteria shall be met for the Review Authority to approve a density transfer.

- a. The criteria for decision for a rezoning are met since such density transfer must be processed concurrently with a rezoning development application (except for MPUD development applications);
- b. The density transfer meets the density transfer and density bank policies; and.
- c. The proposed density transfer meets all applicable Town regulations and standards.

*Affirmed.*

#### **STAFF ANALYSIS**

Although the current configuration of the efficiency lodge unit does not meet the definition of a lodge unit per the CDC, the owner is proposing modifications to the space in order to provide for a 2/3 partition wall between the living room area and bedroom area in order to create two rooms consistent with the lodge definition. At the time this construction is completed, then the proposed layout would be compliant. This configuration is consistent with past approved Blue Mesa Lodge rezone applications. The applicants have a total of 0.5-person equivalent density for Unit 23-B

and will be required to purchase an additional 0.25-person equivalent in order to comply with the 0.75-person equivalent density requirements for a lodge unit prior to any finalization of the rezone request. Blue Mesa Lodges has never had onsite property management or amenities that would indicate accommodations use like a hotel therefore meeting the rezone criteria. Since Blue Mesa Lodges is also not identified in the Comprehensive Plan for redevelopment, rezoning the efficiency lodge unit to one lodge unit meets the Town criteria for a rezone application related to conformance with the Comprehensive Plan.

**DESIGN REVIEW BOARD CRITERIA FOR REVIEW:**

The Design Review Board's purview relates specifically to how density transfers and rezone applications may have design-related implications. There would be no substantive change to these units and no design review implications.

**RECOMMENDED MOTION:** The DRB may approve, continue, deny or modify the review and recommendation to Town Council regarding the proposed Density Transfer and Rezone for Unit 23-B, Lot 42B.

**Motion for Approval:** *I move to recommend the Town Council approve the rezone and density transfer application for Lot 42B, Blue Mesa Lodge Unit 23-B to rezone from an efficiency lodge zoning designation to lodge zoning designation with the following findings and conditions.*

*Findings:*

- 1. At the time the requisite required density of .25 person equivalents is acquired, the applicant will meet the density required to execute a rezone from efficiency lodge to lodge zoning designation.*
- 2. At the time the modifications to the unit, including the installation of the partition wall as shown, are complete, the applicant will meet the required definition of a Lodge Unit per the CDC. A 2/3 partition wall is adequate to interpret that the unit consists of two rooms, comporting with the definition of a lodge zoning designation unit.*
- 3. Blue Mesa Lodge is not identified in the Comprehensive Plan for redevelopment.*

*Conditions:*

- 1. The applicant should work with the Blue Mesa HOA to update the declarations to recognize Unit 23-B as one Lodge unit.*
- 2. The Lot list shall be updated to reflect the rezone from one efficiency lodge unit to one lodge unit.*
- 3. The applicant shall demonstrate the required requisite density has been acquired prior to recording the associated ordinance rezoning Unit 23-B from efficiency lodge to lodge unit.*
- 4. The applicant shall obtain a building permit and complete the proposed modifications prior to recording the associated ordinance rezoning Unit 23-B from efficiency lodge to lodge unit.*

*This motion is based on the evidence and testimony provided at a public hearing held on February 4, 2021, with notice of such hearing as required by the Community Development Code.*

/JJM



Keith Brown Biz Inc.  
117 Lost Creek Lane, Apt 41-A  
Mountain Village, CO 81435 (970) 417-9513

---

May 12, 2020

**Development Narrative for the Rezone to a Lodge designation of Apt. 23-B, 117 Lost Creek Lane, Lot 42-B, Mountain Village, CO 81435**

I am the Owner Agent for Bogna Nowak, Trustee of the Blue Mesa 23B Family Limited Partnership for an application for the Rezone to a Lodge designation of Apt. 23-B.

The owner seeks a Rezone to a Lodge designation so the designation is in conformance with the physical attributes and intended uses of the property. The owner purchased on 7.19.2004 on the basis the property was a Residential Condo. She would not have purchased if an Efficiency Lodge designation had been known. The owner learned her condo had an Efficiency Lodge designation on May 14, 2019.

20-B condo is 440.9 square feet with a 75 square foot deck. The condo has been used exclusively for long-term rentals.

The owners intend to install a partition wall in accordance with the December 9, 2019 Room interpretation as it relates to zoning designation definitions. The owner Bogna Nowak owns at Blue Mesa Lodge parking totalling one unit parking. The owner is willing to re-allocate parking ownership to meet the half parking space required for the rezone of 23-B.

The owner is applying for another property rezone at this time, Apt. 23-A, Lot 42-B.

The application meets the applicable criteria for a Rezone to a Lodge designation as follows:

A. The proposed rezoning is in General Conformance with the goals, policies and provisions of the Comprehensive Plan (CP) because:

- A Lodge designation of 23-B will help promote a rich social fabric within the community (page 9 CP) by allowing the continued use of the condo for locally employed housing meeting the goal of where "small-town values are important and people can make social and emotional connections."
- A Lodge designation of 23-B is in compliance with the intended mixed-use of the Village Center Zone District.

B. The proposed rezoning is consistent with the Zoning and Land Use Regulations because:

- The Lodge designation is in keeping with the Land Use Plan Policy (page 39 CP) for a Mixed-Use Center.

- Given the prior use, the applicant believes a designation of Lodge is appropriate and reasonable for 23-B.

C. The proposed rezoning meets the Comprehensive Plan project standards because:

- The 23-B building was designed, approved, built and managed as a Residential Condominium property.

D. The proposed rezoning is consistent with public health, safety and welfare as well as the efficiency and economy in the use of land and its resources because:

- The 23-B building was designed and approved as a residential condominium building and is physically suitable for Lodge use.
- A Lodge designation provides for a higher property valuation and range of use. That in turn helps create pride of ownership and a willingness to upgrade and improve the property beyond interior condo renovations.

The 23-B owners, along with the other owners of the property made substantial financial and personal contributions in upgrading and maintaining not only condominium interiors but also the building and plaza infrastructure. A partial list of infrastructure improvements includes garage fireproofing (2019), roof drainage, a snow melt system, heat tape safety circuit breakers (2009-2017), extensive waterproofing and plaza repairs (2016) and building structural repairs from snow melt salt damage (2009-10). Additionally the property owners allowed the town an easement to install the Sunset Plaza snow melt system and another easement allowing the town to use delivery vehicles across HOA property.

E. The proposed rezoning is justified because there are the following errors in the current zoning:

- 23-B condo as well as other units in the property have been used as long-term residences since the original construction. The history of the property is mixed-use, with long-term occupancy in multiple units, including 23-B. 23-B has an original, full kitchen. The original Lot 42 plat was and is for Condominium-Commercial, not Efficiency Lodge-Commercial use. Blue Mesa Lodge Lot 42-B had Residential Condominium designation for the first decade, until the 1998 Town resolution that changed the condominiums to Efficiency Lodge designation. There was no removal of full kitchens and no enforcement of the parking obligations in 1998 or afterwards.
- The 1997 application for conversion to Efficiency Lodge was at the request of the developer/declarant and not by a properly constituted HOA on behalf of Owners. The developer/declarant then recorded a misleading amended declaration (recording nbr 321574) as part of the HOA governing documents. The amended declaration stated the conversion was from a Residential Condo designation to a 'Residential Studio Apartment' designation 'for Residential use', which is a designation that did not and does not exist. The full chain of buyers (23 past & present owners contacted) thinking they had purchased

Residential Condos. In sum, the rezone to Efficiency Lodge appears in error because the purchases and uses were for Residential Condominium.

F. The proposed rezoning shall not create vehicular or pedestrian circulation hazards or cause parking, trash or service delivery congestion because:

- The owner has parking ownership of 1 unit parking in total at the property.

G. The proposed rezoning meets all applicable Town regulations and standards because:

- The subject property was constructed to a Residential Condo standard.
- The Lodge designation allows for the intended use.

We want to thank town Planning and Town Council for considering this application and for the Council direction for the town to consider waiving related application fees.

Thank you,

Most Sincerely, Keith Brown, Keith Brown Biz Inc. for Bogna Nowak, Trustee of the Blue Mesa 23B Family Limited Partnership

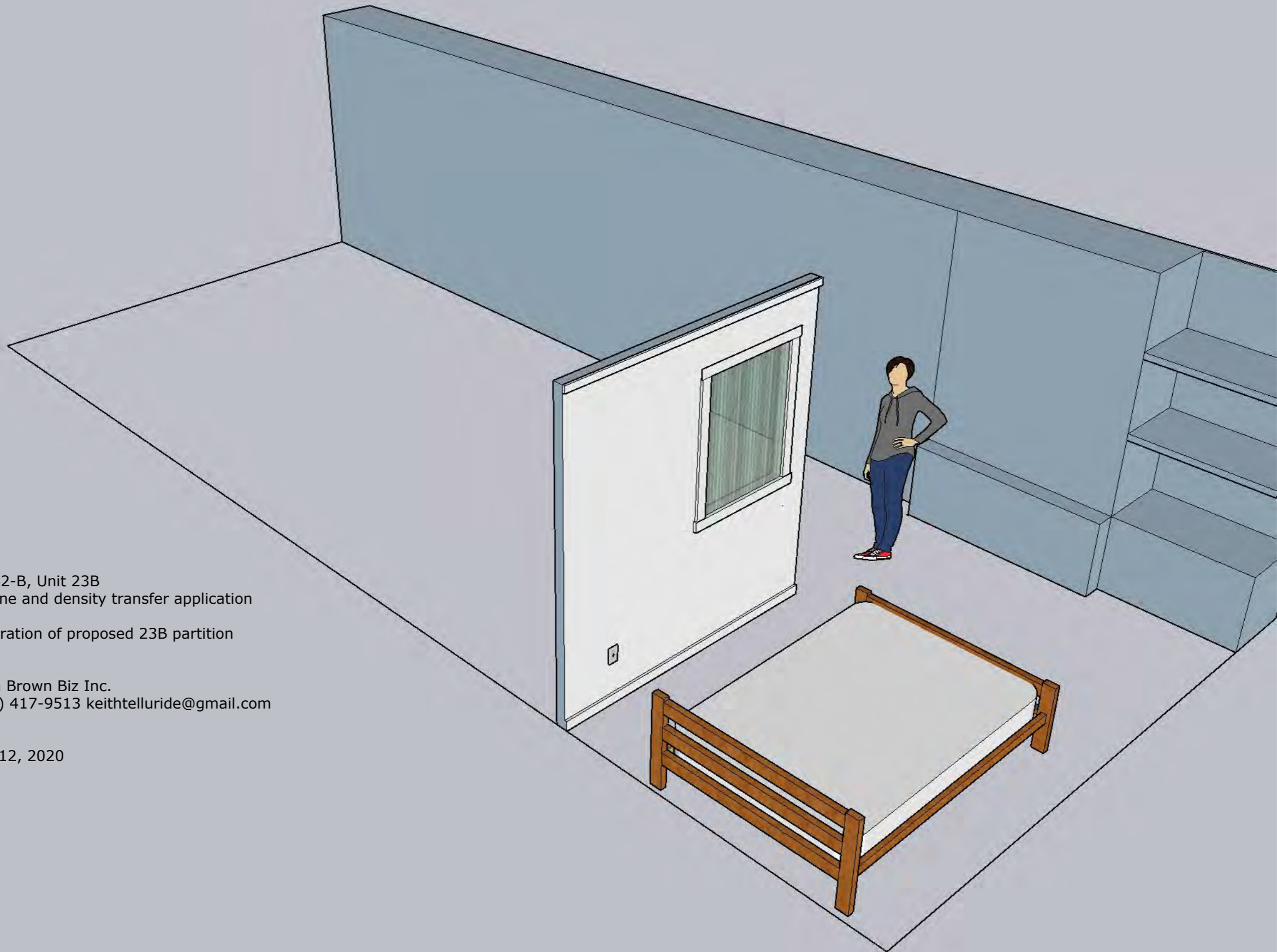

Lot 42-B, Unit 23B  
Rezone and density transfer application

Illustration of proposed 23B partition

Keith Brown Biz Inc.  
(970) 417-9513 keithtelluride@gmail.com

May 12, 2020

**8.30.19 note:**

This Plat Surface Addition is part of a full Survey made in 2015 for the Town of Mountain Village and the Blue Mesa Lodge HOA. The full survey was provided to the Town in 2015.

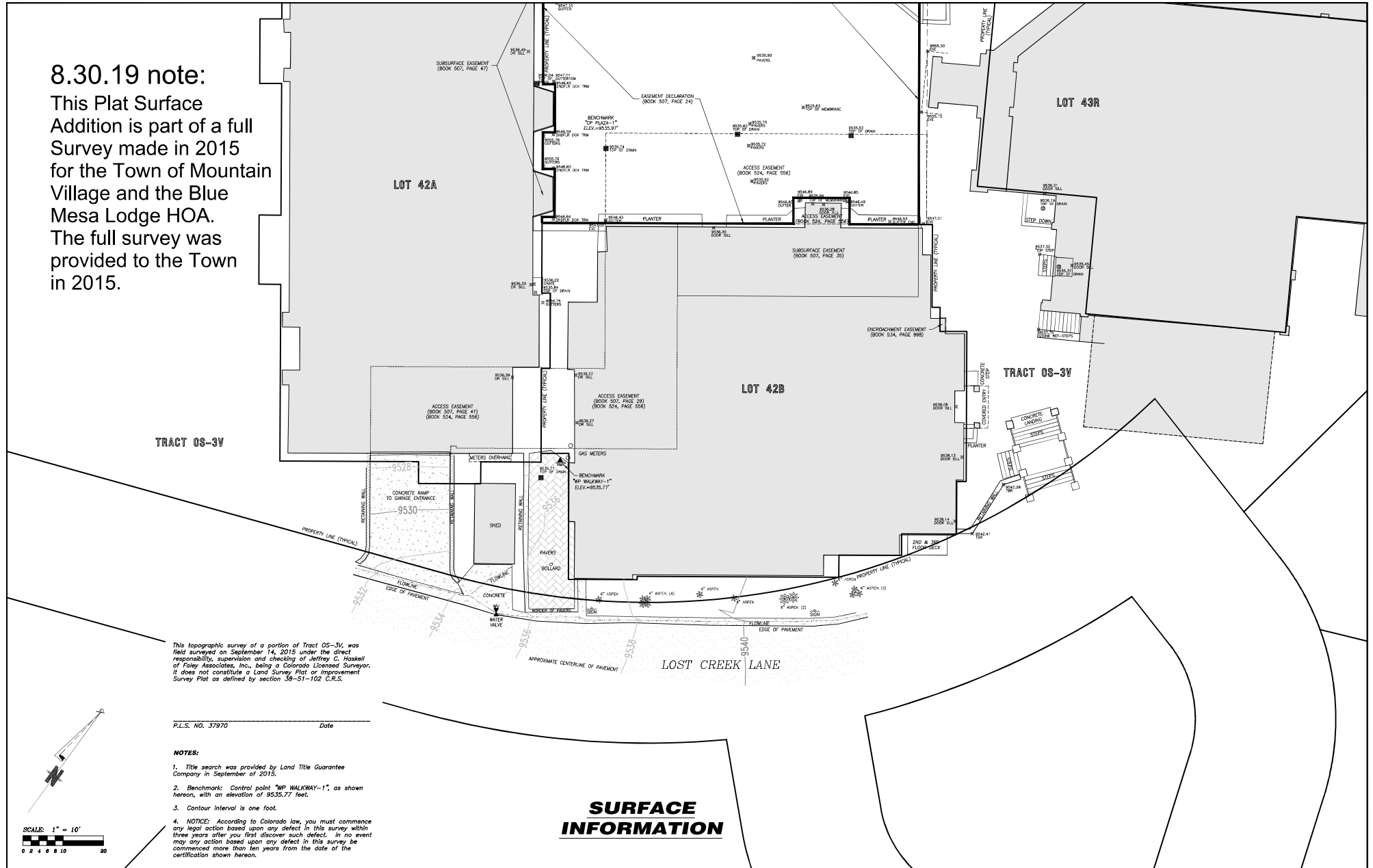

This topographic survey of a portion of Tract OS-3V, was field surveyed on September 14, 2015 under the direct responsibility, supervision and checking of Jeffrey C. Haskell of Foley Associates, Inc., being a Colorado Licensed Surveyor. It does not constitute a Land Survey Plat or Improvement Survey Plat as defined by section 38-51-102 C.R.S.

P.L.S. No. 37970 Date

- NOTES:**
- Title search was provided by Land Title Guarantee Company in September of 2015.
  - Benchmark: Control point "WP WALKWAY-1", as shown hereon, with an elevation of 9535.77 feet.
  - Contour interval is one foot.
  - NOTICE:** According to Colorado law, you must commence any legal action based upon any defect in this survey within three years after you first discover such defect. In no event may any action based upon any defect in this survey be commenced more than ten years from the date of the certification shown hereon.

**SURFACE INFORMATION**

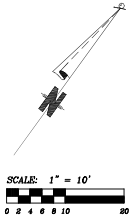

**Existing Conditions for  
The Gondola Plaza Parking Condominium**

Project Mgr:	JH	DATE	DESCRIPTION	DATE	BY
Technician:	MC				
Technician:					
Checked by:	KV				
Start date:	09/14/2015				



970-728-6153 970-728-6050 fax  
P.O. BOX 1385  
125 W. PACIFIC, SUITE B-1  
TELLURIDE, COLORADO 81435

Drawing path: cwg\93007 Surface Addition 09-15.dwg Sheet# 1 of 1 Project #: 93007

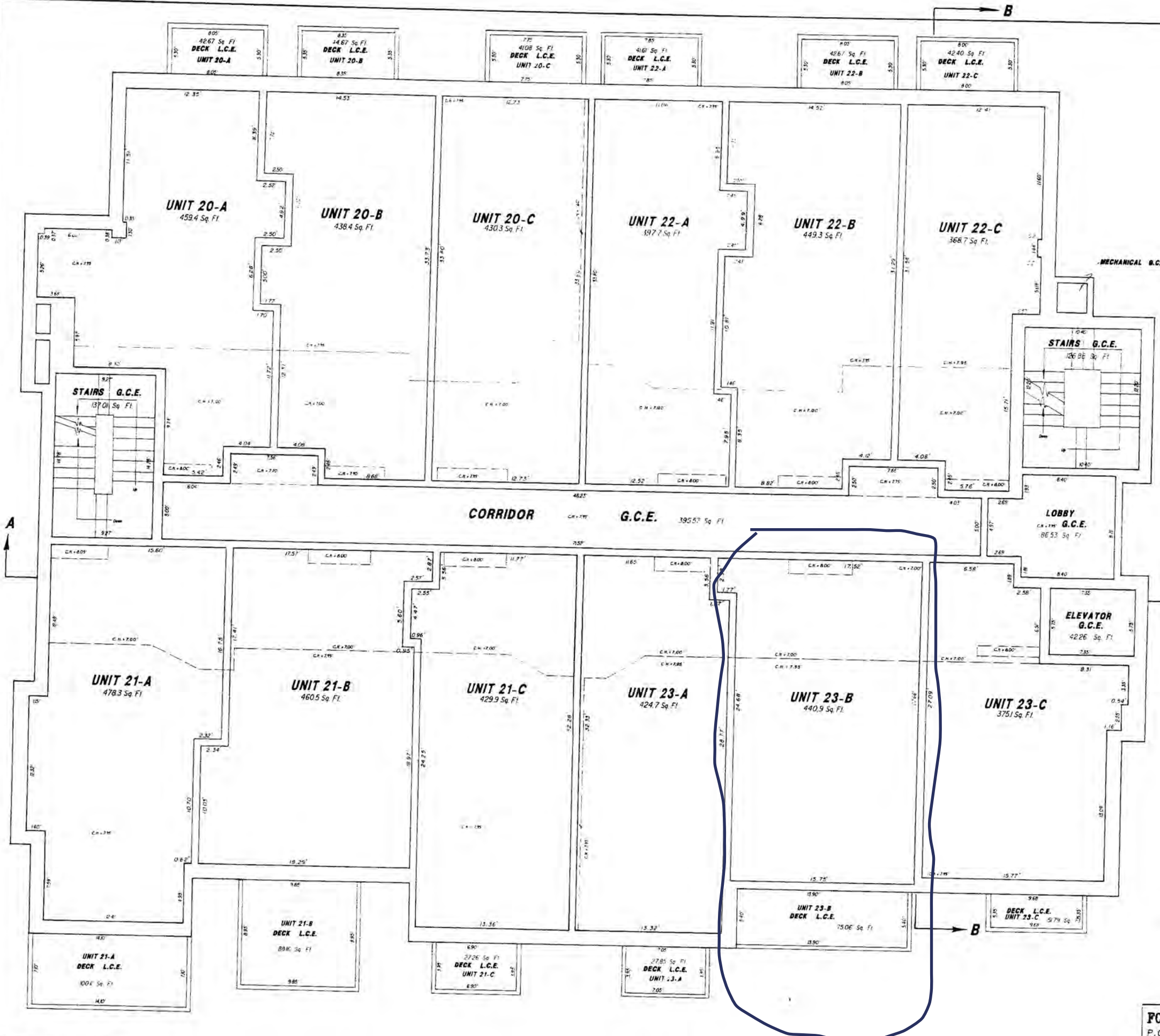

**SECOND FLOOR PLAN**

**POLEY ASSOCIATES, INC. ENGINEERING & SURVEYING**  
 P.O. BOX 1385 TELLURIDE, COLORADO 81435 303-728-6153



**Agenda Item No. 10  
PLANNING AND DEVELOPMENT SERVICES  
DEPARTMENT**

455 Mountain Village Blvd.  
Mountain Village, CO 81435  
(970) 369-8250

**TO:** Mountain Village Town Council  
**FROM:** John Miller, Senior Planner  
**FOR:** Design Review Board Meeting, February 4, 2021  
**DATE:** January 25, 2021  
**RE:** A Review and Recommendation to Town Council regarding a rezone and density transfer application to rezone Lot 60A, Unit C (La Chamonix) from (1) efficiency lodge zoning designation unit to one (1) Lodge zoning designation unit.

**PROJECT GEOGRAPHY**

**Legal Description:** Condominium Unit C, La Chamonix Condominiums  
**Address:** 650 Mountain Village Boulevard #C  
**Applicant:** Nicole Y. Pieterse  
**Owner:** JDBL.K, LLC  
**Zoning:** Village Center  
**Existing Use:** Accommodations and Commercial  
**Proposed Use:** Multi-Family Residential and Commercial  
**Unit Size:** 797 square feet

**Adjacent Land Uses:**

- **North:** Village Center
- **South:** Village Center
- **East:** Village Center
- **West:** Village Center

**ATTACHMENTS**

- Exhibit A: Applicant's narrative



**CASE SUMMARY:**

Nicole Y Pieterse, acting on behalf of the Owner JDBL.K, LLC is requesting to rezone Lot 60A, Unit C (La Chamonix C) from one efficiency lodge unit zoning designation to one lodge unit zoning designation. In order to accomplish this request, the unit must meet the rezoning criteria, must fit within the definition of a lodge unit per the Community Development Code (CDC), and must acquire the requisite density for the increase in person equivalents. A lodge unit is defined as a two-room space plus a mezzanine with up to two separate baths and a full kitchen

## Zoning Designation History of La Chamonix

Lot 60R-A (La Chamonix) was originally platted in 1986 under San Miguel County jurisdiction. At the time, the Lots were designated separately as 60R-A and 60R-B, with a total of 5 condominium units and approximately 7,600 square feet of commercial space (see reception no. 245470).

In 2002, by Resolution No. 2002-05014-09, the Lot Line between Lot 60A-R and 60B-R was vacated and the density was merged to create the following density assigned to the Lot:

<i>Proposed Platting Status</i>	
Lot 60R-AB	
5 Condominium units =	15 density
2 Efficiency Lodge =	<u>1 density</u>
	16 density
3 Employee Apartments =	<u>9 density</u>
	25 density
60R-AB	10,928 SF
	.2508724 Acres

Ultimately through subsequent density transfers and rezonings, the combined Lot 60RAB's density as assigned to today is as follows: 5 Condominium Units, 2 Efficiency Lodge Units, and commercial space on the ground floor. The parking for these units has been satisfied as part of a license agreement for parking within the Heritage Parking Garage.

## Rezone History of Unit C

According to Town Records Unit C was remodeled, expanded, and replatted with the consent of the Mountain Village in 2015 to include the addition of a second bathroom and a loft area. As evidenced by the condominium map shown below, Unit C approximately 797 sq. ft. and meets the definition of a lodge unit given the full kitchen, living area, separate bedroom, and loft space.

Figure 1. La Chamonix Unit C Condo Map dated 2015



## CRITERIA, ANALYSIS, AND FINDINGS



The criteria for the decision to evaluate a rezone that changes the zoning designation and/or density allocation assigned to a lot is listed below. The following criteria must be met for the review authority to approve a rezoning application:

### 17.4.9: Rezoning Process

(\*\*\*)

#### 3. Criteria for Decision: (\*\*\*)

- a. The proposed rezoning is in general conformance with the goals, policies, and provisions of the Comprehensive Plan;

*La Chamonix is not contemplated for redevelopment or future visioning in the Comprehensive Plan and is simply mapped as within the Village Center Zone District which allows for broad uses. The application conforms with Mountain Village Center Subarea Plan Principles, Policies and Actions L., "Encourage deed-restricted units and full-time residency in Mountain Village Center, with provisions such as smaller units, the creation of a better sense of community, and other creative options."*

- b. The proposed rezoning is consistent with the Zoning and Land Use Regulations;

*The Zoning and Land Use Regulations allow for a rezone from efficiency lodge to lodge provided these criteria are met and the unit meets the definition of a lodge unit. The Village Center Zoning allows for broad uses including lodge units.*

- c. The proposed rezoning meets the Comprehensive Plan project standards;

*There are no specific Comprehensive Plan project standards for La Chamonix, thus, these criteria are not applicable.*

- d. The proposed rezoning is consistent with public health, safety, and welfare, as well as efficiency and economy in the use of land and its resources;

*The proposed rezoning presents no public health, safety or welfare issues and is an efficient use of what is a mixed-use building carrying residential attributes.*

- e. The proposed rezoning is justified because there is an error in the current zoning, [and/or] there have been changes in conditions in the vicinity [and/] or there are specific policies in the Comprehensive Plan that contemplate the rezoning;

*The proposed rezone is due to a change in condition in the vicinity, namely recent education and voluntary compliance regarding efficiency lodge zoning designations.*

- f. Adequate public facilities and services are available to serve the intended land uses;

*No additional public facilities are needed for the rezone thus, they are adequate.*

- g. The proposed rezoning shall not create vehicular or pedestrian circulation hazards or cause parking, trash or service delivery congestion; and

*No change or negative impact.*

- h. The proposed rezoning meets all applicable Town regulations and standards.

*Affirmed.*

**17.4.10: Density Transfer Process**

(\*\*\*)

- D. Criteria for Decision

(\*\*\*)

2. Class 4 Applications. The following criteria shall be met for the Review Authority to approve a density transfer.

- a. The criteria for decision for a rezoning are met, since such density transfer must be processed concurrently with a rezoning development application (except for MPUD development applications);
- b. The density transfer meets the density transfer and density bank policies; and .
- c. The proposed density transfer meets all applicable Town regulations and standards.

*Affirmed. See the criteria for rezoning.*

**DESIGN REVIEW BOARD CRITERIA FOR REVIEW:**

The Design Review Board's purview relates specifically to how density transfers and rezone applications may have design-related implications. There would be no substantive change to these units and no design review implications.

**STAFF ANALYSIS**

The existing configuration of the unit meets the definition of a lodge unit per the CDC given the 2015 renovation to the space. The applicants' have a total of 0.5 person equivalent density associated with the unit. Therefore they will be required and have suggested that they will obtain the necessary 0.25 person equivalent densities required to rezone the unit. La Chamonix does not have onsite property management or amenities that would indicate accommodations use like a hotel so that it otherwise meets the rezone criteria. Since La Chamonix is also not identified in the Comprehensive Plan for redevelopment, rezoning one efficiency lodge unit to one lodge unit meets the town criteria for a rezone application.

**RECOMMENDED MOTION:**

*I move to recommend the Town Council approve the rezone and density transfer application for Lot 60RA, La Chamonix Unit C to rezone the subject unit from one (1) efficiency lodge zoning designations to one (1) Lodge zoning designation with the following findings and conditions as noted in the staff report of record dated January 25, 2021, and with the following findings:*

*Findings:*

- 1. *At the time the requisite required density of .25 person equivalents is acquired, the applicant will meet the density required to execute a rezone from efficiency lodge to lodge zoning designation.*

2. *La Chamonix is not identified in the Comprehensive Plan for redevelopment.*

*Conditions:*

1. *The applicant should work with the La Chamonix HOA to update the declarations to recognize Unit C as one Lodge unit.*
2. *The Lot list shall be updated to reflect the rezone from one efficiency lodge unit to one lodge unit.*
3. *The applicant shall demonstrate the required requisite density has been acquired prior to recording the associated ordinance rezoning Lot 60RA Unit C from efficiency lodge to lodge unit.*

*This motion is based on the evidence and testimony provided at a public hearing held on February 4, 2020 with notice of such hearing as required by the Community Development Code.*

*/jjm*



# REZONING/DENSITY TRANSFER APPLICATION

**Planning & Development Services**  
 455 Mountain Village Blvd.  
 Mountain Village, CO 81435  
 970-728-1392  
 970-728-4342 Fax  
 cd@mtnvillage.org

Revised 2.26.18

REZONING/DENSITY TRANSFER APPLICATION			
APPLICANT INFORMATION			
<b>Name:</b> Nicole Y. Pieterse, Atty.		<b>E-mail Address:</b> nicole.rplaw@gmail.com	
<b>Mailing Address:</b> PO Box 2673		<b>Phone:</b> 970-708-0411	
<b>City:</b> Telluride	<b>State:</b> CO	<b>Zip Code:</b> 81435	
<b>Mountain Village Business License Number:</b> 005396			
PROPERTY INFORMATION			
<b>Physical Address:</b> 650 Mountain Village Boulevard #C		<b>Acreage:</b> 797 square feet	
<b>Zone District:</b> Village Center	<b>Zoning Designations:</b> Efficiency Lodge	<b>Density Assigned to the Lot or Site:</b> Lodge	
<b>Legal Description:</b> CONDOMINIUM UNIT C, LE CHAMONIX CONDOMINIUMS (see title commitment submitted herewith)			
<b>Existing Land Uses:</b> residential condominium			
<b>Proposed Land Uses:</b> same			
OWNER INFORMATION			
<b>Property Owner:</b> JDBL.K, LLC		<b>E-mail Address:</b> jtkappes@mac.com	
<b>Mailing Address:</b> 4 Victoria Bluff		<b>Phone:</b> (843) 816-3501	
<b>City:</b> Bluffton	<b>State:</b> SC	<b>Zip Code:</b> 29910	
DESCRIPTION OF REQUEST			
Rezone/Density Transfer - Le Chamonix Condominium Unit C (from Efficiency Lodge to Lodge)			

## Narrative

### **Unit C, Le Chamonix Condominiums Rezone/Density Transfer from Efficiency Lodge to Lodge Unit**

The proposed rezone and concurrent density transfer to officially designate Le Chamonix Unit C as a Lodge unit meets the requirements set forth in Sections 17.3.8, 17.4.9 and 17.4.10 of the Community Development Code and should be approved for the following reasons:

1. The proposed rezoning is in general conformance with the goals, policies and provisions of the Comprehensive Plan because Lodge Units are identified in the Comprehensive Plan as an appropriate use within this location (Village Center) of Mountain Village (“MV”).
2. The proposed rezoning is consistent with MV Zoning and Land Use Regulations because: Lodge units are an allowed use (by right) in the Village Center zone district and Unit C meets the spatial requirements of a Lodge unit (living area, separate bedroom, 2 separate baths and a full kitchen).
3. The proposed rezoning meets the Comprehensive Plan project standards for the Village Center Subarea and would not have any impact on future coordination with development of surrounding parcels.
4. The proposed rezoning is consistent with public health, safety and welfare, as well as efficiency and economy in the use of land and its resources because Unit C is actually used as a Lodge Unit, which for years has been consistent with and does not adversely impact surrounding uses, public health, safety or welfare.
5. The proposed rezoning is justified because Unit C was either improperly designated an Efficiency Lodge Unit and/or conditions have changed such that Unit C is better characterized as a Lodge Unit as opposed to an Efficiency Lodge Unit. For example: Unit C contains a full kitchen and was expanded, remodeled and re-platted, with MV authorization, in 2015 consistent with a Lodge Unit. The Comprehensive Plan contemplates a rezoning because the use is appropriate for the Subarea.
6. Adequate public facilities and services are available to serve the intended land uses because the proposed rezone does not contemplate any change in how Unit C is

actually used. Accordingly, the rezone will not require any additional public facilities or services.

7. The proposed rezoning will not create vehicular or pedestrian circulation hazards or cause parking, trash or service delivery congestion because the proposed rezone does not contemplate any additional traffic and a dedicated parking space already exists for Unit C.
8. The proposed rezoning of Unit C to a Lodge Unit meets all applicable Town regulations and standards as set forth above.
9. Unit C's owner will acquire .25 person equivalents of density in order to meet the person equivalents requirements of a Lodge Unit.
10. Le Chamonix Condominiums do not have on-site property management or any hotel-like amenities (i.e., no front desk, spa facilities, conference space, valet parking, concierge service, room service, etc.).
11. Unit C has a dedicated space assigned to it in the Heritage Plaza Building.

Respectfully submitted 12/31/19

442332  
 REPLAT  
 LE CHAMONIX CONDO ASSN,  
 JDBL.K LLC  
 TO  
 REPLAT  
 LA CHAMONIX CONDOS  
 UNIT C

State of Colorado )  
 County of San Miguel ) ss  
 Filed for Record at 11:00 O'Clock  
 A.M. MAY 4, 2016  
 and duly recorded in plat  
 book PLAT 1 page 4797-4798

M. Kathleen Erie  
 County Clerk & Recorder  
 By: *[Signature]* Deputy  
 Fees: 21.00

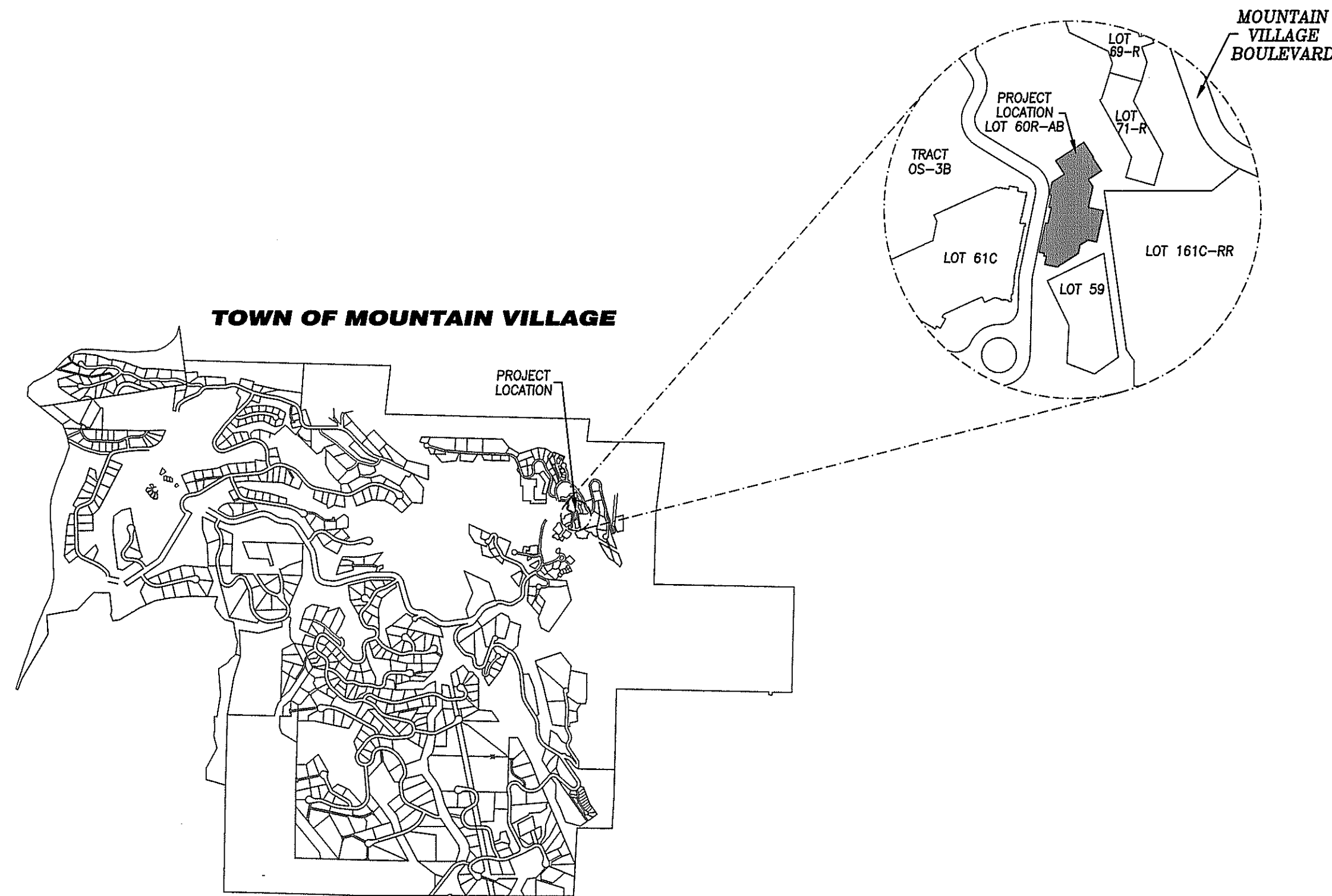

VICINITY MAP  
 NOT TO SCALE

Unit	Square Footage	Percentage	Unit Classification for purposes of voting only
Unit A	1,109	6.5%	Residential
Unit B	482	2.8%	Residential
Unit C	797	4.7%	Residential
Unit D	1,531	9.0%	Residential
Unit E	1,375	8.1%	Residential
Unit F	1,711	10.1%	Residential
Unit G1	1,255	7.4%	Commercial
Unit G2	910	5.4%	Commercial
Unit H	2,159	12.7%	Commercial
Unit I	3,783	22.3%	Commercial
	1,832	10.8%	Residential
	16,944	100%	

**MORTGAGEE CONSENT:**

The undersigned Alpine Bank, a Colorado Banking Corporation, as a Beneficiary of that certain Deed of Trust dated March 20, 2013 which constitutes a lien upon Unit C, recorded at Reception No. 427373 in the Official Records, hereby consents to the Unit C Expansion and re-plat of real property as depicted on this Map amendment.

Alpine Bank, a Colorado Banking Corporation  
 By: *[Signature]*  
 Printed Name: Todd Baize  
 Title: Vice President  
 STATE OF COLORADO  
 COUNTY OF SAN MIGUEL )ss

Acknowledged, subscribed and sworn to before me this 1 day of March, 2016  
 by Todd Baize as Vice President of Alpine Bank, a Colorado Banking Corporation.

My commission expires April 12, 2016  
 Witness my hand and official seal.

NICOLE Y. PIETERSE  
 NOTARY PUBLIC  
 STATE OF COLORADO  
 My Commission Expires 04/12/16

Notary Public

**TOWN APPROVAL:**

I, Stan Van Nimmen, as the Community Development Director of Mountain Village, Colorado, do hereby certify that this Map has been approved by the Town in accordance with the Community Development Code as a staff subdivision.

*[Signature]* Date: 3-26-16  
 as Community Development Director

**TITLE INSURANCE COMPANY CERTIFICATE:**

Land Title Guarantee Company does hereby certify that we have examined the title to the property that is the subject of this Map and have determined that title to the same is currently vested in the name of JDBL.K, LLC, a Colorado limited liability company and is free and clear of all liens and taxes, except those taxes for the current year, including all taxes now or heretofore assessed, due or payable and further except as follows: Deed of trust recorded at Reception No. 427373.

*[Signature]* Date: 3/21/16  
 Title Insurance Company Representative

**COUNTY TREASURER'S CERTIFICATE:**

I certify that according to the records in the San Miguel county Treasurer's office, there are no liens against Unit C for unpaid State, county or municipal taxes, assessments or other amounts certified to the County Treasurer for collection.

Dated this 18th day of March, 2016.

*[Signature]*  
 San Miguel County Treasurer



**RECORDER'S CERTIFICATE:**

This Condominium Map was filed for record in the office of the San Miguel County Clerk and Recorder on this 4th day of MAY, 2016,  
 at Plat Book 433-438  
 Page 4797-4798  
 Reception No. 442332  
 Time 11:00 A.M.

*[Signature]*  
 San Miguel County Clerk

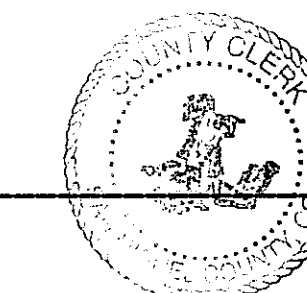

**CERTIFICATE OF OWNERSHIP (cont.):**

IN WITNESS WHEREOF, the Association and Owner execute this Map amendment as of March 4, 2016, 2016.

ASSOCIATION: *[Signature]*  
 Le Chamonix Condominium Association, a Colorado nonprofit corporation.

Printed Name: Bob Gleason

Title: President

STATE OF COLORADO  
 COUNTY OF SAN MIGUEL )ss

Acknowledged, subscribed and sworn to before me this 4 day of March, 2016  
 by Bob Gleason, as the President of Le Chamonix Condominium Association, a Colorado nonprofit corporation.

My commission expires 4/28/2020  
 Witness my hand and official seal.

Notary Public

NICOLE Y. PIETERSE  
 NOTARY PUBLIC  
 STATE OF COLORADO  
 NOTARY ID 19964000311  
 MY COMMISSION EXPIRES APRIL 12, 2020

OWNER:

JDBL.K, LLC

By: *[Signature]*  
Jonathan T. Kappes, Manager

STATE OF COLORADO  
 COUNTY OF SAN MIGUEL )ss

Acknowledged, subscribed and sworn to before me this 14 day of March, 2016  
 by Jonathan T. Kappes as the Manager of JDBL.K, LLC, a Colorado limited liability company.

My commission expires 4/12/2020  
 Witness my hand and official seal.

Notary Public

NICOLE Y. PIETERSE  
 NOTARY PUBLIC  
 STATE OF COLORADO  
 NOTARY ID 19964000311  
 MY COMMISSION EXPIRES APRIL 12, 2020

**SURVEYOR'S CERTIFICATE:**

I, Jeffrey C. Haskell, being a Registered Land Surveyor in the State of Colorado, do hereby certify that this map and survey of the FIRST AMENDMENT TO LE CHAMONIX CONDOMINIUMS AMENDED AND RESTATED CONDOMINIUM MAP (the "Map")(i) was made under my direct supervision, responsibility and checking; (ii) is true and accurate to the best of my knowledge and belief; (iii) is clear and legible; (iv) contains all the information required by C.R.S. 38-33.3-209; and (v) that all monuments and markers were set as required by Articles 50 and 51 of Title 38, C.R.S.

Dated this 29th day of February, 2016.

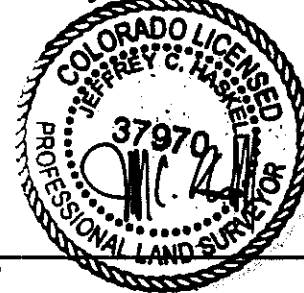

Jeffrey C. Haskell PLS 37970

**CERTIFICATE OF OWNERSHIP:**

KNOW ALL PERSONS BY THESE PRESENTS THE FOLLOWING:

1. JDBL.K, LLC a Colorado limited liability company ("Owner"), is the owner of CONDOMINIUM UNIT C, LE CHAMONIX CONDOMINIUMS, ACCORDING TO THE AMENDED AND RESTATED CONDOMINIUM MAP RECORDED OCTOBER 1, 2003 IN PLAT BOOK 1 AT PAGE 3190, AND AS DEFINED AND DESCRIBED IN THE CONDOMINIUM DECLARATION RECORDED DECEMBER 29, 1986 IN BOOK 432 AT PAGE 774 AS RERECORDED JANUARY 5, 1987 IN BOOK 433 AT PAGE 118, COUNTY OF SAN MIGUEL, STATE OF COLORADO ("Unit C").

(The above-referenced map and declaration for Le Chamonix Condominiums and all amendments and supplements thereto are referred to respectively herein as the "Map" and the "Declaration" and collectively as the "Governing Documents.")

2. The Owner has elected to create additional floor area within Unit C and to expand Unit C's boundaries as depicted hereon ("Unit C Expansion"), and to cause the Governing Documents to be amended pursuant to the appropriate sections of the Declaration.

3. Pursuant to its authority and according to the relevant provisions of the Declaration, the Le Chamonix Condominium Association, a Colorado nonprofit corporation ("Association") acting through its Board of Managers, and with approval of the Association members and Le Chamonix Unit owners and their lenders in accordance with the Declaration and C.R.S. 38-33.3-217, has approved and does hereby approve the Unit C Expansion, this Map amendment, and the related Fifth Amendment to the Declaration of Covenants, Conditions and Restrictions for Le Chamonix Condominiums recorded in the office of the San Miguel County Clerk and Recorder ("Official Records") on the same date as this Map amendment at Reception No. 442332 ("Fifth Declaration Amendment") of the Official Records.

4. Association property incorporated into the Unit C Expansion was transferred to Owner by Quit Claim on the same date as this Map amendment at Reception No. 442332 of the Official Records.

5. All other terms and conditions contained in the Governing Documents, not specifically modified or altered by this Map amendment, shall remain unmodified and shall continue in full force and effect.

First Amendment to Le Chamonix Condominiums Amended and Restated Condominium Map, located on Lot 60R-AB, Town of Mountain Village.

Project Mgr:	Rev.	Description	Date	By
JH				
Technician:	MC			
Checked by:	KV			
Start date:	04/01/2015			

PAGE 4797



970-728-6153 970-728-6050 fax  
 P.O. BOX 1385  
 125 W. PACIFIC, SUITE B-1  
 TELLURIDE, COLORADO 81435

Drawing path: dwg\Condo Unit C 04-15.dwg

Sheet1 of 2 Project #: 01132

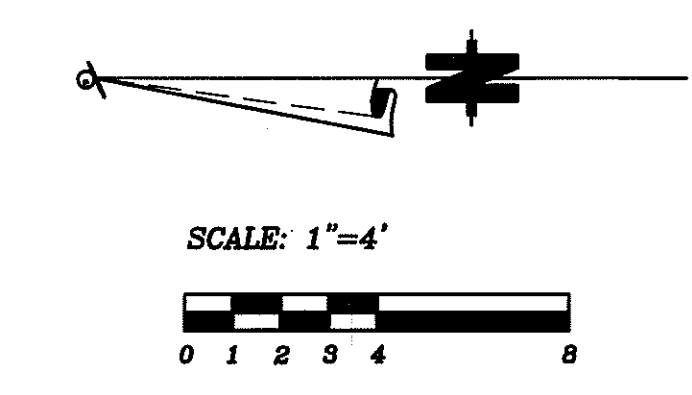

**LEGEND**  
G.C.E. = GENERAL COMMON ELEMENT  
L.C.E. = LIMITED COMMON ELEMENT  
--- DENOTES CHANGE IN CEILING HEIGHT (UPPER BOUNDARY)  
|| DENOTES UPWARD SLOPING CEILING

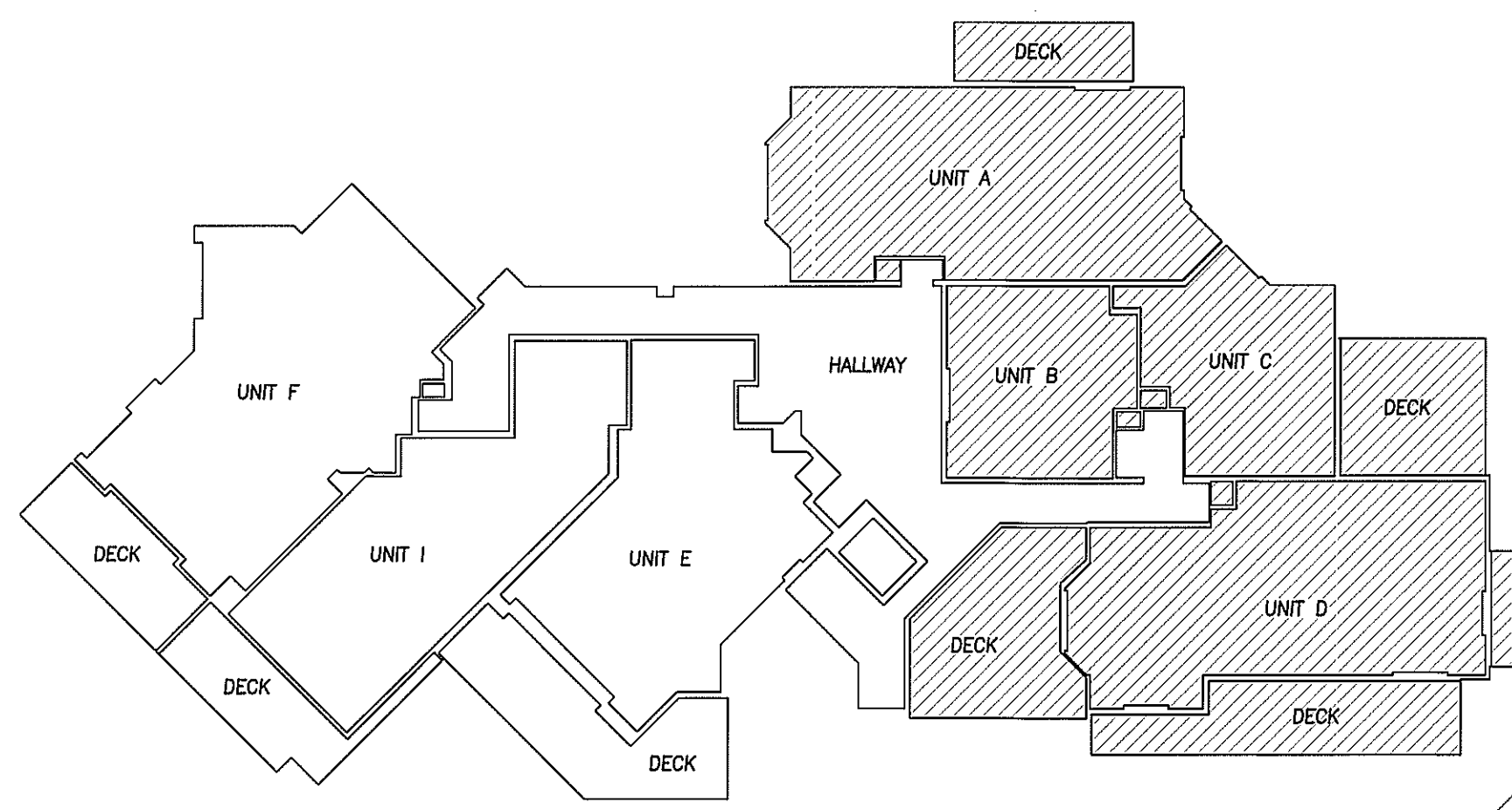
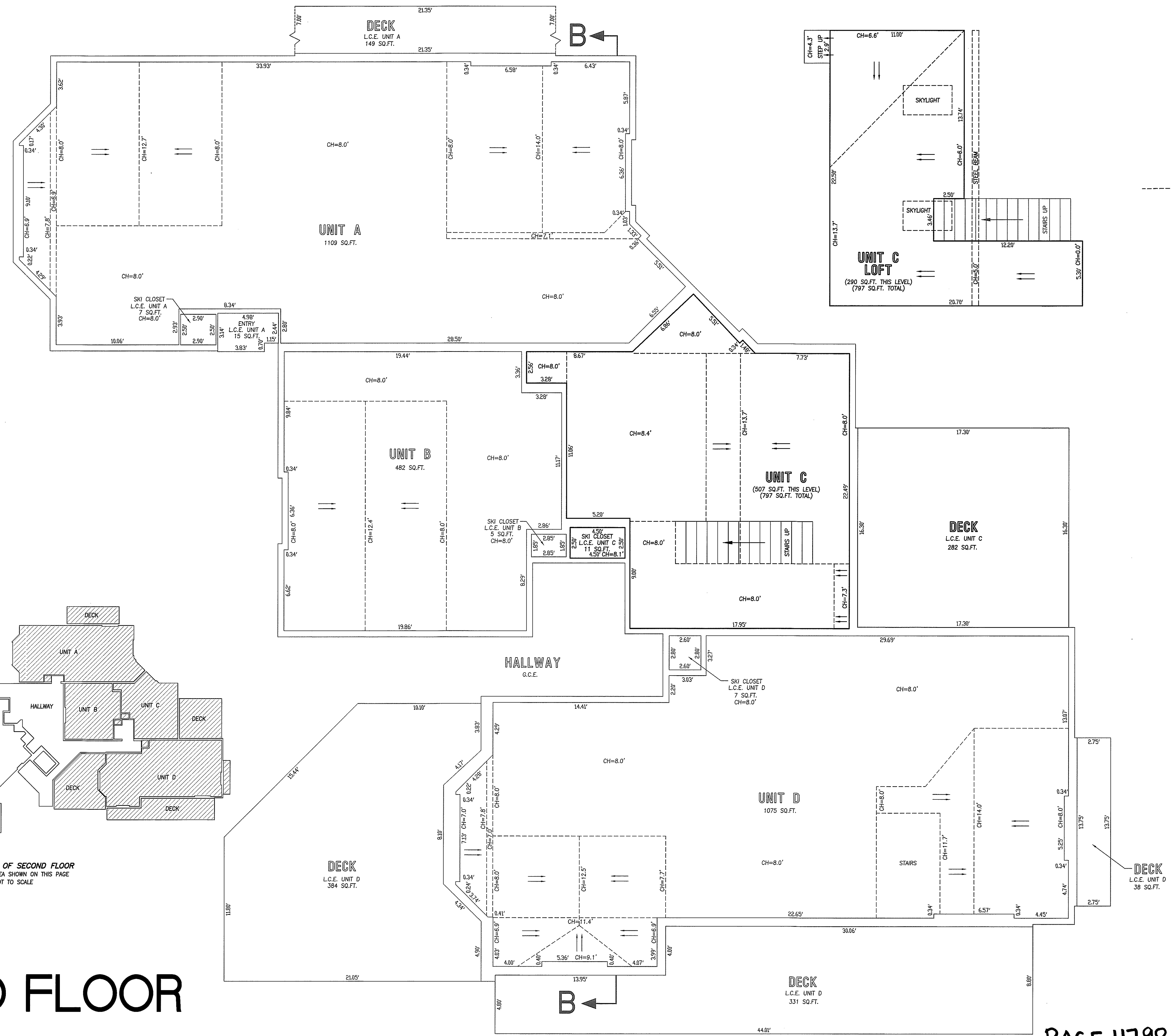

OVERVIEW OF SECOND FLOOR  
SHADED AREA SHOWN ON THIS PAGE  
NOT TO SCALE

# SECOND FLOOR

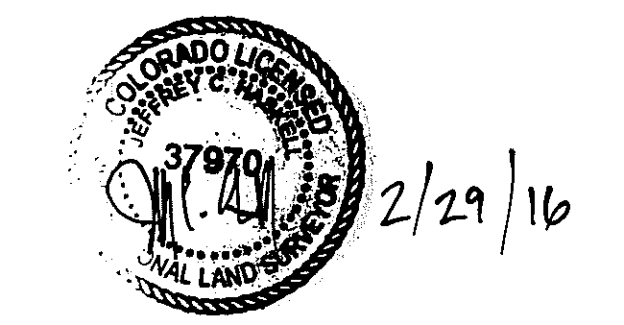

PAGE 4798

First Amendment to Le Chamonix Condominiums Amended and Restated Condominium Map,  
located on Lot 60R-AB, Town of Mountain Village.

Project Mgr:	JH	Rev.	description	date	by
Technician:	MC				
Checked by:	KV				
Start date:	04/01/2015				



970-728-6153 970-728-6050 fax  
P.O. BOX 1385  
125 W. PACIFIC, SUITE B-1  
TELLURIDE, COLORADO 81435



## DRB Members 2021 Appointed

Member	Original Date Appointed	Term Expiration	Regular/Alternate	
Dave Craige	5/1/2015	Apr-22	Regular	
Adam Miller	6/6/2019	Apr-22	Regular	took over regular seat 2020
Banks Brown	11/1/2010	Apr-22	Regular	12 years are up 2022
Catherine Jett	5/1/2019	Apr-22	Regular	
Dave Eckman	4/1/2009	Apr-21	Regular	12 years are up 2021
Greer Garner	4/1/2013	Apr-21	Regular	
Liz Caton	5/1/2015	Apr-21	Regular	
Scott Bennett	5/1/2020	Apr-21	Alternate	took over seat from Adam Miller
Ellen Kramer	6/6/2019	Apr-21	Alternate	