

**TOWN OF MOUNTAIN VILLAGE  
REGULAR DESIGN REVIEW BOARD MEETING AGENDA  
THURSDAY NOVEMBER 7, 2024, 10:00 AM  
MOUNTAIN VILLAGE TOWN HALL  
455 MOUNTAIN VILLAGE BLVD, MOUNTAIN VILLAGE, COLORADO  
TO BE HELD HYBRID THROUGH ZOOM:  
<https://us06web.zoom.us/j/89842973313>  
Meeting ID: 898 4297 3313**

Zoom participation in public meetings is being offered as a courtesy, however technical difficulties can happen, and the Town bears no responsibility for issues that could prevent individuals from participating remotely. Physical presence in Council chambers is recommended for those wishing to make public comments or participate in public hearings.

Agenda Item	Time	Min.	Presenter	Type	Item Description
1.	10:00	0	Chair	Chair	Call to Order
2.	10:00	2	Howe	Action	Reading and Approval of Summary of Motions of the October 3, 2024, Design Review Board Meeting.
3.	10:02	30	Perez/ Applicant	Quasi-Judicial	Consideration of a Design Review: Final Architecture Review for a new single-family detached condominium at Lot 649R, TBD Boulders Way Unit 10, pursuant to CDC Section 17.4.11.
4.	10:32	45	Nelson/ Applicant	Quasi-Judicial	Consideration of a Design Review: Initial Architecture and Site Review for a new 3-unit condominium at Lot 165-17R, 115 Cortina Drive Unit 17R, pursuant to CDC Section 17.4.11.
5.	11:17	10	Nelson/ Applicant	Quasi-Judicial	Review and Recommendation to Town Council regarding a Density Transfer and Rezone Application for Lot 908, TBD Victoria Drive, pursuant to CDC section 17.4.9 and 17.4.10.

**DESIGN REVIEW BOARD MINUTES  
TOWN OF MOUNTAIN VILLAGE  
REGULAR DESIGN REVIEW BOARD MEETING  
SEPTEMBER 5, 2024, 10:00 AM**

**Call to Order**

Chair **Brown** called the meeting of the Design Review Board DRB of the Town of Mountain Village to order at 10:00 a.m. on September 5, 2024.

**Attendance**

**The following Board members were present and acting:**

Scott Bennett (acting Chairman)  
David Craige  
Liz Newton  
Jim Austin (via Zoom)  
Adam Miller  
Ellen Kramer  
David Eckman (via Zoom – left after lunch)

**The following Board members were absent:**

Banks Brown  
Greer Garner

**Town Staff in attendance:**

Amy Ward – Community Development Director  
Drew Nelson – Senior Planner  
Claire Perez – Planner II (via Zoom)

**Public Attendance:**

Will Hentschel  
Andrew Brenner  
Scott Brenner  
Richard Thorpe  
Jolana Vanek  
Narcis Tudor

**Public Attendance via Zoom:**

**Item 2. Reading and Approval of Summary of Motions of the September 5, 2024, Design Review Board Meeting.**

On a **MOTION** by **Newton** and seconded by **Kramer** the DRB voted **unanimously** to approve the summary of motions of the September 5, 2024, Design Review Board meeting minutes.

**Item 3. Consideration of a Design Review: Final Architecture Review for a new single-family detached condominium at Lot 1 Unit 21, Knoll Estates Unit 2, TBD Fairway Dr, pursuant to CDC Section 17.4.11.**

Drew Nelson: Presented as Staff

Kristine Perpar: Presented as Applicant

Public Comment: None

On a **MOTION** by **Craige** and seconded by **Miller** the DRB voted **unanimously** to **approve** the Consideration of a Design Review: Final Architecture Review for a new single-family detached condominium at Lot 1 Unit 21, Knoll Estates Unit 2, TBD Fairway Dr, pursuant to CDC Section 17.4.11., based on the evidence provided in the staff memo of record dated September 24, 2024, and the findings of the meeting.

**Design Variation**

- 1) Building-Mounted Address Plaque

**DRB Specific Approval**

- 1) Grading in the General Easement

**With the following conditions:**

- 1) *Per CDC Section 17.3.9, Housing Impact Mitigation requirements for this development application are set at 75% as the application was first submitted in 2024.*
- 2) *The applicant shall work with Public Works and utility providers to finalize the utilities plan as a condition of approval prior to building permit.*
- 3) *The structure shall require a monitored NFPA 72 alarm system and monitored NFPA 13D sprinkler system.*
- 4) *A Knox Box for emergency access is recommended.*
- 5) *Per CDC 17.3.9 Housing Impact Mitigation Requirements for this development application are set at 75% since the application was submitted and deemed complete 2024.*

- 6) *Unenclosed accessory structures attached to buildings with habitable spaces and projections, such as decks, shall be protected by one of the following methods: Constructed with either non-combustible materials, heavy timber as specified in the (2018 IBC section 2304.11) or exterior grade ignition resistant materials as specified in the (2018 IBC section 2303.2). Or constructed so that all exposed structural members are enclosed with an approved one-hour assembly by the Building Official, or constructed in coordination with the Planning Department upon approval of a wildfire mitigation plan addressing defensible space criteria provided in CDC Section 17.6.1(A) – Fire Mitigation and Forestry Management. All appendages and projections regardless of method of construction shall provide a cleanable ground surface, as applicable. The fire mitigation approach will require a planning department sign off on the inspection record, prior to the framing inspection.*
- 7) *Prior to the Building Division conducting the required framing inspection, a four-foot 4' by eight-foot 8' materials board will be erected on site consistent with the review authority approval to show:*
- a. The stone, setting pattern and any grouting with the minimum size of four feet 4' by four feet 4';*
  - b. Wood that is stained in the approved color(s);*
  - c. Any approved metal exterior material;*
  - d. Roofing material(s); and*
  - e. Any other approved exterior materials*
- 8) *It is incumbent upon an owner to understand whether above grade utilities and town infrastructure (fire hydrants, electric utility boxes) whether placed in the right of way or general easement, are placed in an area that may encumber access to their lot. Relocation of such above grade infrastructure appurtenances will occur at the owner's sole expense and in coordination with the appropriate entity (fire department, SMPA, Town of Mountain Village) so that the relocated position is satisfactory.*

**Item 4. Consideration of a Design Review: Final Architecture Review for a new single-family detached condominium at Lot 649R, TBD Boulders Way Unit 10, pursuant to CDC Section 17.4.11.**

Claire Perez: Presented as Staff

Kristine Perpar and Daniel Oldmixon: Presented as Applicants

Public Comment: Jolana Vanek and Richard Thorpe

On a **MOTION** by **Kramer** and seconded by **Newton** the DRB voted **4-3** to **continue** (Bennett, Miller, and Austin opposed due to faith in the applicant to make requested changes) the Consideration of a Design Review: Final Architecture Review for a new single-family detached

condominium at Lot 649R, TBD Boulders Way, pursuant to CDC Section 17.4.11., based on the evidence provided in the staff memo of record dated September 19, 2024, and the findings of the meeting.

**Item 5. Consideration of a Design Review: Initial Architecture and Site Review for a new single-family home at Lot 1004BR, TBD Victoria Drive, pursuant to CDC Section 17.4.11.**

Claire Perez: Presented as Staff

Narcis Tudor: Presented as Applicant

Public Comment: None

On a **MOTION** by **Craige** and seconded by **Kramer** the DRB voted unanimously to **approve** the Consideration of a Design Review: Initial Architecture and Site Review for a new single-family home at Lot 1004BR, TBD Victoria Drive, pursuant to CDC Section 17.4.11., based on the evidence provided in the staff memo of record dated September 20, 2024, and the findings of the meeting.

**With the following conditions:**

- 1) *Prior to final review, the applicant shall modify the landscaping and fire mitigation plans to adhere to the CDC and the Forester's comments.*
- 2) *Prior to final review, the applicant shall provide the dimensions of the parking spaces.*
- 3) *Prior to final review, the applicant shall provide a light fixture for the address monument that meets CDC requirements.*
- 4) *Prior to final review, the applicant shall provide the dimensions of the retaining wall associated with the driveway.*
- 5) *Prior to final review, the applicant shall include iso foot candle model and full comprehensive lighting design with cut sheets of all fixtures in 8x10 format.*
- 6) *Prior to the issuance of a building permit, the town forester shall sign off on both the landscaping plan and fire mitigation plan.*
- 7) *Prior to the issuance of a building permit, the applicant shall field verify all utility locations.*
- 8) *Consistent with town building codes, Unenclosed accessory structures attached to buildings with habitable spaces and projections, such as decks, shall be constructed as either non-combustible, heavy timber or exterior grade ignition resistant materials such as those listed as WUIC (Wildland Urban Interface Code) approved products.*
- 9) *A monumented land survey shall be prepared by a Colorado public land surveyor to establish the maximum building height and the maximum average building height.*
- 10) *A monumented land survey of the footers will be provided prior to pouring concrete to determine there are no additional encroachments into the GE.*

- 11) *Prior to the Building Division conducting the required framing inspection, a four foot 4' by eight-foot 8' materials board will be erected on site consistent with the review authority approval to show:*
  - a. *The stone, setting pattern and any grouting with the minimum size of four feet 4' by four feet 4';*
  - b. *Wood that is stained in the approved color(s);*
  - c. *Any approved metal exterior material;*
  - d. *Roofing material(s); and*
  - e. *Any other approved exterior materials*
- 12) *It is incumbent upon an owner to understand whether above grade utilities and town infrastructure (fire hydrants, electric utility boxes) whether placed in the right of way or general easement, are placed in an area that may encumber access to their lot. Relocation of such above grade infrastructure appurtenances will occur at the owner's sole expense and in coordination with the appropriate entity (fire department, SMPA, Town of Mountain Village) so that the relocated position is satisfactory.*
- 13) *The applicant shall meet the following conditions of the Fire Marshall:*
  - a. *A monitored automatic sprinkler system shall be installed in accordance with NFPA 13D, 2018 IFC, and TFPD amended codes.*
  - b. *An interconnected monitored fire alarm system shall be installed in accordance with NFPA 72, 2018 IFC, and TFPD amended codes.*
  - c. *Monitored carbon monoxide detection shall be installed in accordance with 2018 IFC 915.2.1.*
  - d. *Address numbers shall be a minimum of 4 feet 6 inches from grade to the bottom of 6-inch numbers/letters with a reflective coating or outlined with a reflective coating.*
  - e. *Electric vehicle charging stations/outlets shall be installed in accordance with NFPA 70 and located within 5 feet of the garage door.*
- 14) *Per CDC 17.3.9 Housing Impact Mitigation Requirements for this development application are set at 75% since the application was submitted and deemed complete in 2024.*
- 15) *Prior to Final Architecture Review, the applicant must provide a full schematic and conceptual design of the ski bridge over the driveway.*
- 16) *Prior to Final Architecture Review, the applicant must provide a snow melt plan for both the auto court and roof system to address snow stacking and storage.*
- 17) *Prior to Final Architecture Review, the applicant must provide a construction mitigation plan accounting for Victoria Drive limitation with a nonconforming bridge.*
- 18) *Prior to Final Architecture Review, the applicant must provide stone calculations broken out for the structure and retaining walls.*

**Item 6. Lunch.**

**Item 7. Review and Recommendation to Town Council regarding a Density Transfer and Rezone Application for Lot 644, TBD Adams Ranch Rd (Meadowlark), pursuant to CDC section 17.4.9 and 17.4.10.**

Claire Perez: Presented as Staff

Michelle Haynes: Presented as Applicant

Public Comment:

On a **MOTION** by **Craige** and seconded by **Newton** the DRB voted **unanimously** to **approve** the Review and Recommendation to Town Council regarding a Density Transfer and Rezone Application for Lot 644, TBD Adams Ranch Rd (Meadowlark), pursuant to CDC section 17.4.9 and 17.4.10., based on the evidence provided in the staff memo of record dated September 20, 2024, and the findings of this meeting.

**Item 8. Review and Recommendation to Town Council regarding a Density Transfer and Rezone Application for Lots 1001 and 1005, 415 Mountain Village Blvd, pursuant to CDC sections 17.4.9 and 17.4.10.**

Claire Perez: Presented as Staff

Michelle Haynes: Presented as Applicant

Public Comment:

On a **MOTION** by **Kramer** and seconded by **Newton** the DRB voted **unanimously** to **approve** the Review and Recommendation to Town Council regarding a Density Transfer and Rezone Application for Lots 1001 and 1005, 415 Mountain Village Blvd, pursuant to CDC section 17.4.9 and 17.4.10., based on the evidence provided in the staff memo of record dated September 20, 2024, and the findings of this meeting.

**Item 9. Review and Recommendation to Town Council regarding a CDC Amendment to CDC Section 17.5.14 Private Art, pursuant to CDC Section 17.1.7**

Drew Nelson: Presented as Staff

N/A: Presented as Applicant

Public Comment:

On a **MOTION** by **Newton** and seconded by **Miller** the DRB voted **unanimously** to **approve** the Review and Recommendation to Town Council regarding a CDC Amendment to CDC Section 17.5.14 Private Art, pursuant to CDC Section 17.1.17., based on the evidence provided in the staff memo of record dated September 24, 2024, and the findings of this meeting.

**Item 10. Adjourn**

The DRB voted **unanimously** to adjourn the October 3, 2024, Design Review Board Meeting at 12:34PM.

Prepared and submitted by,

Erin Howe, Planning Technician

DRAFT





**PLANNING & DEVELOPMENT SERVICE  
PLANNING DIVISION**

455 Mountain Village Blvd.  
Mountain Village, CO 81435  
(970) 728-1392  
Agenda Item 3

---

**TO:** Mountain Village Design Review Board  
**FROM:** Claire Perez, Planner II  
**FOR:** Design Review Board Public Hearing; November 7, 2024  
**DATE:** October 23, 2024  
**RE:** Staff Memo – Final Architecture Review (FAR) for Lot 649R unit 10, TBD Boulders Way.

---

**APPLICATION OVERVIEW: New Single-Family Home on Lot 649R  
Unit 10**

**PROJECT GEOGRAPHY**

**Legal Description:** UNIT 10 THE BOULDERS AT MOUNTAIN VILLAGE LOCATED ON LOT 649R TOWN OF MOUNTAIN VILLAGESAN MIGUEL COUNTY COLORADO ACC TO THE COMMON INTEREST COMMUNITY MAP REC PLAT BK 1 PG 3096 AND DECS AT 354564 REC JAN 24 2003 ALONG WITH ACCESS AND UTILITY EASEMENT AT 354565 AND UTILITY EASEMENT AT 354566

**Address:** TBD Boulders Way

**Applicant/Agent:** Kristine Perpar, Shift Architects

**Owner:** Daniel Oldmixon

**Zoning:** Multi-family

**Existing Use:** Vacant

**Proposed Use:** Single-Family Detached  
Condominium

**Lot Size:** 2,282 sf, 0.052 acres

**Adjacent Land Uses:**

- **North:** Multi-family
- **South:** Passive Open-Space
- **East:** Multi-family
- **West:** Multi-family



*Figure 1: Vicinity Map*

## **ATTACHMENTS**

Exhibit A: Architectural Plan Set

Exhibit B: Staff/Public Comment

**Case Summary:** Kristine Perpar of Shift Architects is requesting Design Review Board (DRB) approval of a Final Architectural Review (FAR) for a new single-family detached condominium on Lot 649R Unit 10, TBD Boulders Way. The lot is approximately 0.052 acres, 2,282 sf, and is zoned multi-family. The proposed design consists of a three-story structure. The overall square footage of the home is approximately 2,925 gross square feet and provides 1 interior parking space within the proposed garage. The property is located in the Boulders neighborhood. The proposal includes a 681 square foot Accessory Dwelling Unit (ADU) in the basement. ADU's are permitted in detached condominium units.

The proposed development requires Design Review Board specific approvals for several setback encroachments and tandem parking.

This DRB reviewed this case at the October 3, 2024, regular DRB meeting and continued the discussion to the November 7, 2024 regular DRB meeting. The Board requested that the applicant remove an encroachment of a window well in the setback, increase the stone percentage, and provide more details for the construction mitigation plan. In response to the DRB comments, the applicant has provided revisions to the home. The applicant outlined the changes made in their narrative.

**Applicable CDC Requirement Analysis:** The applicable requirements cited may not be exhaustive or all-inclusive. The applicant is required to follow all requirements even if an applicable section of the CDC is not cited. ***Please note that Staff comments will be indicated by italicized Text.***

*Table 1*

<b><u>CDC Provision</u></b>	<b><u>Requirement</u></b>	<b><u>Proposed</u></b>
<b>Maximum Building Height</b>	40' (gable) Maximum	38.84'
<b>Maximum Avg. Building Height</b>	35' (gable) Maximum	32.90'
<b>Maximum Lot Coverage</b>	To extent of building envelope (1,483 sf)	937 sf
<b>General Easement Setbacks</b>	No encroachment	Setback Encroachment
<b>Roof Pitch</b>		
Primary		8:12
Secondary		2 1/2:12
<b>Exterior Material</b>		
Stone	35% minimum	35%
Windows/Doors	40% maximum	15%
<b>Parking</b>	2 enclosed	1 interior/ 2 exterior

### **DRB Specific Approval:**

1. Setback Encroachments – Parking, stepping stones, and pavers
2. Tandem Parking
3. Materials – Composite Wood

*Please note, this memo addresses only the design variations and specific approvals that are being requested, as well as any changes or additional information provided since the Initial Architectural and Site Review. For more information regarding the details of the Initial Architectural and Site Review please see staff memo of record dated July 21, 2024.*

## **Chapter 17.3: ZONING AND LAND USE REGULATIONS**

### **17.3.12: Building Height Limits**

*Staff: Criteria met.*

### **17.3.14: General Easement Setbacks**

There is no General Easement on site. Lot 649R Unit 10 has an established building envelope. Lot 649R Unit 10 is burdened by a 5' side setback as well as a 10' setback adjacent to Boulders Way, and a 3' setback on the back of the lot. The CDC provides that setbacks be maintained in a natural, undisturbed state to provide buffering to surrounding land uses. The CDC does provide for some development activity within setbacks such as driveways, ski access, natural landscaping, utilities, address monuments, and fire mitigation.

*Staff: The proposal includes several setback encroachments that fall into the above category of permitted development activity including the following:*

- *Utilities: The applicant has provided a utility plan for Lot 649R-10 demonstrating the proposed locations of utility lines and connections. It will be necessary for these to cross the front and side GE.*

*The proposal also includes some setback encroachments requiring specific DRB approval:*

- *Exterior parking in front setback.*
- *Paving stones for parking in front and side setback.*
- *Landscape steppingstones in side setback. The steppingstones provide access to the ADU.*

*The HOA has approved the above setbacks encroachments.*

## **Chapter 17.5: DESIGN REGULATIONS**

### **17.5.4: Town Design Theme**

The Town of Mountain Village has established design themes aimed at creating a strong image and sense of place for the community. Due to the fragile high alpine environment, architecture and landscaping shall be respectful and responsive to the tradition of alpine design – reflecting elements of alpine regions while blending influences that visually tie the town to mountain buildings. The town recognizes that architecture will continue to evolve and create a regionally unique mountain vernacular, but these evolutions must continue to embrace nature and traditional style in a way that respects the design context of the neighborhoods surrounding the site.

*Staff: The proposed home features the traditional material palette of the Mountain Village – Stone, composite Wood, and Metal. These materials are capable of withstanding the high alpine environment. Composite wood requires specific approval by the DRB.*

#### **17.5.5: Building Siting Design**

The CDC requires that any proposed development blend into the existing landforms and vegetation.

*Staff: The structure mostly adheres to the established building envelope with the exception of a few setback encroachments. The building design has been revised since the previous review to reduce the number of encroachments. The applicant revised the layout of the ADU to remove the window well from the northern setback per the DRB's comments at the previous meeting. Staff finds that the proposed home blends into the existing landforms and vegetation.*

#### **17.5.6: Building Design**

*Staff: The home is a mountain modern home that incorporates grey Flint Sawn Stone in a horizontal arrangement, Mountain Sage lap siding, black corrugated metal roofing, and black clad windows. The fascia is black metal to match the roof. The soffit material will match the cedar decking. The first level of the home has been revised so that it is wrapped in stone. This increased the overall stone percentage total to 35%. The applicant is no longer asking for a design variation for being under the minimum requirement.*

#### **17.5.7: Grading and Drainage Design**

*Staff: The grading plan shows positive drainage away from the home with no re-grading necessary. The grading plan was revised to include an angular rip rap at the back of the lot where it is above 30% in slope.*

#### **17.5.8: Parking Regulations**

*Staff: The applicant has shown one interior parking space and two exterior spaces on their architectural site plan. The exterior parking spaces are separated by landscape steppingstones in the center. The parking configuration as shown will require DRB specific approval of tandem parking. Due to the limited size of the lot, the applicant has proposed a portion of the exterior spaces within the front and side setback. The eastern parking space is proposed as a paver ribbon style driveway. The setback encroachments require specific approval from the DRB.*

#### **17.5.9: Landscaping Regulations**

*Staff: The applicant has provided a landscape plan on Sheet A1.2. There is no existing vegetation on site. The applicant has proposed 8 Woods Rose bushes on the site. The landscaping plan needs to be revised to include a tree planting detail that shows the proper steps required in planting trees and shrubs.*

*The plan also needs a note that states that the burlap and wire basket must be removed to at least the top 12 -16 inches of the root ball. The plan should be amended per the Forester's comments prior to building permit.*

#### **17.5.11: Utilities**

*Staff: The applicant provided a utility plan on Sheet C2. The plan shows the sewer and water lines crossing the front setback to connect in Boulders Way. The electric and gas lines will cross the side setback to connect to an existing Pedestal to the east. Staff sees no issues with this plan. The applicant will need to field verify the proposed locations.*

#### **17.5.12: Lighting Regulations**

*Staff: A lighting plan has been provided demonstrating the specific types and locations of the proposed lighting. The applicant has proposed utilizing a recessed can, sconce, and*

*step light. The fixtures proposed are dark sky and CDC compliant. Staff finds the criteria met.*

#### **17.5.13: Sign Regulations**

*Staff: A wall mounted address monument is shown on Sheet A4.1. The height of the address monument has been revised to meet the CDC requirement for 54" from finished grade. Staff finds the criteria met.*

### **Chapter 17.6: SUPPLEMENTARY REGULATIONS**

#### **17.6.1: Environmental Regulations**

*Staff: Fire Mitigation and Forestry Management: A fire mitigation plan was provided on Sheet A1.2. Due to the small lot size, Zone 1 fire mitigation encompasses the entire lot. The fire mitigation plan adheres to CDC requirements.*

#### **17.6.6: Roads and Driveway Standards**

*Staff: The applicant has proposed a section of concrete driveway, with pavers to the left of the driveway. The width of the concrete driveway is shown at 17.91'x11'. The minimum width required by the CDC is 12. The width should be revised prior to building permit CDC requirements.*

#### **17.6.8: Solid Fuel Burning Device Regulations**

*Staff: The applicant has indicated that the proposed home does not include any solid fuel burning devices.*

### **Chapter 17.7: BUILDING REGULATIONS**

#### **17.7.19: Construction Mitigation**

*Staff: The construction mitigation plan shows required material staging, dumpster, bear-proof trash receptacles, and a port a toilet. The plan should be revised to include silt fencing or storm water management devices on the downhill side of the lot. There is only one parking space indicated on the plan. The construction mitigation plan narrative notes that parking and material staging will be on Units 2 and 17 as allowed. Overflow parking will be at the Big Billie's parking lot. The applicant will need to provide authorization for the use of the lots and coordinate parking in the Big Billie's lots with the Town.*

**Staff Recommendation:** Staff recommends the DRB approve the Final Architecture Review for Lot 649R Unit 10, TBD Boulders Way based on the findings and CDC requirements listed in the staff memo of record.

***Staff Note: It should be noted that reasons for approval or rejection should be stated in the findings of fact and motion.***

#### **Proposed Motion:**

If the DRB deems this application to be appropriate for approval, Staff requests said approval condition the items listed below in the suggested motion.

I move to approve the Final Architecture Review for a new single-family home located at Lot 649R Unit 10, based on the evidence provided within the Staff Report of record dated October 23, 2024, with the following design variations and specific approvals:

DRB Specific Approval:

- 1) Setback Encroachments
- 2) Tandem Parking
- 3) Materials –Composite Wood

And, with the following conditions:

- 1) Prior to building permit, the applicant shall revise the construction mitigation plan to include storm water management devices on the downhill slope
- 2) Prior to building permit, the applicant shall revise the width of the driveway to meet CDC requirements.
- 3) Prior to the issuance of a building permit, the landscape plan shall be amended per the Town Forester's comments.
- 4) Prior to the issuance of a building permit, the applicant shall field verify all utility locations.
- 5) Consistent with town building codes, Unenclosed accessory structures attached to buildings with habitable spaces and projections, such as decks, shall be constructed as either non-combustible, heavy timber or exterior grade ignition resistant materials such as those listed as WUIC (Wildland Urban Interface Code) approved products.
- 6) A monumented land survey shall be prepared by a Colorado public land surveyor to establish the maximum building height and the maximum average building height.
- 7) A monumented land survey of the footers will be provided prior to pouring concrete to determine there are no additional encroachments into the GE.
- 8) Prior to the Building Division conducting the required framing inspection, a four-foot (4') by eight-foot (8') materials board will be erected on site consistent with the review authority approval to show:
  - a. The stone, setting pattern and any grouting with the minimum size of four feet (4') by four feet (4');
  - b. Wood that is stained in the approved color(s);
  - c. Any approved metal exterior material;
  - d. Roofing material(s); and
  - e. Any other approved exterior materials
- 9) It is incumbent upon an owner to understand whether above grade utilities and town infrastructure (fire hydrants, electric utility boxes) whether placed in the right of way or general easement, are placed in an area that may encumber access to their lot. Relocation of such above grade infrastructure appurtenances will occur at the owner's sole expense and in coordination with the appropriate entity (fire department, SMPA, Town of Mountain Village) so that the relocated position is satisfactory.
- 10) The applicant shall meet the following conditions of the Fire Marshall:
  - a. A monitored automatic sprinkler system shall be installed in accordance with NFPA 13D, 2018 IFC, and TFPD amended codes.
  - b. An interconnected monitored fire alarm system shall be installed in accordance with NFPA 72, 2018 IFC, and TFPD amended codes.
  - c. Monitored carbon monoxide detection shall be installed in accordance with 2018 IFC 915.2.1.
  - d. Address numbers shall be a minimum of 4 feet 6 inches from grade to the bottom of 6-inch numbers/letters with a reflective coating or outlined with a reflective coating.
  - e. Electric vehicle charging stations/outlets shall be installed in accordance with NFPA 70 and located within 5 feet of the garage door.

Shift Architects

Date: October 23, 2024

By: Kristine Perpar, Architect

Property address:  
Boulder Lot 10  
Telluride, CO 81435

**Sent to:**

Town of Mountain Village and DRB Board

**Re:** Revision for Final Plan Review

1. Revised ADU Layout, remove window wells from setback.
2. Increased the stone to 35%
3. Dimension the driveway
4. Revised Construction Mitigation
5. Revised Civil drawings regarding drainage

Please let me know if you have any questions or concerns.

Sincerely,



Kristine Perpar

## GENERAL NOTES:

### CONTRACT DOCUMENTS:

CONTRACT DOCUMENTS CONSIST OF THE AGREEMENT, GENERAL CONDITIONS, SPECIFICATIONS, DETAIL BOOK AND DRAWINGS, WHICH ARE COOPERATIVE AND CONTINUOUS. WORK INDICATED OR REASONABLY IMPLIED IN ANY ONE OF THE DOCUMENTS SHALL BE SUPPLIED AS THOUGH FULLY COVERED IN ALL. ANY DISCREPANCIES BETWEEN THE PARTS SHALL BE REPORTED TO THE ARCHITECT PRIOR TO THE COMMENCEMENT OF WORK. THESE DRAWINGS ARE PART OF THE CONTRACT DOCUMENTS FOR THIS PROJECT. THESE DRAWINGS ARE THE GRAPHIC ILLUSTRATION OF THE WORK TO BE ACCOMPLISHED. ALL DIMENSIONS NOTED TAKE PRECEDENCE OVER SCALED DIMENSIONS. DIMENSIONS NOTES WITH "N.T.S." DENOTES NOT TO SCALE.

### ORGANIZATION:

THE DRAWINGS FOLLOW A LOGICAL, INTERDISCIPLINARY FORMAT: ARCHITECTURAL DRAWINGS (A SHEETS), CIVIL DRAWINGS (C SHEETS), STRUCTURAL (S SHEETS), MECHANICAL AND PLUMBING (M SHEETS), ELECTRICAL (E SHEETS) AND LIGHTING (LTG SHEETS).

### CODE COMPLIANCE:

ALL WORK, MATERIALS AND ASSEMBLIES SHALL COMPLY WITH APPLICABLE STATE AND LOCAL CODES, ORDINANCES AND REGULATIONS. THE CONTRACTOR, SUBCONTRACTORS AND JOURNEYMEN OF THE APPROPRIATE TRADES SHALL PERFORM WORK TO THE HIGHEST STANDARDS OF CRAFTSMANSHIP AND IN ACCORDANCE WITH AIA DOCUMENT A201-SECTION 3. THE BUILDING INSPECTOR SHALL BE NOTIFIED BY THE CONTRACTOR WHEN THERE IS NEED OF INSPECTION AS REQUIRED BY THE INTERNATIONAL BUILDING CODE OR ANY LOCAL CODE OR ORDINANCE.

### INTENT:

THESE DOCUMENTS ARE INTENDED TO INCLUDE ALL LABOR, MATERIALS, EQUIPMENT AND SERVICES REQUIRED TO COMPLETE THE WORK DESCRIBED HEREIN.

### COORDINATION:

THE CONTRACTOR SHALL CAREFULLY STUDY AND COMPARE THE DOCUMENTS, VERIFY ACTUAL CONDITIONS AND REPORT ANY DISCREPANCIES, ERRORS OR OMISSIONS TO THE ARCHITECT IN A TIMELY MANNER. THE ARCHITECT SHALL CLARIFY OR PROVIDE REASONABLE ADDITIONAL INFORMATION REQUIRED FOR SUCCESSFUL EXECUTION. THE CONTRACTOR SHALL VERIFY AND COORDINATE ALL OPENINGS THROUGH FLOORS, CEILINGS AND WALLS WITH ALL ARCHITECTURAL, INTERIOR, STRUCTURAL, MECHANICAL AND PLUMBING, ELECTRICAL AND LIGHTING DRAWINGS. CONTRACTOR WILL ASSUME RESPONSIBILITY OF ITEMS REQUIRING COORDINATION AND RESOLUTION DURING THE BIDDING PROCESS.

### SUBSTITUTIONS:

ANY MATERIALS PROPOSED FOR SUBSTITUTION OF THOSE SPECIFIED OR THE CALLED-OUT-BY-TRADE-NAME IN THESE DOCUMENTS SHALL BE PRESENTED TO THE ARCHITECT FOR REVIEW. THE CONTRACTOR SHALL SUBMIT SAMPLES WHEN REQUIRED BY THE ARCHITECT AND SUCH SAMPLES SHALL BE REVIEWED BY THE ARCHITECT BEFORE THE WORK IS PERFORMED. WORK MUST CONFORM TO THE REVIEWED SAMPLES. ANY WORK WHICH DOES NOT CONFORM SHALL BE REMOVED AND REPLACED WITH WORK WHICH CONFORMS AT THE CONTRACTOR'S EXPENSE. SUBCONTRACTORS SHALL SUBMIT REQUESTS FOR REVIEW THROUGH THE GENERAL CONTRACTOR WHEN WORK IS LET THROUGH HIM OR HER. REQUIRED VERIFICATION AND SUBMITTALS TO BE MADE IN ADEQUATE TIME AS NOT TO DELAY WORK IN PROGRESS.

### SHOP DRAWINGS:

SHOP DRAWINGS SHALL BE SUBMITTED TO THE ARCHITECT FOR HIS OR HER REVIEW WHERE CALLED FOR ANYWHERE IN THESE DOCUMENTS. REVIEW SHALL BE MADE BY THE ARCHITECT BEFORE WORK IS BEGUN, AND WORK SHALL CONFORM TO THE REVIEWED SHOP DRAWINGS, SUBJECT TO REPLACEMENT AS REQUIRED IN PARAGRAPH "SUBSTITUTIONS" ABOVE.

### SAFETY & PROTECTION OF WORK:

THE CONTRACTOR SHALL BE RESPONSIBLE FOR THE SAFETY AND CARE OF ADJACENT PROPERTIES DURING CONSTRUCTION FOR COMPLIANCE WITH FEDERAL AND STATE O.S.H.A. REGULATIONS, AND FOR THE PROTECTION OF ALL WORK UNTIL IT IS DELIVERED COMPLETED TO THE OWNER.

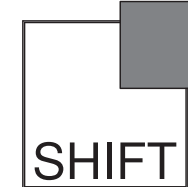

P.O. Box 3206  
100 W. Colorado Suite 211  
Telluride, Colorado 81435  
p 970-728-8145  
kristine@shift-architects.com  
www.shift-architects.com

PROJECT ISSUE DATE:  
10.14.24 REVISED FINAL DRB  
SUBMITTAL

## PROJECT CODE INFORMATION

ZONING:	MULTI-FAMILY
SUBDIVISION:	BOULDER ESTATES
BUILDING CODE:	IRC 2018 AND ALL APPLICABLE CODES AS REQUIRED BY THE TOWN OF MOUNTAIN VILLAGE
DESIGN REQUIREMENTS:	DECLARATION AND BOULDER ESTATES DESIGN COVENANTS IN ADDITION TO ANY REQUIREMENTS BY THE TOWN OF MOUNTAIN VILLAGE
DESCRIPTION:	MULTI-STORY DWELLING
OCCUPANCY CLASSIFICATION:	R-3
AUTOMATIC FIRE SPRINKLER:	NOT REQUIRED
FIRE RESISTIVE RATING:	GARAGE - 1 HR MECHANICAL - 1 HR

## PROJECT INFORMATION

TYPE OF UNIT:	SINGLE FAMILY HOME	MAX BUILDING HEIGHT: ALLOWABLE	40'-0" (35'-0" + 5'-0" GABLE RIDGE, CDC TABLE 3-3 FOOTNOTE 1)
GROSS FLOOR AREA:		PROPOSED	38.84'
LIVING		MAX AVERAGE HEIGHT: ALLOWABLE	35'-0" (30'-0" + 5'-0" GABLE RIDGE, CDC TABLE 3-3 FOOTNOTE 1)
BASEMENT	681 SF	PROPOSED	32.90'
GROUND LEVEL	483 SF	PARKING REQUIRED:	3 SPACES PROVIDED (1 ENCLOSED IN GARAGE) (2 SURFACE)
MAIN LEVEL	722 SF		
UPPER LEVEL	761 SF		
TOTAL:	<u>2,647 SF</u>		
GARAGE	278 SF		
TOTAL:	<u>2925 SF</u>		
LOT AREA:	2282.01 SF		
BUILDING FOOTPRINT:			
ALLOWABLE	1,483.30 SF		
PROPOSED	756 SF		

## SHEET INDEX

<b>GENERAL</b>	
G1.0	COVER SHEET
<b>SURVEY</b>	
0	SURVEY / EXISTING CONDITIONS
<b>CIVIL</b>	
C1	NOTES
C2	SITE DRAINAGE AND UTILITY PLAN
C3	CONSTRUCTION MITIGATION PLAN
<b>ARCHITECTURAL</b>	
A1.1	ARCHITECTURAL SITE PLAN
A1.2	LANDSCAPE PLAN
A3.1	FLOOR PLANS
A3.2	FLOOR & ROOF PLAN
A4.1	PROPOSED ELEVATIONS
A4.2	PROPOSED ELEVATIONS
A4.3	ELEVATION HEIGHT CALCS
A4.4	ELEVATION HEIGHT CALCS
A4.5	COLORIZED PERSPECTIVE
A4.6	COLORIZED PERSPECTIVE
A5.1	BUILDING SECTION
A5.2	BUILDING SECTION
A8.1	DOOR & WINDOW SCHEDULE
<b>LIGHTING</b>	
LTG1.1	LIGHTING PLANS
LTG1.2	LIGHTING PLAN

## VICINITY MAP

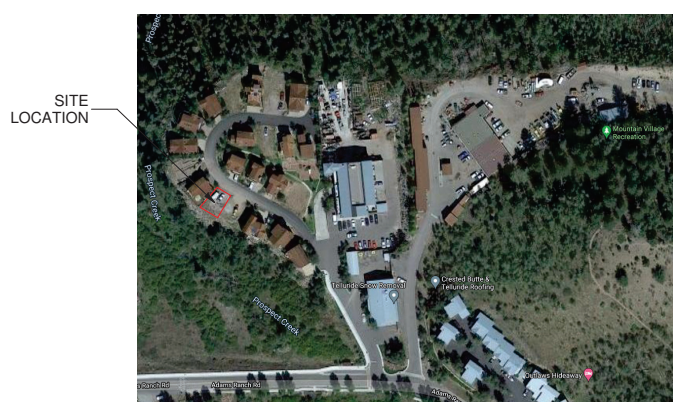

## PROJECT TEAM

<b>OWNER:</b>	<b>SURVEYOR:</b>	<b>MECHANICAL:</b>
DANIEL OLDMIXON PO BOX 99 TELLURIDE, CO 81435 P. 970.708.9515 DANIEL@OLDMIXONCO.COM	FOLEY ASSOCIATES, INC. 125 W. PACIFIC, SUITE B-1 P.O. BOX 1385 TELLURIDE, CO 81435 P. 970.728.6153 F. 970.728.6050	TBD
<b>ARCHITECT:</b>	<b>CIVIL:</b>	<b>LANDSCAPING:</b>
SHIFT ARCHITECTS KRISTINE PERPAR - ARCHITECT 100 WEST COLORADO STE. 211 TELLURIDE, CO 81435 P. 970.275.0263 kristine@shift-architects.com	UNCOMPAGRE ENGINEERING LLC DAVID BALLODE P.E. PO BOX 3945 TELLURIDE, CO 81435 P. 970.729.0683 dballode@msn.com	SHIFT ARCHITECTS KRISTINE PERPAR - ARCHITECT 100 WEST COLORADO STE. 211 TELLURIDE, CO 81435 P. 970.275.0263 kristine@shift-architects.com
<b>GENERAL CONTRACTOR:</b>	<b>STRUCTURAL:</b>	
OLDMIXON CONSTRUCTION DANIEL OLDMIXON PO BOX 99 TELLURIDE, CO 81435 P. 970.708.9515 DANIEL@OLDMIXONCO.COM	ALPINE EDGE ENGINEERING LLC MATTHEW D. HEPP, P.E. 605 RIVER PARK DR. RIDGWAY, CO 81432 matthewheppeng@gmail.com	

SERENITY MV

Unit-10, Boulders Way, Mountain Village  
Telluride, CO 81435, USA

COVER SHEET

SHEET NUMBER

G1.0

10/14/2024 2:04:48 PM

©shift architects



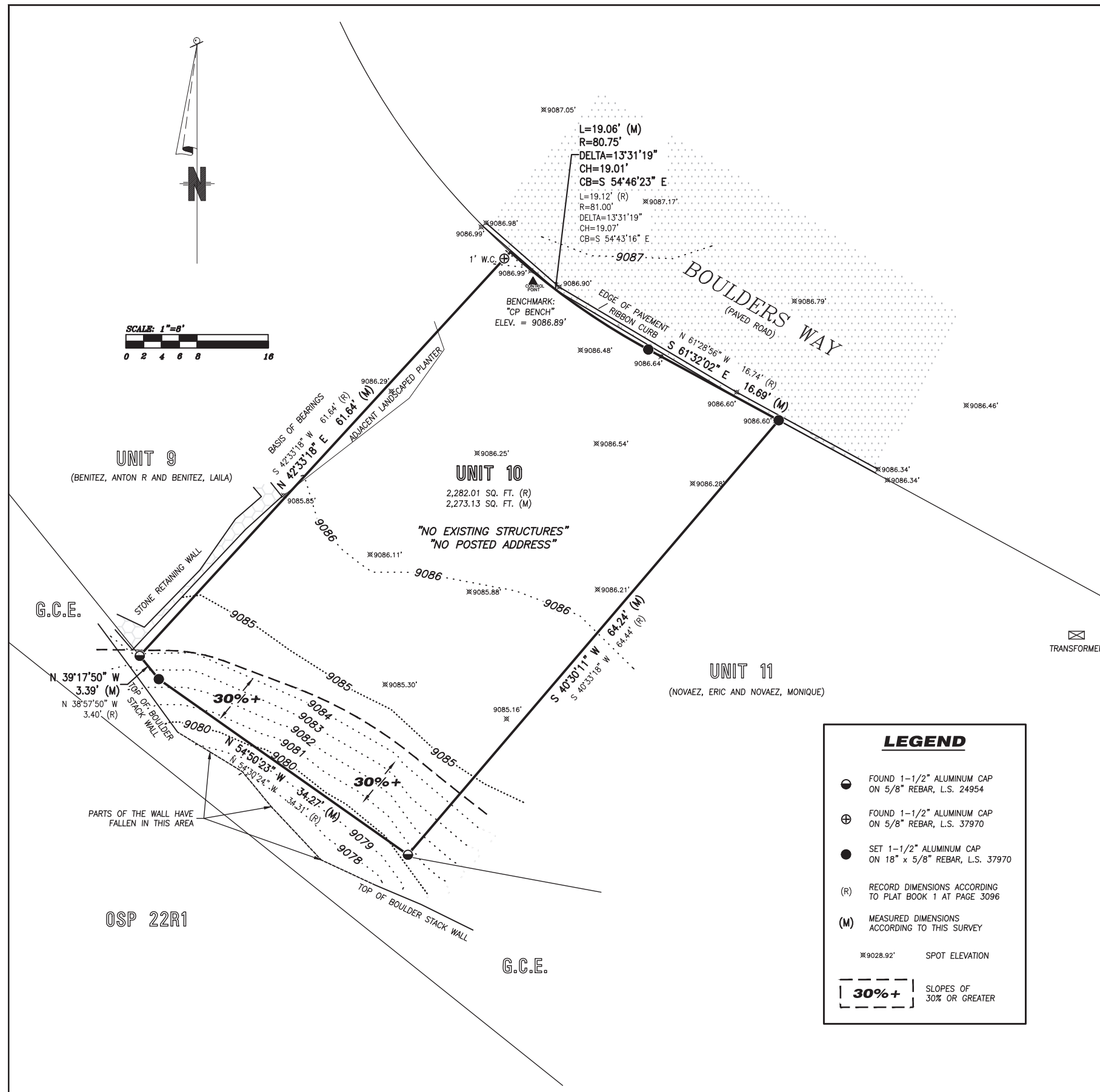

This Existing Conditions Plan Unit 10, The Boulders at Mountain Village, was field surveyed in August of 2021 under the direct responsibility, supervision and checking of Jeffrey C. Haskell of Foley Associates, Inc., being a Colorado Licensed Surveyor. It does not constitute a Land Survey Plat or Improvement Survey Plat as defined by section 38-51-102 C.R.S.

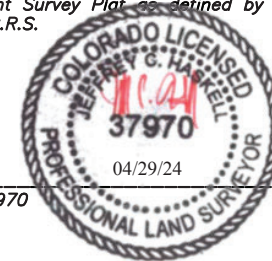

P.L.S. NO. 37970 Date

**PROPERTY DESCRIPTION:**

UNIT 10, THE BOULDERS AT MOUNTAIN VILLAGE, ACCORDING TO THE PLAT RECORDED JANUARY 24, 2003 IN PLAT BOOK 1 AT PAGE 3096, AND AS DEFINED AND DESCRIBED IN THE DECLARATION FOR THE BOULDERS AT MOUNTAIN VILLAGE RECORDED JANUARY 24, 2003 UNDER RECEPTION NO. 354564,

COUNTY OF SAN MIGUEL, STATE OF COLORADO.

**NOTES:**

- Easement research and property description from Land Title Guarantee Company, Order Number TLR86011806, dated July 8, 2021 at 5:00 P.M.
- According to FEMA Flood Insurance Rate Map 080168, Panel Number 0291 D, dated September 30, 1992, this parcel is within Zone X; Areas determined to be outside 500-year flood plain.
- Benchmark: "CP BENCH" as shown hereon with an assumed elevation of 9086.89 feet.
- Contour interval is one foot.
- BASIS OF BEARINGS: Found monuments along the Western boundary of Unit 10, as shown hereon, assumed to have the record bearing of N 42°33'18" E according to Plat Book 1 at page 3096.
- Slopes steeper than 30% exist on Unit 10 as shown hereon.
- The utilities shown hereon are based on visible infrastructure and utility locates should be performed by respective providers prior to construction.
- No trees greater than 4" in diameter exist on Unit 10.
- No known wetlands exist on Unit 10.
- NOTICE: According to Colorado law, you must commence any legal action based upon any defect in this survey within three years after you first discover such defect. In no event may any action based upon any defect in this survey be commenced more than ten years from the date of the certification shown hereon.

**Existing Conditions Plan**

Unit 10, The Boulders at Mountain Village,  
located within Section 33, T.43N., R.9W., N.M.P.M., San Miguel County, Colorado

Project Mgr: JH  
Technician: FO/MC  
Checked by:  
Start date: 08 / 2021



970-728-6153 970-728-6050 fax  
PO Box 1385  
125 W. Pacific Ave., Suite B-1  
Telluride, Colorado, 81435

Drawing path: dwg\21033 ECP 08-21 (ADJUSTED ELEV).dwg Sheet 1 of 1 Project #: 21033

GENERAL CIVIL ENGINEERING NOTES:

1. THE EXISTING UTILITY LINES SHOWN ON THE PLANS ARE APPROXIMATE. AT LEAST TWO (2) FULL WORKING DAYS PRIOR TO COMMENCING CONSTRUCTION, THE CONTRACTOR SHALL CONTACT THE UTILITY NOTIFICATION CENTER OF COLORADO @ 1-800-922-1987 OR 811 TO GET ALL UTILITIES LOCATED. IF ANY OF THESE UNDERGROUND UTILITIES ARE IN CONFLICT WITH THE CONSTRUCTION PLANS, THE CONTRACTOR SHALL NOTIFY THE ENGINEER AND WORK WITH THE ENGINEER TO FIND A SOLUTION BEFORE THE START OF CONSTRUCTION.

INSTALLATION AND SEPARATION REQUIREMENTS SHALL BE COORDINATED WITH THE INDIVIDUAL UTILITY PROVIDERS.

THE UTILITY PROVIDERS ARE:  
SEWER AND WATER: TOWN OF MOUNTAIN VILLAGE  
NATURAL GAS: BLACK HILLS ENERGY  
POWER: SAN MIGUEL POWER  
BROADBAND: CLEARNETWORK  
TELEPHONE: CENTURY LINK

2. PRIOR TO BEGINNING ANY CONSTRUCTION ACTIVITIES, ALL NECESSARY PERMITS SHALL BE OBTAINED BY THE OWNER OR CONTRACTOR.

3. IT IS THE CONTRACTOR'S RESPONSIBILITY TO INSURE THAT EXCAVATED SLOPES ARE SAFE AND COMPLY WITH OSHA REQUIREMENTS. REFER TO THE SITE-SPECIFIC REPORT FOR THIS PROJECT FOR ADDITIONAL INFORMATION.

4. ALL TRENCHES SHALL BE ADEQUATELY SUPPORTED OR LAID BACK PER OSHA REGULATIONS.

5. ALL MATERIALS AND CONSTRUCTION SHALL BE IN CONFORMANCE WITH THE TOWN OF MOUNTAIN VILLAGE DESIGN STANDARDS LATEST EDITION. ALL CONSTRUCTION WITHIN EXISTING STREET OR ALLEY RIGHT-OF-WAY SHALL BE SUBJECT TO TOWN OF MOUNTAIN VILLAGE INSPECTION.

6. THE CONTRACTOR SHALL HAVE ONE COPY OF THE STAMPED PLANS ON THE JOB SITE AT ALL TIMES.

7. THE CONTRACTOR SHALL NOTIFY THE TOWN 48 HOURS PRIOR TO THE START OF CONSTRUCTION.

8. THE CONTRACTOR IS RESPONSIBLE FOR IMPLEMENTING AND MAINTAINING EROSION AND SEDIMENT CONTROL MEASURES AT ALL TIMES DURING CONSTRUCTION. THE ADJOINING ROADWAYS SHALL BE FREE OF DEBRIS AT THE END OF CONSTRUCTION ACTIVITIES EACH DAY.

9. THE CONTRACTOR SHALL PROVIDE, ERECT AND MAINTAIN PROPER TRAFFIC CONTROL DEVICES UNTIL THE SITE IS OPEN TO TRAFFIC. ANY TRAFFIC CLOSURES MUST BE COORDINATED WITH THE TOWN OF MOUNTAIN VILLAGE.

10. ALL DAMAGE TO PUBLIC STREETS AND ROADS, INCLUDING HAUL ROUTES, TRAILS, OR STREET IMPROVEMENTS, OR TO PRIVATE PROPERTY, SHALL BE REPAIRED AT THE SOLE EXPENSE OF THE CONTRACTOR TO THE ORIGINAL CONDITIONS.

11. WHEN AN EXISTING ASPHALT STREET IS CUT, THE STREET MUST BE RESTORED TO A CONDITION EQUAL TO OR BETTER THAN ITS ORIGINAL CONDITION. THE FINISHED PATCH SHALL BLEND SMOOTHLY INTO THE EXISTING SURFACE. ALL LARGE PATCHES SHALL BE PAVED WITH AN ASPHALT LAY-DOWN MACHINE.

12. IF DEWATERING IS REQUIRED, THE CONTRACTOR SHALL NOTIFY THE ENGINEER. ANY DISCHARGE REQUIREMENTS SHALL BE COORDINATED WITH THE TOWN OF MOUNTAIN VILLAGE.

13. CONTRACTOR SHALL NOTIFY ALL RESIDENTS IN WRITING 24 HOURS PRIOR TO ANY SHUT-OFF IN SERVICE. THE NOTICES MUST HAVE CONTRACTOR'S PHONE NUMBER AND NAME OF CONTACT PERSON, AND EMERGENCY PHONE NUMBER FOR AFTER HOURS CALLS. ALL SHUT-OFFS MUST BE APPROVED BY THE TOWN AND TOWN VALVES AND APPURTENANCES SHALL BE OPERATED BY TOWN PERSONNEL.

14. CONTRACTOR SHALL KEEP SITE CLEAN AND LITTER FREE (INCLUDING CIGARETTE BUTTS) BY PROVIDING A CONSTRUCTION DEBRIS TRASH CONTAINER AND A BEAR-PROOF POLY-CART TRASH CONTAINER, WHICH IS TO BE LOCKED AT ALL TIMES.

15. CONTRACTOR MUST BE AWARE OF ALL TREES TO REMAIN PER THE DESIGN AND APPROVAL PROCESS AND PROTECT THEM ACCORDINGLY.

16. THE CONTRACTOR SHALL PROVIDE UNDERGROUND UTILITY AS-BUILTS TO THE TOWN.

17. ALL STRUCTURAL FILL UNDER HARDSCAPE OR ROADS MUST BE COMPACTED TO 95% MODIFIED PROCTOR (MIN.) AT PLUS OR MINUS 2% OF THE OPTIMUM MOISTURE CONTENT. NON-STRUCTURAL FILL SHALL BE PLACED AT 90% (MIN.) MODIFIED PROCTOR.

18. UNSUITABLE MATERIAL SHALL BE REMOVED AS REQUIRED BY THE SOILS ENGINEER. ALL MATERIALS SUCH AS LUMBER, LOGS, BRUSH, TOPSOIL OR ORGANIC MATERIALS OR RUBBISH SHALL BE REMOVED FROM ALL AREAS TO RECEIVE COMPACTED FILL.

19. NO MATERIAL SHALL BE COMPACTED WHEN FROZEN.

20. NATIVE TOPSOIL SHALL BE STOCKPILED TO THE EXTENT FEASIBLE ON THE SITE FOR USE ON AREAS TO BE REVEGETATED.

21. THE CONTRACTOR SHALL BE RESPONSIBLE FOR DUST ABATEMENT AND EROSION CONTROL MEASURES DEEMED NECESSARY BY THE TOWN, IF CONDITIONS WARRANT THEM.

22. ALL DISTURBED GROUND SHALL BE RE-SEEDED WITH A TOWN-APPROVED SEED MIX. REFER TO THE LANDSCAPE PLAN.

23. THE CONTRACTOR IS REQUIRED TO PROTECT ALL EXISTING SURVEY MONUMENTS AND PROPERTY CORNERS DURING GRADING AND CONSTRUCTION.

24. ALL UNDERGROUND PIPE SHALL BE PROTECTED WITH BEDDING TO PROTECT THE PIPE FROM BEING DAMAGED.

25. HOT TUBS SHALL DRAIN TO THE SANITARY SEWER (OR PUMPED TO AA CLEAN-OUT).

26. THE UTILITY PLAN DEPICTS FINAL UTILITY LOCATIONS BUT HAS BEEN COMPLETED AT A PRELIMINARY STAGE. CONTRACTOR SHALL VERIFY ALIGNMENTS WITH THE ARCHITECT PRIOR TO CONSTRUCTION.

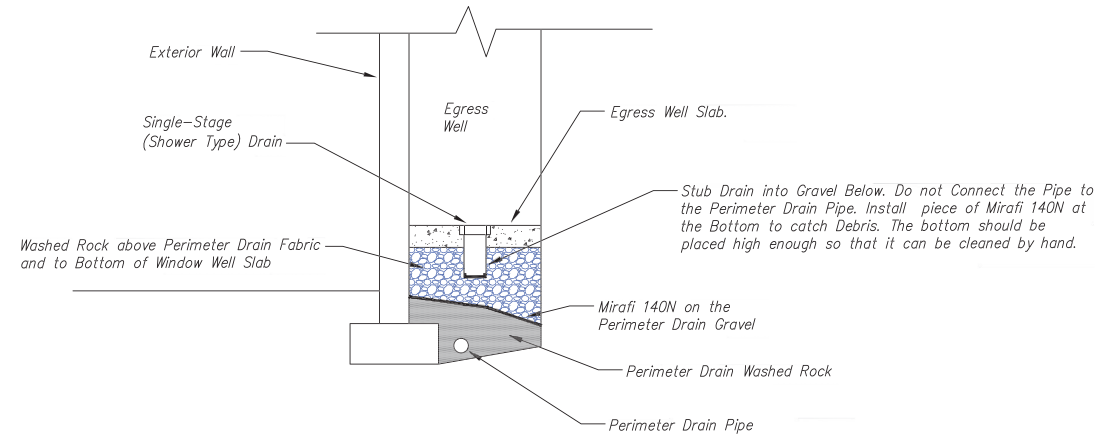

TYPICAL EGRESS WELL, LIGHT WELL, OR SUNKEN BASEMENT ENTRANCE  
SECTION VIEW  
NOT TO SCALE



Uncompahgre  
Engineering, LLC

P.O. Box 3945  
Telluride, CO 81435  
970-729-0683

SUBMISSIONS:

SUBMITTAL	2022-03-14
SUBMITTAL	2024-05-16
Added Storm Mit.	2024-10-21

Oldmixon Residence  
Lot 10  
The Boulders  
Mtn. Village, CO



CONTRACTOR TO REVIEW AND COMPARE ALL CHAPTERS AND INTERDISCIPLINARY DRAWINGS AND REPORT ANY DISCREPANCIES TO THE ARCHITECT PRIOR TO ANY FIELD WORK BEING DONE IN ACCORDANCE WITH AIA DOCUMENT A201

Notes

C1

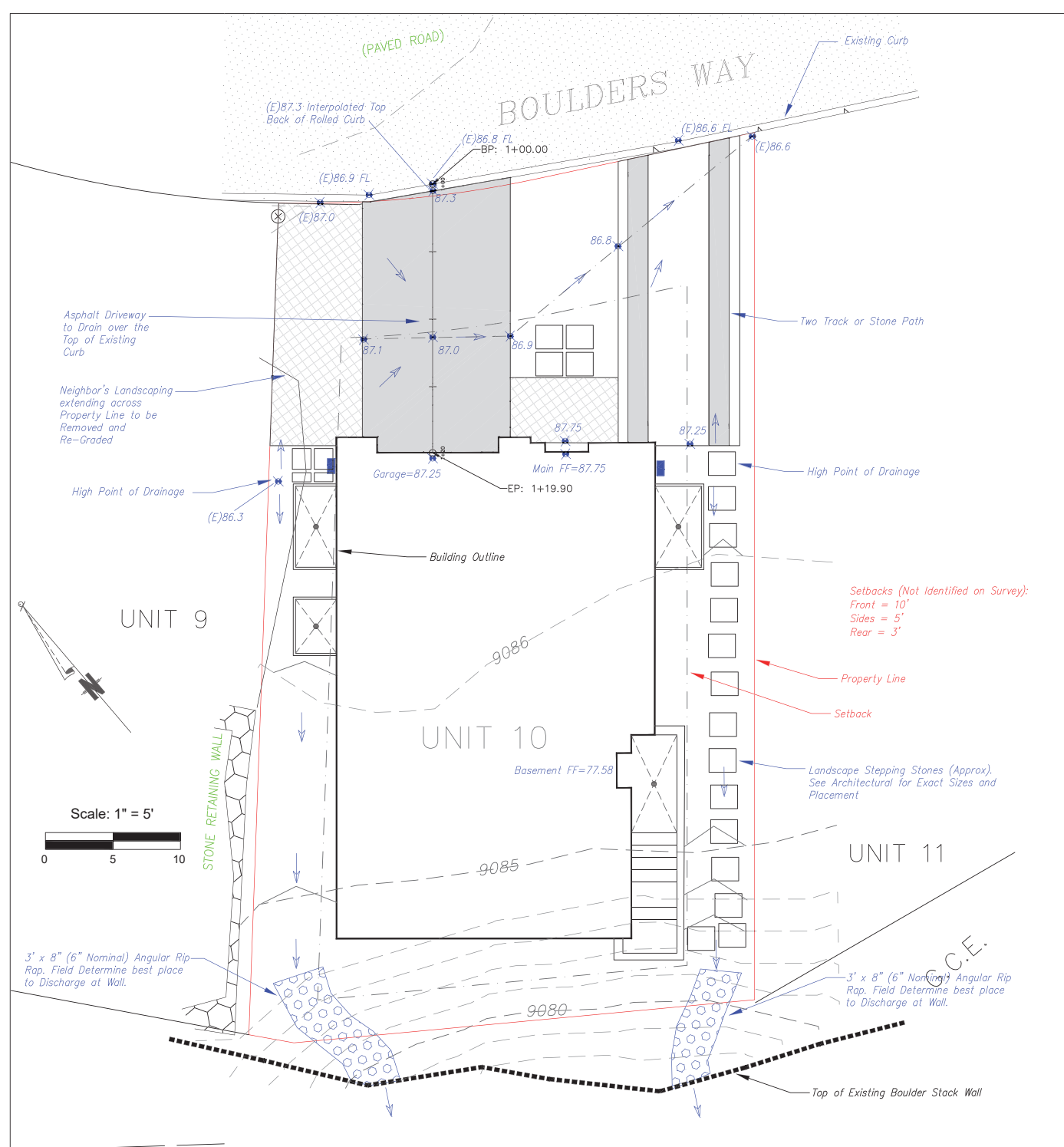

Site Grading and Drainage Plan

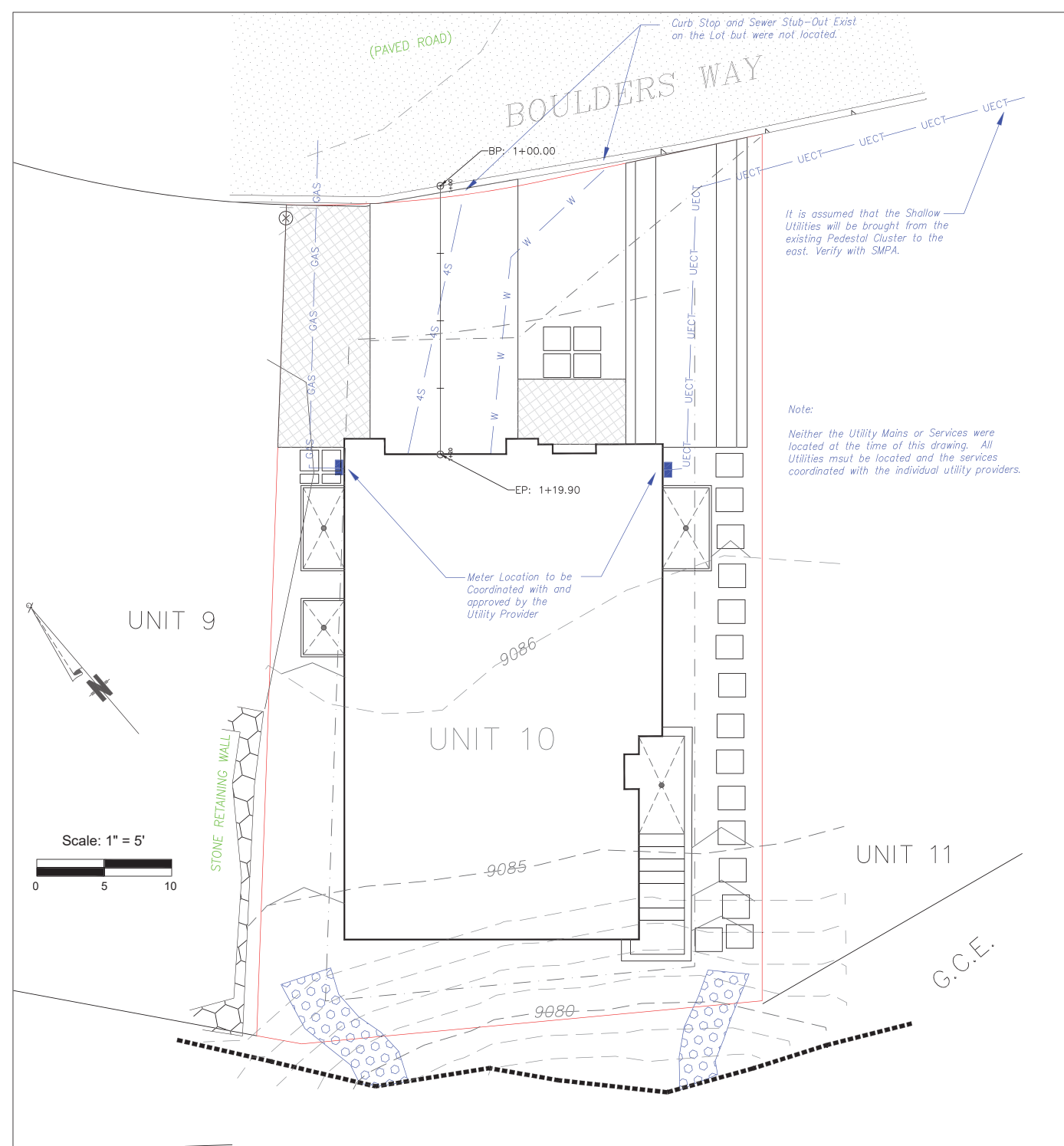

Utility Plan

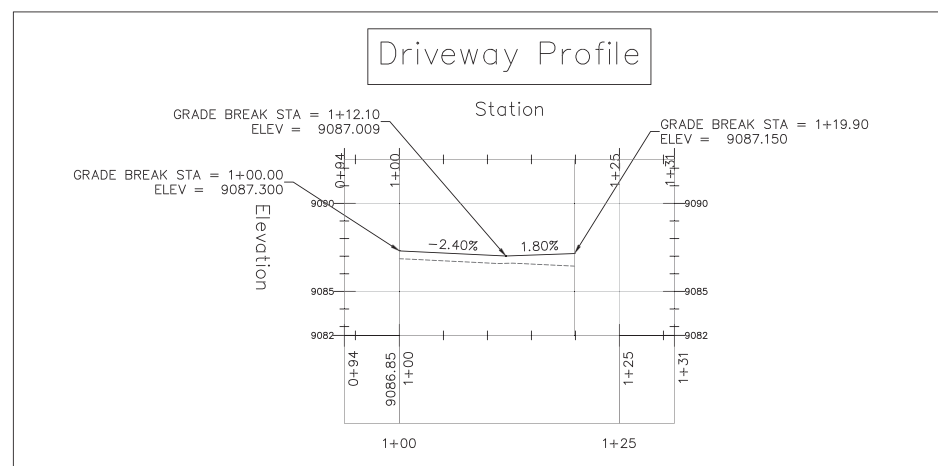

Driveway Profile



Uncompahgre Engineering, LLC

P.O. Box 3945  
Telluride, CO 81435  
970-729-0683

SUBMISSIONS:

SUBMITTAL	2022-03-14
SUBMITTAL	2024-05-16
Added Storm Mitig.	2024-10-21

Oldmixon Residence  
Lot 10  
The Boulders  
Mtn. Village, CO









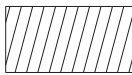

CONTRACTOR TO REVIEW AND COMPARE ALL CHAPTERS AND INTERDISCIPLINARY DRAWINGS AND REPORT ANY DISCREPANCIES TO THE ARCHITECT PRIOR TO ANY FIELD WORK BEING DONE IN ACCORDANCE WITH AIA DOCUMENT A201

Site Grading and Drainage Plan  
and  
Utility Plan

C2

### CONSTRUCTION MITIGATION LEGEND

	LIMITS OF CONSTRUCTION		EXISTING ASPEN TREE TO REMAIN
	TEMPORARY PARKING		EXISTING EVERGREEN TREE TO REMAIN
	REVEGETATION AREAS		
	LIMIT OF CONSTRUCTION		
	PERIMETER FENCING		
	TREE PROTECTION FENCING		

- ALL DEVELOPMENT SHALL COMPLY WITH DECLARATION OF CONDOMINIUM FOR KNOLL ESTATES, A CONDOMINIUM IN ADDITION TO TOWN OF MOUNTAIN VILLAGE CDC 17.7.20 REQUIREMENTS.
- COORDINATE LOCATION OF PORTA TOILET, TRASH, RECYCLE, MATERIAL STORAGE AND PARKING WITH THE TOWN OF MOUNTAIN VILLAGE.
- ALL EXISTING TREES TO BE PROTECTED THROUGHOUT CONSTRUCTION.

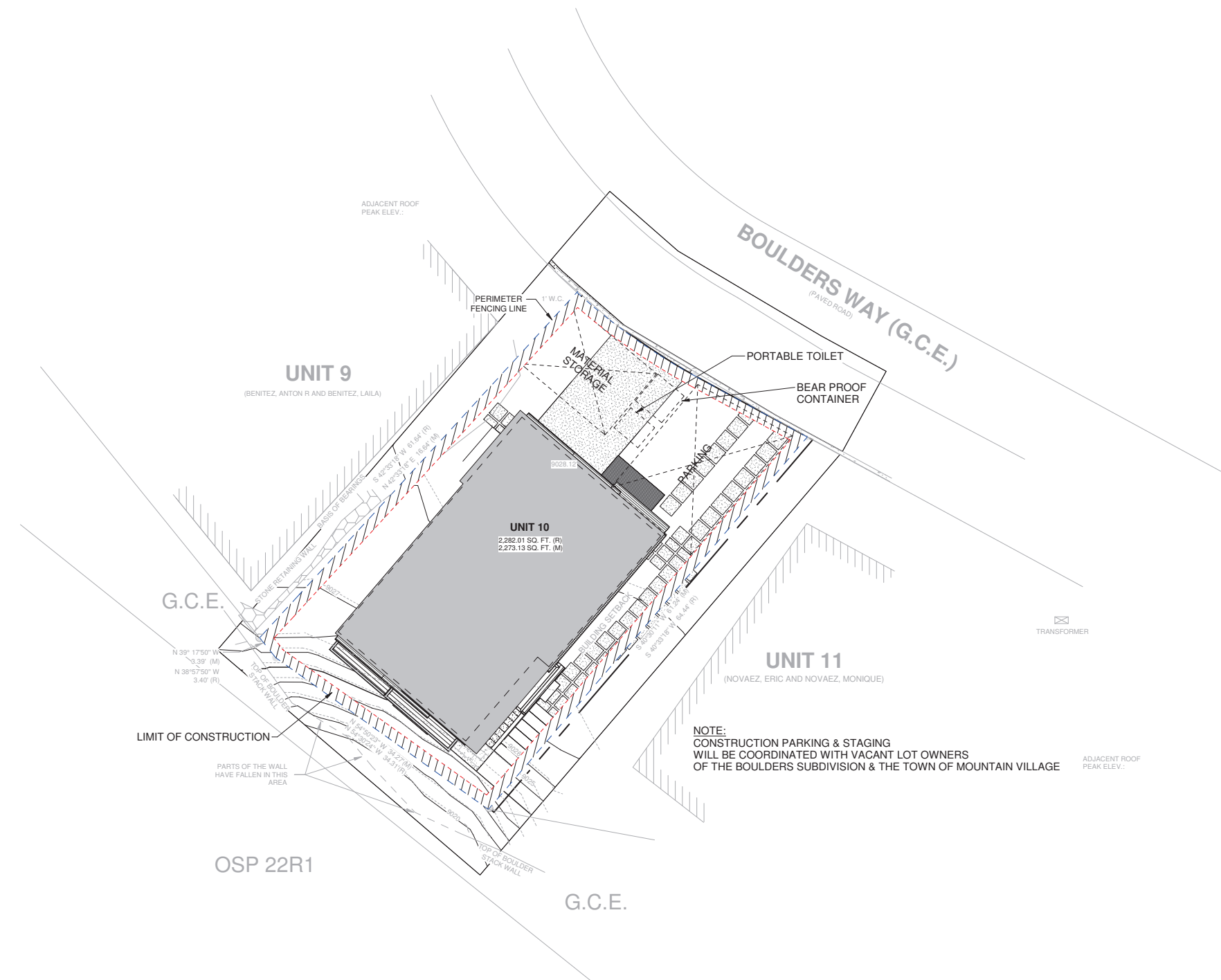

**1 CONSTRUCTION MITIGATION PLAN**  
 1/8" = 1'-0"

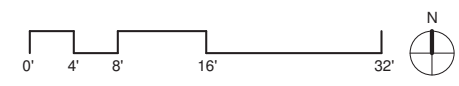

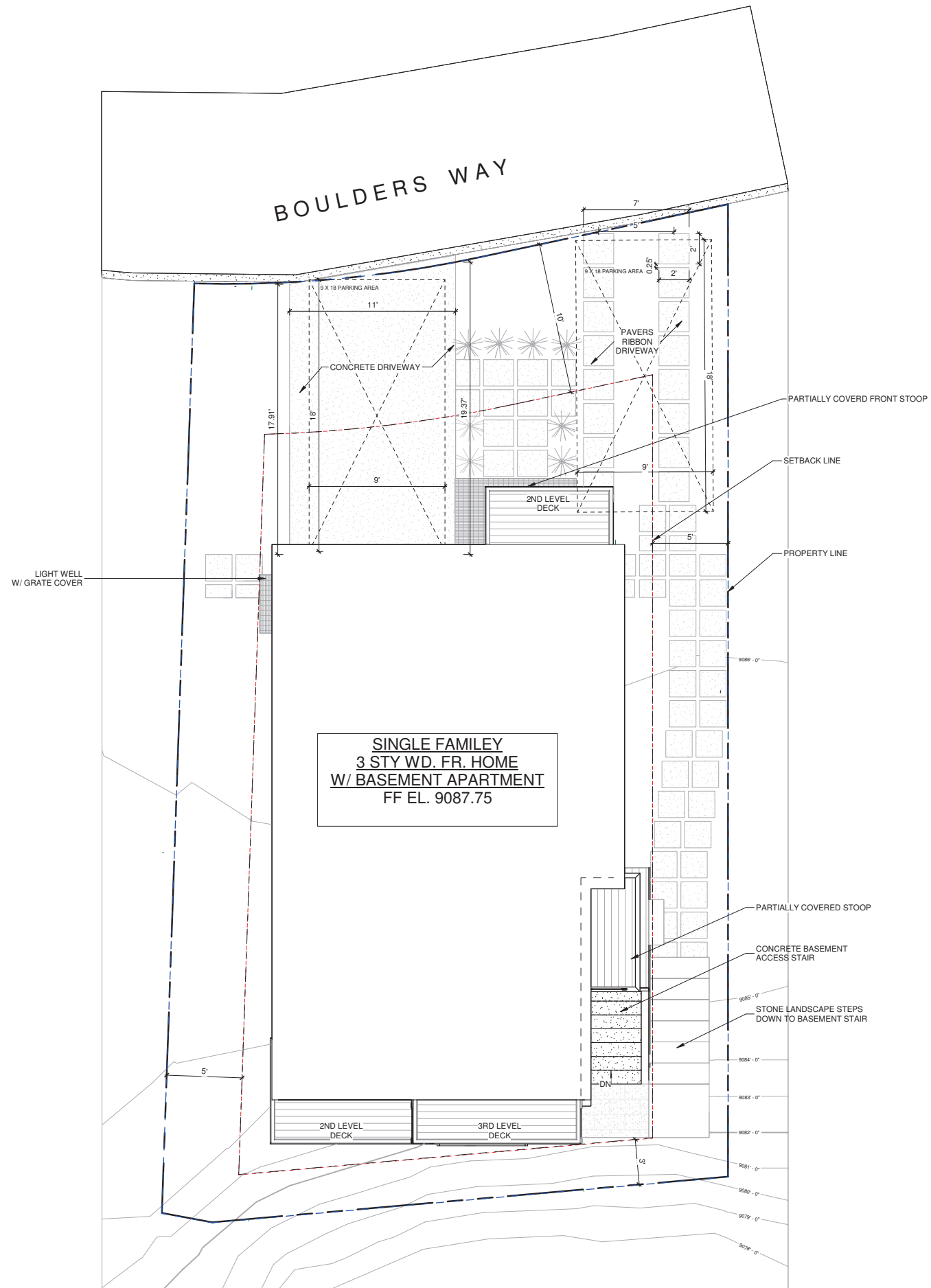

**1 ARCHITECTURAL SITE PLAN**  
 1/4" = 1'-0"

**SERENITY MV**

Unit-10, Boulders Way, Mountain Village  
 Telluride, CO 81435, USA

ARCHITECTURAL  
 SITE PLAN

SHEET NUMBER

10/14/2024 2:04:50 PM

**A1.1**

PLANTING SCHEDULE				
Type	LATIN NAME	Type Mark	SIZE	Count
WOODS ROSE	ROSA WOODSII	P1		8
Grand total: 8				

**GENERAL NOTES:**

- ALL TREES AND SHRUBS TO BE LOCATED BY PROJECT ARCHITECT / OWNER.
- ALL TREES AND SHRUBS SHALL BE BACKED FILLED WITH A TOPSOIL / ORGANIC FERTILIZER MIXTURE AT A 2:1 RATIO.
- NECESSARY TREES SHALL BE STACKED WITH 4" METAL POSTS. TREES SHALL BE GUYED WITH 12 GAUGE GALVANIZED WIRE AND POLYPROPYLENE TREE RACE STRIPS.
- PERENNIAL PLANTING BEDS SHALL BE TILLED 6" DEPTH AND AMENDED WITH TOPSOIL AND ORGANIC FERTILIZER AT A 2:1 RATIO.
- SEE PLANTING DETAILS FOR ALL DECIDUOUS AND EVERGREEN TREES.
- MULCH ALL PERENNIAL BEDS WITH A PINE BARK SOIL CONDITIONER BY SOUTHWEST IMPORTERS; SHREDDED CEDAR BARK.
- ALL PLANT MATERIAL TO MEET THE AMERICAN STANDARD FOR NURSERY STOCK.
- LANDSCAPING SHALL BE IN ACCORDANCE WITH L.U.C. "SECTION 3-505 MAINTENANCE, REMOVAL, OR RELOCATION OF TREES".

**NOXIOUS WEEDS:**

- ALL PLANTED MATERIALS INCLUDING SEEDS, SHALL BE NON NOXIOUS SPECIES AS SPECIFIED WITHIN THE SAN MIGUEL COUNTY'S MOST CURRENT NOXIOUS WEED LIST.

**LANDSCAPE MAINTENANCE NOTES:**

- TURF SHALL BE AERATED 2 TO 3 TIMES PER YEAR TO INCREASE THE WATER ABSORPTION RATE. NECESSARY ORGANIC FERTILIZATION AND AMENDMENT SHALL BE INCORPORATED AT THE SAME TIME.
- NECESSARY ORGANIC FERTILIZERS AND AMENDMENT SHALL BE ADDED TO PERENNIAL BEDS SEASONALLY ALONG WITH MULCH.
- ALL SHRUBS IN SNOW SHED AREAS TO BE CUT BACK IN FALL TO 12"-18" IN HEIGHT.
- IRRIGATION SYSTEM TO BE BLOWN OUT BY OCTOBER 31ST EACH FALL AND TURNED ON BY JUNE 1ST EACH SPRING.

**REVEGETATION NOTES:**

- SUBSOIL SURFACE SHALL BE TILLED TO A 4" DEPTH ON NON FILL AREAS.
- TOPSOIL SHALL BE SPREAD AT A MINIMUM DEPTH OF 4" OVER ALL AREAS TO BE REEMITTED (EXCEPT OF SLOPES GREATER THAN 3:1) AND AMENDMENT ROTOTILLED AT A RATE OF THREE CUBIC YARDS PER THOUSAND SQUARE FEET.
- BROADCASTING OF SEED SHALL BE DONE IMMEDIATELY AFTER TOPSOIL IS APPLIED (WITHIN 10 DAYS) TO MINIMIZE EROSION AND WEEDS.
- AREAS WHICH HAVE BEEN COMPACTED OR RELATIVELY UNDISTURBED NEEDING SEEDING, SHALL BE SCARIFIED BEFORE BROADCASTING THE SEED.
- BROADCASTING WITH SPECIFIED SEED MIX AND FOLLOW WITH DRY MULCHING, STRAW OR HAY SHALL BE UNIFORMLY APPLIED OVER SEEDED AREA AT A RATE OF 1.5 TONS PER ACRE FOR HAY OR 2 TONS PER ACRE FOR STRAW, CRIMP IN.
- ON SLOPES GREATER THAN 3:1 EROSION CONTROL BLANKET SHALL BE APPLIED IN PLACE OF STRAW MULCH AND PINNED.
- ALL UTILITY CUTS SHALL BE REVEGETATED WITHIN TWO WEEKS AFTER INSTALLATION OF UTILITIES TO PREVENT WEED INFESTATION.
- SEED ALL AREAS LABELED NATIVE GRASS SEED WITH THE FOLLOWING MIXTURE AT A RATE OF 12 LBS. PER ACRE.

SPECIES	PURE LIVE SEED PER ACRE
WESTERN YARROW	5%
TALL FESCUE	10%
ARIZONA FESCUE	5%
HARD FESCUE	5%
CREEPING RED FESCUE	10%
ALPINE BLUEGRASS	15%
CANADA BLUEGRASS	10%
PERENNIAL RYEGRASS	15%
SLENDER WHEATGRASS	10%
MOUNTAIN BROME	15%
MOUNTAIN BROME (BROMAR)	10%

**LANDSCAPE LEGEND**

	CONCRETE PAVERS		INDIGENOUS SHRUBS
	FENCE; WOOD FRAME AND HOGWIRE		TREE; ASPEN
	METAL GATE TO MATCH FENCE		TREE; SPRUCE
	METAL LANDSCAPE WALL		FENCE; WOOD
	METAL GRATE WITH 3' X 3' EGRESS HATCH AT WINDOW WELL		
	DISTURBED AREAS		
	MULCH LANDSCAPE BEDDING		
	PERENNIAL BEDDING		
	FLAGSTONE		

**NOTE:**  
ALL EXISTING TREES TO BE PROTECTED THROUGHOUT CONSTRUCTION.

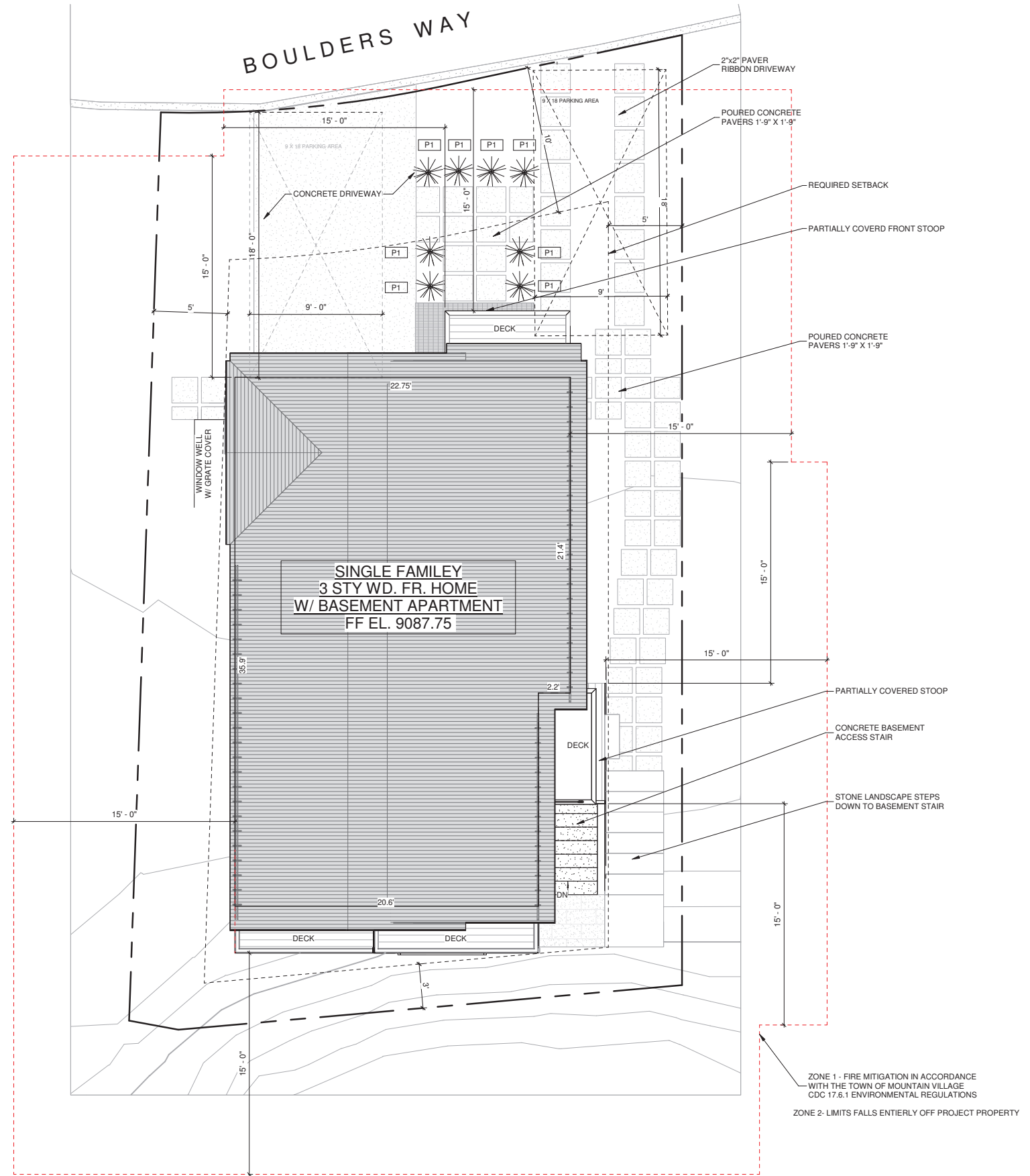

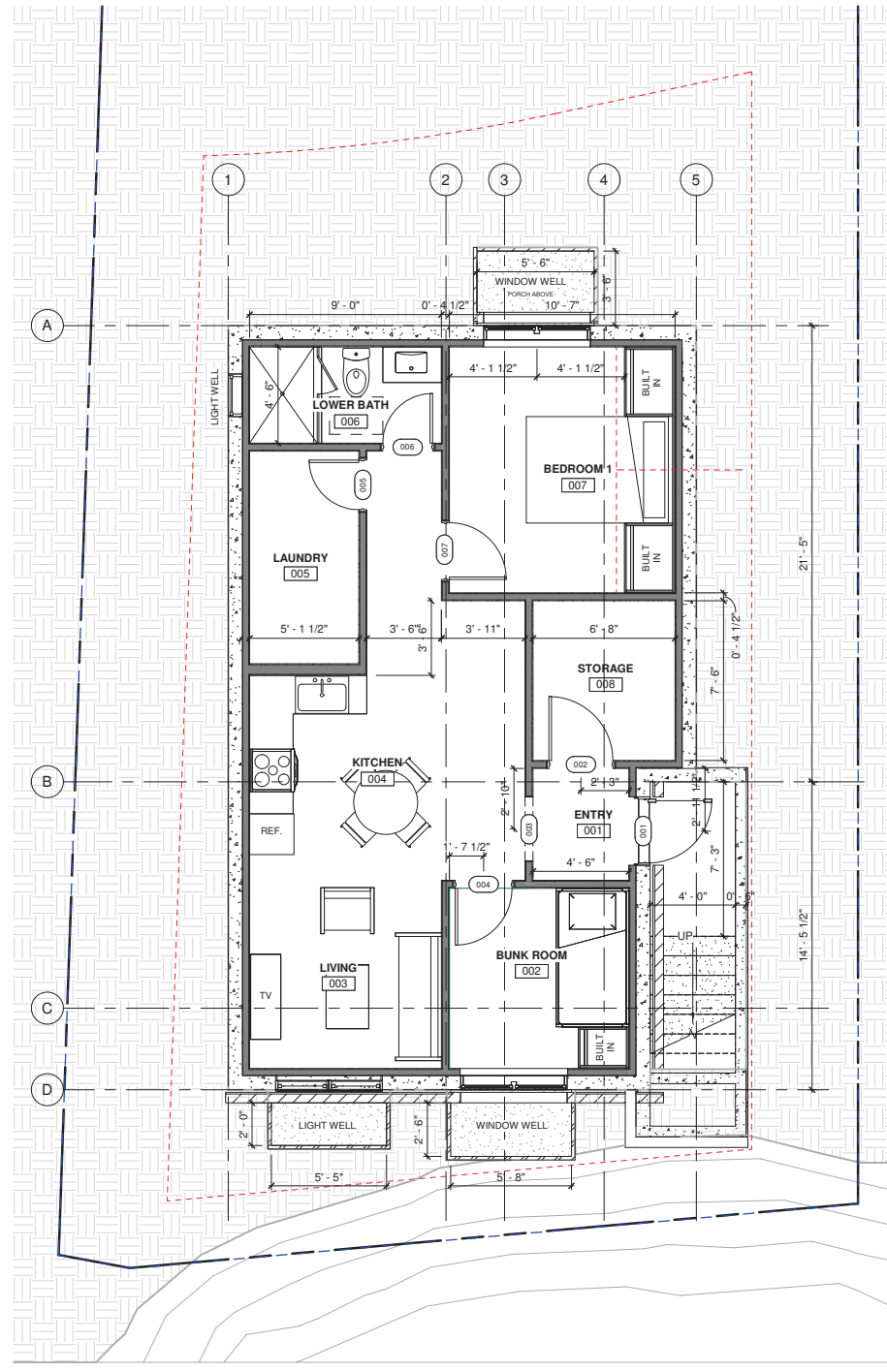

**3 BASEMENT**  
 1/4" = 1'-0"

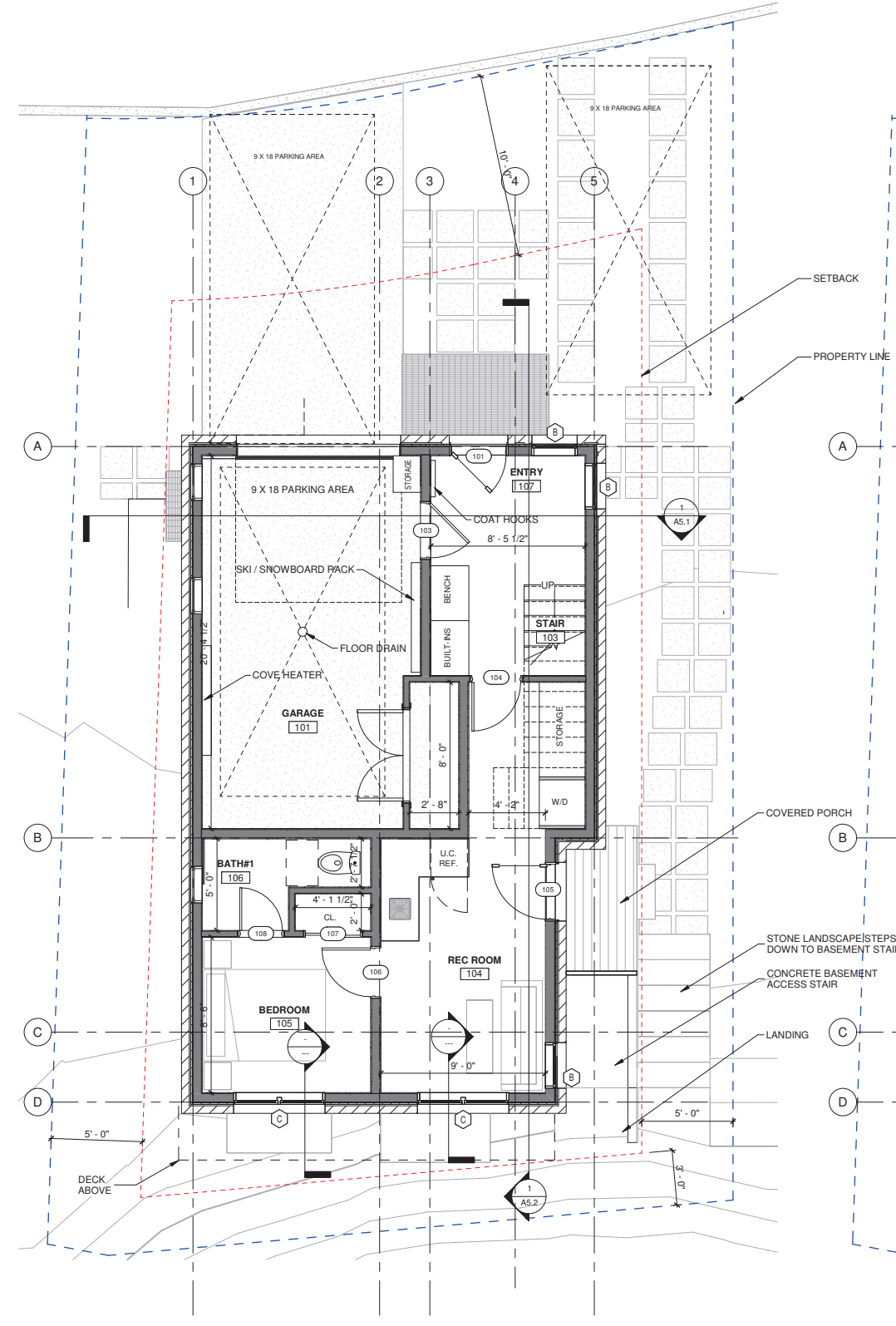

**1 GROUND LEVEL PLAN**  
 1/4" = 1'-0"

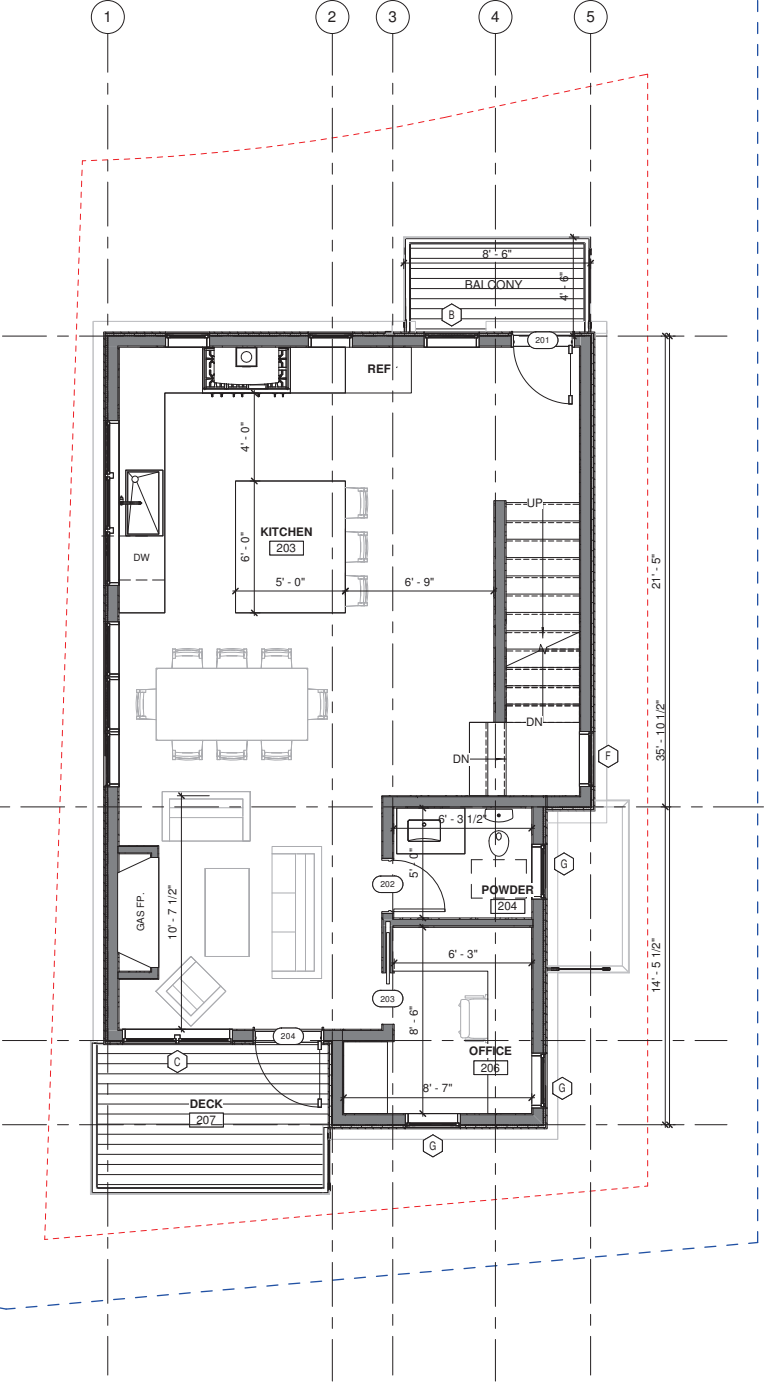

**2 MAIN LEVEL FLOOR PLAN**  
 1/4" = 1'-0"

**SERENITY MV**

Unit-10, Boulders Way, Mountain Village  
 Telluride, CO 81435, USA

FLOOR PLANS

SHEET NUMBER

**A3.1**

10/14/2024 2:04:52 PM

©shift architects

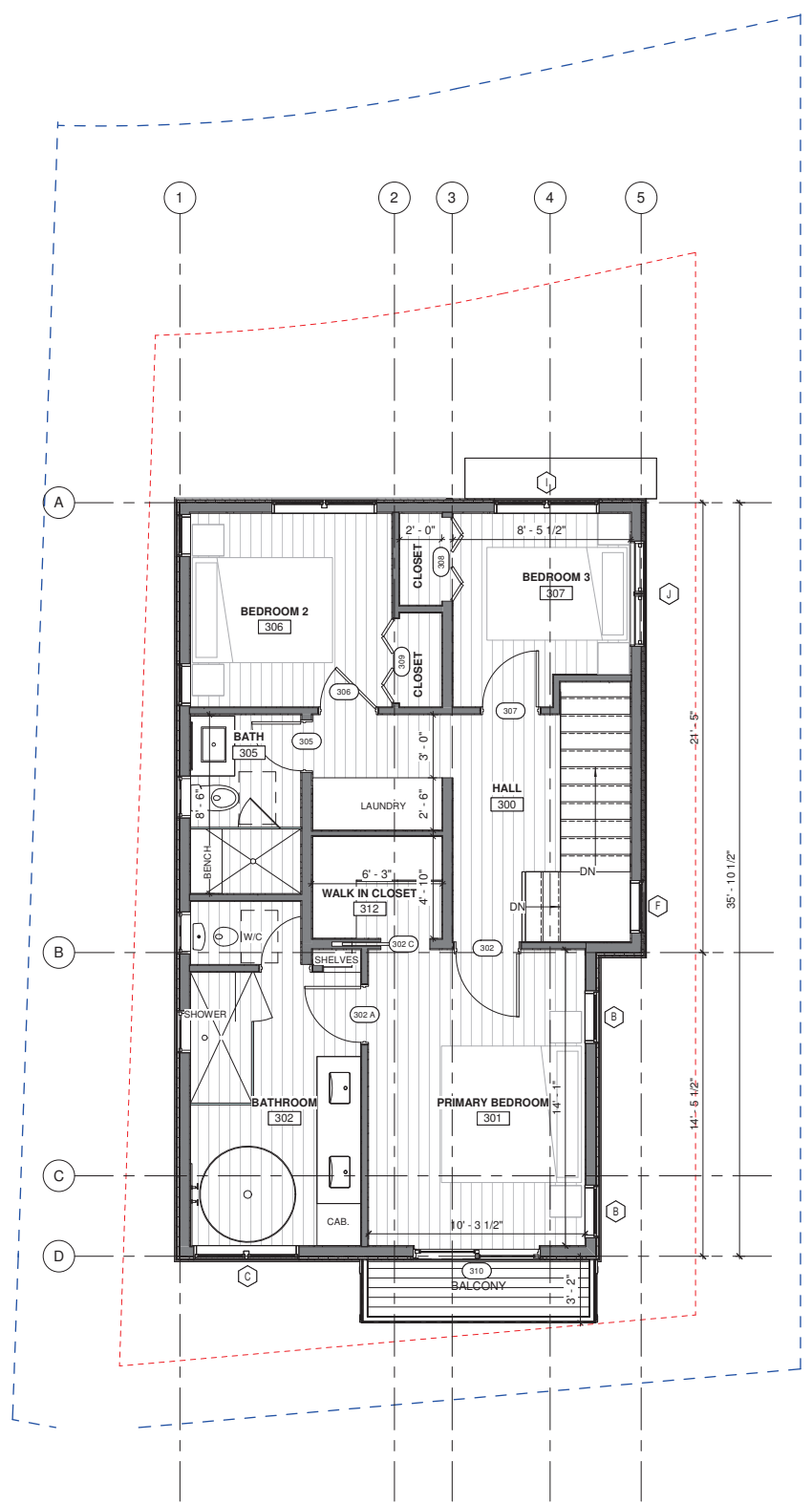

**1 UPPER LEVEL FLOOR PLAN**  
 1/4" = 1'-0"

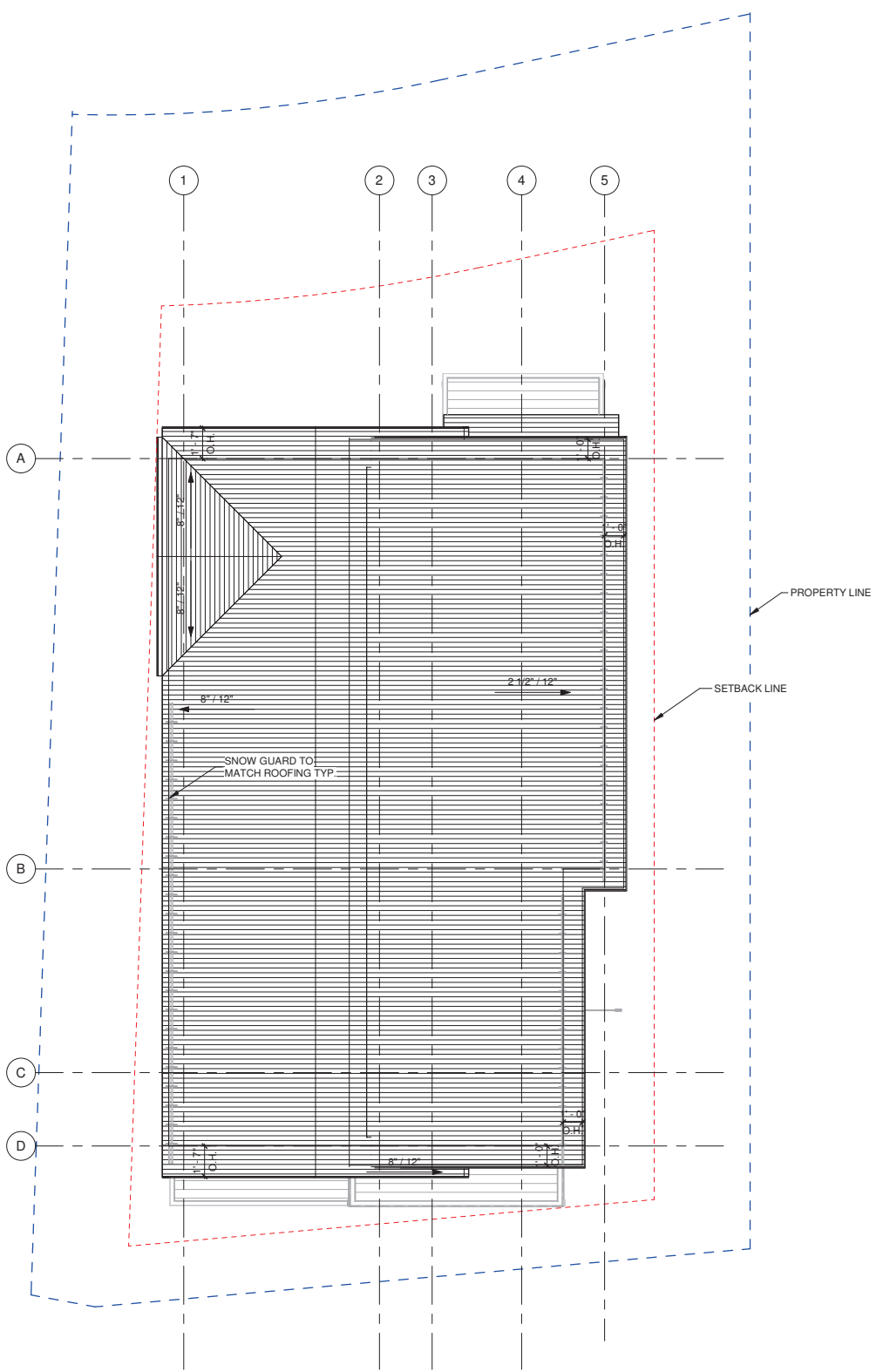

**2 ROOF PLAN**  
 1/4" = 1'-0"



**SERENITY MV**

Unit-10, Boulders Way, Mountain Village  
 Telluride, CO 81435, USA

FLOOR & ROOF  
 PLAN

SHEET NUMBER

**A3.2**

10/14/2024 2:04:53 PM



**MATERIAL CALCULATIONS**

NORTH	
STONE	157 SF
WOOD SIDING	352 SF
WINDOW / DOOR GLAZING	147 SF
GARAGE DOOR	72 SF
TOTAL	728 SF
SOUTH	
STONE	278 SF
WOOD SIDING	322 SF
WINDOW/DOOR GLAZING	203 SF
TOTAL	803 SF
EAST	
STONE	464 SF
WOOD SIDING	599 SF
WINDOW/DOOR GLAZING	140 SF
TOTAL	1,203 SF
WEST	
CONCRETE	9 SF
STONE	436 SF
WOOD SIDING	563 SF
WINDOW/DOOR GLAZING	108 SF
TOTALS	1,116 SF
TOTALS	
TOTAL SF	3,850 SF 100 %
CONCRETE	9 SF 0 %
STONE	1,335 SF 35 %
WOOD SIDING	1,836 SF 48 %
WINDOW/DOOR GLAZING	598 SF 15 %
GARAGE DOORS	72 SF 2 %

GLAZING CALCULATIONS ARE BASE ON UNIT SIZE. ACTUAL GLASS T.B.D. BY MANUFACTURER'S SPECIFICATIONS.  
 STONE VENEER CALCULATION REQUIREMENT PER TOWN OF MOUNTAIN VILLAGE CDC 17.5.6 EXTERIOR WALL MATERIALS E.1



**1 EAST ELEVATION**  
 1/4" = 1'-0"

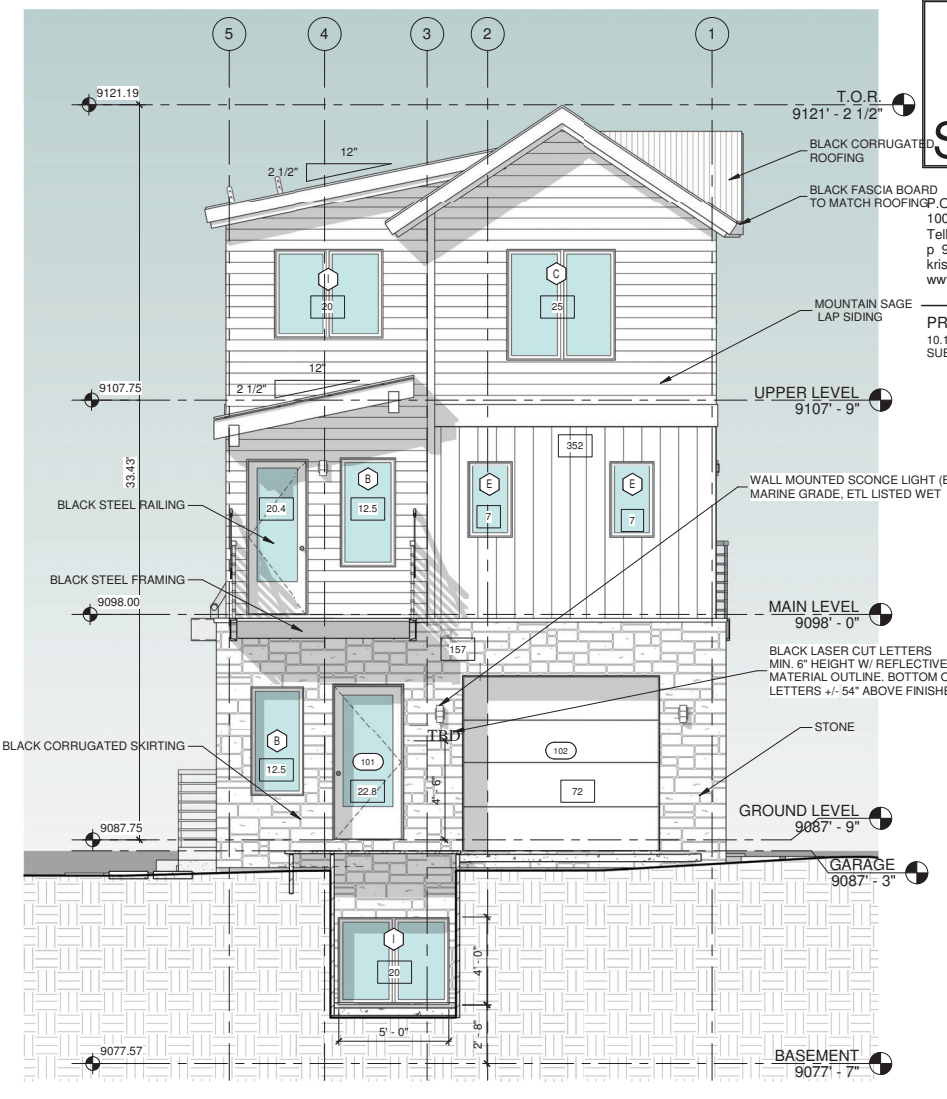

**2 NORTH ELEVATION**  
 1/4" = 1'-0"

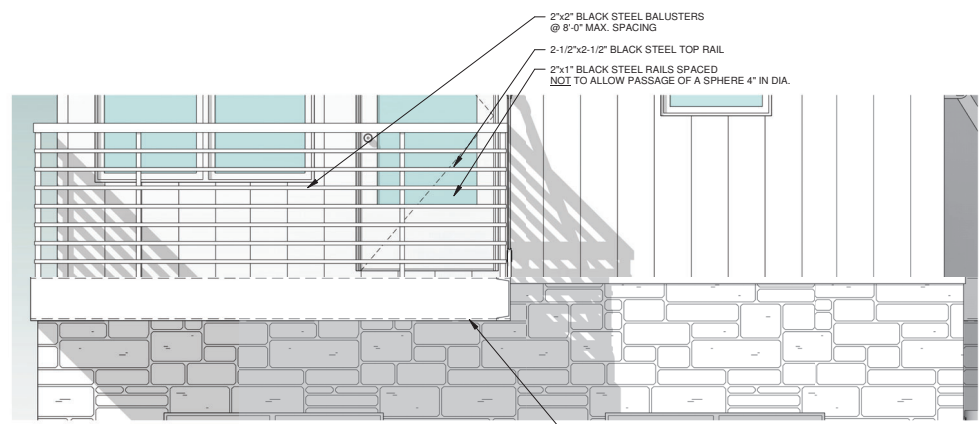

**RAILING DETAIL**  
 1/2" = 1'-0"

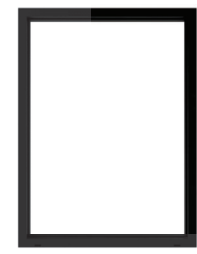

**BLACK FRAME WINDOWS**



**BLACK CORRUGATED SIDING & ROOFING**



**FLINT SAWN STONE**

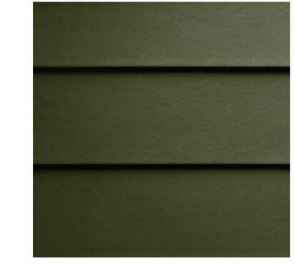

**MOUNTAIN SAGE LAP SIDING**



**2X6 CEDAR DECKING & SOFFIT**



**12X24 LIME BLACK PAVERS**

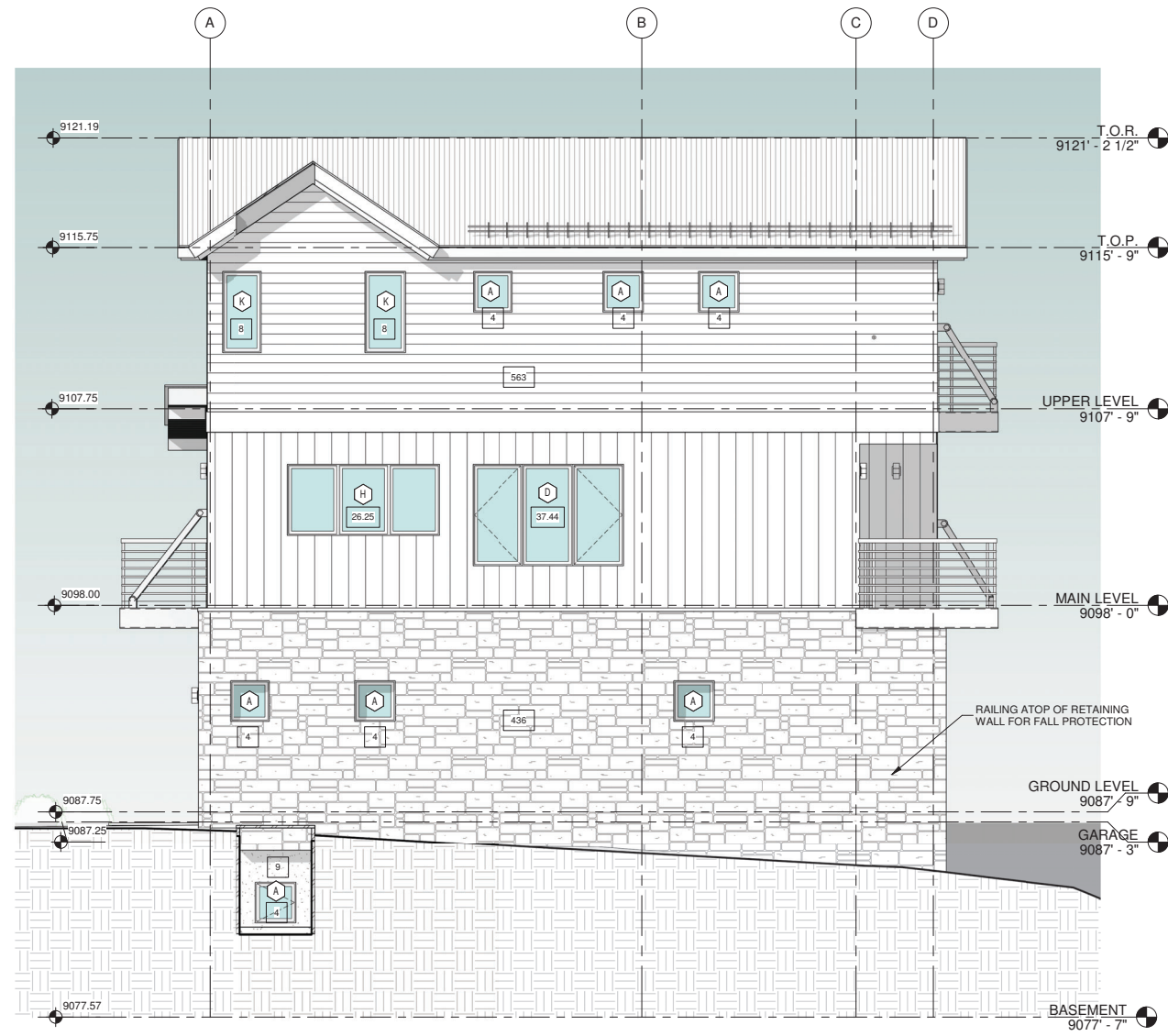

**1 WEST ELEVATION**  
 1/4" = 1'-0"

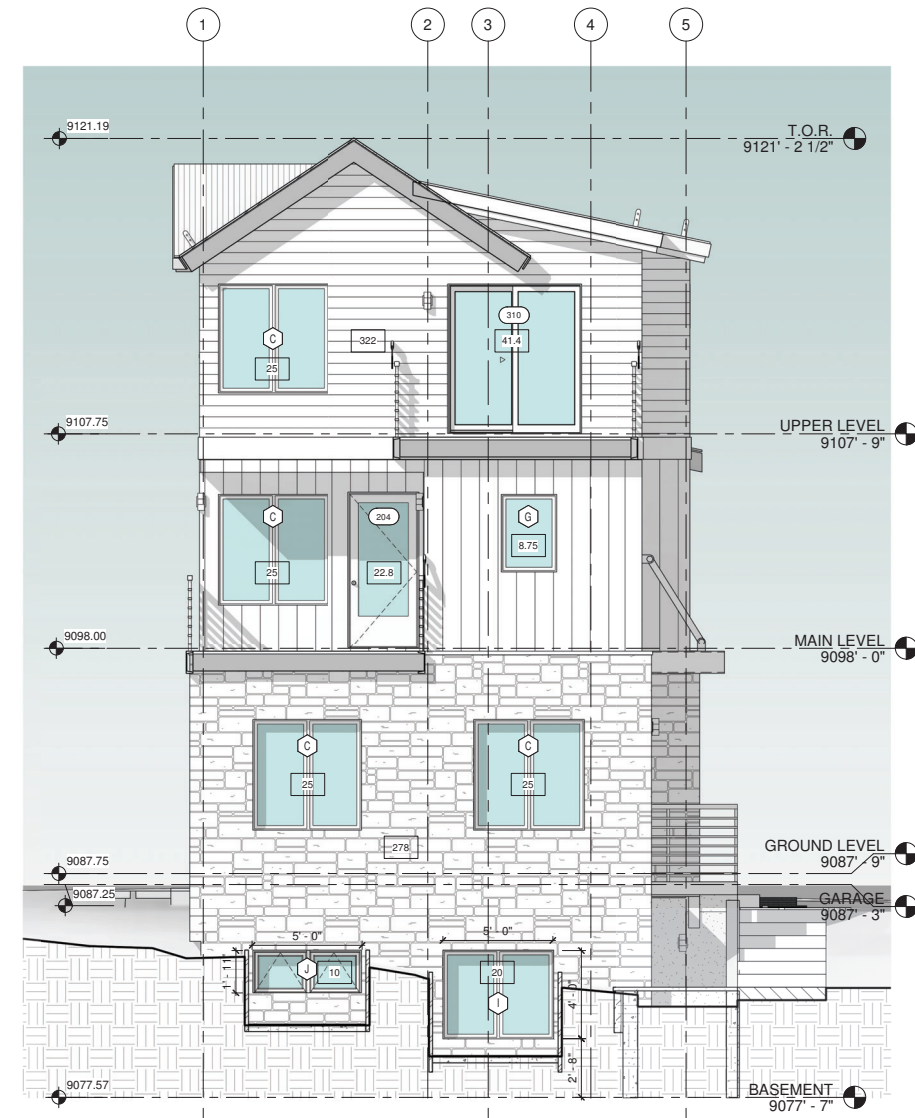

**2 SOUTH ELEVATION**  
 1/4" = 1'-0"

**SERENITY MV**

Unit-10, Boulders Way, Mountain Village  
 Telluride, CO 81435, USA

PROPOSED  
 ELEVATIONS

SHEET NUMBER

**A4.2**

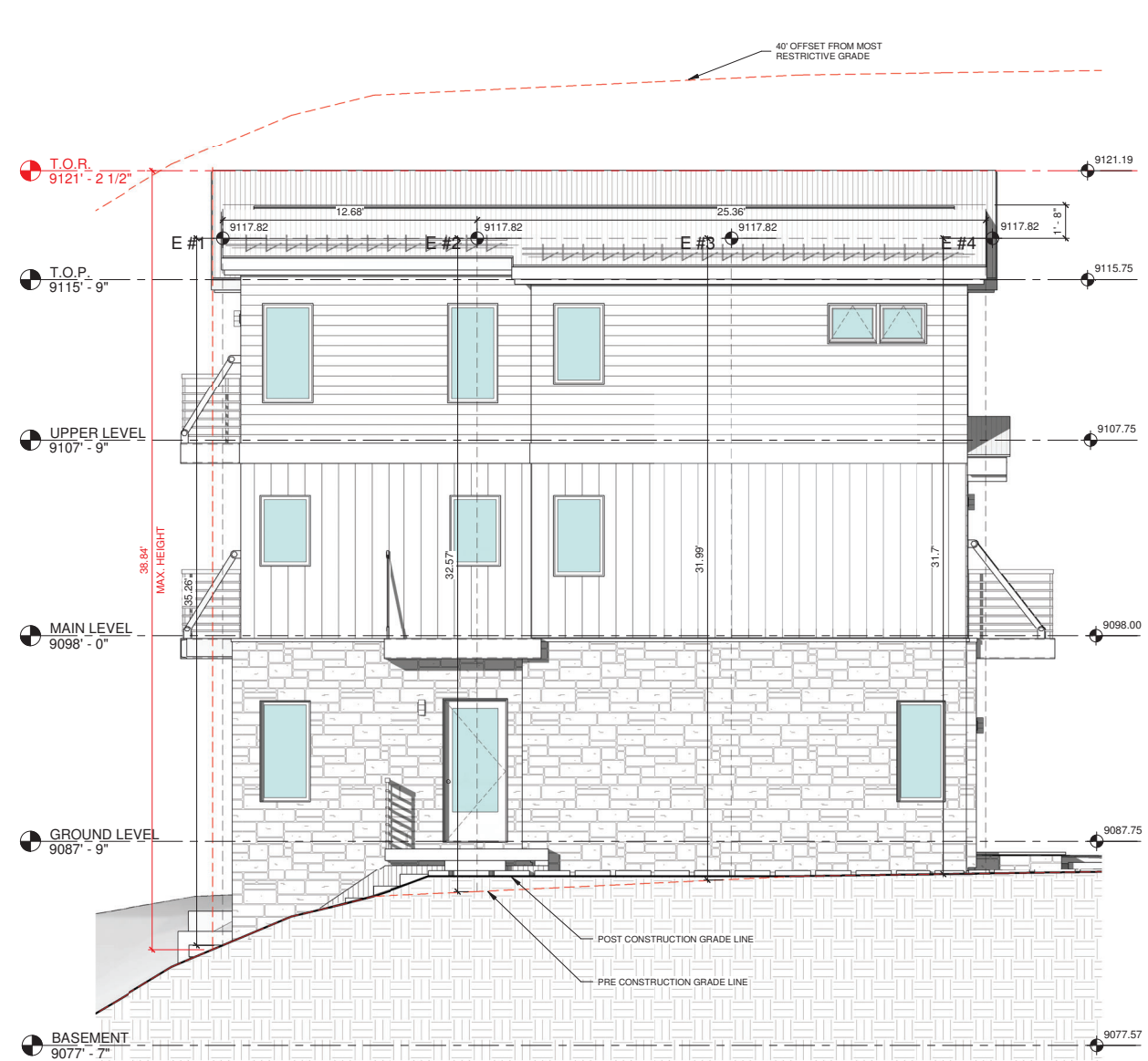

AVG ROOF HT :	
NORTH ELEVATION	
N1	31.20'
N2	31.77'
N3	31.74'
N4	31.15'
NORTH AVERAGE	31.46'
SOUTH ELEVATION	
S1	33.42'
S2	34.96'
S3	36.48'
S4	36.29'
SOUTH AVERAGE	35.28'
EAST ELEVATION	
E1	35.09'
E2	32.40'
E3	31.82'
E4	31.53'
EAST AVERAGE	32.71'
WEST ELEVATION	
W1	31.81'
W2	31.24'
W3	31.47'
W4	32.19'
W5	32.78'
W6	33.48'
WEST AVERAGE	32.16'
TOTAL AVERAGE	32.90'

**1 EAST ELEVATION**  
1/4" = 1'-0"

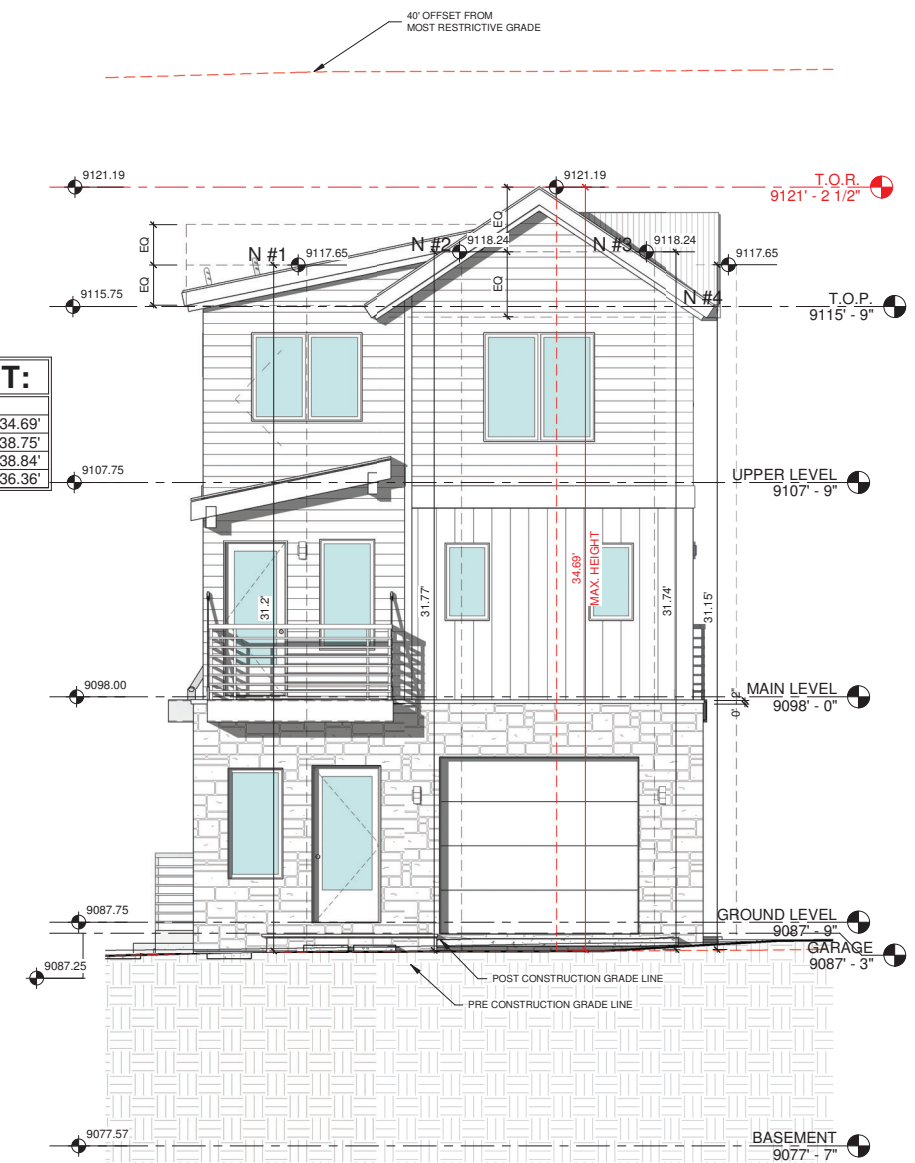

MAX. ROOF HT:	
NORTH ELEVATION	34.69'
SOUTH ELEVATION	38.75'
EAST ELEVATION	38.84'
WEST ELEVATION	36.36'

**2 NORTH ELEVATION**  
1/4" = 1'-0"

**SERENITY MV**

Unit-10, Boulders Way, Mountain Village  
Telluride, CO 81435, USA

ELEVATION  
HEIGHT CALCS

SHEET NUMBER

**A4.3**

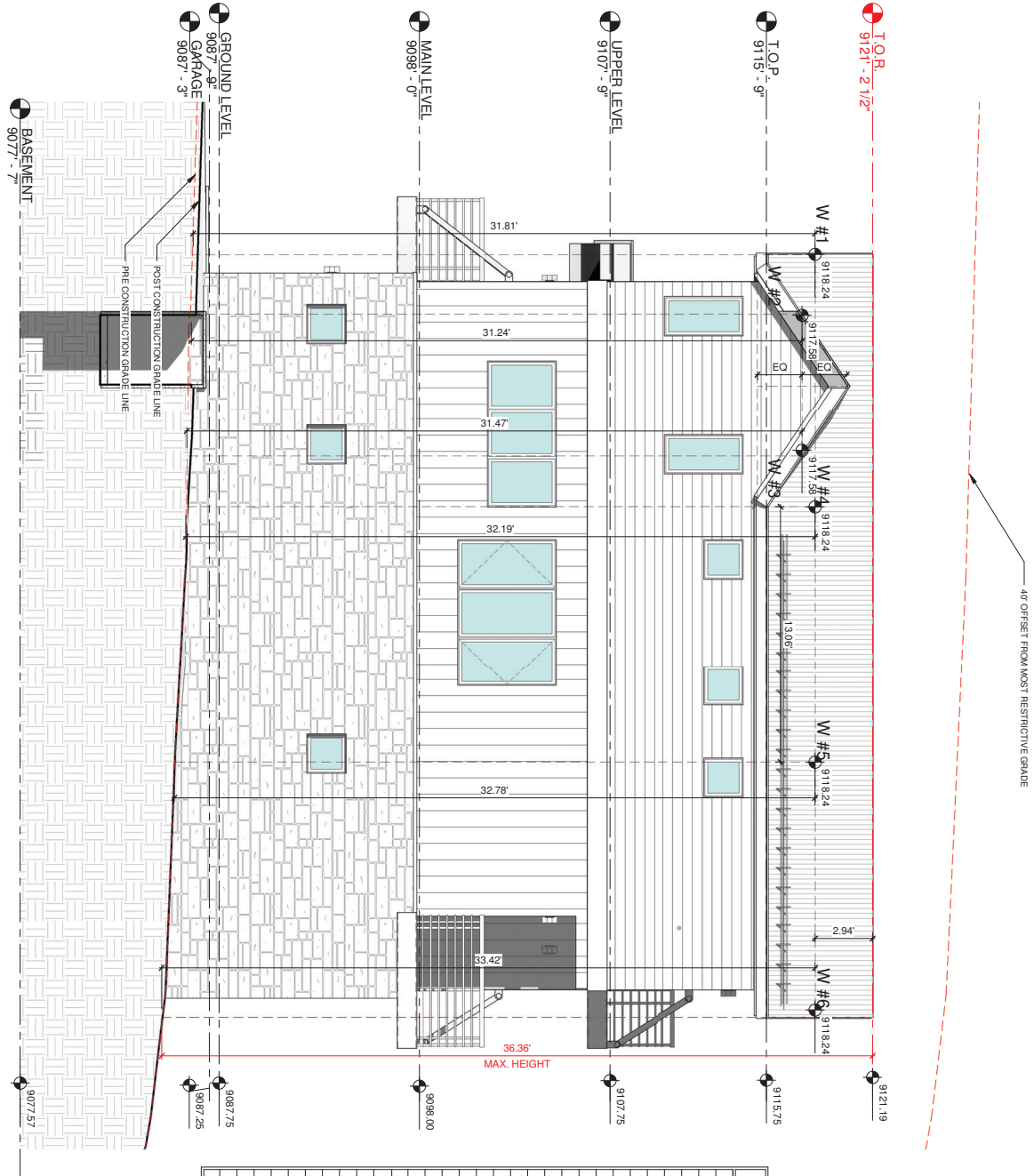

AVG ROOF HT :	
NORTH ELEVATION	
N1	31.20'
N2	31.77'
N3	31.74'
N4	31.15'
NORTH AVERAGE	
	31.46'
SOUTH ELEVATION	
S1	33.42'
S2	34.96'
S3	36.48'
S4	36.29'
SOUTH AVERAGE	
	35.28'
EAST ELEVATION	
E1	35.09'
E2	32.40'
E3	31.82'
E4	31.53'
EAST AVERAGE	
	32.71'
WEST ELEVATION	
W1	31.81'
W2	31.24'
W3	31.47'
W4	32.19'
W5	32.78'
W6	33.48'
WEST AVERAGE	
	32.16'
TOTAL AVERAGE	
	32.90'

MAX. ROOF HT :	
NORTH EL ELEVATION	34.69'
SOUTH EL ELEVATION	38.75'
EAST ELEVATION	38.84'
WEST ELEVATION	36.36'

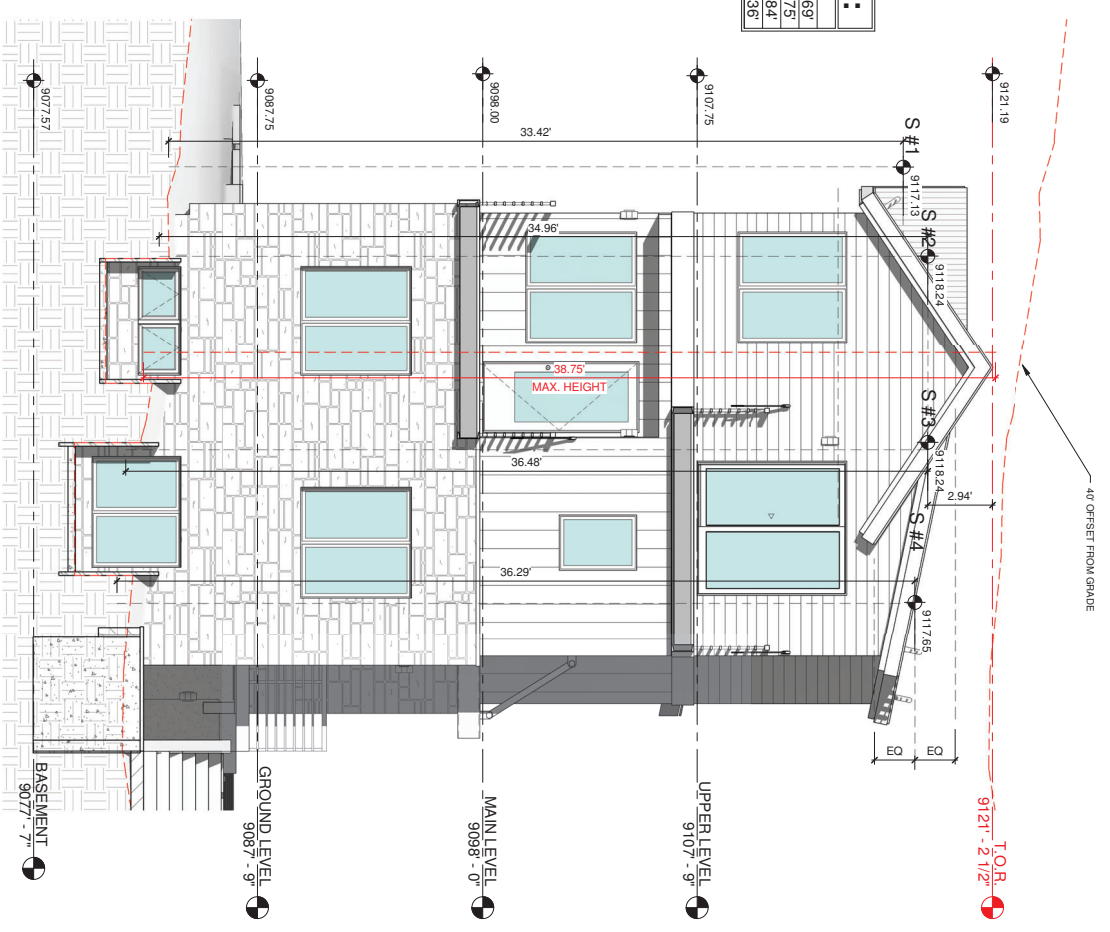

**1 WEST ELEVATION**  
1/4" = 1'-0"

**2 SOUTH ELEVATION**  
1/4" = 1'-0"

**SERENITY MV**

Unit-10, Boulders Way, Mountain Village  
Telluride, CO 81435, USA

ELEVATION  
HEIGHT CALCS

SHEET NUMBER

**A4.4**



**NW PERSPECTIVE**

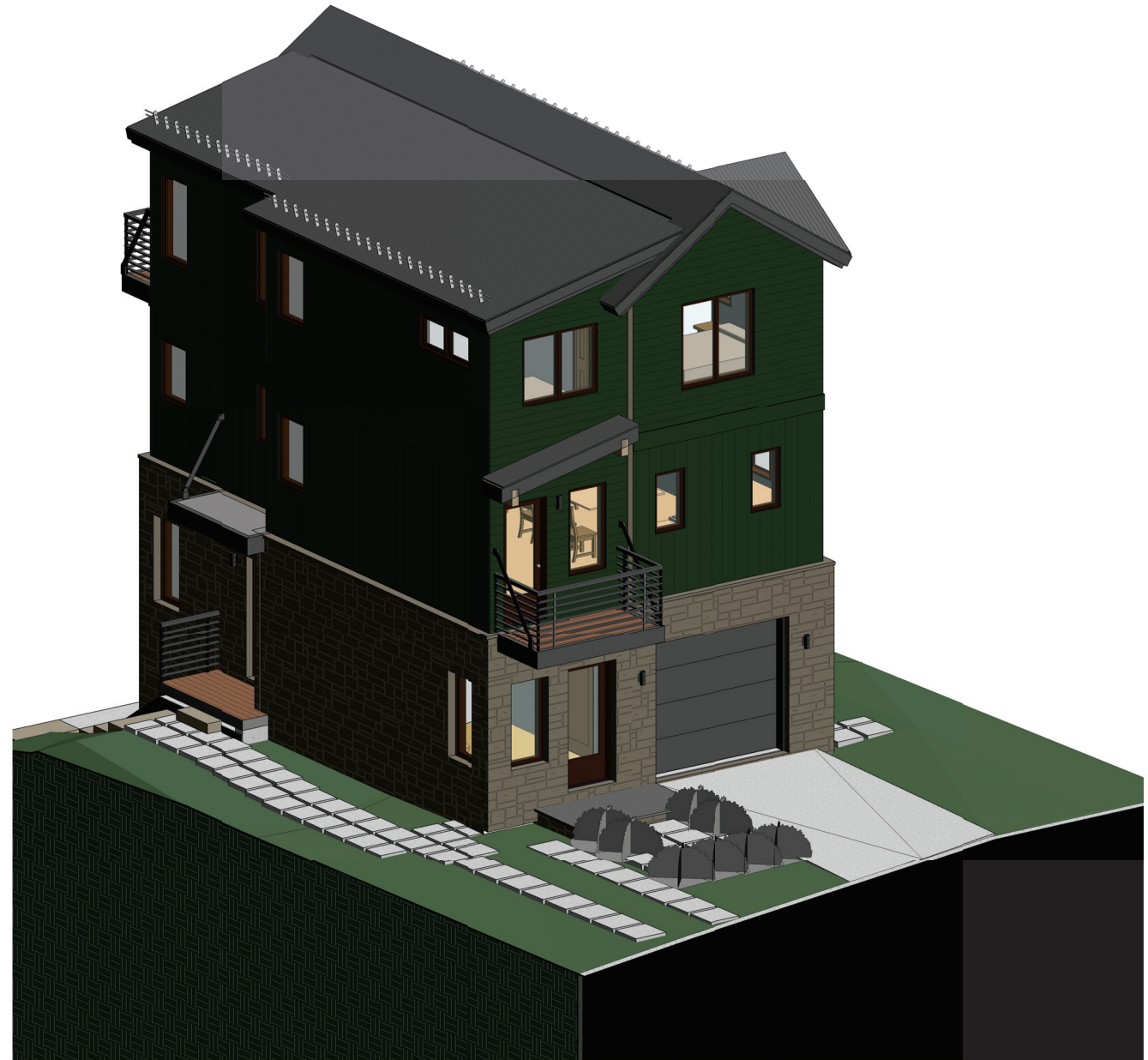

**NE PERSPECTIVE**

**SERENITY MV**

Unit-10, Boulders Way, Mountain Village  
 Telluride, CO 81435, USA

COLORIZED  
 PERSPECTIVE

©shift architects

SHEET NUMBER

10/14/2024 2:05:15 PM

**A4.5**

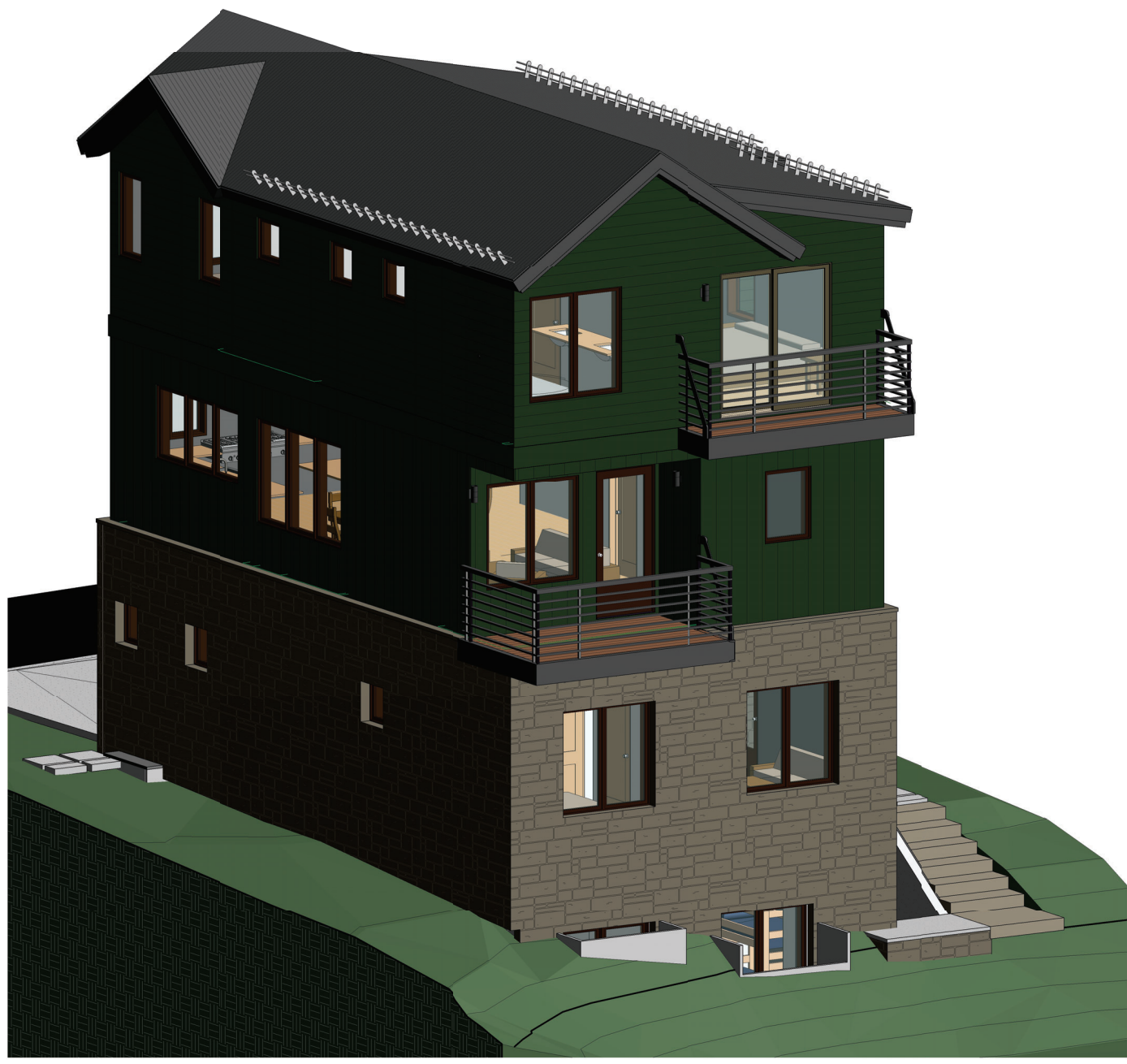

SW PERSPECTIVE



SE PERSPECTIVE

**SERENITY MV**

Unit-10, Boulders Way, Mountain Village  
Telluride, CO 81435, USA

COLORIZED  
PERSPECTIVE

SHEET NUMBER

**A4.6**

10/14/2024 2:05:18 PM

©shift architects

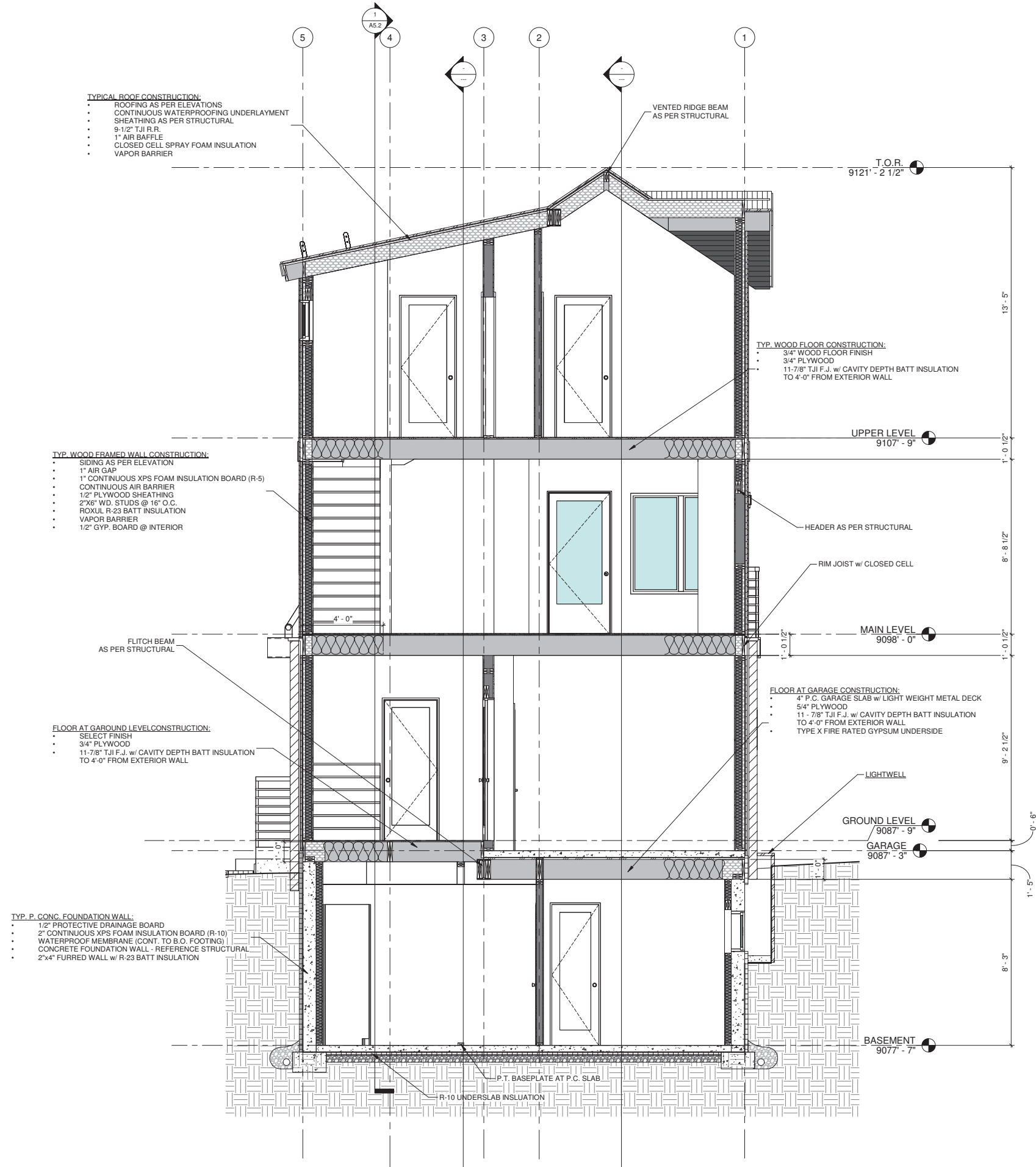

**TYPICAL ROOF CONSTRUCTION:**

- ROOFING AS PER ELEVATIONS
- CONTINUOUS WATERPROOFING UNDERLAYMENT
- SHEATHING AS PER STRUCTURAL
- 9-1/2" TJI F.R.
- 1" AIR Baffle
- CLOSED CELL SPRAY FOAM INSULATION
- VAPOR BARRIER

**TYP. WOOD FRAMED WALL CONSTRUCTION:**

- SIDING AS PER ELEVATION
- 1" AIR GAP
- 1" CONTINUOUS XPS FOAM INSULATION BOARD (R-5)
- CONTINUOUS AIR BARRIER
- 1/2" PLYWOOD SHEATHING
- 2"x6" WD. STUDS @ 16" O.C.
- ROXUL R-23 BATT INSULATION
- VAPOR BARRIER
- 1/2" GYP. BOARD @ INTERIOR

**FLOOR AT GAROUND LEVEL CONSTRUCTION:**

- SELECT FINISH
- 3/4" PLYWOOD
- 11-7/8" TJI F.J. w/ CAVITY DEPTH BATT INSULATION TO 4'-0" FROM EXTERIOR WALL

**TYP. P. CONC. FOUNDATION WALL:**

- 1/2" PROTECTIVE DRAINAGE BOARD
- 2" CONTINUOUS XPS FOAM INSULATION BOARD (R-10)
- WATERPROOF MEMBRANE (CONT. TO B.O. FOOTING)
- CONCRETE FOUNDATION WALL - REFERENCE STRUCTURAL
- 2"x4" FURRED WALL w/ R-23 BATT INSULATION

**TYP. WOOD FLOOR CONSTRUCTION:**

- 3/4" WOOD FLOOR FINISH
- 3/4" PLYWOOD
- 11-7/8" TJI F.J. w/ CAVITY DEPTH BATT INSULATION TO 4'-0" FROM EXTERIOR WALL

**FLOOR AT GARAGE CONSTRUCTION:**

- 4" P.C. GARAGE SLAB w/ LIGHT WEIGHT METAL DECK
- 5/4" PLYWOOD
- 11-7/8" TJI F.J. w/ CAVITY DEPTH BATT INSULATION TO 4'-0" FROM EXTERIOR WALL
- TYPE X FIRE RATED GYPSUM UNDERSIDE

**SECTION AT GARAGE**  
3/8" = 1'-0"

**SERENITY MV**

Unit-10, Boulders Way, Mountain Village  
Telluride, CO 81435, USA

BUILDING SECTION

SHEET NUMBER



**SECTION AT STAIRS**

3/8" = 1'-0"

**SERENITY MV**

Unit-10, Boulders Way, Mountain Village  
Telluride, CO 81435, USA

BUILDING  
SECTION

SHEET NUMBER

**A5.2**

10/14/2024 2:05:19 PM



DOOR SCHEDULE					
DOOR TYPE	MARK	HEIGHT	WIDTH	HARDWARE	Description
EXTERIOR SINGLE GLASS PANEL	001	7' - 0"	3' - 0"		
INTERIOR SINGLE SWING	002	7' - 0"	3' - 0"		
INTERIOR SINGLE SWING	003	0' - 0"	0' - 0"		
INTERIOR SINGLE SWING	004	7' - 0"	2' - 8"		
	005	7' - 0"	2' - 4"		
INTERIOR DOUBLE SLIDING	006	7' - 0"	2' - 4"		
INTERIOR SINGLE SWING	007	7' - 0"	2' - 8"		
EXTERIOR SINGLE GLASS PANEL	101	7' - 0"	3' - 0"		
OVERHEAD GARAGE DOOR	102	8' - 0"	9' - 0"		
INTERIOR SINGLE SWING	103	7' - 0"	3' - 0"		
INTERIOR SINGLE PANEL	104	7' - 0"	2' - 8"		
EXTERIOR SINGLE GLASS PANEL	105	7' - 0"	3' - 0"		
INTERIOR SINGLE SWING	106	7' - 0"	2' - 8"		
INTERIOR DOUBLE SLIDING	107	7' - 0"	3' - 0"		
INTERIOR SINGLE SWING	108	7' - 0"	2' - 4"		
INTERIOR DOUBLE SWING	109	7' - 0"	2' - 6"		
EXTERIOR SINGLE GLASS PANEL	201	7' - 0"	2' - 8"		
INTERIOR SINGLE SWING	202	7' - 0"	2' - 4"		
INTERIOR SINGLE POCKET	203	7' - 0"	2' - 4"		
EXTERIOR SINGLE GLASS PANEL	204	7' - 0"	3' - 0"		
INTERIOR SINGLE SWING	302	7' - 0"	3' - 0"		
INTERIOR SINGLE SWING	302 A	7' - 0"	2' - 8"		
INTERIOR SINGLE POCKET	302 C	7' - 0"	2' - 4"		
INTERIOR SINGLE SWING	305	7' - 0"	2' - 4"		
INTERIOR SINGLE SWING	306	7' - 0"	2' - 8"		
INTERIOR SINGLE SWING	307	7' - 0"	2' - 8"		
INTERIOR BIFOLDING	308	7' - 0"	4' - 0"		
INTERIOR BIFOLDING	309	7' - 0"	4' - 0"		
EXTERIOR SLIDING GLASS	310	6' - 10"	6' - 0"	1/2"	
INTERIOR SINGLE SWING	311	7' - 0"	2' - 4"		
INTERIOR SINGLE SWING	312	7' - 0"	2' - 4"		

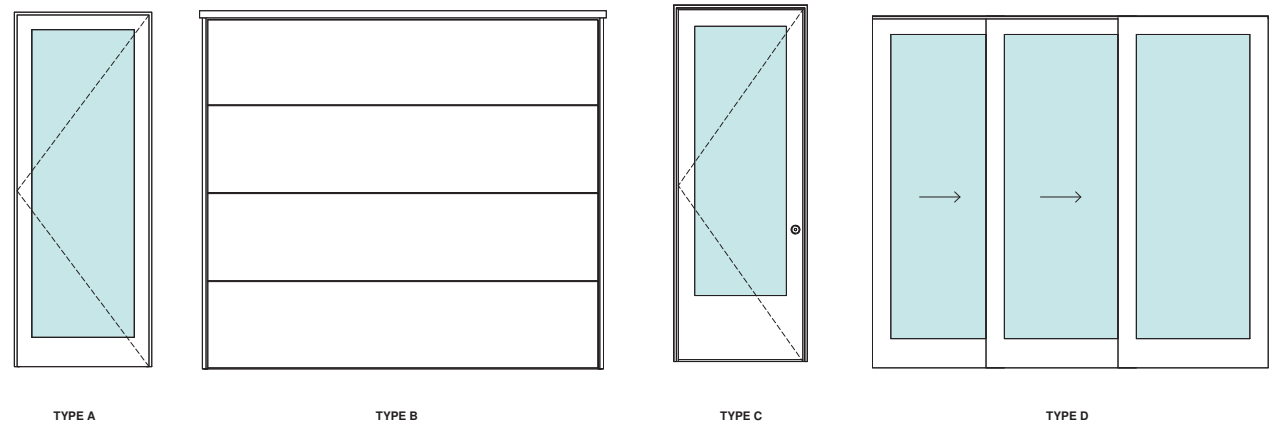
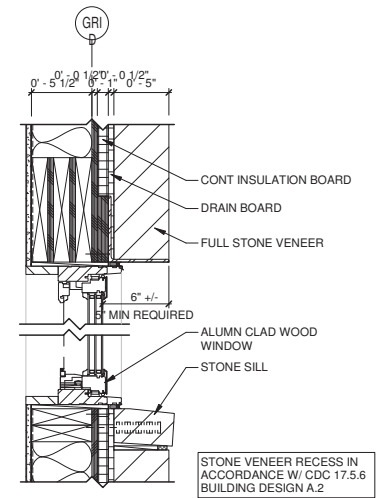

**EXTERIOR DOOR TYPES**  
1/2" = 1'-0"

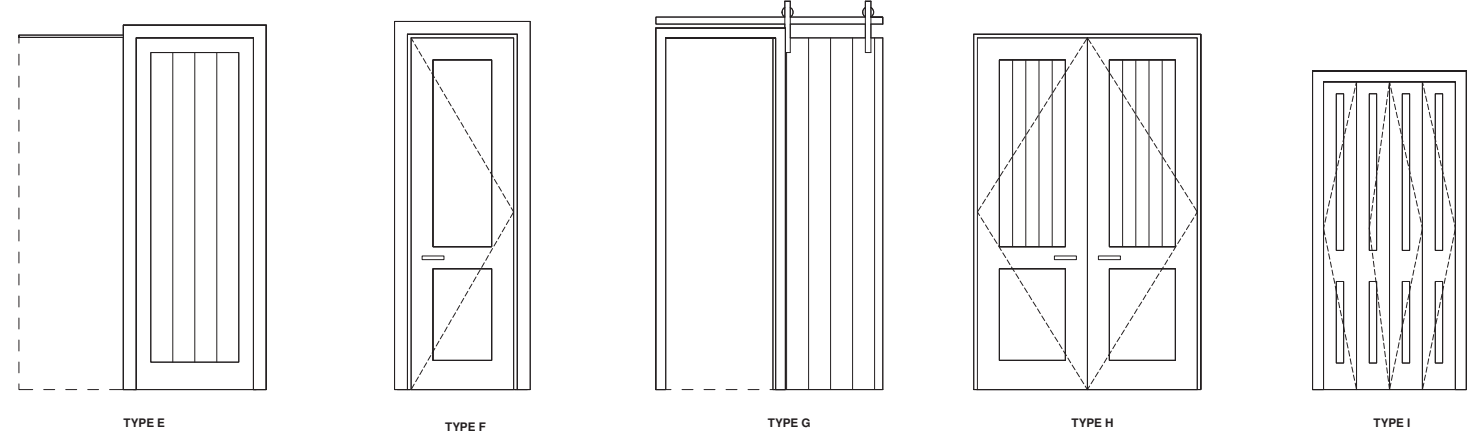

**INTERIOR DOOR TYPES**  
1/2" = 1'-0"

**WINDOW DETAIL W/ STONE VENEER**  
1 1/2" = 1'-0"

WINDOW SCHEDULE				
TYPE	TYPE	Count	UNIT WIDTH	UNIT HEIGHT
Casement	A	7	2' - 0"	2' - 0"
Casement	B	6	2' - 6"	5' - 0"
Casement 2-Wide	C	5	5' - 0"	5' - 0"
Casement 3-Wide	D	1	7' - 6"	5' - 0"
Casement	E	2	2' - 0"	3' - 6"
Casement	F	2	2' - 6"	4' - 0"
Casement	G	3	2' - 6"	3' - 6"
Casement 3-Wide	H	1	7' - 6"	3' - 6"
Casement 2-Wide	I	3	5' - 0"	4' - 0"
AWNING (2 WIDE)	J	2	5' - 0"	2' - 0"
Casement	K	2	2' - 0"	4' - 0"

- WINDOW NOTES**
1. VERIFY ROUGH OPENINGS WITH MANUFACTURER PRIOR TO FRAMING.
  2. WINDOW MANUFACTURER TO VERIFY WINDOW SWINGS.
  3. WINDOW MANUFACTURER TO PROVIDE SHOP DRAWINGS.
  4. PROVIDE SCREENS FOR ALL OPERABLE WINDOWS.

- DOOR NOTES**
1. NEW EXTERIOR DOORS TO BE 2/3 LITE PER GS#34.
  2. DOOR HARDWARE TO BE BRUSHED NICKEL OR BRUSHED STEEL.
  3. DOOR & WINDOW MANUFACTURER: LOEWEN ALUMN CLAD WOOD OR SIMILAR.
  4. VERIFY ROUGH OPENINGS WITH MANUFACTURER PRIOR TO FRAMING.

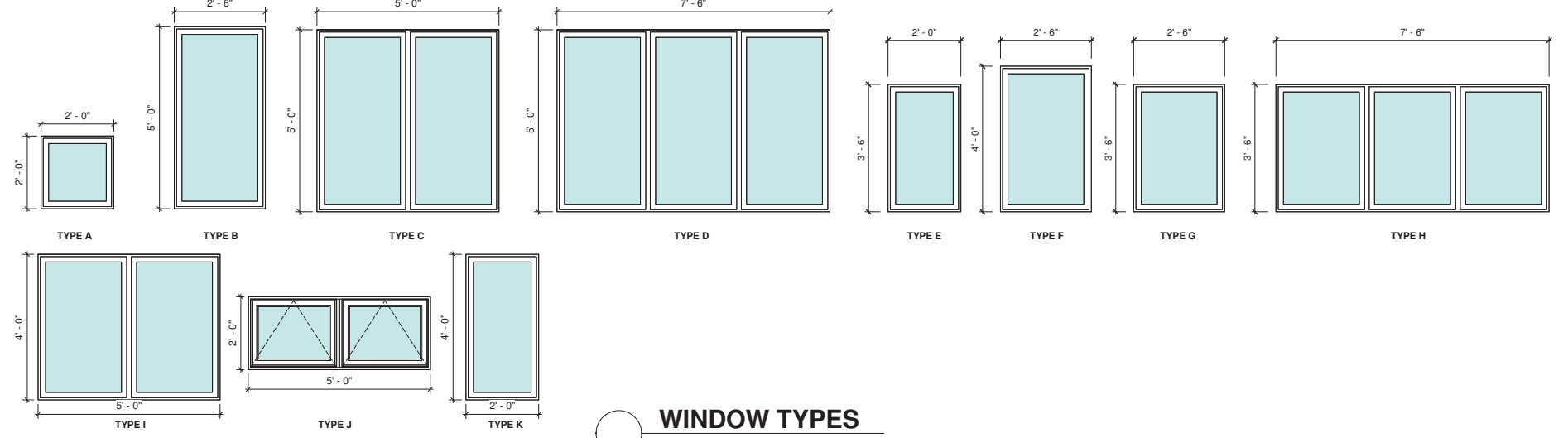
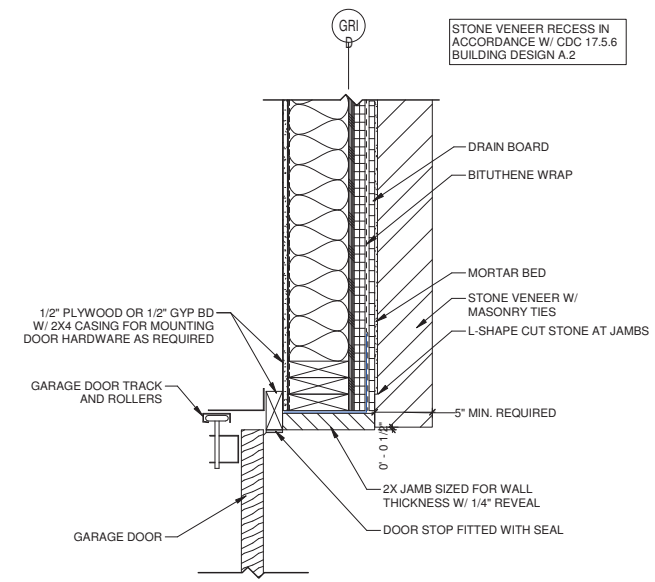

**WINDOW TYPES**  
1/2" = 1'-0"

**GARAGE DOOR JAMB @ STONE VENEER**  
1 1/2" = 1'-0"

- LIGHTING NOTES:**
1. FIELD VERIFY ALL LIGHTING LOCATIONS.
  2. TYPICAL LIGHTING LOCATION AT STAIRS:  
(1 EA) PER LANDING  
(2 EA) PER RUN
  3. CONTRACTOR SHALL TAKE CARE IN PLANNING ROUGH FRAMING LAYOUT AS IT RELATES TO THE NEED TO CENTER FIXTURES IN HALLWAYS, RECESSES AND OTHER AREAS WHERE RELATIONSHIPS DON'T OFFER ANY LATITUDE OR FIELD ADJUSTMENTS.
  4. ALL RECESSED FIXTURES AT INSULATED CEILINGS TO BE IC RATED AND CERTIFIED AIR TIGHT CONSTRUCTION. ALL EXTERIOR FIXTURES, SHOWER FIXTURES AND FIXTURES OVER TUBS TO BE MARKED "SUITABLE FOR DAMP LOCATIONS".
  5. LIGHTING SHALL BE IN ACCORDANCE WITH TOWN OF MOUNTAIN VILLAGE COMMUNITY DEVELOPMENT CODE 17.5.12 LIGHTING REGULATIONS
  6. PROVIDE FULL CUT OFF FIXTURES WITH LED 10W 2500K-2700K BULBS PER CDC REQUIREMENTS.
  7. MOUNT FIXTURES AT 7'-0" AFF MAX PER CDC REQUIREMENTS.
  8. EXTERIOR LIGHTING ON SECOND AND UPPER FLOORS SHALL REQUIRE EITHER A TIMER OR SENSOR TO REDUCE USAGE AND ENERGY LOSS DURING TIMES OF INACTIVITY.

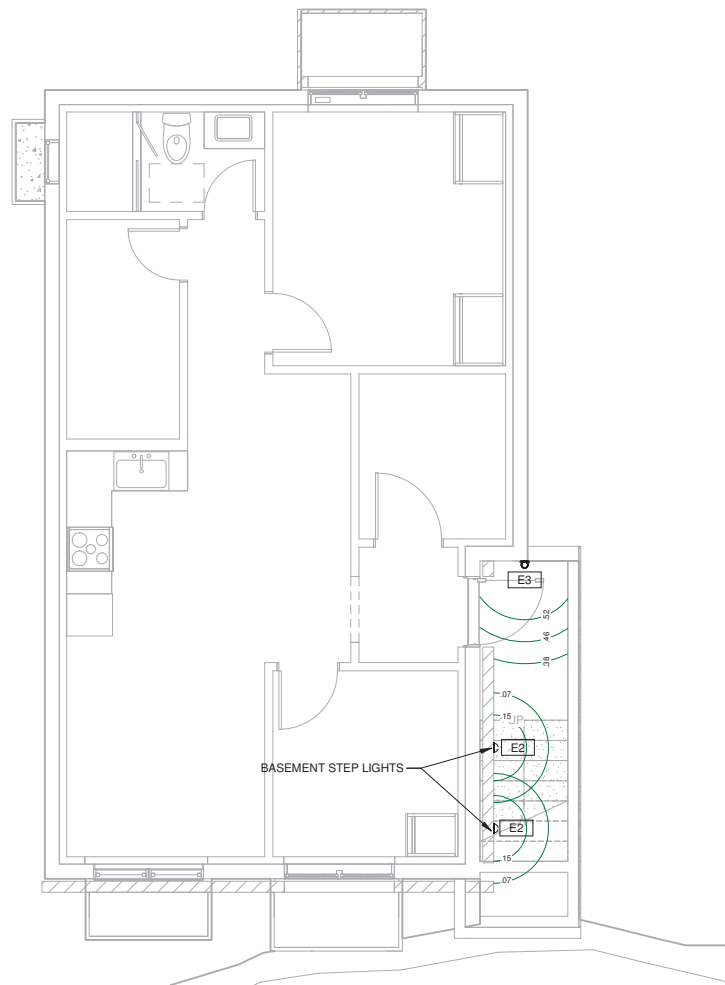

**2 BASEMENT EXTERIOR LIGHTING PLAN**

1/4" = 1'-0"

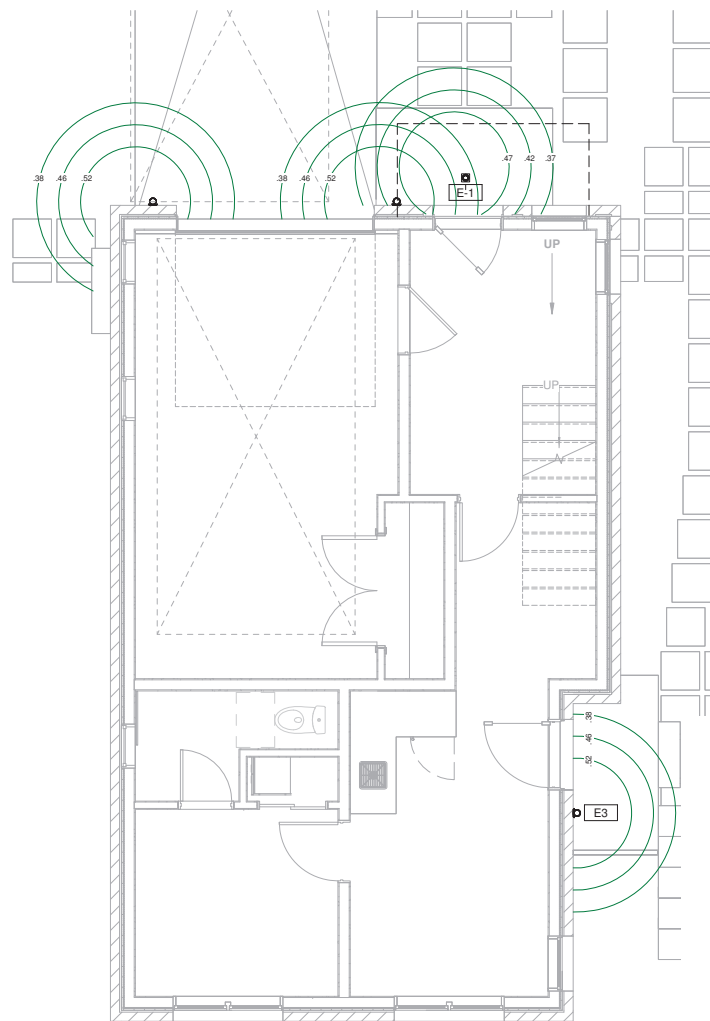

**1 LOWER LEVEL EXTERIOR LIGHTING PLAN**

1/4" = 1'-0"



**EXTERIOR E-1:**  
EXTERIOR RECESSED LED CAN

TESLA PRO 2	
FINISH: BRUSHED NICKEL	
MANUFACTURER	WAC LIGHTING
ITEM	WAC514031
MATERIAL	DIE-CAST ALUMINIUM
GLASS	ETCHED LENSE
WIDTH	4.25" DIA.
HEIGHT	4.25" DIA.
DEPTH	.13"
LAMP TYPE	LED
BULB TYPE	14.5W
LUMENS	535
COLOR TEMPERATURE	2700K
CRI	85
RATED LIFE	90,000 HOURS
CERTIFICATION	IP66, UL & cUL LISDTED FOR WET LOCATIONS
DARK SKY	YES
VOLTAGE	120V, DIRECT WIRING



**EXTERIOR E-2:**  
EXTERIOR STEP AND WALL LIGHT

LANDSCAPE LIGHTING LED HORIZONTAL STEP LIGHT	
FINISH: BLACK	
MANUFACTURER	WAC LIGHTING
ITEM	WAC671977
MATERIAL	CORROSION RESISTANT ALUMINIUM
GLASS	ETCHED LENS
WIDTH	5"
HEIGHT	3"
DEPTH	.13"
LAMP TYPE	LED
BULB TYPE	3.9W
LUMENS	68
COLOR TEMPERATURE	3000K
CRI	83
RATED LIFE	60,000 HOURS
CERTIFICATION	UL LISTED FOR WET LOCATIONS
DARK SKY	YES
VOLTAGE	120V, DIRECT WIRING



**EXTERIOR E-3:**  
EXTERIOR WALL SCONCE

PANDORA LED INDOOR/OUTDOOR WALL SCONCE	
FINISH: BRONZE	
MANUFACTURER	MODERN FORMS
ITEM	MF1720529
MATERIAL	ALUMINIUM
GLASS	LED DRIVER
WIDTH	7"
HEIGHT	7"
DEPTH	4.75"
LAMP TYPE	LED
BULB TYPE	12W
LUMENS	270
COLOR TEMPERATURE	3000K
CRI	85
RATED LIFE	50,000 HOURS
CERTIFICATION	ADA COMPLIANT & ETL LISTED WET
DARK SKY	YES
VOLTAGE	120V, DIRECT WIRING

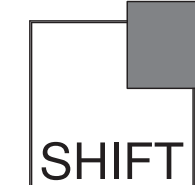

P.O. Box 3206  
100 W. Colorado Suite 211  
Telluride, Colorado 81435  
p 970-728-8145  
kristine@shift-architects.com  
www.shift-architects.com

PROJECT ISSUE DATE:  
10.14.24 REVISED FINAL DRB  
SUBMITTAL

**SERENITY MV**

Unit-10, Boulders Way, Mountain Village  
Telluride, CO 81435, USA

LIGHTING PLANS

©shift architects

SHEET NUMBER

10/14/2024 2:05:20 PM

**LTG1.1**

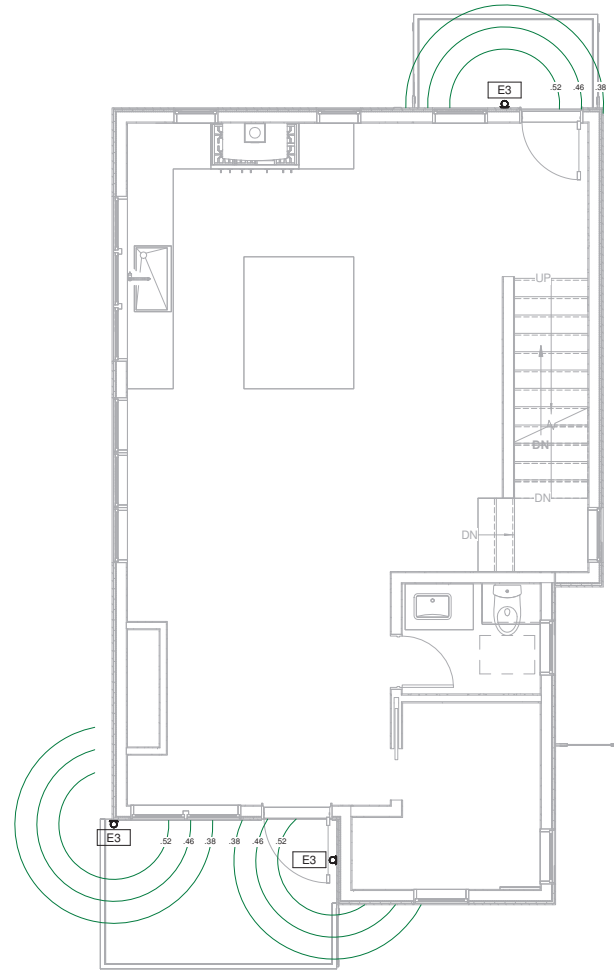

**1 MAIN LEVEL EXTERIOR LIGHTING PLAN**  
 1/4" = 1'-0"

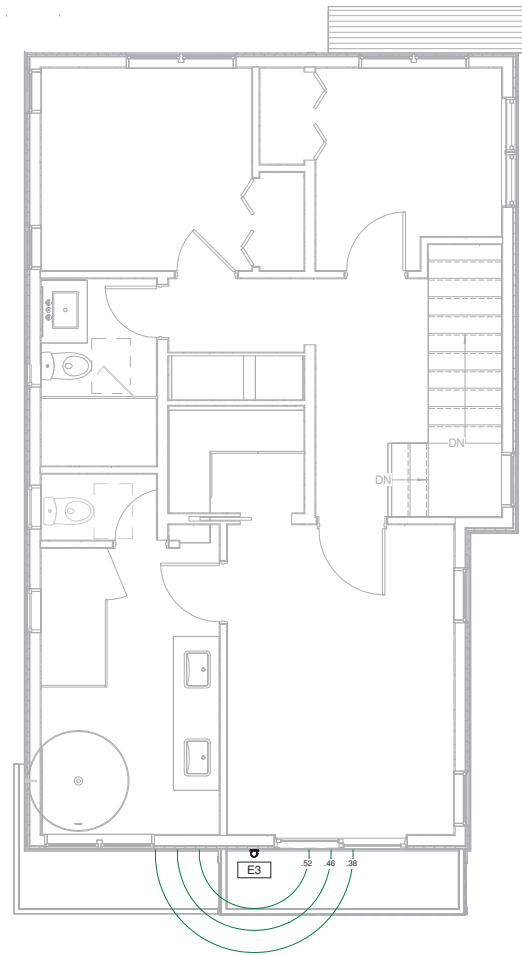

**2 UPPER LEVEL EXTERIOR LIGHTING PLAN**  
 1/4" = 1'-0"

**SERENITY MV**

Unit-10, Boulders Way, Mountain Village  
 Telluride, CO 81435, USA

LIGHTING PLAN

SHEET NUMBER

©shift architects

**LTG1.2**

10/14/2024 2:05:20 PM

# 10 Boulders Way Construction Mitigation Narrative

By Daniel Oldmixon  
10-21-24

Area of Construction,  
Fence around  
perimeter

3' x 3' Bear Proof  
Trash Container for  
Food Located on Site



Construction Debris  
and Trash to be  
Hauled as needed  
from site by dump  
trailer

Material Staging on  
site

Construction Fence

Portalet (on site)

Proposed Construction  
Parking + Excess  
Material Staging



To fully understand the construction mitigation plan for the work on Lot 10 Boulders Way it is important to understand the process for construction. To begin a chain link fence will be installed around Lots 10 and 11 collectively as the excavation and foundation work will be performed on both sites simultaneously. Then excavation will begin in order to prep for concrete and utility work. The utilities and fill materials will be staged on site only. The concrete forming materials and rebar will be staged only on site. Job site parking and added material staging will be on empty lots of the boulders as allowed. Overflow parking will be at the Big Billy's parking lot. All trash will be removed from site using a dump trailer and there will not be a construction dumpster on site. All interior building materials will be staged in the house. All exterior building materials will be staged on the site.



**TO:** Mountain Village Design Review Board  
**FROM:** Drew Nelson, Senior Planner  
**FOR:** Design Review Board Public Hearing; November 7, 2024  
**DATE:** October 30, 2024  
**RE:** Staff Memo – Initial Architecture and Site Review (IASR) Lot 165 Unit 17R, TBD Cortina Drive, pursuant to the CDC

**APPLICATION OVERVIEW: New Multi-Family on Lot 165 Unit 17R**

**PROJECT GEOGRAPHY**

**Legal Description:** Unit 17R, Second Amendment to the map of the Cortina Land Condominiums (115 Cortina Drive). Located in the SE Quarter of Section 3, Township 42 N, Range 9 W of the New Mexico principal meridian  
**Address:** TBD Cortina Drive  
**Applicant/Agent:** David Schiltz, BCW Properties LLC  
**Owner:** BCW Properties LLC  
**Zoning:** Multi-Family  
**Existing Use:** Vacant  
**Proposed Use:** Multi-Family  
**Lot Size:** 8,721 square feet (0.200 Acres)

**Adjacent Land Uses:**

- **North:** Multi-Family
- **East:** Multi-Family
- **West:** Multi-Family
- **South:** Multi-Family

**ATTACHMENTS**

Exhibit A: Architectural Plan Set  
Exhibit B: Staff/Public Comments

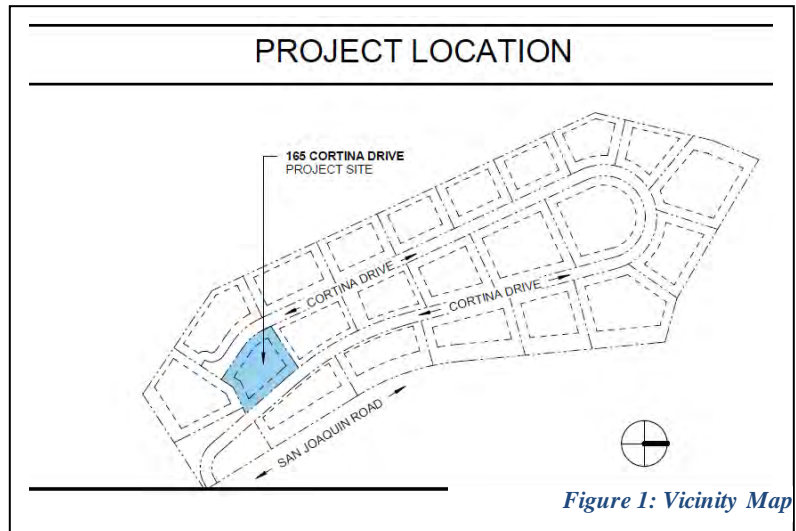

*Figure 1: Vicinity Map*

**Case Summary:** David Schiltz of BCW Properties LLC is requesting Design Review Board (DRB) approval of an Initial Architectural and Site Review (IASR) application for a new multi-family development on Lot 165 Unit 17R, TBD Cortina Drive.

The proposed structure is a four-story multi-family development and utilizes a gabled roof form. The lot is approximately 8,721 livable square feet and is zoned multi-family. This proposal was originally approved by the DRB in early 2023, and this application consists of a significant change to layout and access. The proposed building is designed with garage access off the upper portion of Cortina Drive (the previous design utilized access off the lower portion of Cortina Drive). The previous design was three stories, with a lower-level garage included in the design. The building form steps back into the hillside to help maintain building height and building siting requirements.

This lot was part of a phased development at Cortina, originally called Cortina Phase 2 that had gone through design approvals and was just in the beginning phases of construction when it was abandoned in 2012.

**Applicable CDC Requirement Analysis:** The applicable requirements cited may not be exhaustive or all-inclusive. The applicant is required to follow all requirements even if an applicable section of the CDC is not cited. ***Please note that Staff comments will be indicated by Italicized Text.***

*Table 1: Relevant information from CDC Sections 17.3.11-14; 17.5.6 (materials); 17-5.8 (parking)*

<b><u>CDC Provision</u></b>	<b><u>Requirement</u></b>	<b><u>Proposed</u></b>
<b>Maximum Building Height</b>	53' (gabled) Maximum	52'10"
<b>Avg. Building Height</b>	53' Maximum	40'7"
<b>Maximum Lot Coverage</b>	65%	51%
<b>General Easement Setbacks</b>	No encroachment	GE Encroachment
<b>Roof Pitch</b>		
Primary		2 1/2":12"
Secondary		1 3/8":12"
<b>Exterior Material</b>		
Stone	35% minimum	36%
Windows/Door Glazing	40% maximum	27%
Steel	n/a	23%
Wood	n/a	13%
<b>Parking</b>	1.5 spaces per unit	6 spaces (2 per unit)

*Specific Approval(s):*

- *Tandem Parking*
- *Composite Wood Siding for Fascia*

*Design Variation:*

- *Loading/Unloading Area Parking Space Size*

## **Chapter 17.3: ZONING AND LAND USE REGULATIONS**

### **17.3.7: Density Limitation**

*Staff: The proposed development contains three condominium units. According to Section 17.3.7 of the CDC, one unit is equal to 3.0 persons equivalent. This means that the*

proposed development results in 9.0 persons equivalent for density calculations. The official Town Density list shows that this density is reserved on the lot and shown as unbuilt.

### **17.3.11 and 17.3.12: Building Height and Building Height Limits**

Sections 17.3.11 and 17.3.12 of the CDC provide the methods for measuring maximum building height and average building height, along with providing the height allowances for specific types of buildings based on their roof form. The proposed design incorporates gable roof forms, with a secondary shed roof for a portion of the structure. Multi-family developments are granted a maximum height of 48 feet with an additional 5 feet for gabled roof forms for a total of 53 feet. The average height is an average of measurements from a point halfway between the roof ridge and eave. The maximum height is measured from the highest point on a roof directly down to the existing grade or finished grade, whichever is more restrictive.

*Staff: Staff has determined that the primary roof form for this home is gabled and therefore granted a maximum height of 53' and an average maximum height of 53' for a multi-family development. According to the design set, the applicant has calculated a maximum height of 52'10" and an average height of 47'7". The applicant has provided a 3D planar view of 53' projected from the natural grade and the proposed grade in comparison to the highest point of the structure shown in Figure 2. The applicant has proposed a height measurement that purports to meet the height requirements of the CDC.*

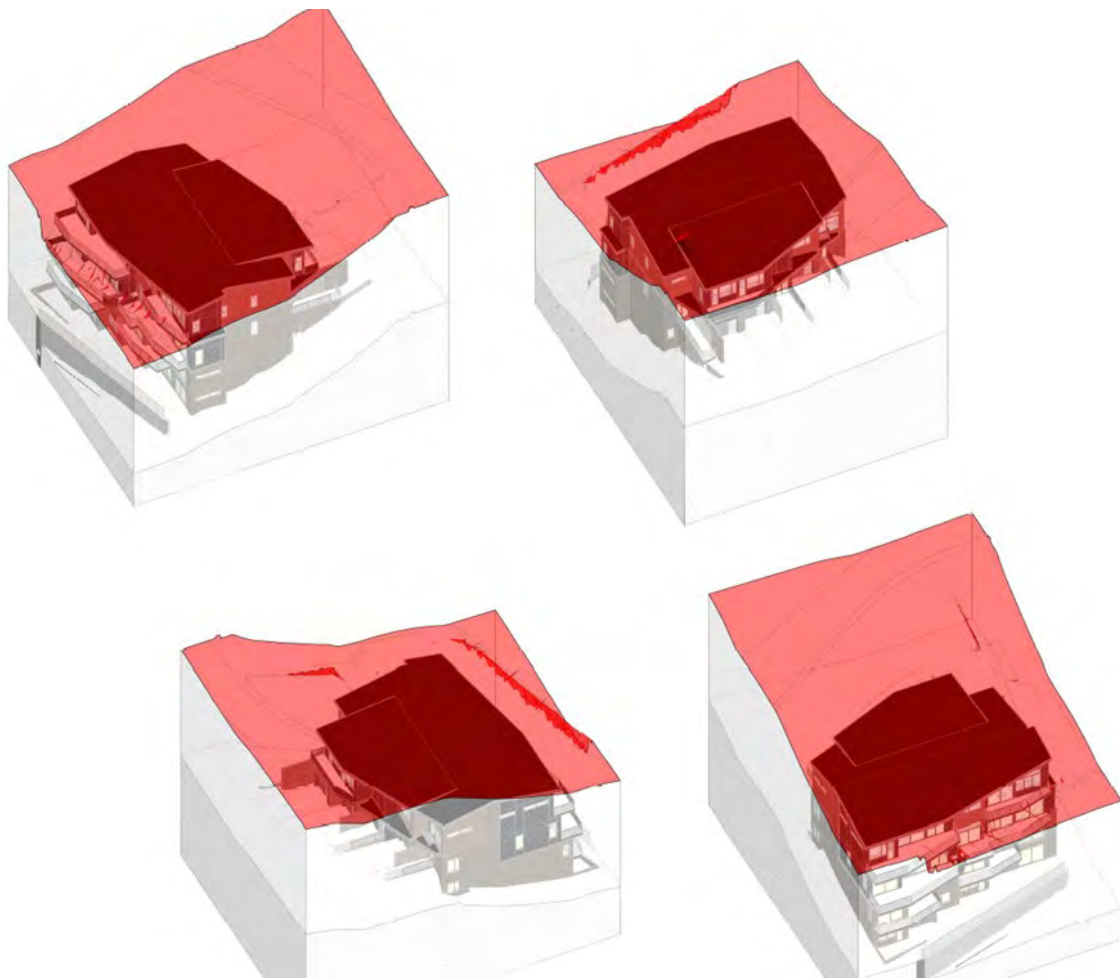

*Figure 2: Height Analysis 3D Planar View*

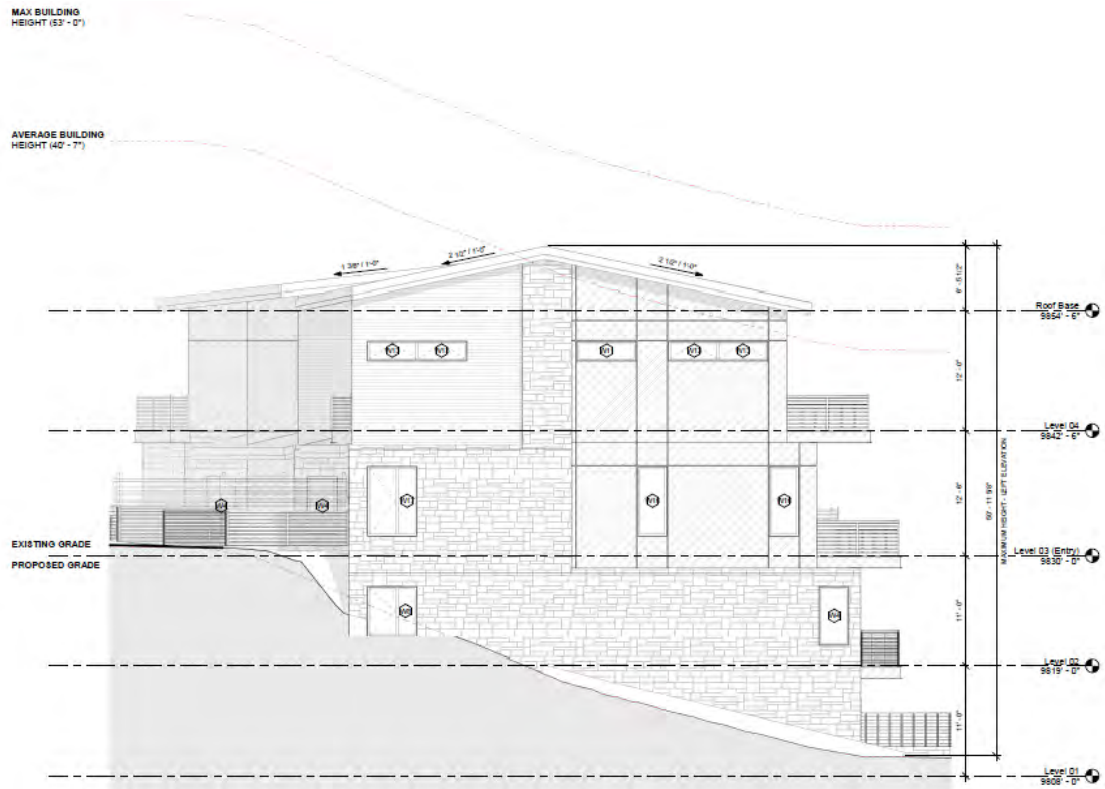

Figure 3: South Elevation - Height

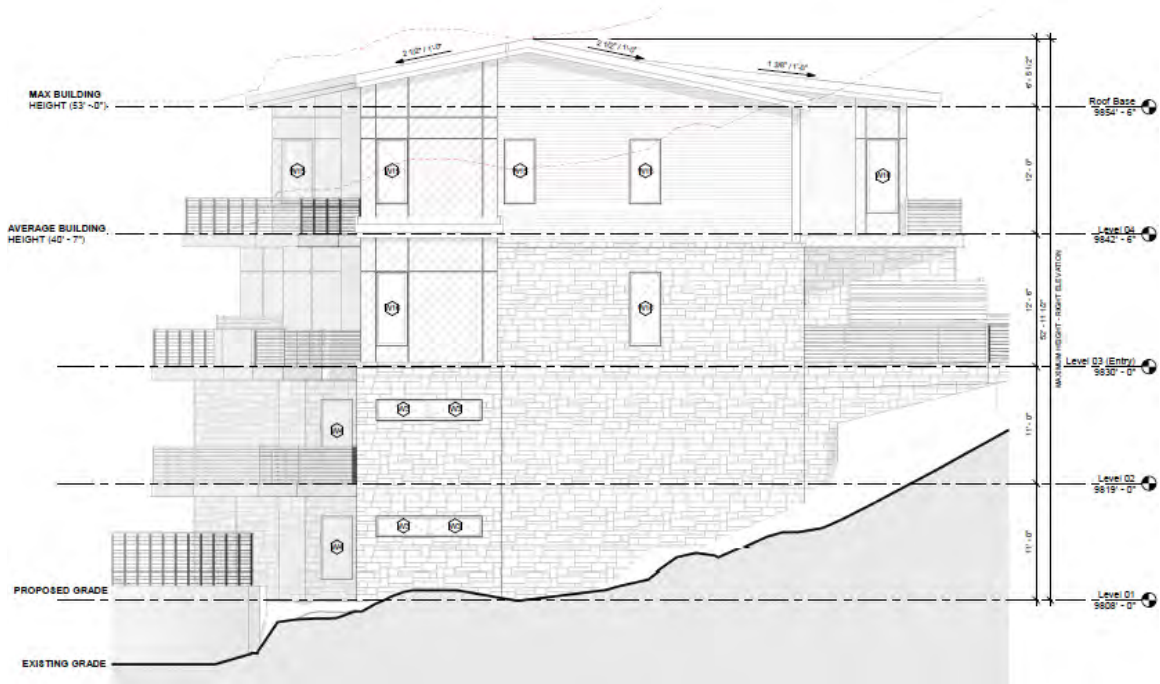

Figure 4: North Elevation- Height





Figure 5: West Elevation - Height

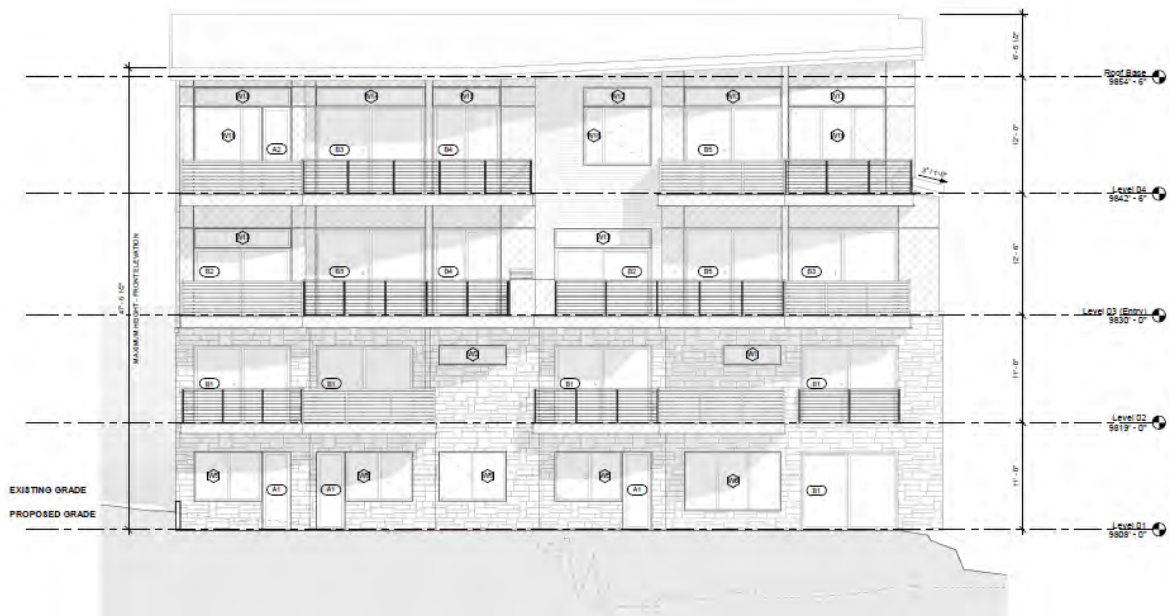

Figure 6: East Elevation - Height

### 17.3.14: General Easement Setbacks

The CDC provides that the General Easement and other setbacks be maintained in a natural, undisturbed state to provide buffering to surrounding land uses. The CDC does provide for some development activity within the GE and setbacks such as driveways, ski access, natural landscaping, utilities, address monuments, and fire mitigation. There are no General Easements on the property; however, there are numerous utility and access easements that exist to the benefit of the Homeowner's Association.

*Staff: There are some encroachments in the setbacks including the following:*

- *Driveway: The driveways to each unit are proposed to extend across the property line, with tandem parking spaces proposed to meet the .5-space deficiency for each unit. Tandem parking spaces are proposed for each unit, which requires a Specific Approval from the DRB.*
- *Utilities: Utilities are proposed to be accessed from the lower Cortina Drive area below the proposed units. Adequate facilities exist for utility service to the property.*

The applicant is proposing to install access to the front door of one of the units across the pedestrian and skier access easement on the property. The applicant will need to receive permission from the respective HOAs within the Cortina subdivision to either vacate the easement or have explicit approval to modify the existing conditions within the easement. This has been made a condition of Final Architecture Review. The applicant has requested relief from the Town for this easement; however, the Town is not a party to the easement so approval will need to be from the beneficiaries of the easement (i.e. the HOA), which is listed as a condition to be addressed prior to Final Architecture Review.



Figure 7: Easement Encroachment

## Chapter 17.5: DESIGN REGULATIONS

### 17.5.4: Town Design Theme

The Town of Mountain Village has established design themes aimed at creating a strong image and sense of place for the community. Due to the fragile high alpine environment, architecture and landscaping shall be respectful and responsive to the tradition of alpine design – reflecting elements of alpine regions while blending influences that visually tie the town to mountain buildings. The town recognizes that architecture will continue to evolve and create a regionally unique mountain vernacular, but these evolutions must continue to embrace nature and traditional style in a way that respects the design context of the neighborhoods surrounding the site.

*Staff: The proposed development reflects the design goals of the Town of Mountain Village as outlined in section 17.5.4 of the CDC. The massing steps with the natural topography, in this case a steep slope. The materials chosen are a combination of stone, steel and wood, which creates an exterior capable of withstanding the high alpine environment.*

*Overall, it appears that the design is visually appealing and would fit within the existing Mountain Village Design Theme.*

### **17.5.5: Building Siting Design**

The CDC requires that any proposed development blend into and protect to the extent possible the existing landforms and vegetation. The CDC requires that any proposed improvements on sites adjacent to open space are submitted to the owner of the affected open space for review and approval.

*Staff: The siting of the structure mimics the natural landscape of the site. Though the lot has a significant slope throughout, the use of horizontal elements blends the residence into the surrounding hillside. The proposed development is designed to step naturally with the significant grading on the site. Vehicular and pedestrian access is provided via the upper levels of the site, with the building stepping down the existing topography while providing pedestrian access on the higher side. The proposed topography is designed to integrate drainage measures but otherwise have a minimal impact to the existing topography. The development does not propose grading, clearing, direct drainage, direct access or other direct impact onto the adjoining lots.*



*Figure 8: Proposed Front/Uphill Elevation*



*Figure 9: Proposed Rear/Downhill Elevation*

### **17.5.6: Building Design**

The CDC requires that building form and exterior wall forms are well grounded to withstand extreme climate conditions, with the base of the building using materials that are appropriate to be adjacent to accumulated snowfall. Roof design elements that utilize multiple forms with varied ridgelines and vertical offsets and reflect concern for snow accumulation is required. The code permits rusted, black or gray standing seam or metal roofs. Doors and entryways must be constructed using handcrafted materials whenever possible and garage doors shall be recessed and visually interesting. Glazing must be responsive to the energy code and site conditions and cannot exceed a maximum façade coverage of 40 percent. The exterior color must be natural, warm and subtle and harmonize with the natural landscape.

*Staff: Staff comments regarding each of the relevant subsections are below.*

#### *Building Form:*

*The form of the proposed residential structure follows an alpine mountain design that is grounded to withstand the extreme natural forces of wind, snow, and heavy rain. The proposed use of the stone at the base of the structure along with the use of steel reinforces this requirement.*

#### *Exterior Wall Form:*

*The proposed development has exterior walls that are relatively simple in design and portray a massing that is substantially grounded to the site. This is reinforced through the use of stone materials as the base.*

#### *Roof Form:*

*The roof design is a single gabled roof form with a secondary shed roof. The roof will be made of dark gray non-reflective standing seam metal.*

#### *Chimneys, Vent and Rooftop Equipment Design:*

*The applicant has not identified whether fireplaces are proposed for the units; prior to Final Architecture Review, the applicant shall confirm whether fireplaces are proposed for the project and whether chimneys or flues will be proposed for the roof.*

#### *Exterior Walls Materials and Color:*

*The building utilizes stone veneer at the base of the home and around the garages. Wood siding is proposed on upper levels around the exterior of the building. Stone walls account for approximately 36 percent of exterior materials, which meets the minimum 35 percent stone requirement. The applicant has indicated that dark gray Hardie board (composite wood) will be used for the fascia, which requires a Specific Approval from the DRB.*

#### *Glazing:*

*The maximum window area of the building, including window and door glazing, is approximately 27 percent of the total building façade.*

#### *Doors and Entryways:*

*Sheet A5.01 of the design set shows the window and door schedules, as well as schedule for the three garage doors. Prior to Final Architecture Review, the applicant shall provide window design specifications to ensure that window recess requirements of the CDC are met.*

Decks and Balconies:

The proposed balconies enhance the overall architecture of the building by creating variety and detail on the exterior elevations as outlined in the CDC.

Required Surveys and Inspections:

As required by the CDC, the applicant shall be responsible for ensuring roof heights are being met by obtaining a survey to confirm overall ridge height. The applicant is proposing to construct the roofline within 2" of the allowable maximum roof height, which will require confirmation of conformance at the time of Final DRB Inspection.

**17.5.7: Grading and Drainage Design**

All multifamily, mixed-use, or commercial projects shall be required to provide a drainage study prepared by a Colorado professional engineer with storm water run-off calculations that determines the volume of run-off from impervious surfaces.

Staff: The applicant has provided a civil site plan indicating drainage swales on both the north and south sides of the structure, indicating that stormwater will drain away from the units. The applicant has also proposed stormwater dry wells on the northeast and southeast sides of the units to retain drainage. The proposal meets the standards of the CDC; however, the applicant should consider whether below-ground stormwater retention will be adequate in consideration of the size of the site.

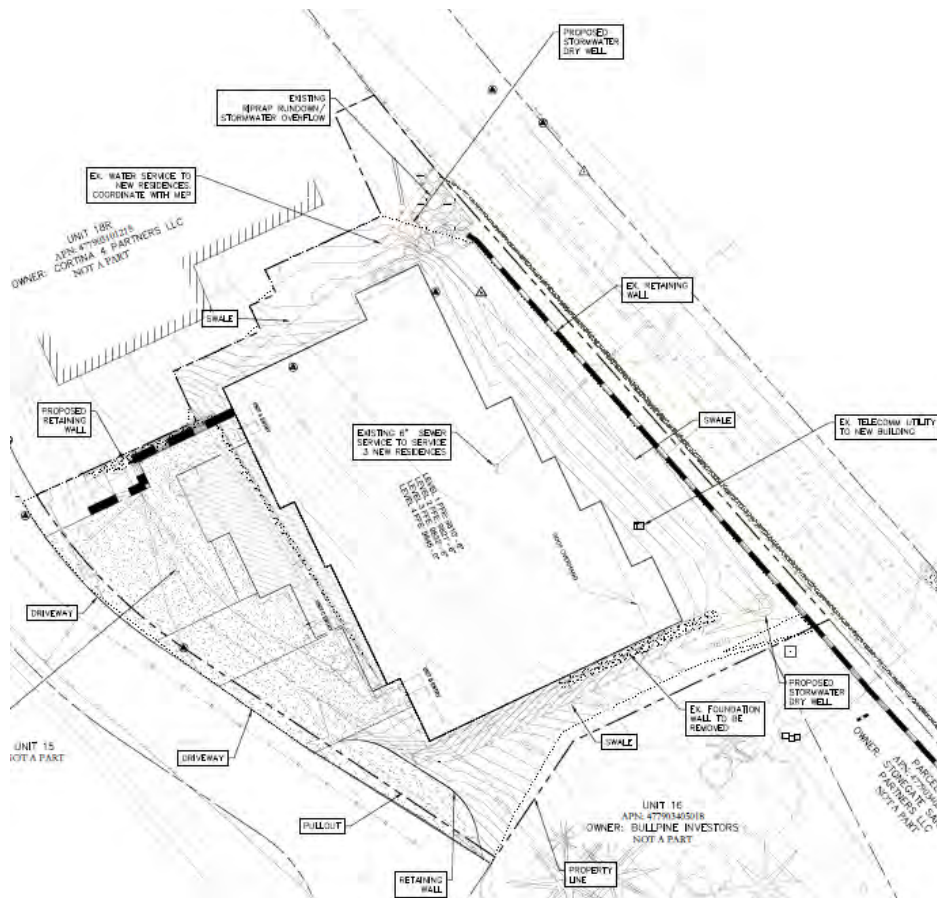

Figure 10: Grading Plan

### 17.5.8: Parking Regulations

Staff: The applicant has shown three interior and three exterior parking spaces per their plan. This meets the required 1.5 spaces per unit requirement; however, the applicant's proposal of tandem parking spaces requires a Specific Approval. Since the dimensions of the interior and exterior parking spaces were not shown, prior to Final Architecture Review the applicant shall verify that all parking spaces meet the required 9' x 18' size. CDC Section 17.5.8.C.10 requires loading and unloading space of 12 feet by 55 feet for multifamily development. The applicant is proposing a "parking pullout" for a delivery truck with dimensions of 10 feet by 22 feet, which does not meet the standards of the CDC and would require a Design Variation. The DRB should discuss whether a waiver of the delivery truck dimensions is suitable for management of the site, in conjunction with the location of the vehicle turnaround at the end of Cortina Drive.

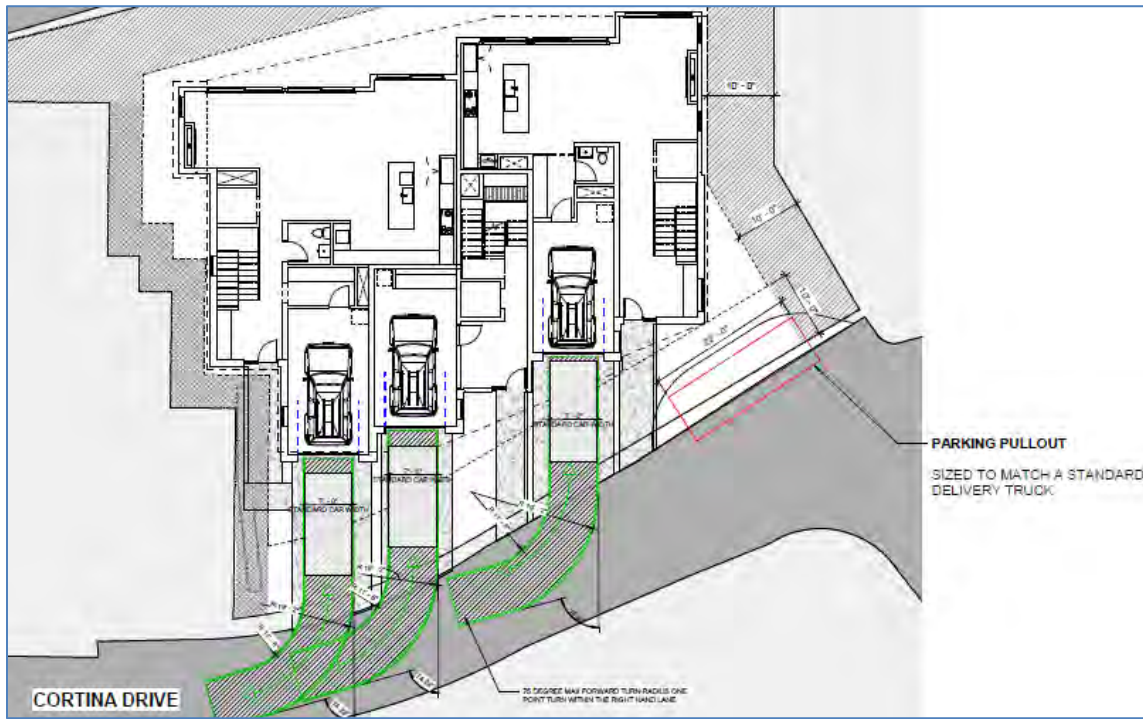

Figure 10: Proposed Parking

### 17.5.9: Landscaping Regulations

Staff: No landscaping plan was provided for the Initial Architecture and Site Review (it is a requirement of the Final Architecture Review plan set). Prior to Final Architecture Review, the applicant shall provide a landscape plan meeting the standards of the Community Development Code.

### 17.5.10: Trash, Recycling, and General Storage Areas

For all development, all trash containers shall be bear-proof, and trash and recycling containers shall be stored in an enclosure or garage as approved by the review authority. Locations and design for trash storage shall be indicated on the site plan. For multifamily or mixed-use developments, the minimal dimensions for trash and recycling enclosures shall be ten feet by twelve feet (10' x 12') if shared by more than four (4) units with a ceiling height of ten feet (10').

*Staff: The applicant has not provided information about trash and recycling areas within the unit, or a general servicing area on the exterior of the development. Prior to Final Architecture Review the applicant shall provide details on areas for trash, recycling, and general storage areas.*

#### **17.5.11: Utilities**

*Staff: Civil plans are included in the application and appear to meet the requirements of the CDC.*

#### **17.5.12: Lighting Regulations**

*Staff: The applicant has not provided a lighting plan for review in the design set, which is required at the time of Final Architecture Review. Prior to Final Architecture Review, the applicant shall provide a photometric lighting plan that meets the standards of the CDC.*

#### **17.5.13: Sign Regulations**

*Staff: The applicant has not provided any details on address monuments proposed for the site. Prior to Final Architecture Review, the applicant shall provide detailed information on address monumentation, including whether address monuments are proposed to be located on the wall of the building in conformance with Section 17.5.13.E.4.a.i of the CDC.*

### **Chapter 17.6: SUPPLEMENTARY REGULATIONS**

#### **17.6.1: Environmental Regulations**

*Staff: The applicant has not provided a wildfire mitigation plan. The following comments were received from the Town Forester:*

*The plan set titled 165 Cortina Drive Unit 17 R does not have a tree survey of existing trees, or a construction mitigation plan which is required by the CDC. The plan set titled 165 Cortina Drive Unit 17 R does not have a wildfire mitigation plan showing the fire mitigation zones or a landscape plan which are also required by the CDC. As a result, the Town Forester does not have enough information to make any comments about the proposed development for Lot 165 Unit 17R and as such cannot recommend it for approval.*

*Prior to Final Architecture Review, the applicant shall provide a fire mitigation and landscape plan as required by the CDC that addresses the comments of the Town Forester.*

#### **17.6.6: Roads and Driveway Standards**

*Staff: The driveways proposed for the individual units appear to be short and relatively flat, per the civil design plans shown on sheet C1.0. The civil plans do not indicate driveway slope, which needs to meet the grade requirements of Section 17.6.6.B.4 of the CDC. Prior to Final Architecture Review, the applicant shall provide driveway slope details to ensure compliance with the CDC of a maximum grade of eight percent (8%) overall and five percent (5%) for the first twenty feet (20') from the edge of the access tract.*

#### **17.6.8: Solid Fuel Burning Device Regulations**

*Staff: The applicant has not indicated whether a solid fuel fireplace is proposed for any of the units. If the applicant intends to have a wood burning fireplace, then a solid fuel burning permit must be provided to the Town per section 17.6.8.A of the CDC. Prior to Final Architecture Review, the applicant shall provide information on any proposed fireplaces for the residential units.*

## **Chapter 17.7: BUILDING REGULATIONS**

### **17.7.20: Construction Mitigation**

*Staff: A construction mitigation plan was not provided as part of the Initial Architecture and Site Review plan set. Prior to Final Architecture Review, the applicant shall provide a Construction Mitigation Plan in conformance with Section 17.7.20 of the Community Development Code.*

**Staff Note: It should be noted that reasons for approval or rejection should be stated in the findings of fact and motion.**

#### **Proposed Motion:**

If the DRB deems this application to be appropriate for approval, Staff requests said approval condition the items listed below in the suggested motion.

*I move to approve the Initial Architecture and Site Review for three (3) new multifamily condominium residences located at Lot 615 Unit 17R, based on the evidence provided in the staff record of memo dated October 30, 2024, and the findings of this meeting with the following Specific Approvals, Design Variations and Conditions:*

#### *Specific Approval(s):*

- 1) Tandem Parking*
- 2) Composite Wood Siding for Fascia*

#### *Design Variation:*

- 1) Loading/Unloading Area Parking Space Size*

#### *Conditions:*

- 1) Prior to final review, shall provide evidence of approval of the entry to Unit A encroaching into the five-foot (5') easement surrounding the property by any beneficiaries of the ski and pedestrian easement as recorded on the Cortina subdivision plat.*
- 2) Prior to Final Architecture Review, the applicant shall confirm whether fireplaces are proposed for the project and whether chimneys or flues will be proposed for the roof.*
- 3) Prior to Final Architecture Review, the applicant shall provide window design specifications to ensure that window recess requirements of the CDC are met.*
- 4) Prior to Final Architecture Review the applicant shall verify that all parking spaces meet the required 9' x 18' size.*
- 5) Prior to Final Architecture Review, the applicant shall provide a landscape plan meeting the standards of the Community Development Code.*
- 6) Prior to Final Architecture Review the applicant shall provide details on areas for trash, recycling, and general storage areas.*
- 7) Prior to Final Architecture Review, the applicant shall provide a photometric lighting plan that meets the standards of the CDC.*
- 8) Prior to Final Architecture Review, the applicant shall provide detailed information on address monumentation, including whether address monuments are proposed to be located on the wall of the building in conformance with Section 17.5.13.E.4.a.i of the CDC.*
- 9) Prior to Final Architecture Review, the applicant shall provide a fire mitigation and landscape plan as required by the CDC that addresses the comments of the Town Forester.*
- 10) Prior to Final Architecture Review, the applicant shall provide driveway slope details to ensure compliance with the CDC of a maximum grade of eight percent*



- (8%) overall and five percent (5%) for the first twenty feet (20') from the edge of the access tract.*
- 11) Prior to Final Architecture Review, the applicant shall provide information on any proposed fireplaces for the residential units.*
  - 12) Prior to Final Architecture Review, the applicant shall provide a Construction Mitigation Plan in conformance with Section 17.7.20 of the Community Development Code.*
  - 13) The structure shall require a monitored NFPA 72 alarm system and monitored NFPA 13D sprinkler system.*
  - 14) A Knox Box for emergency access is recommended.*
  - 15) Consistent with town building codes, unenclosed accessory structures attached to buildings with habitable spaces and projections, such as decks, shall be constructed as either non-combustible, heavy timber or exterior grade ignition resistant materials such as those listed as WUIC (Wildland Urban Interface Code) approved products.*
  - 16) Prior to the Building Division conducting the required framing inspection, a four-foot (4') by eight-foot (8') materials board will be erected on site consistent with the review authority approval to show:
    - a. The stone, setting pattern and any grouting with the minimum size of four feet (4') by four feet (4');*
    - b. Wood that is stained in the approved color(s);*
    - c. Any approved metal exterior material;*
    - d. Roofing material(s); and*
    - e. Any other approved exterior materials**
  - 17) It is incumbent upon an owner to understand whether above grade utilities and town infrastructure (fire hydrants, electric utility boxes) whether placed in the right of way or general easement, are placed in an area that may encumber access to their lot. Relocation of such above grade infrastructure appurtenances will occur at the owner's sole expense and in coordination with the appropriate entity (fire department, SMPA, Town of Mountain Village) so that the relocated position is satisfactory.*

## **Design Narrative – Lot 17R Cortina**

### **Attached:**

Exhibit 01 – Design Package

Exhibit 02 – HOA Approval Letter

Exhibit 03 – Access Easement – Variance Request

Exhibit 04 – Soils Report

Exhibit 05 – ALTA Survey

Exhibit 06 – Steep Slope Analysis

This design narrative addresses the how the proposed development at Lot 17R Cortina is in compliance with the Mountain Village Municipal Code, specific to the Community Development Code (CDC) requirements. Lot 17R Cortina Drive is designed as a 3-unit condominium residence. The proposed building is designed with garages and individual unit entries provided at level 03 along the upper portion of Cortina Drive. Two (2) three-story units step down from level 03 to level 01, with level 01 set to walk out on grade above the existing lower Cortina Drive retaining wall. A third unit steps up from level 03 and spans across the footprint of the building at level 04. The building form as a whole is designed to step back into the hillside to help maintain building height and building siting requirements.

359 Design crafts projects that are architecturally contextual to not only blend with the surroundings but enhance the landscape. We have been working with mountain and destination jurisdictions since inception to create livable communities. We are committed to the mission of maintaining existing community standards while improving guest options for the future. 359 Design is also a leader in construction efficiency, with 100's of systems-built units under our belts. We know the sequence and how, when done properly, systems-built construction minimizes the impact on the surrounding community while maintaining efficiency.

### **Section 17.3.2 – Zone Districts Established**

B.4. Multifamily Zone District – The Multifamily Zone District (“MF”) is intended to provide higher density multifamily uses limited to multifamily dwellings, hotbed development, recreational trails, workforce housing and similar uses.

17.3.4.D.1 – Lots in the Multifamily Zone District shall be used for the construction of multifamily dwellings, including lodge units, efficiency lodge units, condominium units (attached or detached), workforce housing units, hotel units, hotel efficiency units, accessory commercial uses as limited below and other similar uses.

17.3.4.D.3 – Permitted accessory uses include home occupations pursuant to the Home Occupation Regulations, surface parking as limited by the Parking Regulations, and other similar uses.

### **Section 17.3.7 – Density Limitation**

C. The person-equivalent density is calculated based on the actual unit-to-person equivalent density conversion factors listed in Table 3-2:

Zoning Designation	Actual Unit	Person-Equivalent Density
Condominium	1	3.0 Person Equivalents

*The proposed development has a total of three (3) condominium units. Per Table 3-2 above, the person-equivalent density of the proposed development is 9.0.*

**Section 17.3.11 – Building Height**

B. The Building Height shall be measured from the highest point on the rooftop, roof ridge, parapet, or topmost portion of the structure (including but not limited to the roofing membrane) to the natural grade or finished grade, whichever is more restrictive, located directly below the highest point of the structure. A building height calculation is produced for each of the four (4) architectural elevations.

*Please refer to sheets A2.06, A2.08, and A9.01-A9.02 of the attached Exhibit 01 for a review of Building Height. The proposed development is conforming with all building height requirements. Per Table 3-3 and footnote 1 (the roof form is predominantly gable), the maximum building height for Multifamily Zoning is 53’ – 0”. As noted on Sheet A2.06, the maximum building height is 52’ – 10”.*

*Per Table 3-3 footnote 1; The ridge of a gable, hip, gambrel, or similar pitched roof may extend the maximum building height up to five (5) feet above the specified height limit, except on ridgeline lots.*

*Per Table 3-3 footnote 2; Chimneys, flues, vents, or similar structures may extend up to five (5) feet above the specified maximum height excluding unscreened telecommunications antenna with the height of such structures set forth in the telecommunications antenna regulations.*

C. The Average Building Height shall be measured from the natural grade or finished grade, whichever is more restrictive, to the point on the roof plane midway between the eave and the highest point on the rooftop, roof ridge, parapet, or topmost portion of the structure. An average building height calculation is produced for each of the four (4) architectural elevations. The four (4) height calculations are then averaged to derive the Average Building Height.

*Please refer to sheet A1.15 of the attached Exhibit 01 for a review of Average Building Height. The proposed development is conforming with all average building height requirements. Per Table 3-3 and footnote 1 (the roof form is predominantly gable), the maximum average building height for Multifamily Zoning is 53’ – 0”. As noted, the maximum average building height is 40’ – 7”.*

**Section 3.13 – Maximum Lot Coverage**

A. Maximum lot coverage for buildings in all zone districts is set forth in Table 3-4:

Zone District	Maximum Lot Coverage
Multifamily outside of the Village Center	65%

*Per Table 3-4 as noted above, the maximum lot coverage is 65%. As noted on sheet A0.00 of the attached Exhibit 01, the proposed lot density is 51%.*

### **Section 17.3.14 – General Easements Setbacks**

C. All general easement setbacks or other setbacks shall be maintained in a natural, undisturbed state to provide buffering to surrounding land uses and to maintain the ability to conduct any of the general easement allowed uses.

D. All above-grade and below-grade structures or structural components (soil nailing, etc.), earth disturbance, or ground level site development such as walks, hardscape, terraces and patios shall be located outside of the general easement setback or other setbacks on each lot within the allowable building area of a lot.

*Please refer Exhibit 02. The proposed development is requesting a design variance to encroach on the 5' – 0" setback as noted. Outside of the location noted, there are no proposed setback encroachments.*

### **Section 17.5.5 – Building Siting Design**

A. Effective site planning is crucial to designing a building and development that blends into the existing landscape. Building siting shall respect and relate to existing landforms and vegetation. Design solutions shall be site-specific, organizing the building mass in a way that relates to the terrain and functional constraints of the site.

*Please refer to sheets A1.02, A2.01 – A2.08, and A9.20 – A9.21 of the attached Exhibit 01. The proposed development is designed to step naturally with the significant grading on the site. Vehicular and pedestrian access are provided on the high side of Cortina Drive, with the building stepping back into the existing topography with walkout conditions above the existing lower Cortina Drive retaining wall at Level 01. The proposed topography is designed to integrate drainage measures but otherwise have a minimal impact to the existing topography.*

### **Section 17.5.6 – Building Design**

A. Building Form – The alpine mountain design shall be based on building forms that are well grounded to withstand the extreme natural forces of wind, snow, and heavy rain. All buildings shall be designed to incorporate a substantially grounded base on the first floor and at finished grade. Examples of materials which evoke this form are stone, metal, stucco, or wood. Where the base of a building meets natural grade, the materials must be appropriate to be adjacent to accumulated snow.

*Please refer to sheets A9.20 – A9.21 of the attached Exhibit 01. The proposed development is designed to integrally blend with the surrounding context. Stone is designed to ground the building as well as portions of the building as it rises to provide architectural continuity and density. Glazing and decks are designed to open to the strong views to the east, with secondary glazing and access provided on the west elevation where appropriate. Glazing on the north and south elevations is largely limited to enhance privacy while providing natural ventilation and daylighting. A combination of metal and wood façade are also introduced on the upper levels of the building to enhance the form and character of the proposed building as it rises out of the hillside.*

C.1. Roof Design Elements – The roof shall be a composition of multiple forms that emphasize sloped planes, varied ridgelines, and vertical offsets. The design of roofs shall reflect concern for snow accumulation and ice/snow shedding. Entries, walkways, and pedestrian areas shall be protected from ice/snow shedding.

*Please refer to sheet A1.15 of the attached Exhibit 01. The roof form of the proposed development is predominantly gable as noted. Snow guards have been noted to provide protection below. Pedestrian pathways are proposed to be snow-melted to mitigate ice concerns.*

C.2. Roof Drainage – All development within the Village Center shall be required to provide an integral guttering system designed into the roof or other DRB approved system of gutters, downspouts, and heat-tape to contain roof run-off. Within the Village Center, all building roof run-off shall be directed to storm-sewers or drainage systems capable of handling the volume of run-off. Such systems shall be kept and maintained by the owner and/or respective homeowners association in a clean, safe condition and in good repair.

*Please refer to sheet C1.0 of the attached Exhibit 01. The roof drainage system is designed to conform with all CDC and Village Center requirements.*

C.3. Roof Material – All roofing material shall be a type and quality that will withstand high alpine climate conditions. The review authority may require class A roofing materials as a fire mitigation measure.

*Please refer to sheets A2.01, A2.03, A2.05, and A2.07 of the attached Exhibit 01. The proposed roofing material is a dark gray non-reflective standing seam. This is in accordance with CDC 17.5.6.C.3.c.i.*

E. Exterior Wall Materials – A mix of materials including natural stone, stucco (only in the Village Center), steel, and wood shall be the primary exterior materials. Proposed exterior materials shall be compatible with surrounding area development.

E.1 Stone – All buildings with wood or other approved exterior materials shall have thirty-five percent (35%) minimum stone walls. A narrative that describes the pattern, grout, block size and color of the proposed stone and color picture of the proposed stone and setting pattern shall be provided as part of the Design Review Process application for approval by the review authority.

E.2 Wood – Wood siding (horizontal or vertical), wood shingles, log, log siding and heavy timbers, and timber veneers are acceptable exterior wood materials.

E.3 Metal – The review authority may review and approve metal as a siding material. Metal soffit material and fascia material require specific approvals in a development application. Permitted metal siding types include rusted corrugated, rusted sheet metal panels, zinc panels, copper panels, and other metal types reviewed and approved by the DRB.

G. Glazing – Window design must be responsive to the energy code and site conditions. Each window wall composition will be evaluated on the basis of whether it is an integral part of the structure's complete design. The maximum window area of a building shall be forty percent (40%) of the total building façade area. Window placement and size shall be sensitive to light spill to adjacent properties.

*Please refer to sheets A2.01 – A2.08 and A9.20 – A9.21 of the attached Exhibit 01. This documentation is intended to supplement the material board provided for review and approval by the review authority. The primary materials proposed are stone, wood, metal, and glazing. The proposed design meets all material requirements as outlined above and in the MV CDC.*

### **Section 17.5.7 – Grading and Drainage Design**

L. All multifamily, mixed-use, or commercial projects shall be required to provide a drainage study prepared by a Colorado professional engineer with storm water run-off calculations that determines the volume of run-off from impervious surfaces.

*Please refer to sheet C1.0 of the attached Exhibit 01.*

**Section 17.5.8 – Parking Regulations**

A.1. Parking spaces shall be provided on-site for development as set forth in Table 5-2:

Zoning Designation	Required Number of Parking Spaces
Condominium unit (Multi-family)	1.5 spaces per unit

*Please refer to sheet A1.04 of the attached Exhibit 01. Per Table 5-2, noted above, 1.5 spaces per unit are required. The proposed development provides a private single-car garage for each unit, as well as a driveway length for one (1) parking space in each driveway. A short-term pull-off parking space is also proposed on the high side of the proposed development, as highlighted on sheet A1.04 of the attached Exhibit 01.*

**Section 17.5.9 – Landscaping Regulations**

B. The foundation to landscaping design shall be based on fitting the desired building or development into the surrounding landscape in accordance with the building site design and grading and drainage design standards as sensitively as possible to preserve trees and natural vegetation while still achieving the envisioned land use pattern in the Comprehensive Plan and within the design parameters set forth by the CDC. New landscaping shall fill in the developed/graded area of a site as a transition from the building hardscape and the outside living areas to the natural environment while also complying with the Fire Mitigation and Forestry Management Regulations.

*Per the Design Review Process Application checklist item 9.E, a landscape plan is only required for final DRB review. Landscaping is intended to meet all Mountain Village CDC requirements, with a full landscaping plan provided at final DRB review.*

**Section 17.5.10 – Trash, Recycling, and General Storage Areas**

A. For all development, all trash containers shall be bear-proof, and trash and recycling containers shall be stored in an enclosure or garage as approved by the review authority. Locations and design for trash storage shall be indicated on the site plan. For multifamily or mixed-use developments, the minimal dimensions for trash and recycling enclosures shall be ten feet by twelve feet (10' x 12') if shared by more than four (4) units with a ceiling height of ten feet (10').

*Trash and recycling storage is anticipated to be located in each individual unit garage, as shown on A1.13. The proposed trash containers would be individual in nature to provide for easy removal, with an adequate number provided to match required building occupancy.*

### **Section 17.5.12 – Lighting Regulations**

B. The basic guideline for exterior lighting is for it to be subdued, understated, and indirect to minimize the negative impacts to surrounding lots and public rights-of-way.

*Per the Design Review Process Application checklist item 9.F, an outdoor lighting plan is only required for final DRB review. Outdoor lighting is intended to meet all Mountain Village CDC requirements, with a full lighting plan provided at final DRB review.*

### **Section 17.6.1.C – Steep Slopes**

If a developer proposed disturbance to slopes that are thirty percent (30%) or greater, the CDC required development application shall include a thorough, written evaluation of practicable alternatives to any fill, excavation, or disturbance of any slope's thirty percent (30%) or greater.

*Please refer to Exhibit 06.*

PROJECT LOCATION

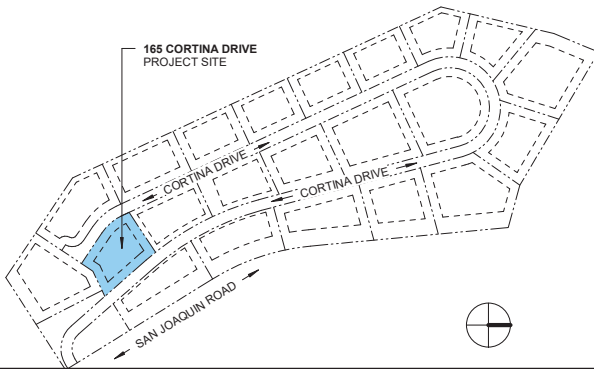

165 CORTINA DRIVE  
UNIT 17R  
MOUNTAIN VILLAGE, CO  
DRB PACKAGE  
DRB PRESENTATION

TOWN STAMP

359  
DESIGN

BRUCE D. WILKS  
B-2465  
8/20/2024



PROJECT TEAM

<p><b>ARCHITECTURE</b> 359 DESIGN CONTACT: WILL HENTSCHEL WHENTSCHEL@359DESIGN.CO</p>	<p><b>OWNER</b> BRENNER DESIGN GROUP CONTACT: MIKE BRENNER MIKE@BRENNERDG.COM</p>	<p><b>INTERIORS</b> HIGBY DESIGN CONTACT: EVA HIGBY EVA@HIGBYDESIGN.COM</p>
<p><b>CONTRACTOR</b> TOUGHER CONSTRUCTION CONTACT: RYAN TOUGHER RYAN@TOUGHERCONSTRUCTION.COM</p>	<p><b>CIVIL</b> GOFF ENGINEERING CONTACT: ROB HARRIES RHARRIES@GOFFENGINEERING.COM</p>	
<p><b>MECHANICAL &amp; PLUMBING</b> PROFICIENT ENGINEERING CONTACT: NATE FINNERTY NFINNERTY@PROFICIENTENGINEERING.COM</p>	<p><b>ELECTRICAL</b> PROFICIENT ENGINEERING CONTACT: JAMES JEAMBEY JJEAMBEY@PROFICIENTENGINEERING.COM</p>	
<p><b>STRUCTURAL</b> ZFA STRUCTURAL ENGINEERS CONTACT: EVAN GRAY EVANG@ZFA.COM</p>		
<p><b>MODULAR</b> PLANT PREFAB CONTACT: MATT LANGTON MATT@PLANTPREFAB.COM</p>	<p><b>MODULAR CONSULTANT</b> HELMERSON SIMS CONTACT: AMY SIMS AMY@HELMERSONSIMS.COM</p>	

DRAWING ABBREVIATIONS

AB ANCHOR BOLT	MEM MEMBRANE		
ACT ACUSTICAL TILE CEILING	MFR MANUFACTURER		
AFV ABOVE FINISH FLOOR	MIN MINIMUM		
ALUM ALUMINUM	MR MOISTURE RESISTANT		
AP ACCESS PANEL	MTL METAL		
APPRX APPROXIMATE	NIC NOT IN CONTRACT		
ARCH ARCHITECTURE	NO NUMBER		
ASSOC ASSOCIATED	NOM NOT TO SCALE		
BD BOARD	OA OVERALL		
BLDG BUILDING	OC ON CENTER		
BLK BLOCK	OH OVERHEAD		
BO BOTTOM OF	ORD OVERFLOW ROOF DRAIN		
BOT BOTTOM	OS OVERFLOW SCUPPER		
BRG BEARING	OPG OPENING		
BSMT BASEMENT	OROI OWNER PROVIDED OWNER		
CJ CONTROL JOINT	OPCI OWNER PROVIDED CONTRACTOR		
CL CENTERLINE			
CLG CEILING			
CLR CLEAR			
CMU CONCRETE MASONRY UNIT			
COL COLUMN			
CONC CONCRETE			
CONT CONTINUOUS			
COVR COVER			
CPT CARPET			
CT CERAMIC TILE			
CTR CENTER			
DEC DETENTION EQUIPMENT CONTRACTOR			
DET DETENTION			
DEMO DEMOLITION			
DIA DIAMETER			
DIM DIMENSION			
DF DRINKING FOUNTAIN			
DGB DETENTION GRAB BAR			
DR DOOR			
DWG DRAWING			
EA EACH			
EJ EXPANSION JOINT			
ELEC ELECTRICAL			
ELEV ELEVATOR			
EQ EQUAL			
EQUIP EQUIPMENT			
ER EPOXY RESIN			
EXT EXTERIOR			
FD FLOOR DRAIN			
FDN FOUNDATION			
FE FIRE EXTINGUISHER			
FF EL FINISH FLOOR ELEVATION			
FIN FINISH			
FRT FIRE RESISTANT TREATED			
FLR FLOOR			
FS FOOD SERVICE			
FT FOOT			
FTG FOOTING			
FUT FUTURE			
GA GAUGE			
GC GENERAL CONTRACTOR			
GL GLASS			
GR GRADE			
GYP BD GYPSUM BOARD			
HC HOLLOW CORE			
HT HEIGHT			
HM HOLLOW METAL			
HORIZ HORIZONTAL			
INT INTERIOR			
INSUL INSULATION			
JAN JANITOR			
JST JOIST			
LAV LAVATORY			
MAX MAXIMUM			
MECH MECHANICAL			

SYMBOLS

ROOM NAME XXXXX	ROOM NAME/NUMBER	CONCRETE/ PRECAST CONCRETE
X ---	EXISTING COLUMN CENTERLINE	SOIL
(X) ---	COLUMN CENTERLINE	SAND, EIFS FINISH COAT
(X)	ACCESSORY	BRICK
(1)	DEMOLITION NUMBERED NOTES	CMU
01 A0.XX	BUILDING WALL SECTION	STONE
A0.X X	ELEVATION	FIBERGLASS BATT INSULATION
01 A0.X X	SECTION DETAIL	XPS RIGID INSULATION
01 A0.X X	PLAN, BLOW-UP DETAIL	FOIL-FACED POLYISO RIGID INSULATION
(+9'-0")	CEILING HEIGHT	ccSPF - CLOSED CELL SPRAY POLYISO FOAM INSULATION
(A3)	PARTITION TYPE WITH NO SOUND ATTENUATION	GYPSUM BOARD OR FIBERGLASS-REINFORCED GYPSUM BOARD
(A3)	PARTITION TYPE WITH SOUND ATTENUATION	PLYWOOD
---	BUILDING EXPANSION JOINT	COVER BOARD

CEILING SYMBOLS

GYP BD CEILING	WALL MOUNTED FLUORESCENT FIXTURE
SUPPLY AIR	EXIT SIGNS - HATCH INDICATES EXIT TEXT AND ARROW INDICATES DIRECTION
RETURN AIR	SMOKE DETECTOR
EXHAUST AIR	SPEAKER
ACCESS PANEL	PROJECTOR
FLUORESCENT LIGHT	WALL WASHER
SUSPENDED LIGHT	PENDANT TYPE LIGHT FIXTURE
SUSPENDED FLUORESCENT LIGHT	WALL MOUNTED LIGHT FIXTURE
CHANDELIER	DOWNLIGHT
	STRIP LIGHT

GENERAL NOTES

- DO NOT SCALE DRAWINGS. LARGE SCALE DETAILS SHALL GOVERN OVER SMALL SCALE DETAILS. SPECIFICATIONS GOVERN ALL.
- CONTRACTOR TO ISSUE COMPLETE SET OF CONTRACT DOCUMENTS TO EACH SUBCONTRACTOR FOR COORDINATION OF WORK AND DESCRIPTION OF SCOPE.
- THERE SHALL BE NO SUBSTITUTION OF MATERIALS WHERE A MANUFACTURER IS SPECIFIED. WHERE THE TERM "OR EQUAL" IS USED THE ARCHITECT ALONE SHALL DETERMINE EQUALITY BASED ON INFORMATION SUBMITTED BY THE CONTRACTOR.
- REFER TO STRUCTURAL DRAWINGS FOR ALL REINFORCING.
- ARCHITECTURAL, MECHANICAL, ELECTRICAL, AND NON-STRUCTURAL SYSTEMS, COMPONENTS AND ELEMENTS PERMANENTLY ATTACHED TO STRUCTURES, INCLUDING SUPPORTING STRUCTURES AND ATTACHMENTS AND NON-BUILDING STRUCTURES THAT ARE SUPPORTED BY OTHER STRUCTURES, SHALL MEET THE REQUIREMENTS PER 2021 IBC CHAPTER 16 AND ASCE 7-02 SECTION 9.6 COORDINATE DESIGN WITH ARCHITECT AND ENGINEER OF RECORD.

INDEX OF DRAWINGS

Sheet List	
Sheet Number	Sheet Name
2 ARCHITECTURAL	
A0.00	COVER
A1.01	SITE PLAN
A1.02	SITE PLAN - LOT 17 CORTINA DRIVE
A1.04	SITE PLAN - PARKING
A1.11	LEVEL 01 PLAN
A1.12	LEVEL 02 PLAN
A1.13	LEVEL 03 PLAN
A1.14	LEVEL 04 PLAN
A1.15	ROOF PLAN
A1.16	AVERAGE BUILDING HEIGHT - ROOF PLAN
A1.21	UNIT A - DIM PLANS
A1.31	UNIT B - DIM PLANS
A1.41	UNIT C - DIM PLANS
A2.01	FRONT ELEVATION - MATERIALS
A2.02	FRONT ELEVATION - B&W
A2.03	BACK ELEVATION - MATERIALS
A2.04	BACK ELEVATION - B&W
A2.05	RIGHT ELEVATION - MATERIALS
A2.06	RIGHT ELEVATION - B&W
A2.07	LEFT ELEVATION - MATERIALS
A2.08	LEFT ELEVATION - B&W
A3.01	BUILDING SECTION
A3.02	BUILDING SECTION
A3.03	BUILDING SECTION
A5.01	WINDOW & DOOR SCHEDULE
A9.00	BUILDING HEIGHT REVIEW - EXISTING GRADING
A9.01	BUILDING HEIGHT REVIEW - PROPOSED GRADING
A9.10	SITE PHOTOS
A9.20	PERSPECTIVE VIEWS
A9.21	PERSPECTIVE VIEWS
3 CIVIL	
C0.01	SURVEY
C01.0	CIVIL SITE PLAN

PROJECT DESCRIPTION

	PROVIDED	ALLOWABLE
LOT SIZE:	0.200 Acres (8,721 Square Feet)	
LOT COVERAGE:	4,473 SF (51%)	5,668 SF (65%)
ZONING DESIGNATION:	MULTIFAMILY	
MAX. BUILDING HEIGHT:	52' - 10"	53' - 0"
MAX. AVERAGE HEIGHT:	40' - 7"	53' - 0"
UNITS PROVIDED:	3 UNITS	
PARKING PROVIDED:	6 PARKING SPACES (1 GARAGE + 1 DRIVEWAY SPACE PER UNIT)	

LOT 165 CORTINA DRIVE  
Mountain Village, CO

No.	Description	Date

PROJECT NUMBER: 24192  
DATE: 10/28/2024

TITLE: DRB PACKAGE

SHEET TITLE: COVER

SHEET NO: A0.00



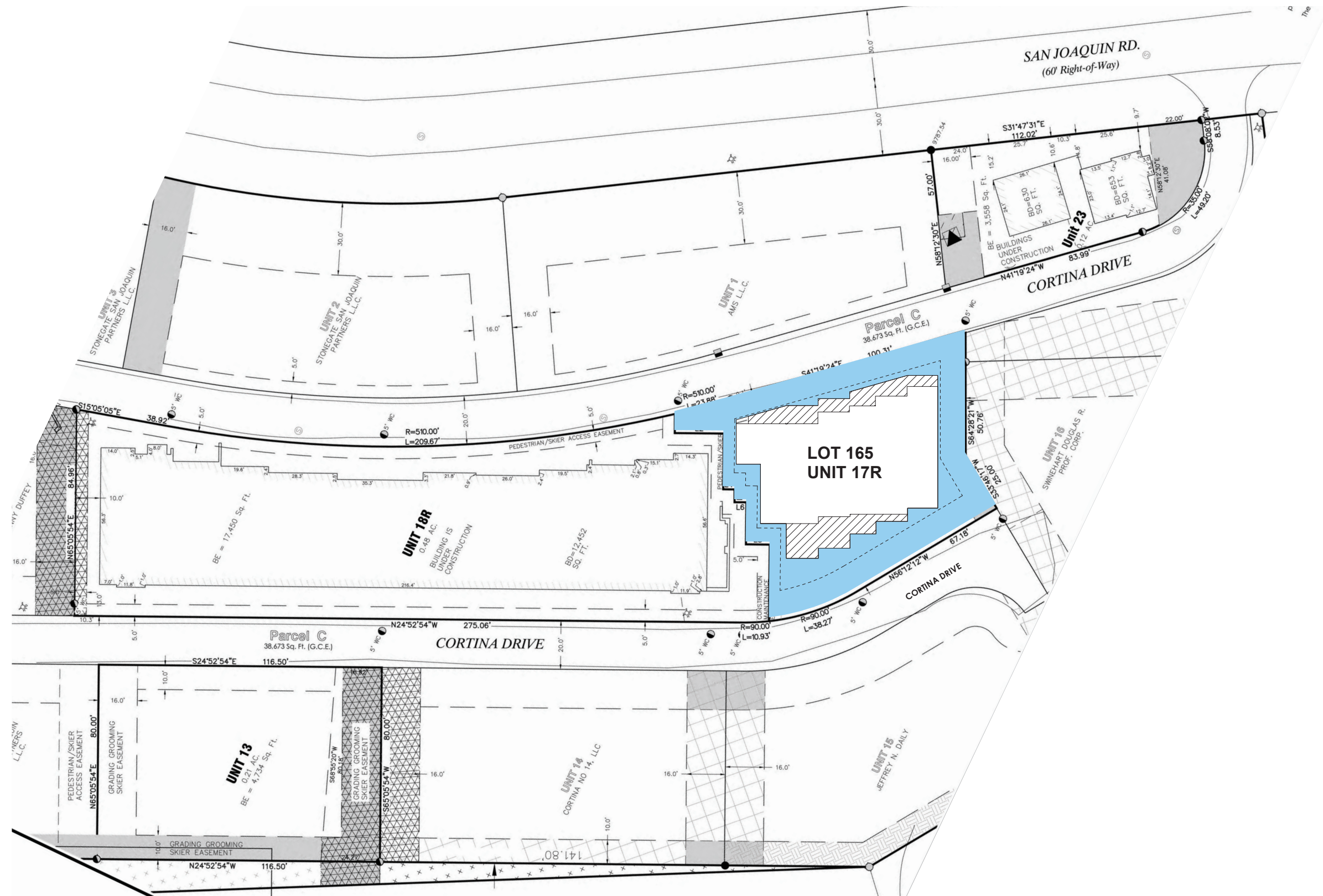

**1 SITE PLAN OVERALL**  
1" = 20'-0"



**359**  
DESIGN



**LOT 165 CORTINA DRIVE**

Mountain Village, CO

No.	Description	Date

PROJECT NUMBER: 24102  
SCALE DATE: 10/28/2024

DRB PACKAGE

SHEET TITLE: **SITE PLAN**

SHEET NO.

**A1.01**

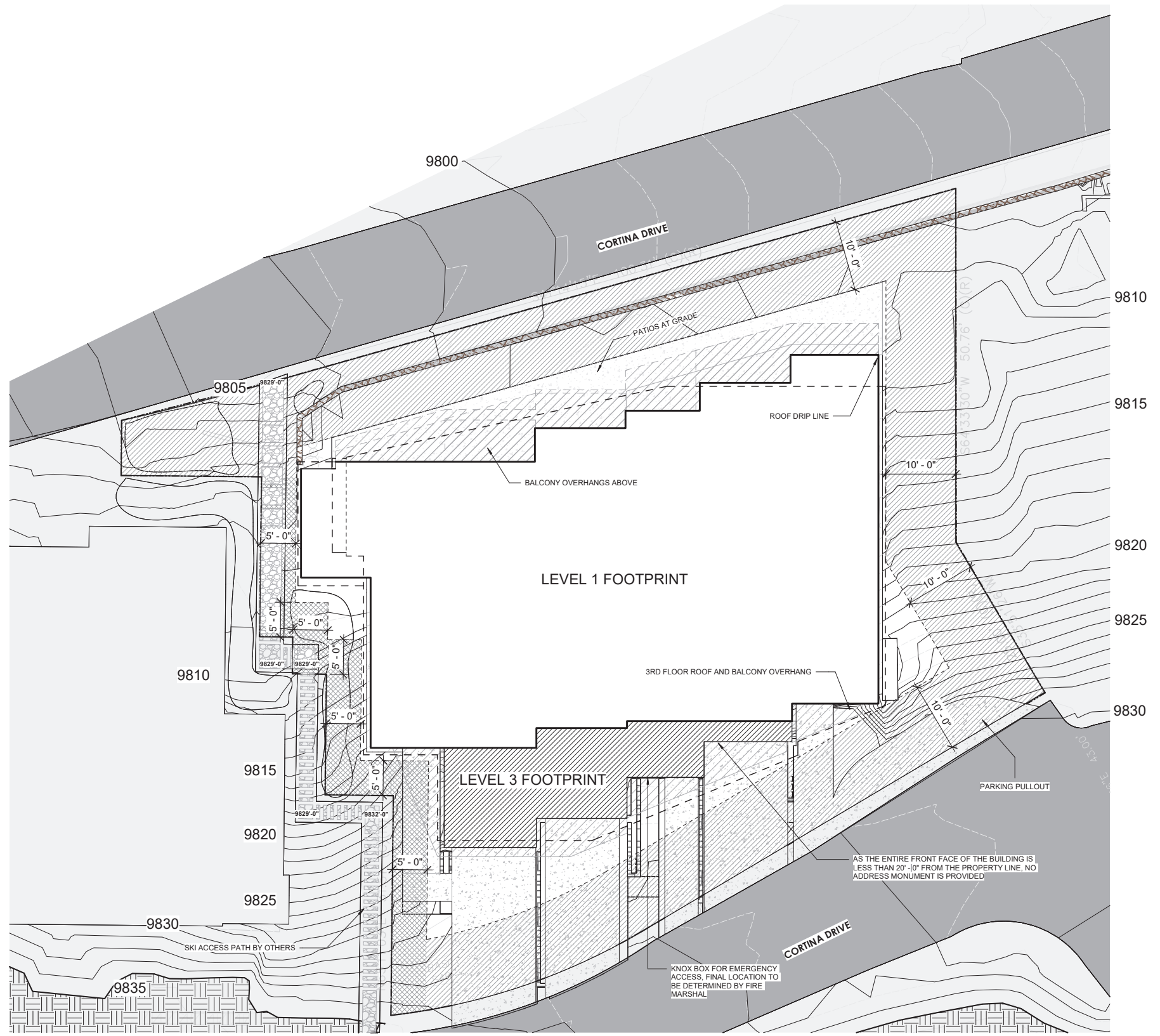

### SITE PLAN LEGEND

	BUILDING OVERHANGS
	BUILDING FOOTPRINT
	CONSTRUCTION MAINTENANCE EASEMENT
	UTILITY & GRADING GROOMING SKIER ACCESS EASEMENT
	PROPERTY LINE
	SETBACK LINE
	MAJOR PROPOSED TOPOGRAPHY LINES
	MINOR PROPOSED TOPOGRAPHY LINES
	EXISTING TOPOGRAPHY LINES

359  
DESIGN



**LOT 165 CORTINA DRIVE**  
Mountain Village, CO

No.	Description	Date

PROJECT NUMBER: 24102  
SCALE DATE: 10/28/2024

DRB PACKAGE

SHEET TITLE:  
**SITE PLAN - LOT 17  
CORTINA DRIVE**

SHEET NO:  
**A1.02**

**1 SITE PLAN - LOT 17 CORTINA DRIVE**  
1/8" = 1'-0"



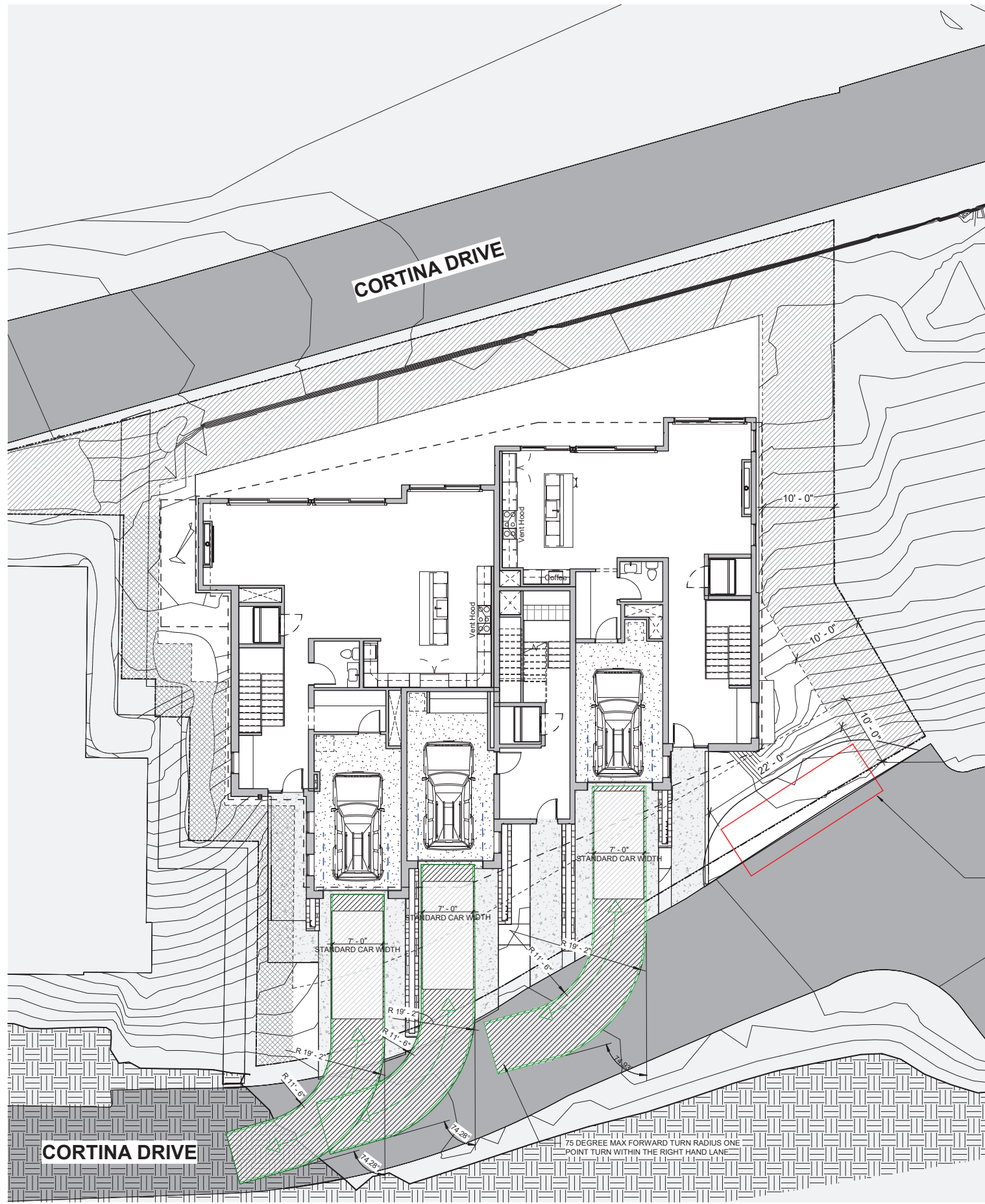

NOTE: THE SUMMIT HOA WILL REQUIRE RESIDENTS TO BACK INTO UNIT GARAGES

PARKING PULLOUT  
 SIZED TO MATCH A STANDARD DELIVERY TRUCK

**1 SITE PLAN - PARKING**  
 1/8" = 1'-0"



359  
 DESIGN

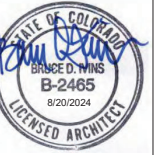

LOT 165 CORTINA DRIVE  
 Mountain Village, CO

No.	Description	Date

PROJECT NUMBER: 24102  
 DATE: 10/28/2024

DRB PACKAGE

SITE PLAN - PARKING

A1.04

GSF SCHEDULE - LEVEL 01	
Name	Area
UNIT A LEVEL 1	1590 SF
UNIT B LEVEL 1	1730 SF

NSF SCHEDULE	
Name	Area
A - BATH 3	72 SF
A - BATH 4	72 SF
A - BED 3	159 SF
A - BED 4 DECK	114 SF
A - BUNKBED 4	183 SF
A - BUNKBED DECK	104 SF
A - DEN DECK	84 SF
A - DEN/ BED 5	169 SF
A - ELEVATOR	31 SF
A - MEDIA	175 SF
A - POOL TABLE	219 SF
A - POWDER	28 SF
B - BATH 2	84 SF
B - BATH 4	77 SF
B - BATH 5	63 SF
B - BED 2	118 SF
B - BED 2 DECK	94 SF
B - BED 4 DECK	106 SF
B - BED 5/DEN	135 SF
B - BUNKBED 4	183 SF
B - DEN DECK	104 SF
B - ELEVATOR	31 SF
B - MEDIA	186 SF
B - POWDER	28 SF
B - POOL TABLE	246 SF
WATER ENTRY	78 SF

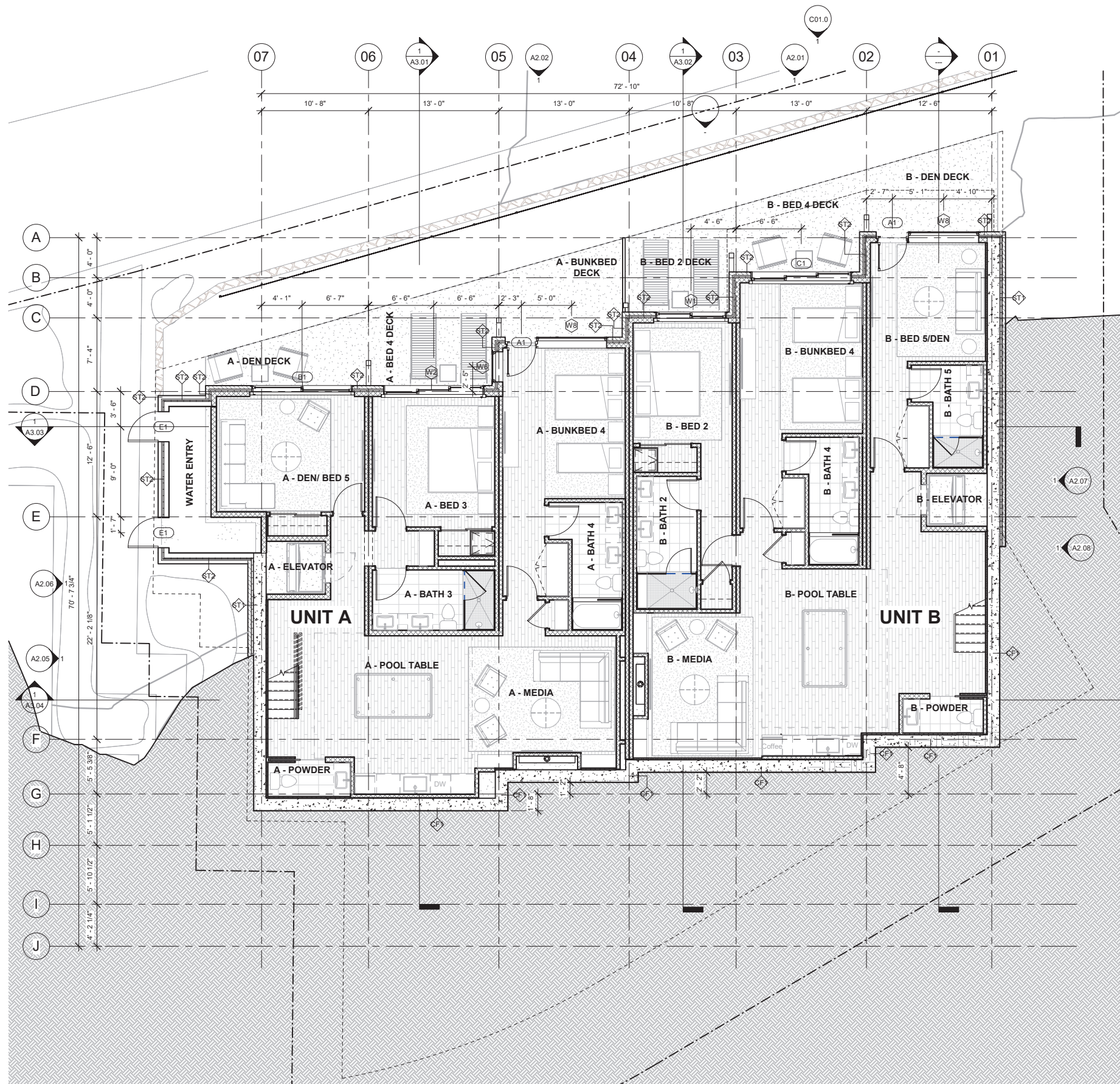

**NOTE:**  
 GRAY HATCH INDICATES SYSTEMS BUILT SCOPE, TYP.  
 CROSSHATCH INDICATES PANELIZED SCOPE, TYP.

- FLOOR PLAN GENERAL NOTES:**
- ALL DIMENSIONS ARE TAKEN FROM FACE OF STUD, U.N.O.
  - ALL GRIDLINES ALIGN WITH FACE OF STUD OR FACE OF STRUCTURE U.N.O. GRIDLINES DO NOT MATCH GRIDLINES FOR FOUNDATION PERMIT DRAWINGS
  - KEYNOTES ARE SPECIFIC TO EACH DRAWING SHEET
  - ALL INTERIOR WALL PARTITION TYPES ARE "TYPE A1" WHICH INCLUDE SOUND BATT INSULATION, U.N.O.
  - ALL CLOSETS TO INCLUDE SHELF & ROD RE: INTERIOR DRAWINGS
  - FURNITURE IS SHOWN FOR REFERENCE ONLY
  - REFER TO THE A1 SERIES FOR UNIT PLANS, WHICH INCLUDE FLOOR PLAN, REFLECTED CEILING PLAN AND FINISH PLANS FOR EACH UNIT AND LEVEL
  - REFER TO THE A2 SERIES FOR EXTERIOR ELEVATIONS AND FOR DESIGNATIONS OF EXTERIOR MATERIALS
  - REFER TO THE A3 SERIES FOR ALL BUILDING AND WALL SECTIONS
  - REFER TO THE A5 AND A6 SERIES FOR DOOR AND WINDOW INFORMATION, SCHEDULES AND DETAILS
  - REFER TO INTERIORS DRAWINGS FOR FINISH INFORMATION AND SCHEDULES
  - ENSURE A HARDWIRED WITH BATTERY BACKUP SMOKE DETECTOR AND CARBON MONOXIDE DETECTOR IS INSTALLED ON EACH LEVEL IN A CENTRALLY LOCATED COMMON AREA PER IRC R314.6 AND NFPA 720 AND BE INTERCONNECTED PER IRC R314.4. SMOKE ALARMS SHALL BE PLACED NOT LESS THAN 3' FROM A BATHROOM DOOR WHEN THE BATHROOM CONTAINS A TUB OR SHOWER
  - FLOOR LEVELING MAY BE REQUIRED FOR TILE AND WOOD INSTALLATIONS THAT OCCUR AT SLAB ON GRADE CONDITIONS
  - ALL EXPOSED CONCRETE FOUNDATION WALLS, CRAWLSPACES, AND FLOORS EXPOSED TO THE EXTERIOR ARE REQUIRED TO BE INSULATED PER THE 2021 IECC
  - ALL CEILINGS TO BE GYPSUM WALL BOARD U.N.O.
  - COORDINATE LOCATIONS FOR ACCESS DOORS WITH ALL FINAL MECHANICAL EQUIPMENT
  - GUARDRAILS ARE REQUIRED AT ALL LOCATIONS WHERE THERE IS A GRADE CHANGE OF 30" OR MORE
  - RE: ROOF DETAILS & DEMISING WALL DETAILS FOR TYPICAL DRAFT STOPPING/FIRE BLOCKING AT VERTICAL CHASES AT INTERMEDIATE FLOORS AND ROOF/CEILING INTERSECTIONS, AND FOR TYPICAL DRAFT STOPPING/FIRE BLOCKING AT SOFFITS. LUMINAIRES IN WET OR DAMP LOCATIONS TO RATED FOR THESE LOCATIONS PER NEC 410.10.
  - CARBON MONOXIDE ALARMS SHALL REVEIVE BATTERY PRIMARY POWER FROM THE BUILDING WIRING WITH BATTERY BACKUP AND ALL ALARMS WITHIN A DWELLING SHALL BE INTERCONNECTED PER NFPA 720.
  - SLOPE GRADE AWAY FROM BUILDING 6" WITHIN THE FIRST 10' PER IRC R401.3. SLOPE EXTERIOR LANDINGS AND OTHER IMPERVIOUS SURFACES 2% PER IRC R311.3.
  - LAP SIDING: PLANK BUTT JOINTS SHOULD BE TIGHT AND OCCUR ONLY AT STUDS OVER A 6" WIDE PIECE OF FLASHING LAPPED 1" OVER THE PLANK BELOW. FLASHING SHOULD BE OF A DURABLE WATERPROOF MATERIAL SUCH AS WINDOW FLASHING OR POLYOLEFIN WRB.
  - ENSURE A WATER-RESISTIVE VAPOR-PERMEABLE BARRIER WITH A PERFORMANCE AT LEAST EQUIVALENT TO TWO LAYERS OF GRADE D PAPER IS PROVIDED PER IRC R703.7.3. AS UNDERLAYMENT FOR STUCCO. POLYMER-BASED WRB'S ARE EQUIVALENT TO GRADE D PAPER.
  - WATER RESISTIVE BARRIER AT WALLS SHALL LAP A MIN. OF 2" HORIZONTALLY AND 6" VERTICALLY PER IRC R703.2. POLYMER BASED WRB'S SHALL LAP 6" MIN. HORIZONTALLY AND VERTICALLY.
  - CONFER WITH AUTHORITY HAVING JURISDICTION TO DETERMINE IF RADON CONTROL METHODS ARE REQUIRED BY LOCAL ORDINANCE FOR NEW RESIDENTIAL CONSTRUCTION. REFER TO IRC APPENDIX F.
  - ON WOOD FLOOR CONSTRUCTION, FILL VOIDS AT THE UNDERSIDE OF TUBS AND SHOWER PANS WITH INSULATION FOR ACOUSTIC DAMPENING.
  - PROVIDE GLASS MAT GYP BD BACKING, FIBER-REINFORCED GYP BD, FIBER-CEMENT BOARD OR FIBER MAT REINFORCED CEMENT BOARD BACKER PANELS AT TUB AND SHOWER AREAS.
  - RECESSED LUMINAIRES INSTALLED IN THE BUILDING THERMAL ENVELOPE SHALL BE IC-RATED FOR ZERO CLEARANCE INSULATION CONTACT AND SEALED AIR TIGHT.
  - PROVIDE CLASS V VAPOR BARRIER OVER GRADE IN CRAWL SPACE. LAP UP FOUNDATION WALL MINIMUM 6" AND TAPE AND SEAM.

**1 LEVEL 01 OVERALL**  
 3/16" = 1'-0"

359  
 DESIGN

BRUCE D. WINS  
 B-2465  
 8/20/2024  
 LICENSED ARCHITECT

**LOT 165 CORTINA DRIVE**  
 Mountain Village, CO

No.	Description	Date

PROJECT NUMBER: 24102  
 SHEET DATE: 10/20/2024

DRB PACKAGE

SHEET TITLE: LEVEL 01 PLAN

SHEET NO: A1.11

GSF SCHEDULE - LEVEL 02	
Name	Area
UNIT A LEVEL 2	1590 SF
UNIT B LEVEL 2	1678 SF

NSF SCHEDULE	
Name	Area
A - BATH 2	115 SF
A - BED 2	169 SF
A - BEDROOM DECK	177 SF
A - ELEVATOR	31 SF
A - FLEX	129 SF
A - LAUNDRY	73 SF
A - MECH	64 SF
A - PRIMARY BATH	174 SF
A - PRIMARY BED	226 SF
A - WALK-IN	50 SF
B - BATH 3	63 SF
B - BATH 6	59 SF
B - BED 3	137 SF
B - BED 6	156 SF
B - BEDROOM DECK	170 SF
B - ELEVATOR	31 SF
B - LAUNDRY	81 SF
B - MECH	45 SF
B - PRIMARY BATH	185 SF
B - PRIMARY BED	228 SF
B - WALK-IN	75 SF

**NOTE:**  
 GRAY HATCH INDICATES SYSTEMS BUILT SCOPE, TYP.  
 CROSSHATCH INDICATES PANELIZED SCOPE, TYP.

- FLOOR PLAN GENERAL NOTES:**
- ALL DIMENSIONS ARE TAKEN FROM FACE OF STUD, U.N.O.
  - ALL GRIDLINES ALIGN WITH FACE OF STUD OR FACE OF STRUCTURE U.N.O. GRIDLINES DO NOT MATCH GRIDLINES FOR FOUNDATION PERMIT DRAWINGS
  - KEYNOTES ARE SPECIFIC TO EACH DRAWING SHEET
  - ALL INTERIOR WALL PARTITION TYPES ARE "TYPE A1" WHICH INCLUDE SOUND BATT INSULATION, U.N.O.
  - ALL CLOSETS TO INCLUDE SHELF & ROD RE: INTERIOR DRAWINGS
  - FURNITURE IS SHOWN FOR REFERENCE ONLY
  - REFER TO THE A1 SERIES FOR UNIT PLANS, WHICH INCLUDE FLOOR PLAN, REFLECTED CEILING PLAN AND FINISH PLANS FOR EACH UNIT AND LEVEL
  - REFER TO THE A2 SERIES FOR EXTERIOR ELEVATIONS AND FOR DESIGNATIONS OF EXTERIOR MATERIALS.
  - REFER TO THE A3 SERIES FOR ALL BUILDING AND WALL SECTIONS
  - REFER TO THE A5 AND A6 SERIES FOR DOOR AND WINDOW INFORMATION, SCHEDULES AND DETAILS
  - REFER TO INTERIORS DRAWINGS FOR FINISH INFORMATION AND SCHEDULES
  - ENSURE A HARDWIRED WITH BATTERY BACKUP SMOKE DETECTOR AND CARBON MONOXIDE DETECTOR IS INSTALLED ON EACH LEVEL IN A CENTRALLY LOCATED COMMON AREA PER IRC R314.6 AND NFPA 720 AND BE INTERCONNECTED PER IRC R314.4. SMOKE ALARMS SHALL BE PLACED NOT LESS THAN 3' FROM A BATHROOM DOOR WHEN THE BATHROOM CONTAINS A TUB OR SHOWER.
  - FLOOR LEVELING MAY BE REQUIRED FOR TILE AND WOOD INSTALLATIONS THAT OCCUR AT SLAB ON GRADE CONDITIONS
  - ALL EXPOSED CONCRETE FOUNDATION WALLS, CRAWLSPACES, AND FLOORS EXPOSED TO THE EXTERIOR ARE REQUIRED TO BE INSULATED PER THE 2021 IECC
  - ALL CEILINGS TO BE GYPSUM WALL BOARD U.N.O.
  - COORDINATE LOCATIONS FOR ACCESS DOORS WITH ALL FINAL MECHANICAL EQUIPMENT
  - GUARDRAILS ARE REQUIRED AT ALL LOCATIONS WHERE THERE IS A GRADE CHANGE OF 30" OR MORE
  - RE: ROOF DETAILS & DEMISING WALL DETAILS FOR TYPICAL DRAFT STOPPING/FIRE BLOCKING AT VERTICAL CHASES AT INTERMEDIATE FLOORS AND ROOF/CEILING INTERSECTIONS, AND FOR TYPICAL DRAFT STOPPING/FIRE BLOCKING AT SOFFITS. LUMINAIRES IN WET OR DAMP LOCATIONS TO RATED FOR THESE LOCATIONS PER NEC 410.10.
  - CARBON MONOXIDE ALARMS SHALL RECEIVE BATTERY PRIMARY POWER FROM THE BUILDING WIRING WITH BATTERY BACKUP AND ALL ALARMS WITHIN A DWELLING SHALL BE INTERCONNECTED PER NFPA 720.
  - SLOPE GRADE AWAY FROM BUILDING 6" WITHIN THE FIRST 10' PER IRC R401.3. SLOPE EXTERIOR LANDINGS AND OTHER IMPERVIOUS SURFACES 2% PER IRC R511.3.
  - LAP SIDING: PLANK BUTT JOINTS SHOULD BE TIGHT AND OCCUR ONLY AT STUDS OVER A 6" WIDE PIECE OF FLASHING LAPPED 1" OVER THE PLANK BELOW. FLASHING SHOULD BE OF A DURABLE WATERPROOF MATERIAL SUCH AS WINDOW FLASHING OR POLYOLEFIN WRB.
  - ENSURE A WATER-RESISTIVE VAPOR-PERMEABLE BARRIER WITH A PERFORMANCE AT LEAST EQUIVALENT TO TWO LAYERS OF GRADE D PAPER IS PROVIDED PER IRC R703.7.3. AS UNDERLAYMENT FOR STUCCO. POLYMER-BASED WRB'S ARE EQUIVALENT TO GRADE D PAPER.
  - WATER RESISTIVE BARRIER AT WALLS SHALL LAP A MIN. OF 2" HORIZONTALLY AND 6" VERTICALLY PER IRC R703.2. POLYMER BASED WRB'S SHALL LAP 6" MIN. HORIZONTALLY AND VERTICALLY.
  - CONFER WITH AUTHORITY HAVING JURISDICTION TO DETERMINE IF RADON CONTROL METHODS ARE REQUIRED BY LOCAL ORDINANCE FOR NEW RESIDENTIAL CONSTRUCTION. REFER TO IRC APPENDIX F.
  - ON WOOD FLOOR CONSTRUCTION, FILL VOIDS AT THE UNDERSIDE OF TUBS AND SHOWER PANS WITH INSULATION FOR ACOUSTIC DAMPENING.
  - PROVIDE GLASS MAT GYP BD, FIBER-CEMENT BOARD OR FIBER MAT REINFORCED CEMENT BOARD BACKER PANELS AT TUB AND SHOWER AREAS.
  - RECESSED LUMINAIRES INSTALLED IN THE BUILDING THERMAL ENVELOPE SHALL BE IC-RATED FOR ZERO CLEARANCE INSULATION CONTACT AND SEALED AIR TIGHT.
  - PROVIDE CLASS I VAPOR BARRIER OVER GRADE IN CRAWL SPACE. LAP UP FOUNDATION WALL MINIMUM 6" AND TAPE AND SEAM.

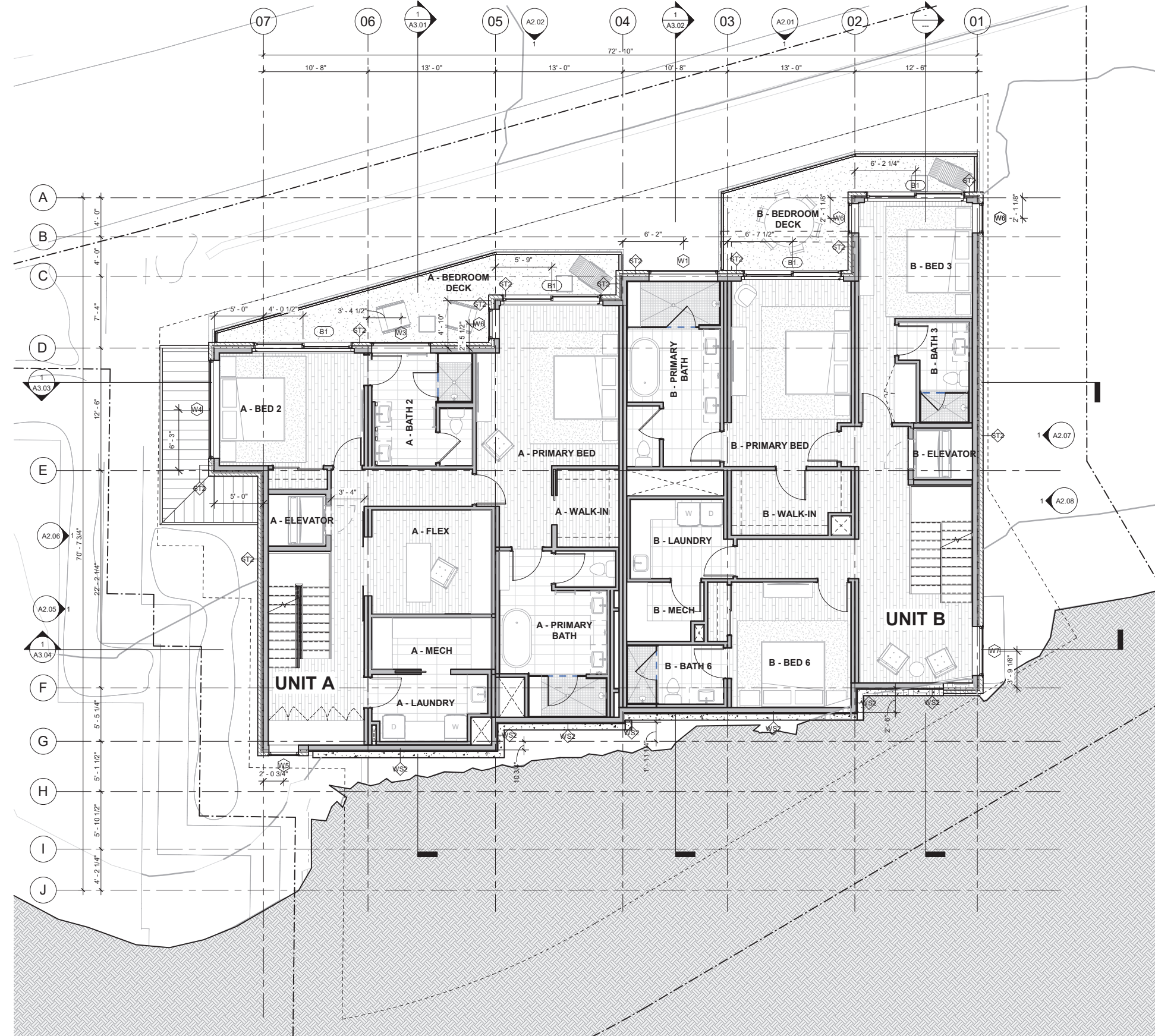

**1 LEVEL 02 OVERALL**  
 3/16" = 1'-0"

**359 DESIGN**



**LOT 165 CORTINA DRIVE**  
 Mountain Village, CO

No.	Description	Date

PROJECT NUMBER: 24102  
 SCALE DATE: 10/28/2024

**DRB PACKAGE**

**LEVEL 02 PLAN**

**A1.12**

GSF SCHEDULE - LEVEL 03	
Name	Area
UNIT A LEVEL 3	1585 SF
UNIT B LEVEL 3	1400 SF
UNIT C LEVEL 3	677 SF

NSF SCHEDULE	
Name	Area
A - DINING	134 SF
A - ELEVATOR	31 SF
A - ENTRY	71 SF
A - FAMILY ROOM	229 SF
A - GARAGE	261 SF
A - KITCHEN	264 SF
A - LIVING	142 SF
A - LIVING ROOM DECK	257 SF
A - MUDROOM	58 SF
A - POWDER	41 SF
B - DINING	126 SF
B - ELEVATOR	31 SF
B - ENTRY	50 SF
B - GARAGE	249 SF
B - KITCHEN	209 SF
B - LIVING	257 SF
B - LIVING ROOM DECK	309 SF
B - MUDROOM	57 SF
B - POWDER	34 SF
C - ELEVATOR	31 SF
C - ENTRY	98 SF
C - GARAGE	281 SF
C - MUDROOM	125 SF

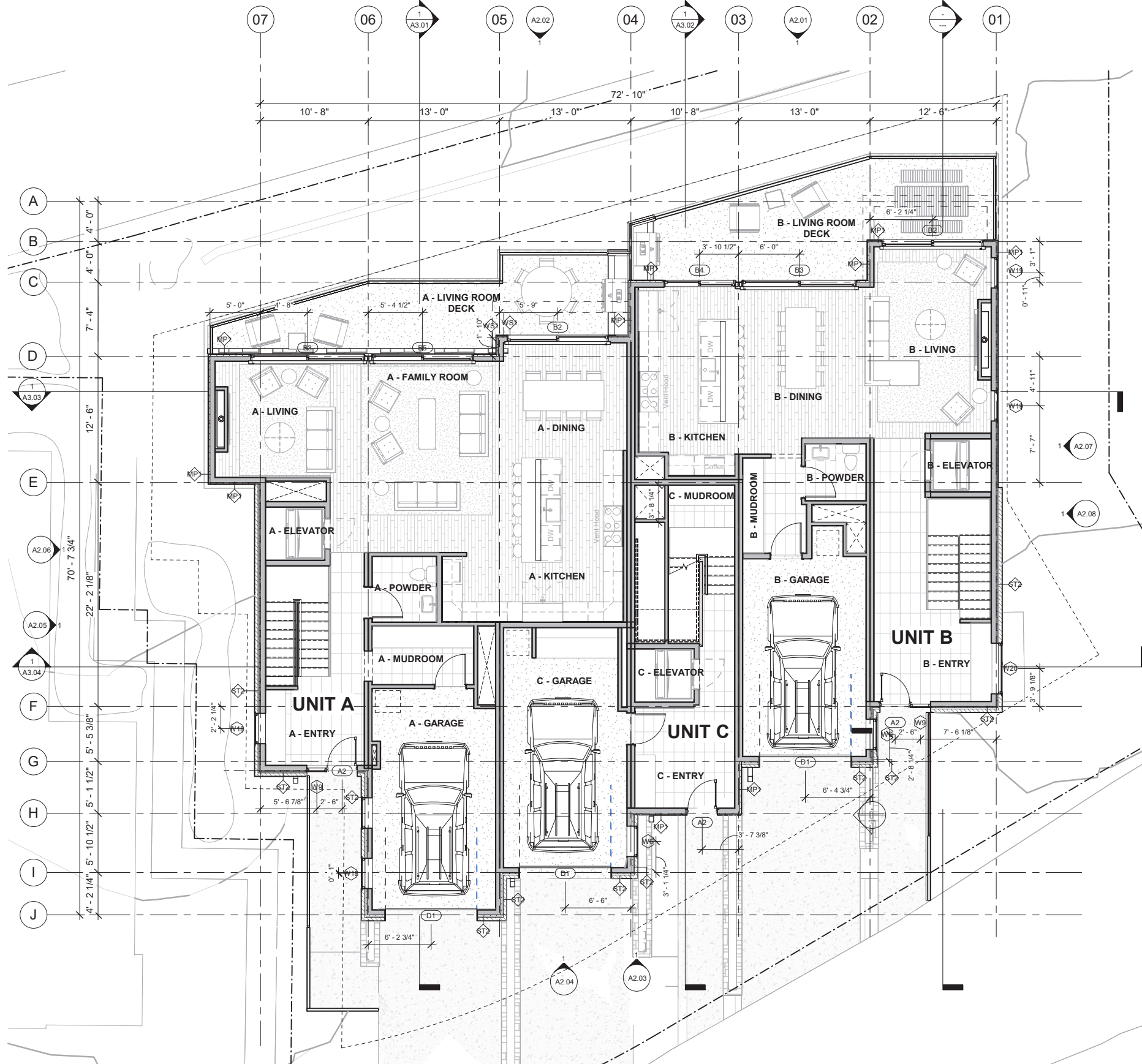

**NOTE:**  
 GRAY HATCH INDICATES SYSTEMS BUILT SCOPE, TYP.  
 CROSSHATCH INDICATES PANELIZED SCOPE, TYP.

- FLOOR PLAN GENERAL NOTES:**
- ALL DIMENSIONS ARE TAKEN FROM FACE OF STUD, U.N.O.
  - ALL GRIDLINES ALIGN WITH FACE OF STUD OR FACE OF STRUCTURE U.N.O. GRIDLINES DO NOT MATCH GRIDLINES FOR FOUNDATION PERMIT DRAWINGS
  - KEYNOTES ARE SPECIFIC TO EACH DRAWING SHEET
  - ALL INTERIOR WALL PARTITION TYPES ARE "TYPE A1" WHICH INCLUDE SOUND BATT INSULATION, U.N.O.
  - ALL CLOSETS TO INCLUDE SHELF & ROD RE: INTERIOR DRAWINGS
  - FURNITURE IS SHOWN FOR REFERENCE ONLY
  - REFER TO THE A1 SERIES FOR UNIT PLANS, WHICH INCLUDE FLOOR PLAN, REFLECTED CEILING PLAN AND FINISH PLANS FOR EACH UNIT AND LEVEL
  - REFER TO THE A2 SERIES FOR EXTERIOR ELEVATIONS AND FOR DESIGNATIONS OF EXTERIOR MATERIALS.
  - REFER TO THE A3 SERIES FOR ALL BUILDING AND WALL SECTIONS
  - REFER TO THE A5 AND A6 SERIES FOR DOOR AND WINDOW INFORMATION, SCHEDULES AND DETAILS
  - REFER TO INTERIORS DRAWINGS FOR FINISH INFORMATION AND SCHEDULES
  - ENSURE A HARDWIRED WITH BATTERY BACKUP SMOKE DETECTOR AND CARBON MONOXIDE DETECTOR IS INSTALLED ON EACH LEVEL IN A CENTRALLY LOCATED COMMON AREA PER IRC R314.6 AND NFPA 720 AND BE INTERCONNECTED PER IRC R314.4. SMOKE ALARMS SHALL BE PLACED NOT LESS THAN 3' FROM A BATHROOM DOOR WHEN THE BATHROOM CONTAINS A TUB OR SHOWER.
  - FLOOR LEVELING MAY BE REQUIRED FOR TILE AND WOOD INSTALLATIONS THAT OCCUR AT SLAB ON GRADE CONDITIONS
  - ALL EXPOSED CONCRETE FOUNDATION WALLS, CRAWLSPACES, AND FLOORS EXPOSED TO THE EXTERIOR ARE REQUIRED TO BE INSULATED PER THE 2021 IECC
  - ALL CEILINGS TO BE GYPSUM WALL BOARD U.N.O.
  - COORDINATE LOCATIONS FOR ACCESS DOORS WITH ALL FINAL MECHANICAL EQUIPMENT
  - GUARDRAILS ARE REQUIRED AT ALL LOCATIONS WHERE THERE IS A GRADE CHANGE OF 30" OR MORE
  - RE: ROOF DETAILS & DEMISING WALL DETAILS FOR TYPICAL DRAFT STOPPING/FIRE BLOCKING AT VERTICAL CHASES AT INTERMEDIATE FLOORS AND ROOF/CEILING INTERSECTIONS, AND FOR TYPICAL DRAFT STOPPING/FIRE BLOCKING AT SOFFITS. LUMINAIRES IN WET OR DAMP LOCATIONS TO RATED FOR THESE LOCATIONS PER NEC 410.10.
  - CARBON MONOXIDE ALARMS SHALL RECEIVE BATTERY PRIMARY POWER FROM THE BUILDING WIRING WITH BATTERY BACKUP AND ALL ALARMS WITHIN A DWELLING SHALL BE INTERCONNECTED PER NFPA 720.
  - SLOPE GRADE AWAY FROM BUILDING 6" WITHIN THE FIRST 10' PER IRC R401.3. SLOPE EXTERIOR LANDINGS AND OTHER IMPERVIOUS SURFACES 2% PER IRC R511.3.
  - LAP SIDING: PLANK BUTT JOINTS SHOULD BE TIGHT AND OCCUR ONLY AT STUDS OVER A 6" WIDE PIECE OF FLASHING LAPPED 1" OVER THE PLANK BELOW. FLASHING SHOULD BE OF A DURABLE WATERPROOF MATERIAL SUCH AS WINDOW FLASHING OR POLYOLEFIN WRB.
  - ENSURE A WATER-RESISTIVE VAPOR-PERMEABLE BARRIER WITH A PERFORMANCE AT LEAST EQUIVALENT TO TWO LAYERS OF GRADE D PAPER IS PROVIDED PER IRC R703.7.3. AS UNDERLAYMENT FOR STUCCO. POLYMER-BASED WRB'S ARE EQUIVALENT TO GRADE D PAPER.
  - WATER RESISTIVE BARRIER AT WALLS SHALL LAP A MIN. OF 2" HORIZONTALLY AND 6" VERTICALLY PER IRC R703.2. POLYMER BASED WRB'S SHALL LAP 6" MIN. HORIZONTALLY AND VERTICALLY.
  - CONFER WITH AUTHORITY HAVING JURISDICTION TO DETERMINE IF RADON CONTROL METHODS ARE REQUIRED BY LOCAL ORDINANCE FOR NEW RESIDENTIAL CONSTRUCTION. REFER TO IRC APPENDIX F.
  - ON WOOD FLOOR CONSTRUCTION, FILL VOIDS AT THE UNDERSIDE OF TUBS AND SHOWER PANS WITH INSULATION FOR ACOUSTIC DAMPENING.
  - PROVIDE GLASS MAT GYP BD BACKING, FIBER-REINFORCED GYP BD, FIBER-CEMENT BOARD OR FIBER MAT REINFORCED CEMENT BOARD BACKER PANELS AT TUB AND SHOWER AREAS.
  - RECESSED LUMINAIRES INSTALLED IN THE BUILDING THERMAL ENVELOPE SHALL BE IC-RATED FOR ZERO CLEARANCE INSULATION CONTACT AND SEALED AIR TIGHT.
  - PROVIDE CLASS I VAPOR BARRIER OVER GRADE IN CRAWL SPACE. LAP UP FOUNDATION WALL MINIMUM 6" AND TAPE AND SEAM.

**1 LEVEL 03 OVERALL**  
 3/16" = 1'-0"

**359 DESIGN**

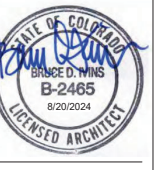

**LOT 165 CORTINA DRIVE**  
 Mountain Village, CO

No.	Description	Date

PROJECT NUMBER: 24102  
 SCALE DATE: 10/28/2024

DRB PACKAGE

LEVEL 03 PLAN

**A1.13**

GSF SCHEDULE - LEVEL 04	
Name	Area
UNIT C LEVEL 4	3470 SF

NSF SCHEDULE	
Name	Area
C - BATH 2	60 SF
C - BATH 3	59 SF
C - BATH 4	84 SF
C - BED 2	178 SF
C - BED 3	191 SF
C - BED 5	133 SF
C - BEDROOM DECK	117 SF
C - BEDROOM DECK	126 SF
C - BUNKBED 4	139 SF
C - DINING	146 SF
C - ELEVATOR	31 SF
C - KITCHEN	299 SF
C - LAUNDRY	46 SF
C - LIVING	233 SF
C - LIVING ROOM DECK	299 SF
C - MECH	28 SF
C - MEDIA	213 SF
C - POWDER	26 SF
C - PRIMARY BATH	153 SF
C - PRIMARY BED	290 SF
C - STORAGE	23 SF
C - WALK-IN	99 SF
C - POOL TABLE	184 SF

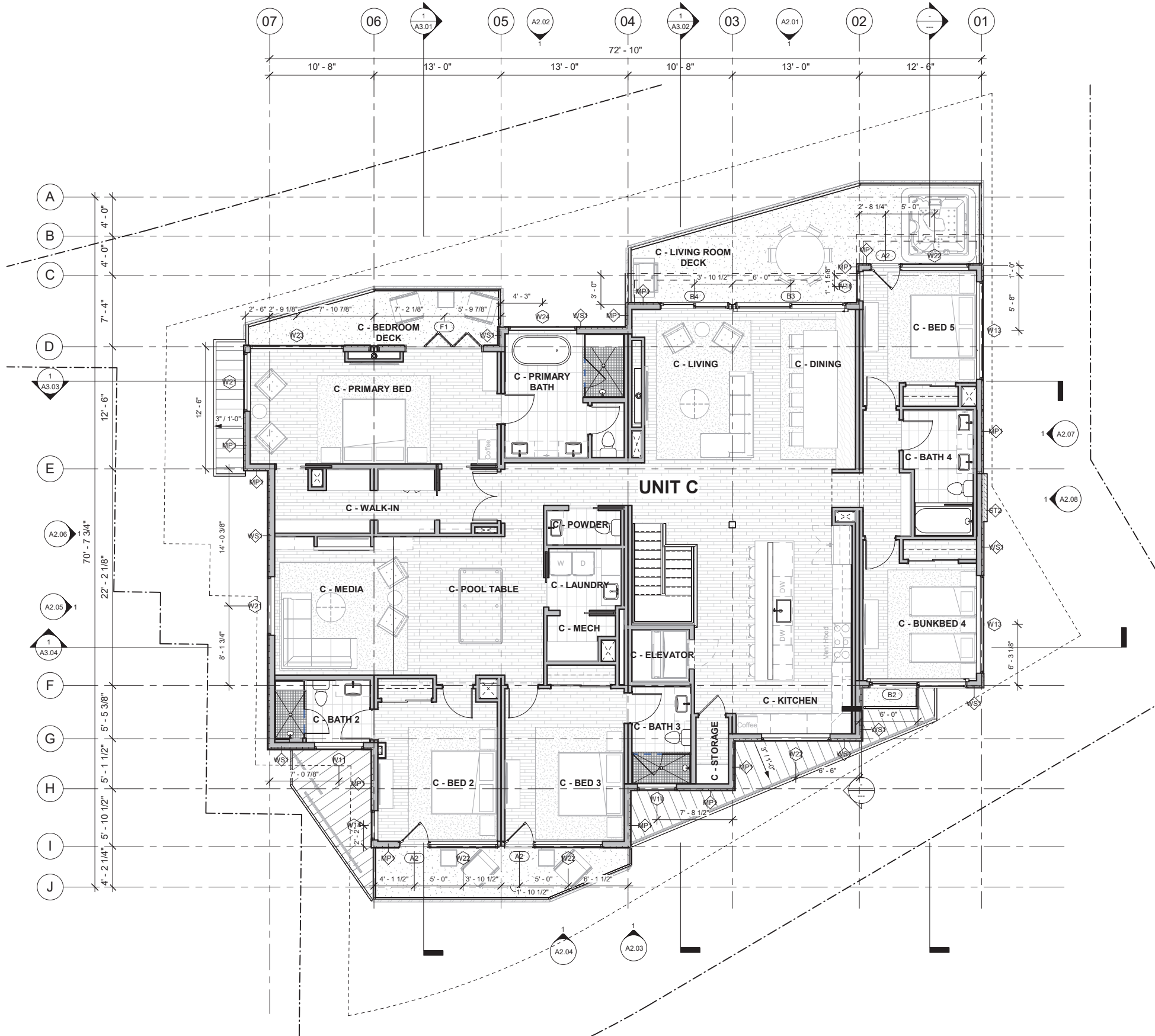

**NOTE:**  
 GRAY HATCH INDICATES SYSTEMS BUILT SCOPE, TYP.  
 CROSSHATCH INDICATES PANELIZED SCOPE, TYP.

- FLOOR PLAN GENERAL NOTES:**
1. ALL DIMENSIONS ARE TAKEN FROM FACE OF STUD, U.N.O.
  2. ALL GRIDLINES ALIGN WITH FACE OF STUD OR FACE OF STRUCTURE U.N.O. GRIDLINES DO NOT MATCH GRIDLINES FOR FOUNDATION PERMIT DRAWINGS
  3. KEYNOTES ARE SPECIFIC TO EACH DRAWING SHEET
  4. ALL INTERIOR WALL PARTITION TYPES ARE "TYPE A1" WHICH INCLUDE SOUND BATT INSULATION, U.N.O.
  5. ALL CLOSETS TO INCLUDE SHELF & ROD RE: INTERIOR DRAWINGS
  6. FURNITURE IS SHOWN FOR REFERENCE ONLY
  7. REFER TO THE A1 SERIES FOR UNIT PLANS, WHICH INCLUDE FLOOR PLAN, REFLECTED CEILING PLAN AND FINISH PLANS FOR EACH UNIT AND LEVEL
  8. REFER TO THE A2 SERIES FOR EXTERIOR ELEVATIONS AND FOR DESIGNATIONS OF EXTERIOR MATERIALS.
  9. REFER TO THE A3 SERIES FOR ALL BUILDING AND WALL SECTIONS
  10. REFER TO THE A5 AND A6 SERIES FOR DOOR AND WINDOW INFORMATION, SCHEDULES AND DETAILS
  11. REFER TO INTERIORS DRAWINGS FOR FINISH INFORMATION AND SCHEDULES
  12. ENSURE A HARDWIRED WITH BATTERY BACKUP SMOKE DETECTOR AND CARBON MONOXIDE DETECTOR IS INSTALLED ON EACH LEVEL IN A CENTRALLY LOCATED COMMON AREA PER IRC R314.6 AND NFPA 720 AND BE INTERCONNECTED PER IRC R314.4. SMOKE ALARMS SHALL BE PLACED NOT LESS THAN 3' FROM A BATHROOM DOOR WHEN THE BATHROOM CONTAINS A TUB OR SHOWER.
  13. FLOOR LEVELING MAY BE REQUIRED FOR TILE AND WOOD INSTALLATIONS THAT OCCUR AT SLAB ON GRADE CONDITIONS
  14. ALL EXPOSED CONCRETE FOUNDATION WALLS, CRAWLSPACES, AND FLOORS EXPOSED TO THE EXTERIOR ARE REQUIRED TO BE INSULATED PER THE 2021 IECC
  15. ALL CEILINGS TO BE GYPSUM WALL BOARD U.N.O.
  16. COORDINATE LOCATIONS FOR ACCESS DOORS WITH ALL FINAL MECHANICAL EQUIPMENT
  17. GUARDRAILS ARE REQUIRED AT ALL LOCATIONS WHERE THERE IS A GRADE CHANGE OF 30" OR MORE
  18. RE: ROOF DETAILS & DEMISING WALL DETAILS FOR TYPICAL DRAFT STOPPING/FIRE BLOCKING AT VERTICAL CHASES AT INTERMEDIATE FLOORS AND ROOF/CEILING INTERSECTIONS, AND FOR TYPICAL DRAFT STOPPING/FIRE BLOCKING AT SOFFITS. LUMINAIRES IN W/OT OF A DURABLE MATERIAL RATED FOR THESE LOCATIONS PER NEC 410.10.
  19. CARBON MONOXIDE ALARMS SHALL RECEIVE BATTERY PRIMARY POWER FROM THE BUILDING WIRING WITH BATTERY BACKUP AND ALL ALARMS WITHIN A DWELLING SHALL BE INTERCONNECTED PER NFPA 720.
  20. SLOPE GRADE AWAY FROM BUILDING 6" WITHIN THE FIRST 10' PER IRC R401.3. SLOPE EXTERIOR LANDINGS AND OTHER IMPERVIOUS SURFACES 2% PER IRC R511.3.
  21. LAP SIDING: PLANK BUTT JOINTS SHOULD BE TIGHT AND OCCUR ONLY AT STUDS OVER A 6" WIDE PIECE OF FLASHING LAPPED 1" OVER THE PLANK BELOW. FLASHING SHOULD BE OF A DURABLE WATERPROOF MATERIAL SUCH AS WINDOW FLASHING OR POLYOLEFIN WRB.
  22. ENSURE A WATER-RESISTIVE VAPOR-PERMEABLE BARRIER WITH A PERFORMANCE AT LEAST EQUIVALENT TO TWO LAYERS OF GRADE D PAPER IS PROVIDED PER IRC R703.7.3. AS UNDERLAYMENT FOR STUCCO. POLYMER-BASED WRB'S ARE EQUIVALENT TO GRADE D PAPER.
  23. WATER RESISTIVE BARRIER AT WALLS SHALL LAP A MIN. OF 2" HORIZONTALLY AND 6" VERTICALLY PER IRC R703.2. POLYMER BASED WRB'S SHALL LAP 6" MIN. HORIZONTALLY AND VERTICALLY.
  24. CONFER WITH AUTHORITY HAVING JURISDICTION TO DETERMINE IF RADON CONTROL METHODS ARE REQUIRED BY LOCAL ORDINANCE FOR NEW RESIDENTIAL CONSTRUCTION. REFER TO IRC APPENDIX F.
  25. ON WOOD FLOOR CONSTRUCTION, FILL VOIDS AT THE UNDERSIDE OF TUBS AND SHOWER PANS WITH INSULATION FOR ACOUSTIC DAMPENING.
  26. PROVIDE GLASS MAT GYP BD BACKING, FIBER-REINFORCED GYP BD, FIBER-CEMENT BOARD OR FIBER MAT REINFORCED CEMENT BOARD BACKER PANELS AT TUB AND SHOWER AREAS.
  27. RECESSED LUMINAIRES INSTALLED IN THE BUILDING THERMAL ENVELOPE SHALL BE IC-RATED FOR ZERO CLEARANCE INSULATION CONTACT AND SEALED AIR TIGHT.
  28. PROVIDE CLASS 1 VAPOR BARRIER OVER GRADE IN CRAWL SPACE. LAP UP FOUNDATION WALL MINIMUM 6" AND TAPE AND SEAM.

**1 LEVEL 04 OVERALL**  
 3/16" = 1'-0"

**359**  
 DESIGN

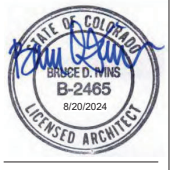

**LOT 165 CORTINA DRIVE**  
 Mountain Village, CO

No.	Description	Date

PROJECT NUMBER: 24102  
 SCALE DATE: 10/26/2024

**DRB PACKAGE**

**LEVEL 04 PLAN**

SHEET NO.

**A1.14**

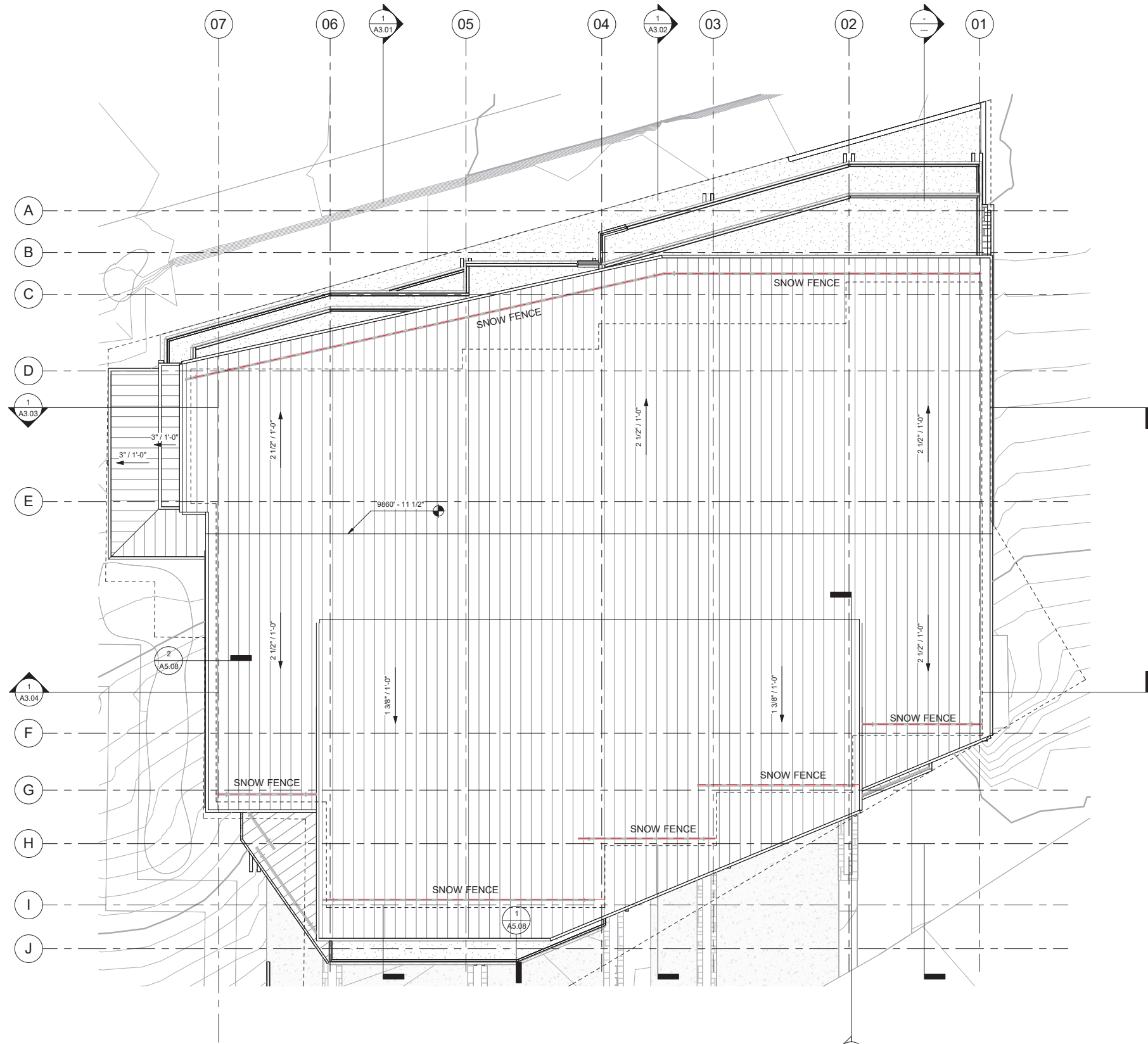

- FLOOR PLAN GENERAL NOTES:**
- ALL DIMENSIONS ARE TAKEN FROM FACE OF STUD, U.N.O.
  - ALL GRIDLINES ALIGN WITH FACE OF STUD OR FACE OF STRUCTURE U.N.O. GRIDLINES DO NOT MATCH GRIDLINES FOR FOUNDATION PERMIT DRAWINGS
  - KEYNOTES ARE SPECIFIC TO EACH DRAWING SHEET
  - ALL INTERIOR WALL PARTITION TYPES ARE "TYPE A1s" WHICH INCLUDE SOUND BATT INSULATION, U.N.O.
  - ALL CLOSETS TO INCLUDE SHELF & ROD RE: INTERIOR DRAWINGS
  - FURNITURE IS SHOWN FOR REFERENCE ONLY
  - REFER TO THE A1 SERIES FOR UNIT PLANS, WHICH INCLUDE FLOOR PLAN, REFLECTED CEILING PLAN AND FINISH PLANS FOR EACH UNIT AND LEVEL
  - REFER TO THE A2 SERIES FOR EXTERIOR ELEVATIONS AND FOR DESIGNATIONS OF EXTERIOR MATERIALS.
  - REFER TO THE A3 SERIES FOR ALL BUILDING AND WALL SECTIONS
  - REFER TO THE A5 AND A6 SERIES FOR DOOR AND WINDOW INFORMATION, SCHEDULES AND DETAILS
  - REFER TO INTERIORS DRAWINGS FOR FINISH INFORMATION AND SCHEDULES
  - ENSURE A HARDWIRED WITH BATTERY BACKUP SMOKE DETECTOR AND CARBON MONOXIDE DETECTOR IS INSTALLED ON EACH LEVEL IN A CENTRALLY LOCATED COMMON AREA PER IRC R314.6 AND NFPA 720 AND BE INTERCONNECTED PER IRC R314.4. SMOKE ALARMS SHALL BE PLACED NOT LESS THAN 7' FROM A BATHROOM DOOR WHEN THE BATHROOM CONTAINS A TUB OR SHOWER.
  - FLOOR LEVELING MAY BE REQUIRED FOR TILE AND WOOD INSTALLATIONS THAT OCCUR AT SLAB ON GRADE CONDITIONS
  - ALL EXPOSED CONCRETE FOUNDATION WALLS, CRAWLSPACES, AND FLOORS EXPOSED TO THE EXTERIOR ARE REQUIRED TO BE INSULATED PER THE 2021 IECC
  - ALL CEILINGS TO BE GYPSUM WALL BOARD U.N.O.
  - COORDINATE LOCATIONS FOR ACCESS DOORS WITH ALL FINAL MECHANICAL EQUIPMENT
  - GUARDRAILS ARE REQUIRED AT ALL LOCATIONS WHERE THERE IS A GRADE CHANGE OF 30" OR MORE
  - RE: ROOF DETAILS & DEMISING WALL DETAILS FOR TYPICAL DRAFT STOPPING/FIRE BLOCKING AT VERTICAL CHASES AT INTERMEDIATE FLOORS AND ROOF/CEILING INTERSECTIONS, AND FOR TYPICAL DRAFT STOPPING/FIRE BLOCKING AT SOFFITS
  - LUMINAIRES IN WET OR DAMP LOCATIONS TO RATED FOR THESE LOCATIONS PER NEC 410.10.
  - CARBON MONOXIDE ALARMS SHALL RECEIVE BATTERY PRIMARY POWER FROM THE BUILDING WIRING WITH BATTERY BACKUP AND ALL ALARMS WITHIN A DWELLING SHALL BE INTERCONNECTED PER NFPA 720.
  - SLOPE GRADE AWAY FROM BUILDING 6" WITHIN THE FIRST 10' PER IRC R401.3. SLOPE EXTERIOR LANDINGS AND OTHER IMPERVIOUS SURFACES 2% PER IRC R311.3.
  - LAP SIDING: PLANK BUTT JOINTS SHOULD BE TIGHT AND OCCUR ONLY AT STUDS OVER A 6" WIDE PIECE OF FLASHING LAPPED 1" OVER THE PLANK BELOW. FLASHING SHOULD BE OF A DURABLE WATERPROOF MATERIAL SUCH AS WINDOW FLASHING OR POLYOLEFIN WRB.
  - ENSURE A WATER-RESISTIVE VAPOR-PERMEABLE BARRIER WITH A PERFORMANCE AT LEAST EQUIVALENT TO TWO LAYERS OF GRADE D PAPER IS PROVIDED PER IRC R703.7.3. AS UNDERLAYMENT FOR STUCCO. POLYMER-BASED WRB'S ARE EQUIVALENT TO GRADE D PAPER.
  - WATER RESISTIVE BARRIER AT WALLS SHALL LAP A MIN. OF 2" HORIZONTALLY AND 6" VERTICALLY PER IRC R703.2. POLYMER BASED WRB'S SHALL LAP 6" MIN. HORIZONTALLY AND VERTICALLY.
  - CONFER WITH AUTHORITY HAVING JURISDICTION TO DETERMINE IF RADON CONTROL METHODS ARE REQUIRED BY LOCAL ORDINANCE FOR NEW RESIDENTIAL CONSTRUCTION. REFER TO IRC APPENDIX F.
  - ON WOOD FLOOR CONSTRUCTION, FILL VOIDS AT THE UNDERSIDE OF TUBS AND SHOWER PANS WITH INSULATION FOR ACOUSTIC DAMPENING.
  - PROVIDE GLASS MAT GYP BD BACKING, FIBER-REINFORCED GYP BD, FIBER-CEMENT BOARD OR FIBER MAT REINFORCED CEMENT BOARD BACKER PANELS AT TUB AND SHOWER AREAS.
  - RECESSED LUMINAIRES INSTALLED IN THE BUILDING THERMAL ENVELOPE SHALL BE IC-RATED FOR ZERO CLEARANCE INSULATION CONTACT AND SEALED AIR TIGHT.
  - PROVIDE CLASS I VAPOR BARRIER OVER GRADE IN CRAWL SPACE. LAP UP FOUNDATION WALL MINIMUM 6" AND TAPE AND SEAM.

**1 ROOF PLAN**  
3/16" = 1'-0"

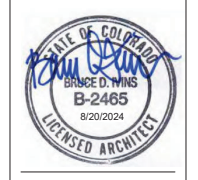

**LOT 165 CORTINA DRIVE**  
Mountain Village, CO

No.	Description	Date

PROJECT NUMBER: 24102  
SCALE DATE: 10/28/2024

DRB PACKAGE

ROOF PLAN

**A1.15**



AVERAGE BUILDING HEIGHT  
40' - 7"

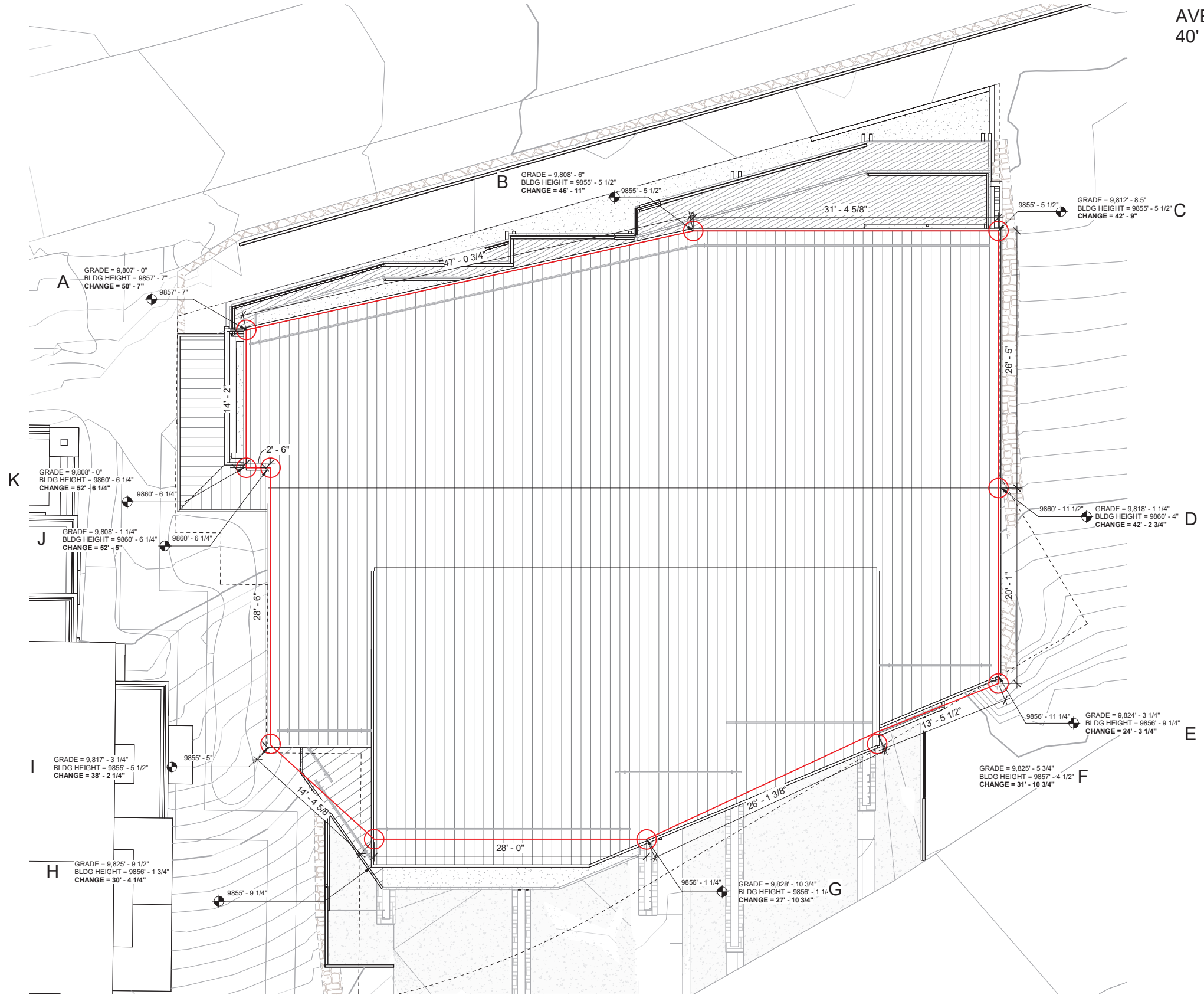

**1 ROOF BASE - AVERAGE BUILDING HEIGHT**  
3/16" = 1'-0"



**LOT 165 CORTINA DRIVE**  
Mountain Village, CO

No.	Description	Date

PROJECT NUMBER: 24102  
DATE: 10/29/2024

DRB PACKAGE

SHEET TITLE:  
**AVERAGE BUILDING HEIGHT - ROOF PLAN**

**NOTE:**  
 GRAY HATCH INDICATES SYSTEMS BUILT SCOPE, TYP.  
 CROSSHATCH INDICATES PANELIZED SCOPE, TYP.

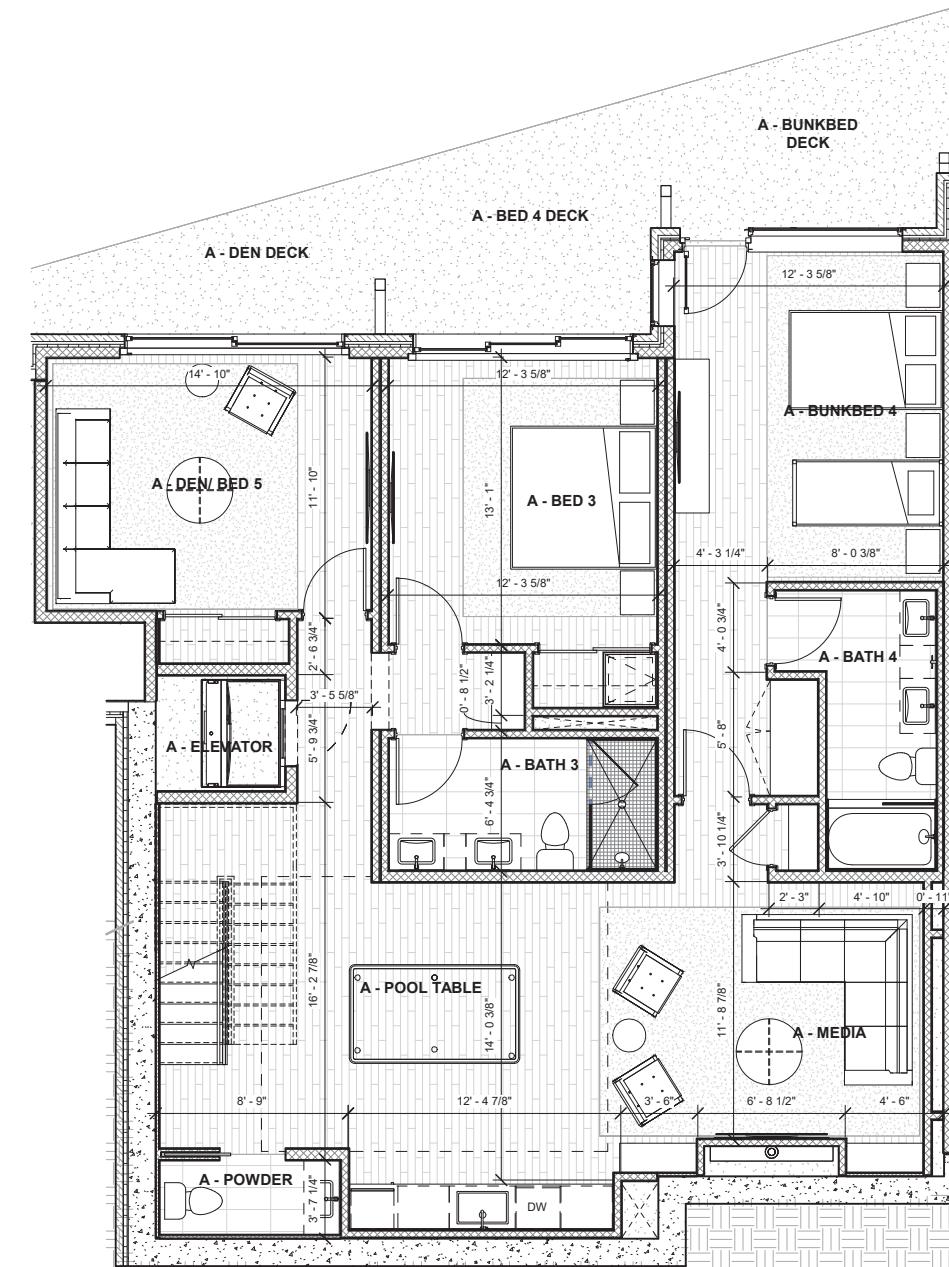

**1 LEVEL 01- UNIT A**  
 1/4" = 1'-0"

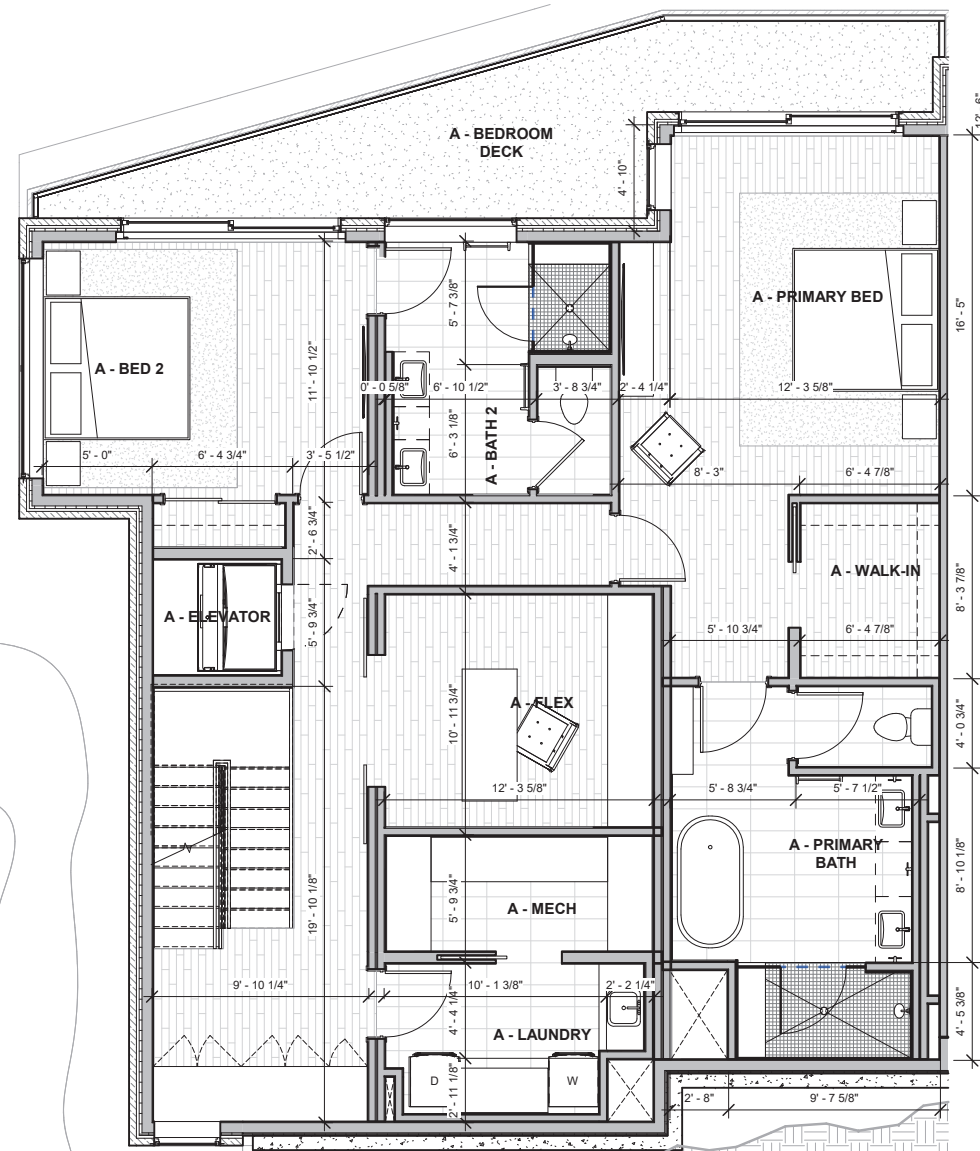

**2 LEVEL 02- UNIT A**  
 1/4" = 1'-0"

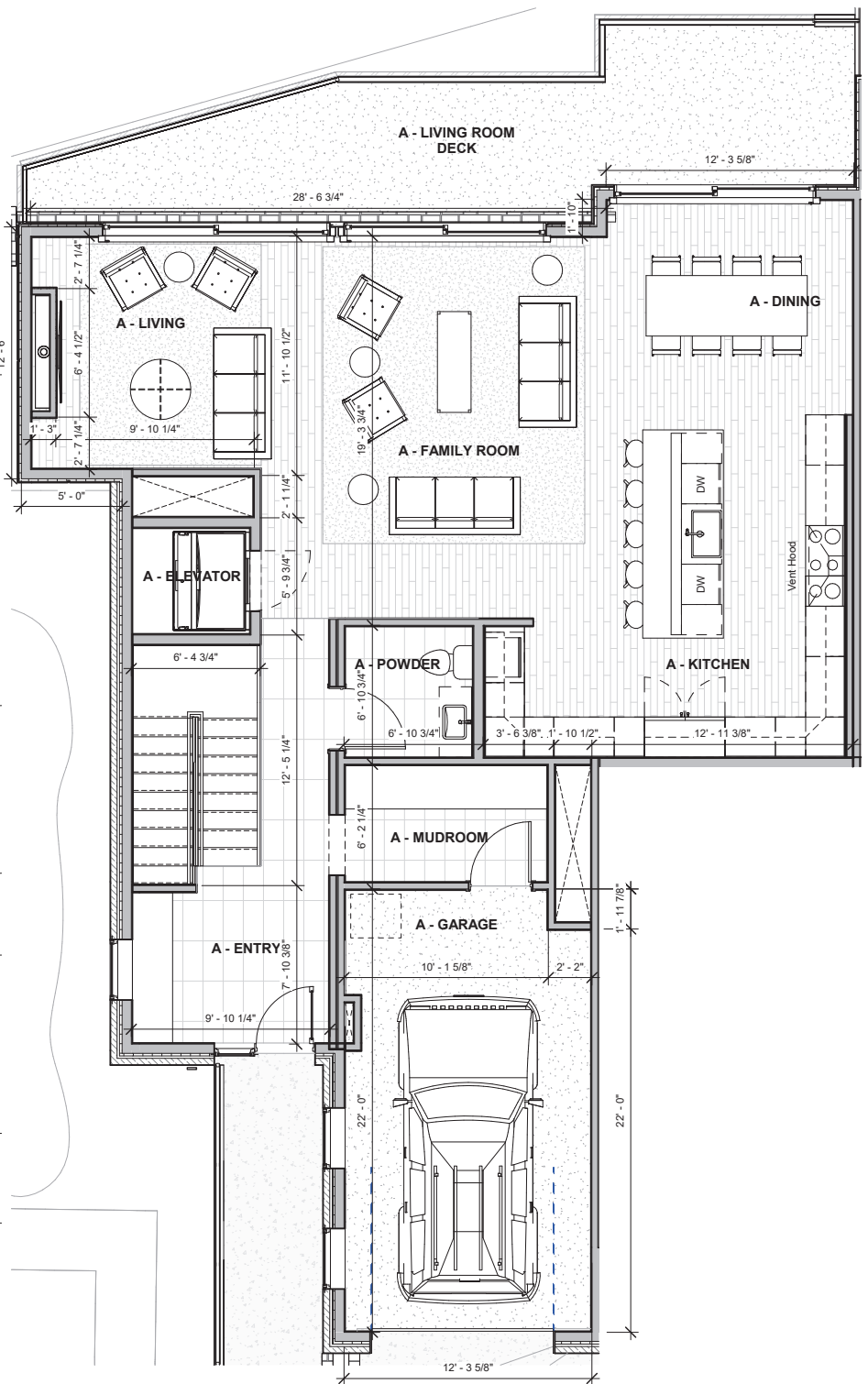

**3 LEVEL 03- UNIT A**  
 1/4" = 1'-0"

**359**  
 DESIGN



**LOT 165 CORTINA DRIVE**  
 Mountain Village, CO

No.	Description	Date

PROJECT NUMBER: 24102  
 DATE: 10/28/2024

DRB PACKAGE

SHEET TITLE: UNIT A - DIM PLANS

SHEET NO: A1.21

**NOTE:**  
 GRAY HATCH INDICATES SYSTEMS BUILT SCOPE, TYP.  
 CROSSHATCH INDICATES PANELIZED SCOPE, TYP.

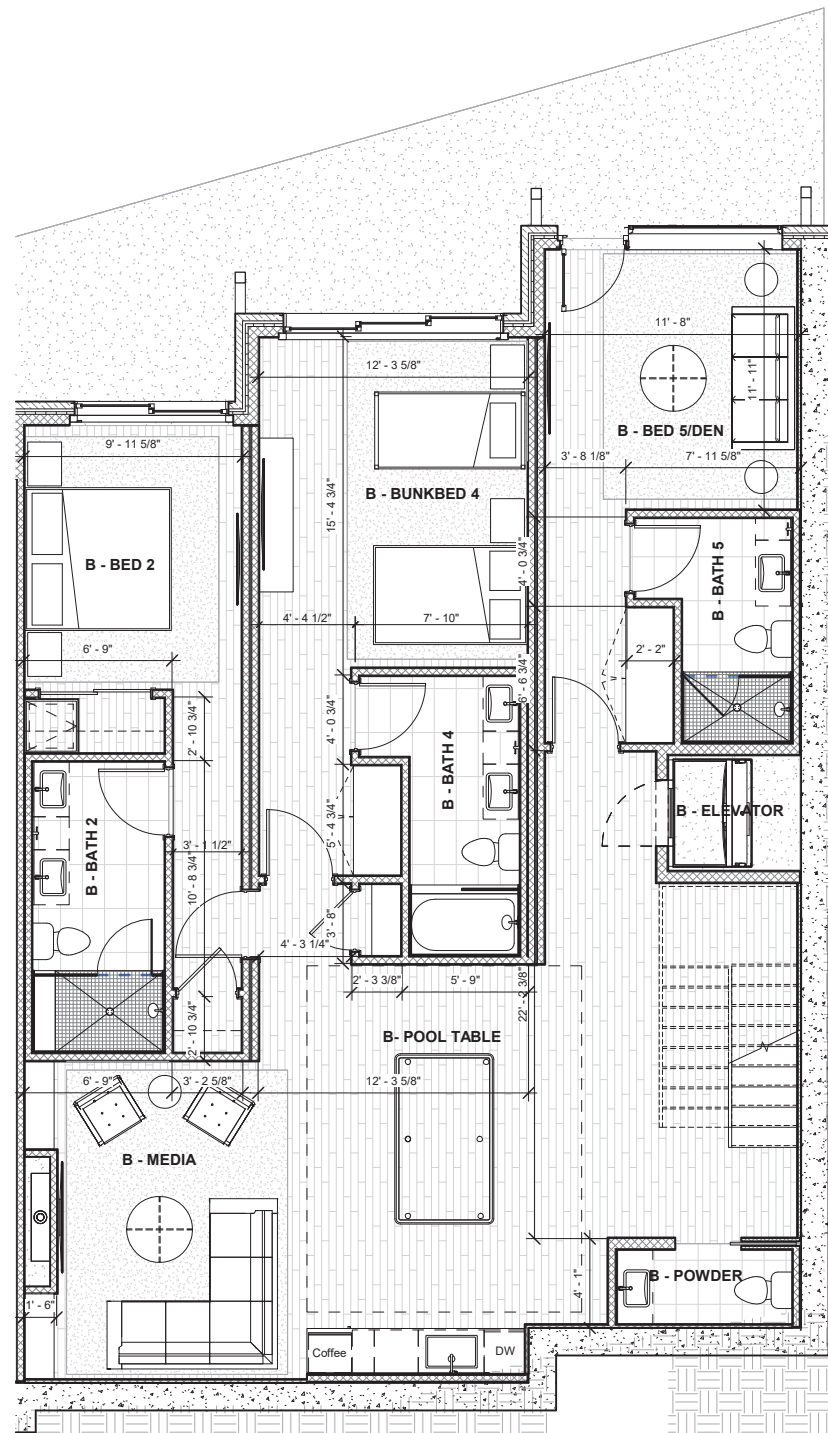

**1 LEVEL 01- UNIT B**  
 1/4" = 1'-0"

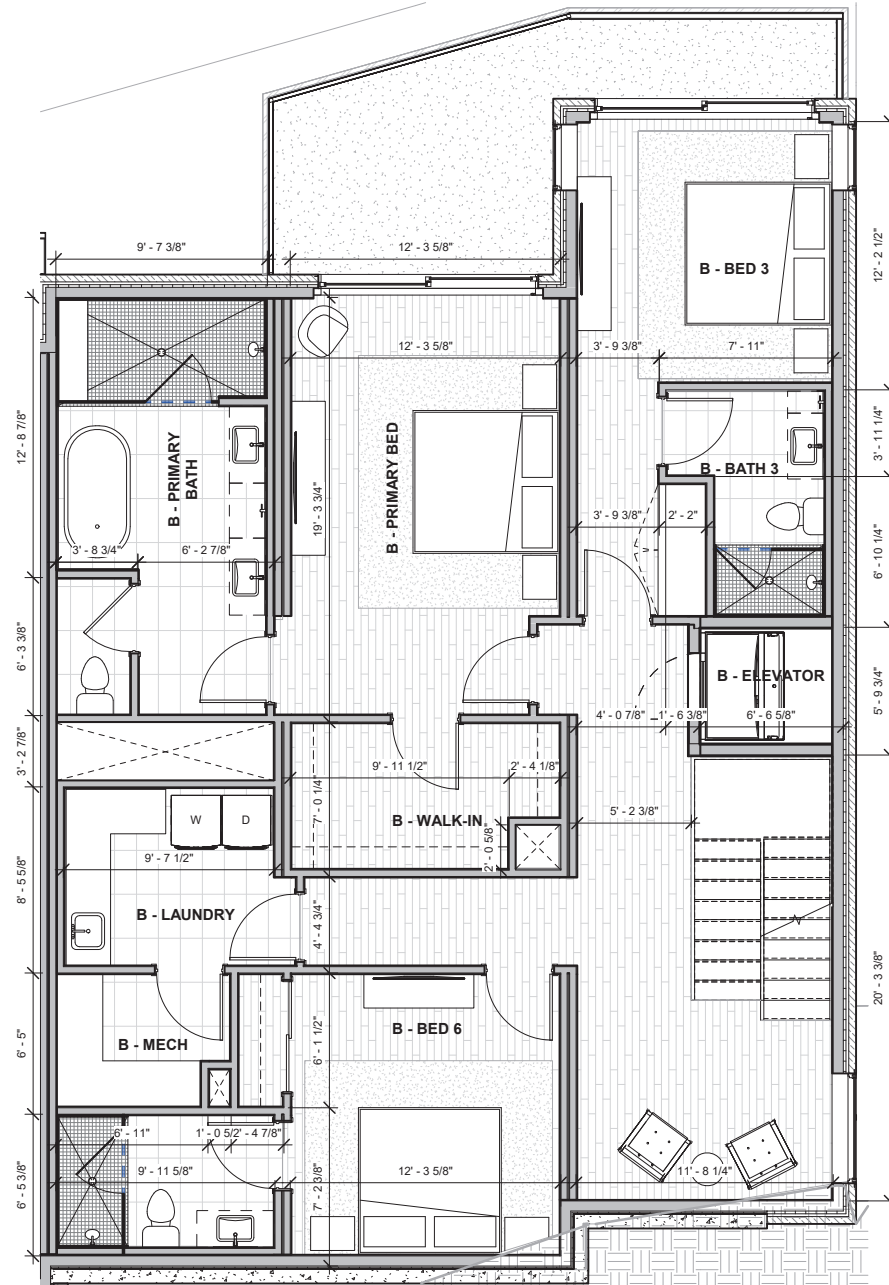

**2 LEVEL 02- UNIT B**  
 1/4" = 1'-0"

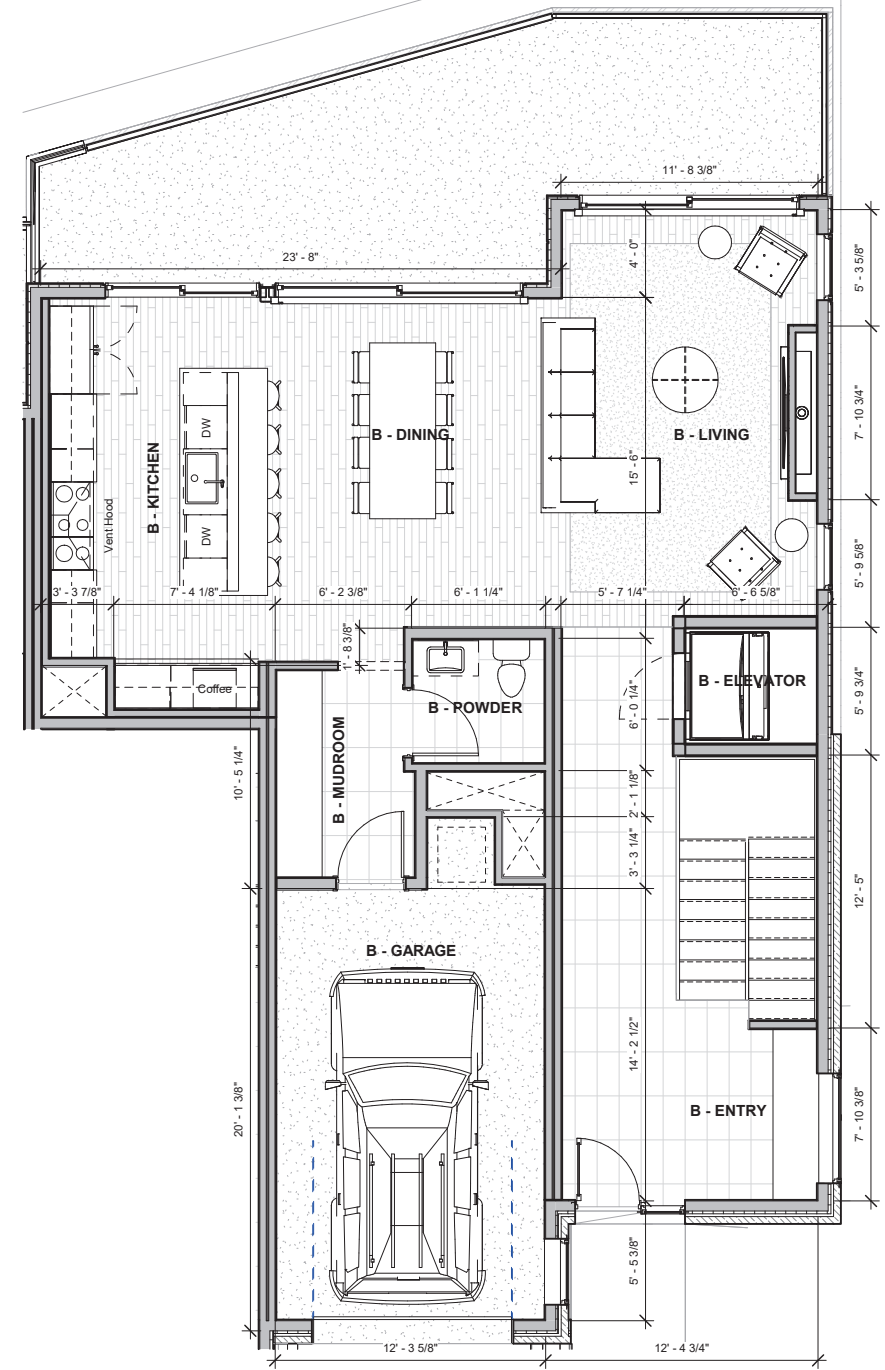

**3 LEVEL 03- UNIT B**  
 1/4" = 1'-0"

**359**  
 DESIGN

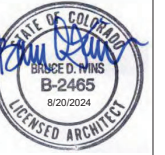

**LOT 165 CORTINA DRIVE**

Mountain Village, CO

No.	Description	Date

PROJECT NUMBER: 24102  
 DATE: 10/08/2024

DRB PACKAGE

UNIT B - DIM PLANS

**A1.31**

**NOTE:**  
 GRAY HATCH INDICATES SYSTEMS BUILT SCOPE, TYP.  
 CROSSHATCH INDICATES PANELIZED SCOPE, TYP.

**359**  
 DESIGN



**LOT 165 CORTINA DRIVE**  
 Mountain Village, CO

No.	Description	Date

PROJECT NUMBER: 24102  
 SCALE DATE: 10/28/2024

**DRB PACKAGE**

**UNIT C - DIM PLANS**

**A1.41**

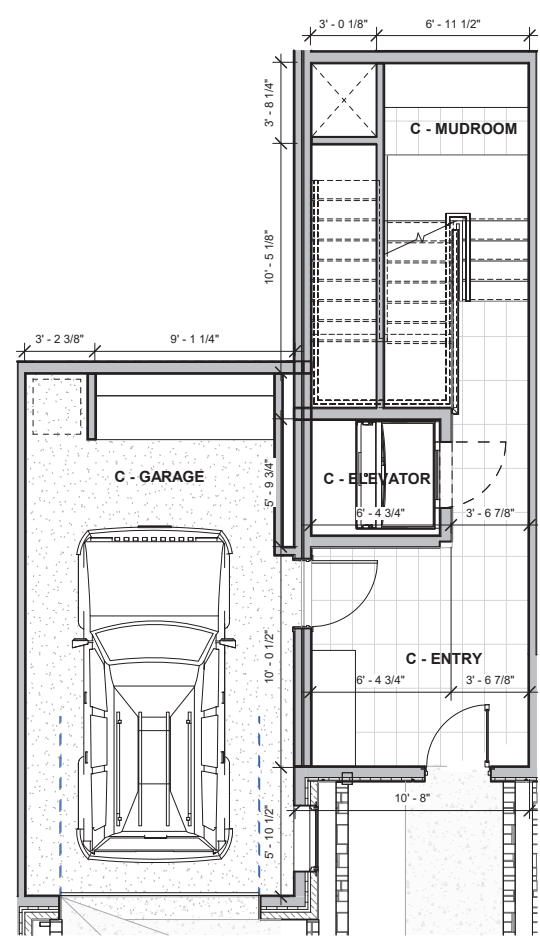

**UNIT C**

**1 LEVEL 03- UNIT C**  
 1/4" = 1'-0"

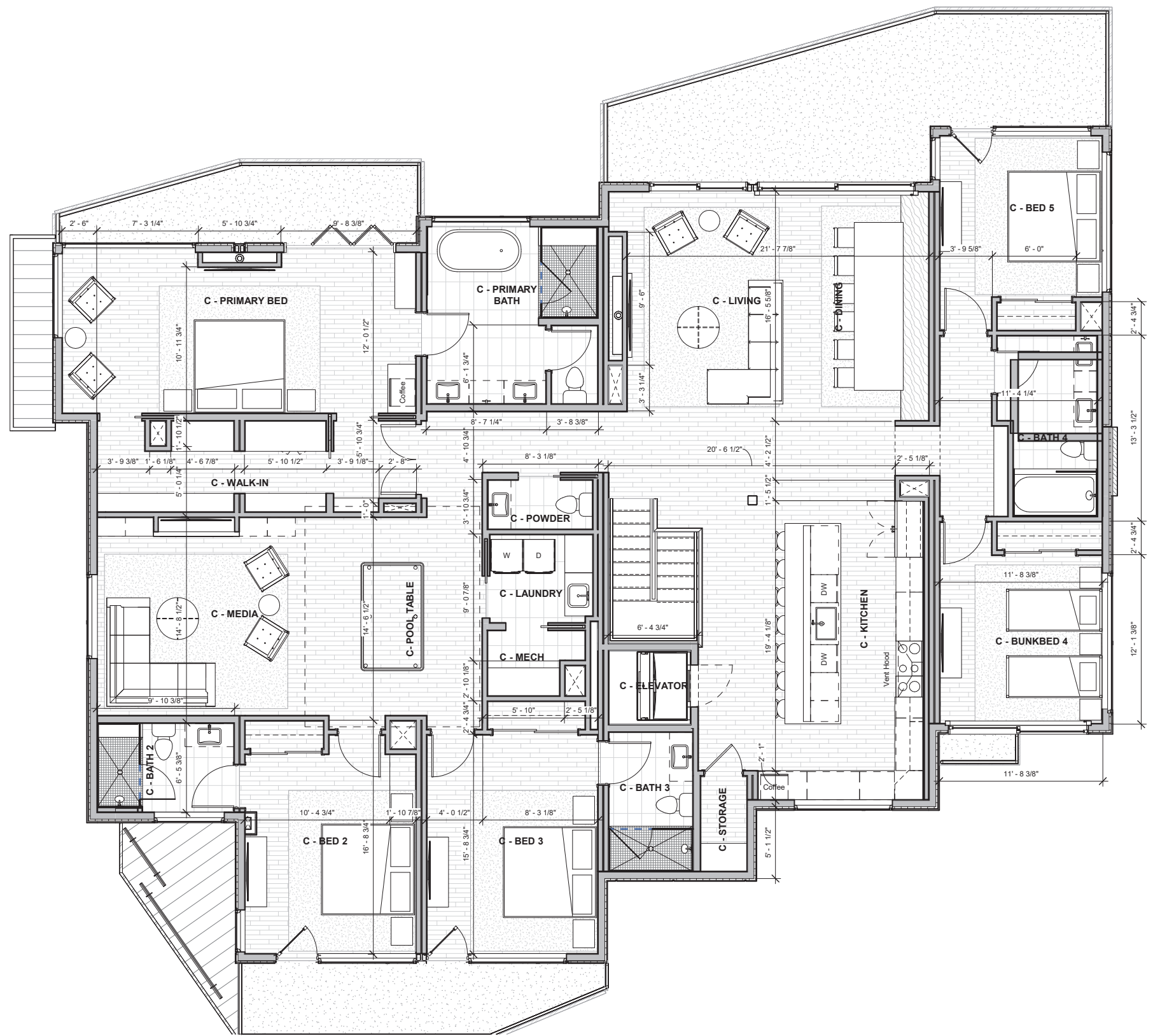



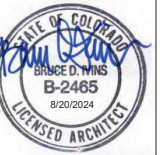





**2 LEVEL 04- UNIT C**  
 1/4" = 1'-0"

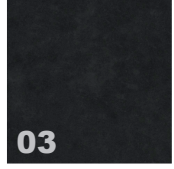

**LOT 165 CORTINA DRIVE**  
Mountain Village, CO



 <p><b>01</b> <b>STONE SIDING:</b> Locally quarried weathered edge stone pattern</p>	<p>MATERIAL SF FRONT ELEVATION = 889.94 ELEVATION OVERALL SF = 3482.74 <b>MATERIAL % FRONT ELEVATION = 26%</b></p> <p>MATERIAL SF OVERALL = 3511.11 BUILDING PERIMETER SF = 9915.09 <b>MATERIAL % OVERALL = 35% (MIN. 35%)</b></p>	
 <p><b>02</b> <b>WOOD SIDING:</b> 6" horizontal SPF (spruce, pine, fir mix) wood siding</p>	<p>MATERIAL SF FRONT ELEVATION = 177.09 SF ELEVATION OVERALL SF = 3482.74 <b>MATERIAL % FRONT ELEVATION = 5%</b></p> <p>MATERIAL SF OVERALL = 1339.77 SF BUILDING PERIMETER SF = 9915.09 SF <b>MATERIAL % OVERALL = 14%</b></p>	
 <p><b>03</b> <b>METAL SIDING:</b> Corrosion-resistant charcoal grey vertical metal panel siding</p>	<p>MATERIAL SF FRONT ELEVATION = 566.35 SF ELEVATION OVERALL SF = 3482.74 SF <b>MATERIAL % FRONT ELEVATION = 16%</b></p> <p>MATERIAL SF OVERALL = 2307.78 SF BUILDING PERIMETER SF = 9915.09 SF <b>MATERIAL % OVERALL = 23%</b></p>	
 <p><b>04</b> <b>GLAZING:</b> High energy double-pane low-e glazing</p>	<p>MATERIAL SF FRONT ELEVATION = 1849.36 SF ELEVATION OVERALL SF = 3482.74 SF <b>MATERIAL % FRONT ELEVATION = 53%</b></p> <p>MATERIAL SF OVERALL = 2756.43 SF BUILDING PERIMETER SF = 9915.09 SF <b>MATERIAL % OVERALL = 28%</b></p>	
 <p><b>05</b> <b>FASCIA:</b> Dark-grey painted hardie board</p>	 <p><b>06</b> <b>SOFFIT:</b> 4" shiplap clearcoat soffit</p>	 <p><b>07</b> <b>PAVERS:</b> Citystone 12x24 stone pavers</p>
 <p><b>08</b> <b>RAILINGS:</b> Cable railing with 2x2 metal balusters</p>	 <p><b>09</b> <b>ROOF:</b> Dark-Grey Non-Reflective Standing Seam Roof</p>	

REVISIONS

No.	Description	Date



**LOT 165 CORTINA DRIVE**  
Mountain Village, CO



**1 FRONT ELEVATION - B&W**  
3/16" = 1'-0"

REVISIONS

No.	Description	Date

PROJECT NUMBER: 24102  
DATE: 10/28/2024

DRB PACKAGE





SHEET TITLE:  
**FRONT ELEVATION - B&W**

SHEET NO:  
**A2.02**





**1 BACK ELEVATION - RENDERED**

3/16" = 1'-0"

 <p><b>01</b> <b>STONE SIDING:</b> Locally quarried weathered edge stone pattern</p>	<p>MATERIAL SF BACK ELEVATION = 369.07 ELEVATION OVERALL SF = 1645.58 <b>MATERIAL % BACK ELEVATION = 22%</b></p> <p>MATERIAL SF OVERALL = 3511.11 BUILDING PERIMETER SF = 9915.09 <b>MATERIAL % OVERALL = 35% (MIN. 35%)</b></p>
 <p><b>02</b> <b>WOOD SIDING:</b> 6" horizontal SPF (spruce, pine, fir mix) wood siding</p>	<p>MATERIAL SF BACK ELEVATION = 314.66 SF ELEVATION OVERALL SF = 1645.58 SF <b>MATERIAL % BACK ELEVATION = 19%</b></p> <p>MATERIAL SF OVERALL = 1339.77 SF BUILDING PERIMETER SF = 9915.09 SF <b>MATERIAL % OVERALL = 14%</b></p>
 <p><b>03</b> <b>METAL SIDING:</b> Corrosion-resistant charcoal grey vertical metal panel siding</p>	<p>MATERIAL SF BACK ELEVATION = 462.24 SF ELEVATION OVERALL SF = 1645.58 SF <b>MATERIAL % BACK ELEVATION = 28%</b></p> <p>MATERIAL SF OVERALL = 2307.78 SF BUILDING PERIMETER SF = 9915.09 SF <b>MATERIAL % OVERALL = 23%</b></p>
 <p><b>04</b> <b>GLAZING:</b> High energy double-pane low-e glazing</p>	<p>MATERIAL SF BACK ELEVATION = 499.61 SF ELEVATION OVERALL SF = 1645.58 SF <b>MATERIAL % BACK ELEVATION = 30%</b></p> <p>MATERIAL SF OVERALL = 2756.43 SF BUILDING PERIMETER SF = 9915.09 SF <b>MATERIAL % OVERALL = 28%</b></p>

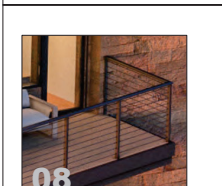
 <p><b>05</b> <b>FASCIA:</b> Dark-grey painted hardie board</p>	 <p><b>06</b> <b>SOFFIT:</b> 4" shiplap clearcoat soffit</p>	 <p><b>07</b> <b>PAVERS:</b> Citystone 12x24 stone pavers</p>
--	---	--

 <p><b>08</b> <b>RAILINGS:</b> Cable railing with 2x2 metal balusters</p>	 <p><b>09</b> <b>ROOF:</b> Dark-Grey Non-Reflective Standing Seam Roof</p>
--	---

No.	Description	Date

PROJECT NUMBER: 24102  
DATE: 10/28/2024

**DRB PACKAGE**

**BACK ELEVATION - MATERIALS**

SHEET NO.

**A2.03**

TOWN STAMP

**359**  
DESIGN

348 HENNESSY CT SUITE 201  
DENVER, CO 80202  
TEL: 303.343.7777



**LOT 165 CORTINA DRIVE**  
Mountain Village, CO

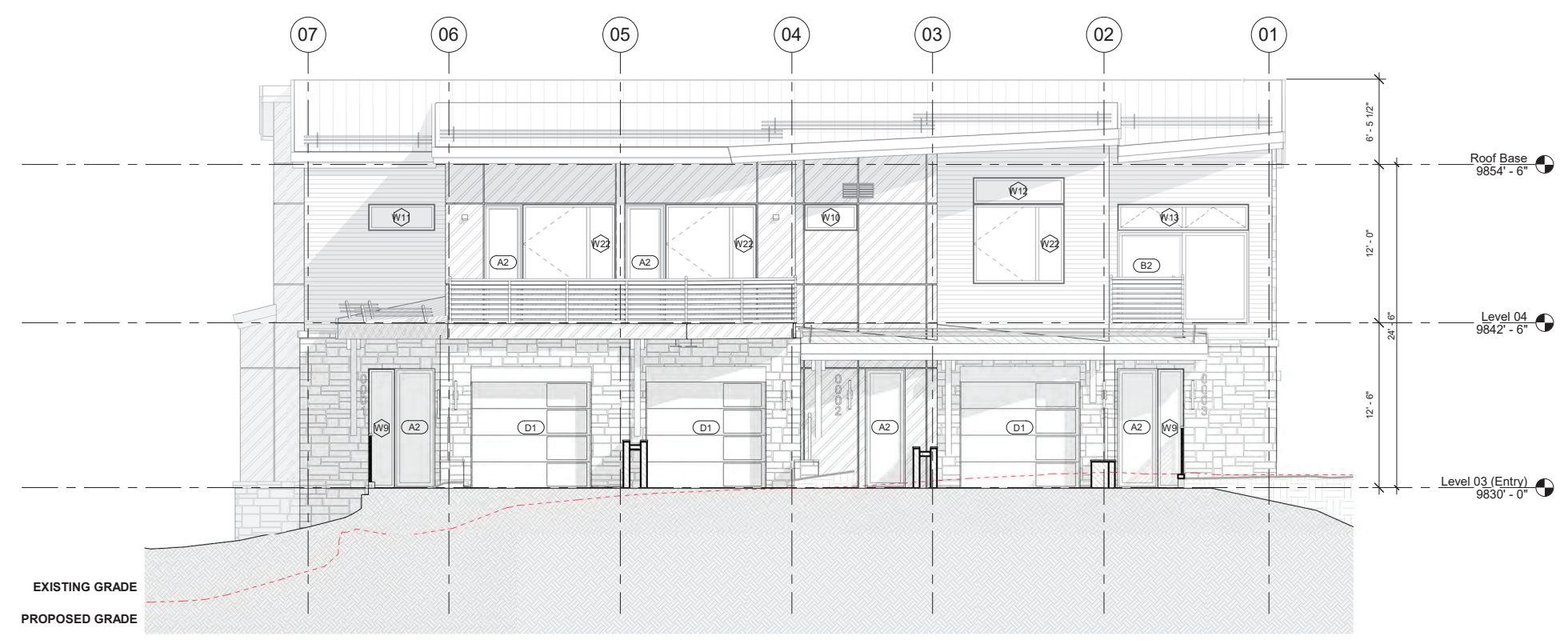

**1 BACK ELEVATION - B&W**  
3/16" = 1'-0"

No.	Description	Date

PROJECT NUMBER: 24102  
DATE: 10/28/2024

DRB PACKAGE







BACK ELEVATION - B&W

**A2.04**



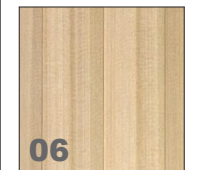

**1 RIGHT ELEVATION - RENDERED**  
3/16" = 1'-0"

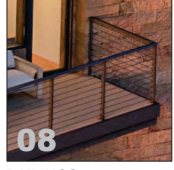
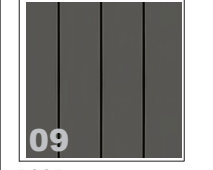
 <p><b>01</b> <b>STONE SIDING:</b> Locally quarried weathered edge stone pattern</p>	<p>MATERIAL SF RIGHT ELEVATION = 1347 ELEVATION OVERALL SF = 2596.79 <b>MATERIAL % RIGHT ELEVATION = 52%</b></p> <p>MATERIAL SF OVERALL = 3511.11 BUILDING PERIMETER SF = 9915.09 <b>MATERIAL % OVERALL = 35% (MIN. 35%)</b></p>	
 <p><b>02</b> <b>WOOD SIDING:</b> 6" horizontal SPF (spruce, pine, fir mix) wood siding</p>	<p>MATERIAL SF RIGHT ELEVATION = 518.76 SF ELEVATION OVERALL SF = 2596.79 SF <b>MATERIAL % RIGHT ELEVATION = 20%</b></p> <p>MATERIAL SF OVERALL = 1339.77 SF BUILDING PERIMETER SF = 9915.09 SF <b>MATERIAL % OVERALL = 14%</b></p>	
 <p><b>03</b> <b>METAL SIDING:</b> Corrosion-resistant charcoal grey vertical metal panel siding</p>	<p>MATERIAL SF RIGHT ELEVATION = 494.57 SF ELEVATION OVERALL SF = 2596.79 SF <b>MATERIAL % RIGHT ELEVATION = 19%</b></p> <p>MATERIAL SF OVERALL = 2307.78 SF BUILDING PERIMETER SF = 9915.09SF <b>MATERIAL % OVERALL = 23%</b></p>	
 <p><b>04</b> <b>GLAZING:</b> High energy double-pane low-e glazing</p>	<p>MATERIAL SF RIGHT ELEVATION = 236.46 SF ELEVATION OVERALL SF = 2596.79 SF <b>MATERIAL % RIGHT ELEVATION = 9%</b></p> <p>MATERIAL SF OVERALL = 2756.43 SF BUILDING PERIMETER SF = 9915.09 SF <b>MATERIAL % OVERALL = 28%</b></p>	
 <p><b>05</b> <b>FASCIA:</b> Dark-grey painted hardie board</p>	 <p><b>06</b> <b>SOFFIT:</b> 4" shiplap clearcoat soffit</p>	 <p><b>07</b> <b>PAVERS:</b> Citystone 12x24 stone pavers</p>
 <p><b>08</b> <b>RAILINGS:</b> Cable railing with 2x2 metal balusters</p>	 <p><b>09</b> <b>ROOF:</b> Dark-Grey Non-Reflective Standing Seam Roof</p>	

REVISIONS

No.	Description	Date

PROJECT NUMBER: 24102  
DATE: 10/28/2024

DRB PACKAGE

SHEET TITLE  
**RIGHT ELEVATION - MATERIALS**

SHEET NO.

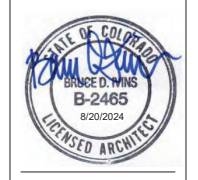

**LOT 165 CORTINA DRIVE**  
Mountain Village, CO

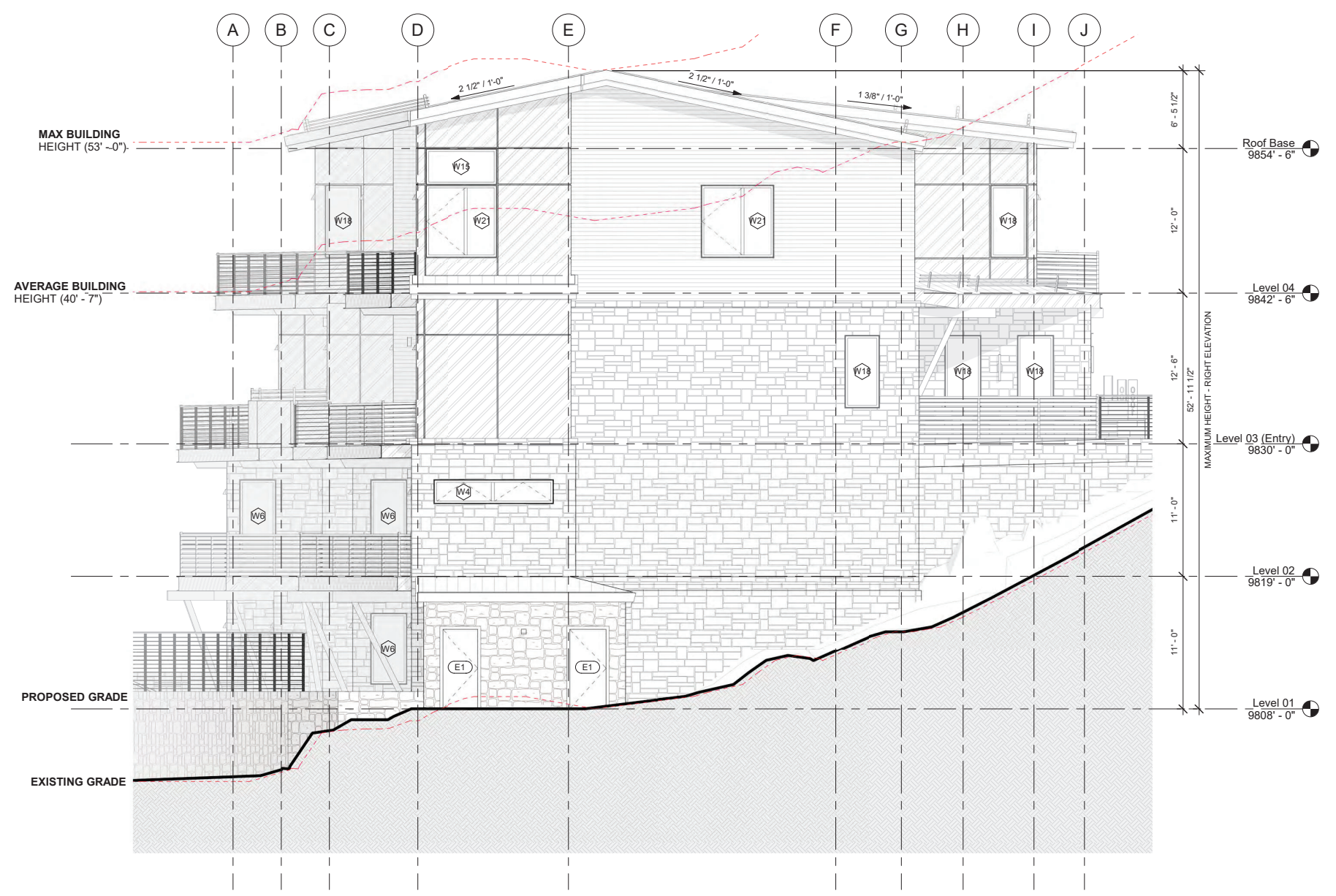

**1 RIGHT ELEVATION - B&W**  
3/16" = 1'-0"

REVISIONS

No.	Description	Date

PROJECT NUMBER: 24102  
DATE: 10/28/2024

DRB PACKAGE

SHEET TITLE:  
**RIGHT ELEVATION - B&W**



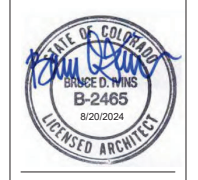



SHEET NO:  
**A2.06**



**LOT 165 CORTINA DRIVE**  
Mountain Village, CO

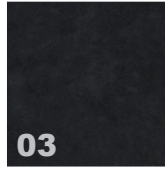

**1 LEFT ELEVATION - RENDERED**  
3/16" = 1'-0"

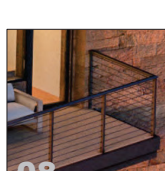
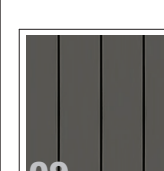
 <p><b>01</b> <b>STONE SIDING:</b> Locally quarried weathered edge stone pattern</p>	<p>MATERIAL SF LEFT ELEVATION = 905.10 ELEVATION OVERALL SF = 2189.98 <b>MATERIAL % RIGHT ELEVATION = 41%</b></p> <p>MATERIAL SF OVERALL = 3511.11 BUILDING PERIMETER SF = 9915.09 <b>MATERIAL % OVERALL = 35% (MIN. 35%)</b></p>
 <p><b>02</b> <b>WOOD SIDING:</b> 6" horizontal SPF (spruce, pine, fir mix) wood siding</p>	<p>MATERIAL SF LEFT ELEVATION = 329.26 SF ELEVATION OVERALL SF = 2189.98 SF <b>MATERIAL % LEFT ELEVATION = 15%</b></p> <p>MATERIAL SF OVERALL = 1339.77 SF BUILDING PERIMETER SF = 9915.09 SF <b>MATERIAL % OVERALL = 14%</b></p>
 <p><b>03</b> <b>METAL SIDING:</b> Corrosion-resistant charcoal grey vertical metal panel siding</p>	<p>MATERIAL SF LEFT ELEVATION = 784.62 SF ELEVATION OVERALL SF = 2189.98 SF <b>MATERIAL % LEFT ELEVATION = 36%</b></p> <p>MATERIAL SF OVERALL = 2307.78 SF BUILDING PERIMETER SF = 9915.09 SF <b>MATERIAL % OVERALL = 23%</b></p>
 <p><b>04</b> <b>GLAZING:</b> High energy double-pane low-e glazing</p>	<p>MATERIAL SF RIGHT ELEVATION = 171 SF ELEVATION OVERALL SF = 2189.98 SF <b>MATERIAL % RIGHT ELEVATION = 8%</b></p> <p>MATERIAL SF OVERALL = 2756.43 SF BUILDING PERIMETER SF = 9915.09 SF <b>MATERIAL % OVERALL = 28%</b></p>
 <p><b>05</b> <b>FASCIA:</b> Dark-grey painted hardie board</p>	 <p><b>06</b> <b>SOFFIT:</b> 4" shiplap clearcoat soffit</p>  <p><b>07</b> <b>PAVERS:</b> Citystone 12x24 stone pavers</p>
 <p><b>08</b> <b>RAILINGS:</b> Cable railing with 2x2 metal balusters</p>	 <p><b>09</b> <b>ROOF:</b> Dark-Grey Non-Reflective Standing Seam Roof</p>

REVISIONS

No.	Description	Date

PROJECT NUMBER: 24192  
DATE: 10/28/2024

DRB PACKAGE

SHEET TITLE:  
**LEFT ELEVATION - MATERIALS**

SHEET NO:  
**A2.07**

MAX BUILDING  
HEIGHT (53' - 0")

AVERAGE BUILDING  
HEIGHT (40' - 7")

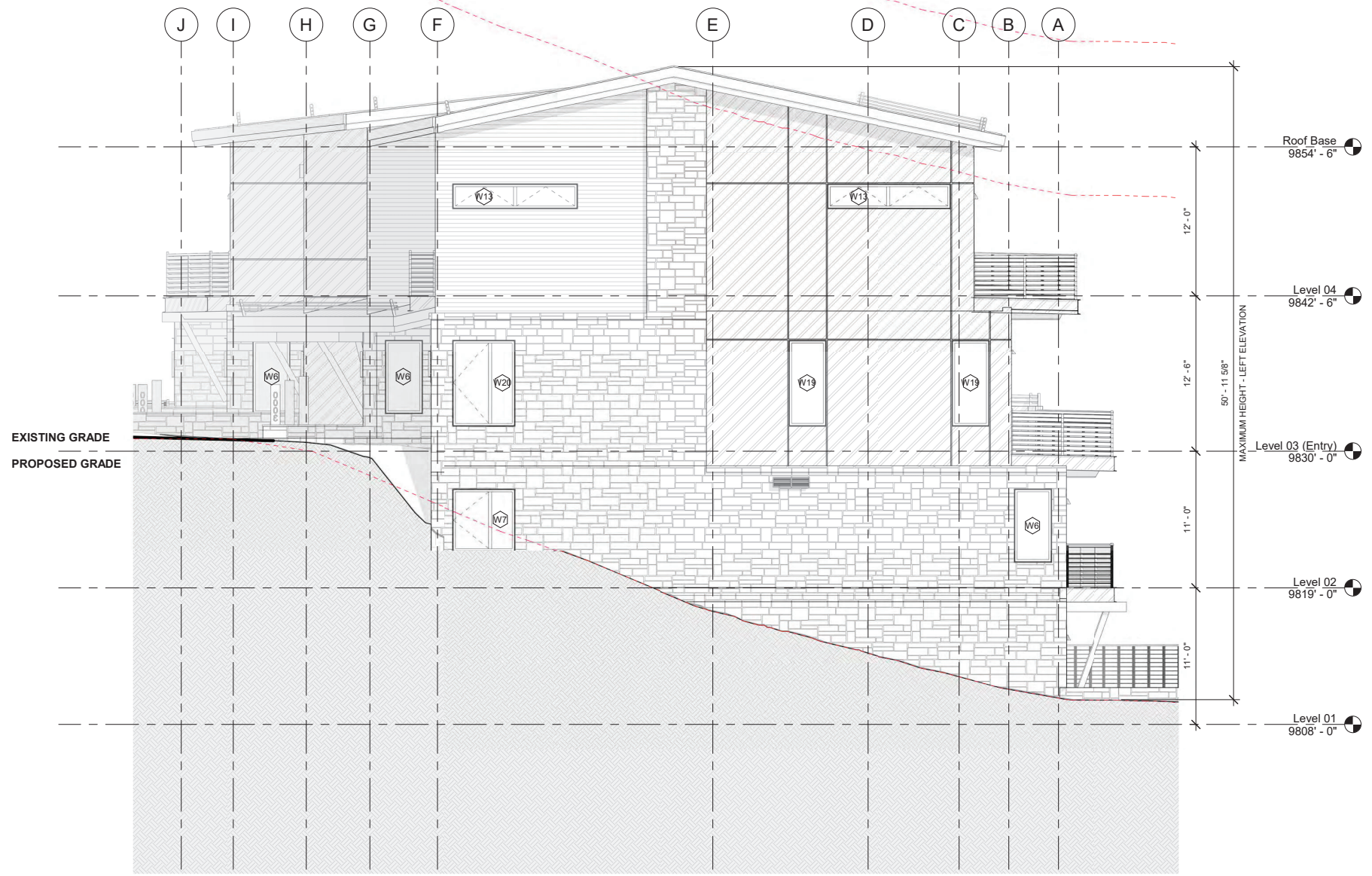

**1 LEFT ELEVATION - B&W**  
3/16" = 1'-0"

TOWN STAMP  
**359**  
DESIGN

348 HENNESSY CT SUITE 201  
DENVER, CO 80202  
720.512.3437



**LOT 165 CORTINA DRIVE**

Mountain Village, CO

No.	Description	Date

PROJECT NUMBER: 24102  
DATE: 10/28/2024

DRB PACKAGE

LEFT ELEVATION - B&W

**A2.08**

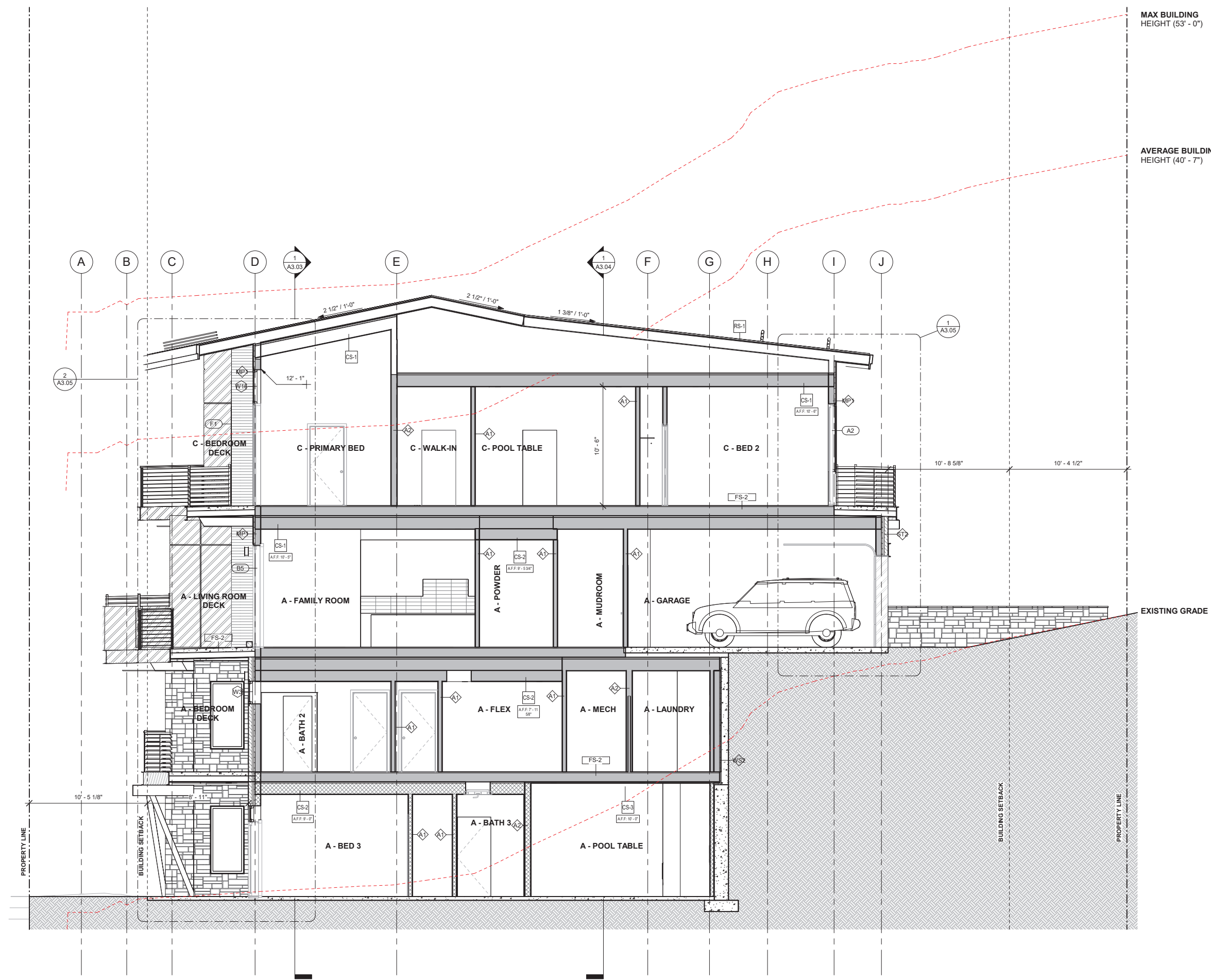

MAX BUILDING HEIGHT (53' - 0")

AVERAGE BUILDING HEIGHT (40' - 7")

**NOTE:**  
 GRAY HATCH INDICATES SYSTEMS BUILT SCOPE, TYP.  
 CROSSHATCH INDICATES PANELIZED SCOPE, TYP.

359  
 DESIGN

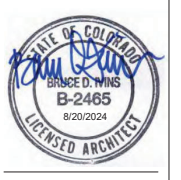

LOT 165 CORTINA DRIVE  
 Mountain Village, CO

No.	Description	Date

PROJECT NUMBER: 24192  
 SCALE DATE: 10/28/2024

DRB PACKAGE

BUILDING SECTION

A3.01

**1 BUILDING SECTION 1**  
 1/4" = 1'-0"

**NOTE:**  
 GRAY HATCH INDICATES SYSTEMS BUILT SCOPE, TYP.  
 CROSSHATCH INDICATES PANELIZED SCOPE, TYP.

MAX BUILDING HEIGHT (53' - 0")

AVERAGE BUILDING HEIGHT (40' - 7")

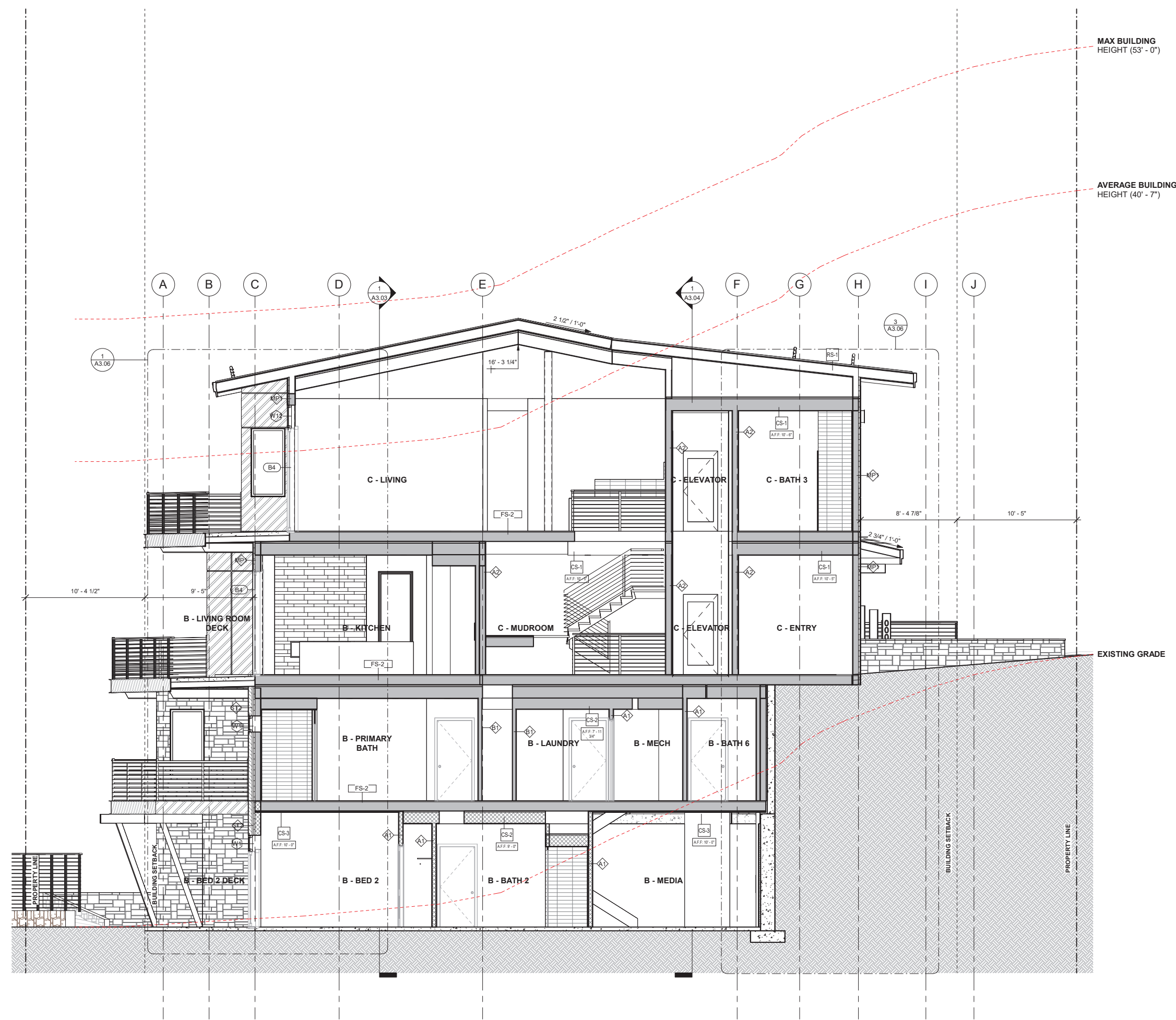

**359**  
 DESIGN

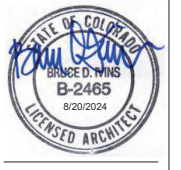

**LOT 165 CORTINA DRIVE**  
 Mountain Village, CO

No.	Description	Date

PROJECT NUMBER: 24102  
 SHEET DATE: 10/28/2024

**DRB PACKAGE**

**BUILDING SECTION**

**A3.02**

**1 BUILDING SECTION 2**  
 1/4" = 1'-0"

NOTE:  
 GRAY HATCH INDICATES SYSTEMS BUILT SCOPE, TYP.  
 CROSSHATCH INDICATES PANELIZED SCOPE, TYP.

359  
 DESIGN

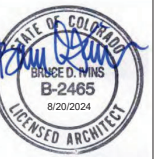

LOT 165 CORTINA DRIVE  
 Mountain Village, CO

No.	Description	Date

PROJECT NUMBER: 24102  
 TITLE DATE: 10/26/2024

DRB PACKAGE

BUILDING SECTION

SHEET NO.

A3.03

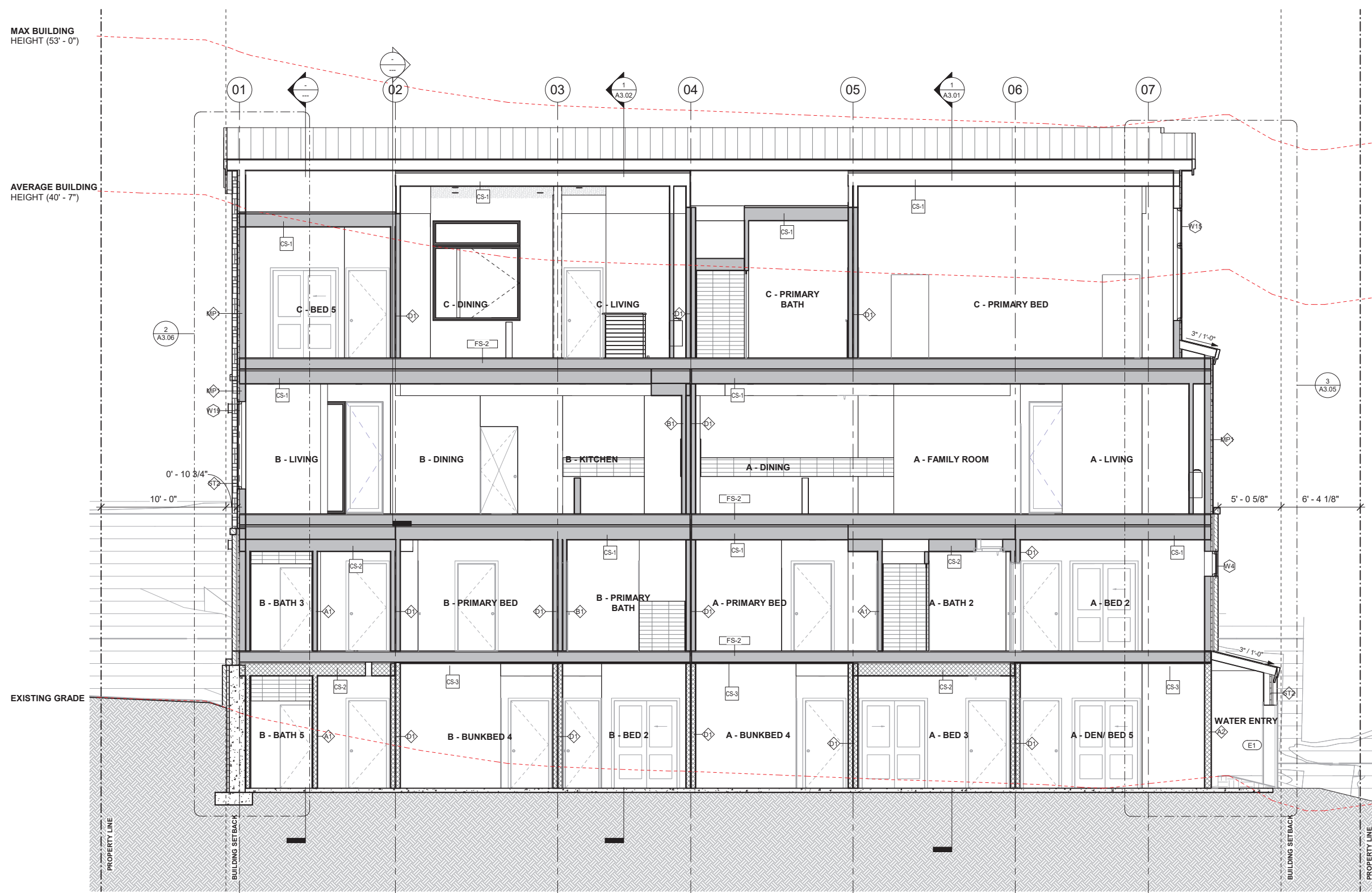

**1 BUILDING SECTION 3**  
 1/4" = 1'-0"

Window Schedule			
Type Mark	Width	Height	Operation
W1	7'-0"	1'-0"	FIXED
2			
W2	10'-0"	1'-0"	FIXED
2			
W3	6'-0"	2'-0"	FIXED
1			
W4	10'-0"	2'-0"	AWNING
1			
W5	3'-0"	5'-0"	FIXED
1			
W6	3'-0"	6'-0"	FIXED
6			
W7	5'-0"	5'-0"	FIXED + CASEMENT
1			
W8	7'-0"	5'-0"	FIXED + CASEMENT
2			
W9	2'-0"	9'-0"	FIXED
2			
W10	4'-0"	2'-0"	FIXED
1			
W11	5'-0"	2'-0"	FIXED
1			
W12	7'-0"	2'-0"	FIXED
3			

Window Schedule			
Type Mark	Width	Height	Operation
W13	10'-0"	2'-0"	AWNING
6			
W14	11'-3"	2'-0"	FIXED
1			
W15	6'-0"	3'-0"	FIXED
1			
W16	8'-0"	3'-0"	FIXED
1			
W17	9'-6"	3'-0"	FIXED
1			
W18	3'-0"	6'-0"	FIXED
5			
W19	3'-0"	7'-0"	FIXED
2			
W20	5'-0"	7'-0"	FIXED + CASEMENT
1			
W21	6'-0"	6'-0"	FIXED + CASEMENT
2			
W22	7'-0"	6'-0"	FIXED + CASEMENT
4			
W23	9'-6"	9'-0"	FIXED
1			
W24	7'-0"	9'-0"	FIXED
1			

INTERIOR DOOR SCHEDULE							
Type Mark	Width	Height	Operation	DOOR MATERIAL	Finish	Frame Material	Comments
U02	3'-0"	7'-0"	SWING	RIFT SAWN WHITE OAK			
U03	2'-10"	7'-0"	SWING	RIFT SAWN WHITE OAK			
U04	2'-8"	7'-0"	SWING	RIFT SAWN WHITE OAK			
U05	2'-6"	7'-0"	SWING	RIFT SAWN WHITE OAK			
U06	5'-0"	7'-0"	SLIDING	<varies>			
U07	3'-0"	6'-8"	POCKET				
U08	3'-7"	8'-0"	SLIDING	RIFT SAWN WHITE OAK			
U09	5'-0"	7'-0"	SWING				

EXTERIOR DOOR SCHEDULE										
Type Mark	Door Number	Level	Width	Height	Operation	DOOR MATERIAL	Finish	Frame Material	Comments	
A1	25	Level 01	3'-0"	8'-0"	SWING	METAL				
A1	40	Level 01	3'-0"	8'-0"	SWING	METAL				
A2	10	Level 03 (Entry)	3'-0"	9'-0"	SWING	METAL				
A2	11	Level 03 (Entry)	3'-0"	9'-0"	SWING	METAL				
A2	14	Level 03 (Entry)	3'-0"	9'-0"	SWING	METAL				
A2	19	Level 04	3'-0"	9'-0"	SWING	METAL				
A2	47	Level 04	3'-0"	9'-0"	SWING	METAL				
A2	49	Level 04	3'-0"	9'-0"	SWING	METAL				
B1	18	Level 01	10'-0"	8'-0"	SLIDER	METAL				
B1	31	Level 02	10'-0"	8'-0"	SLIDER	METAL				
B1	32	Level 02	10'-0"	8'-0"	SLIDER	METAL				
B1	33	Level 02	10'-0"	8'-0"	SLIDER	METAL				
B1	36	Level 02	10'-0"	8'-0"	SLIDER	METAL				
B2	6	Level 03 (Entry)	10'-0"	7'-0"	SLIDER	METAL				
B2	22	Level 03 (Entry)	10'-0"	7'-0"	SLIDER	METAL				
B2	43	Level 04	10'-0"	7'-0"	SLIDER	METAL				
B3	42	Level 03 (Entry)	11'-3"	9'-0"	SLIDER	METAL				
B3	46	Level 03 (Entry)	11'-3"	9'-0"	SLIDER	METAL				
B3	45	Level 04	11'-3"	9'-0"	SLIDER	METAL				
B4	7	Level 03 (Entry)	7'-0"	9'-0"	SLIDER	METAL				
B4	44	Level 04	7'-0"	9'-0"	SLIDER	METAL				
B5	41	Level 03 (Entry)	10'-0"	9'-0"	SLIDER	METAL				
B6	60	Level 01	7'-0"	6'-7 1/4"	SLIDER	METAL				
C1	59	Level 01	10'-0"	6'-7 1/4"	SLIDER	METAL				
C1	58	Level 01	10'-0"	6'-7 1/4"	SLIDER	METAL				
D1	50	Level 03 (Entry)	9'-0"	8'-0"	OVERHEAD DOOR	METAL				
D1	51	Level 03 (Entry)	9'-0"	8'-0"	OVERHEAD DOOR	METAL				
D1	52	Level 03 (Entry)	9'-0"	8'-0"	OVERHEAD DOOR	METAL				
E1	61	Level 01	3'-0"	6'-8"	SWING	METAL				
E1	62	Level 01	3'-0"	6'-8"	SWING	METAL				
F1	56	Level 04	7'-8"	8'-10"	ACCORDIAN	METAL				

### INTERIOR UNIT DOOR TYPES

### EXTERIOR BUILDING DOOR TYPES

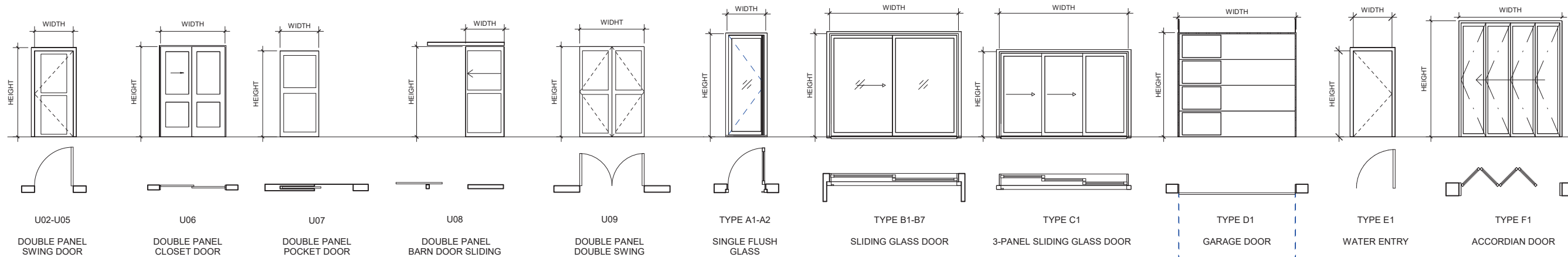

### BUILDING WINDOW TYPES

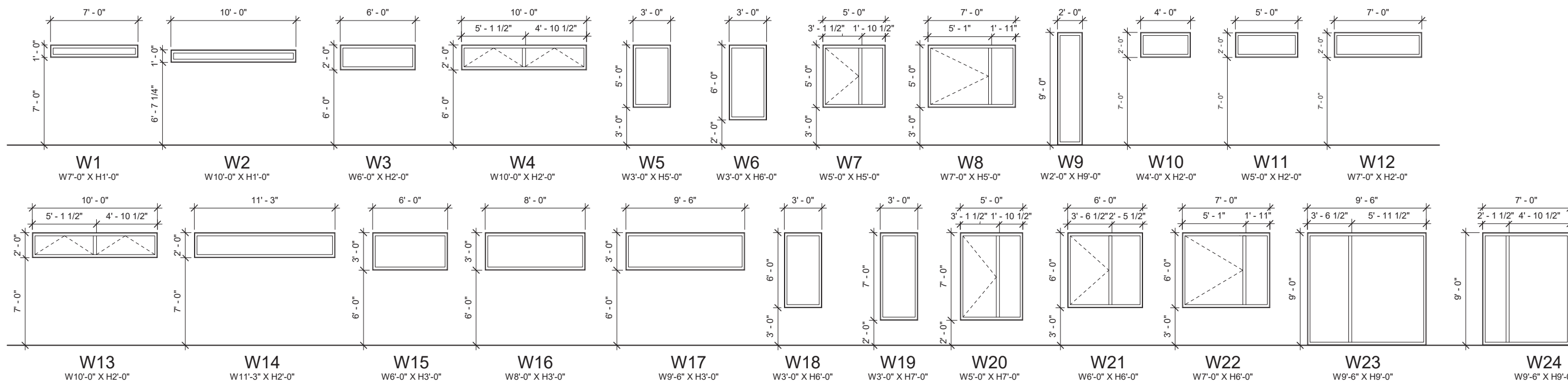

**359**  
DESIGN

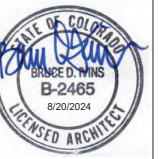

**LOT 165 CORTINA DRIVE**  
Mountain Village, CO

No.	Description	Date

PROJECT NUMBER: 24102  
SCALE DATE: 1/20/2024

DRB PACKAGE

WINDOW & DOOR SCHEDULE

**A5.01**



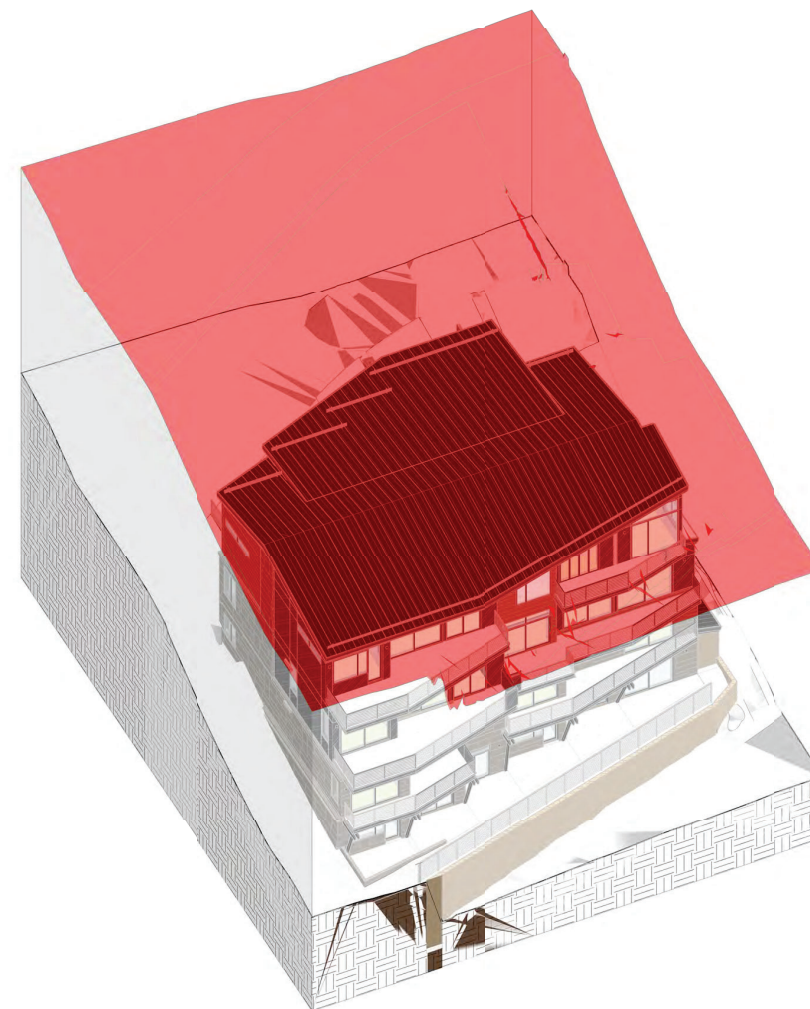
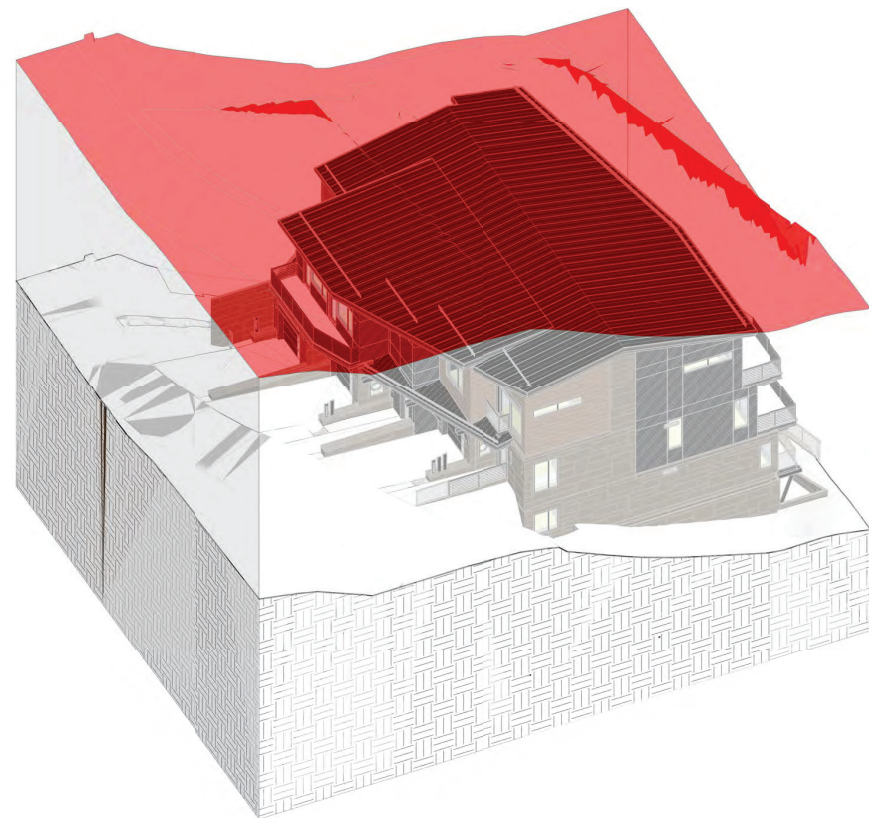
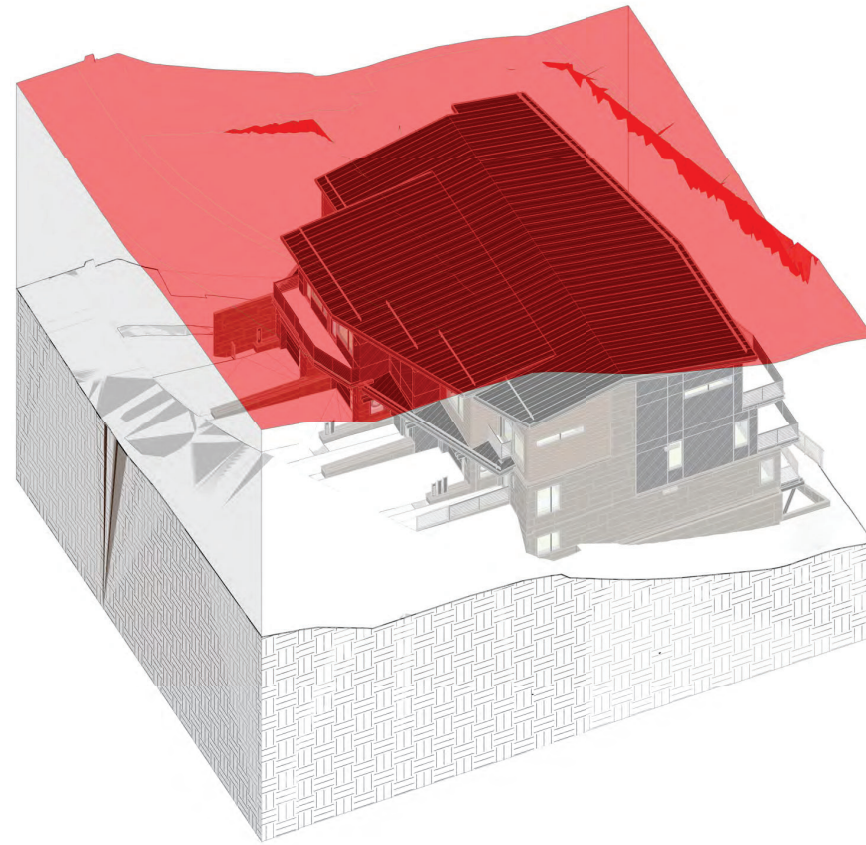
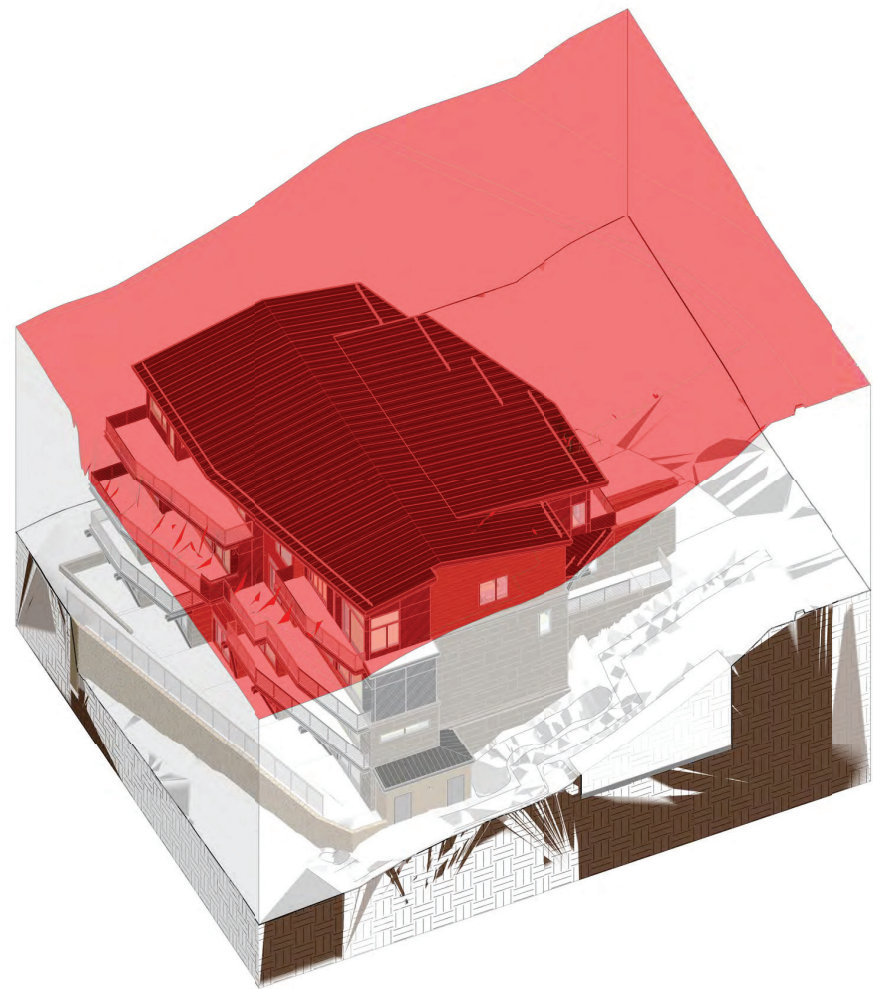

TOWN STAMP  
**359**  
 DESIGN

348 HENNESSY CT SUITE 201  
 DENVER, CO 80202  
 TEL 303.343.7777

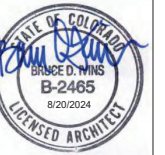

**LOT 165 CORTINA DRIVE**  
 Mountain Village, CO

REVISIONS

No.	Description	Date

PROJECT NUMBER: 24102  
 TITLE DATE: 10/28/2024

SCALE: DRB PACKAGE

SHEET TITLE: BUILDING HEIGHT REVIEW - EXISTING GRADING

SHEET NO:

**A9.00**

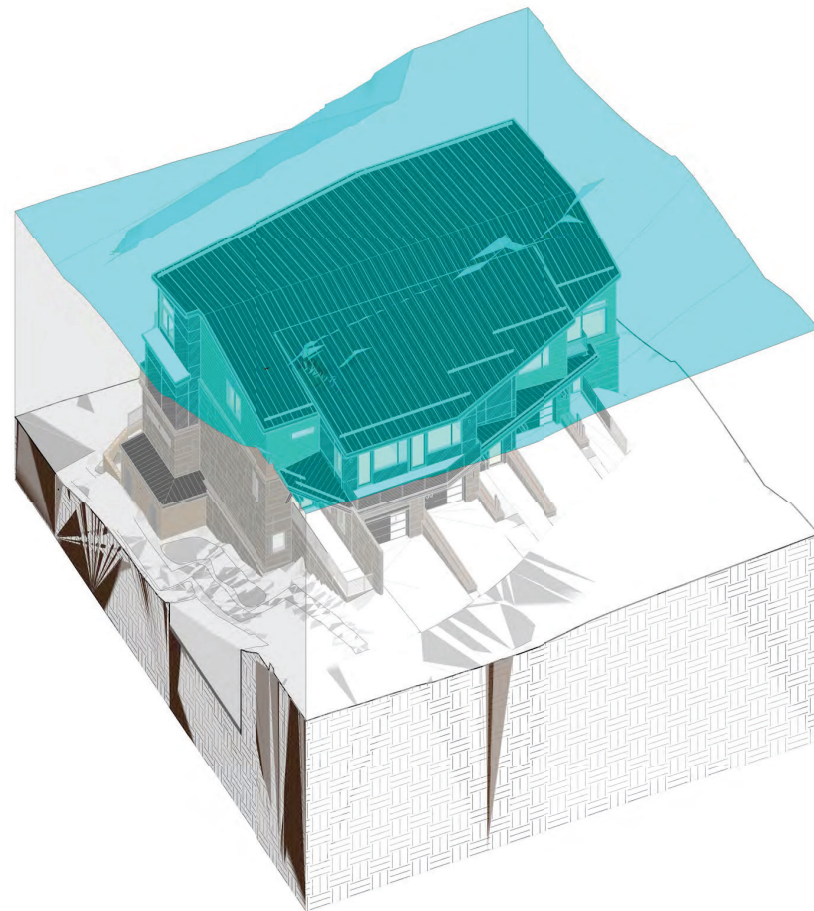
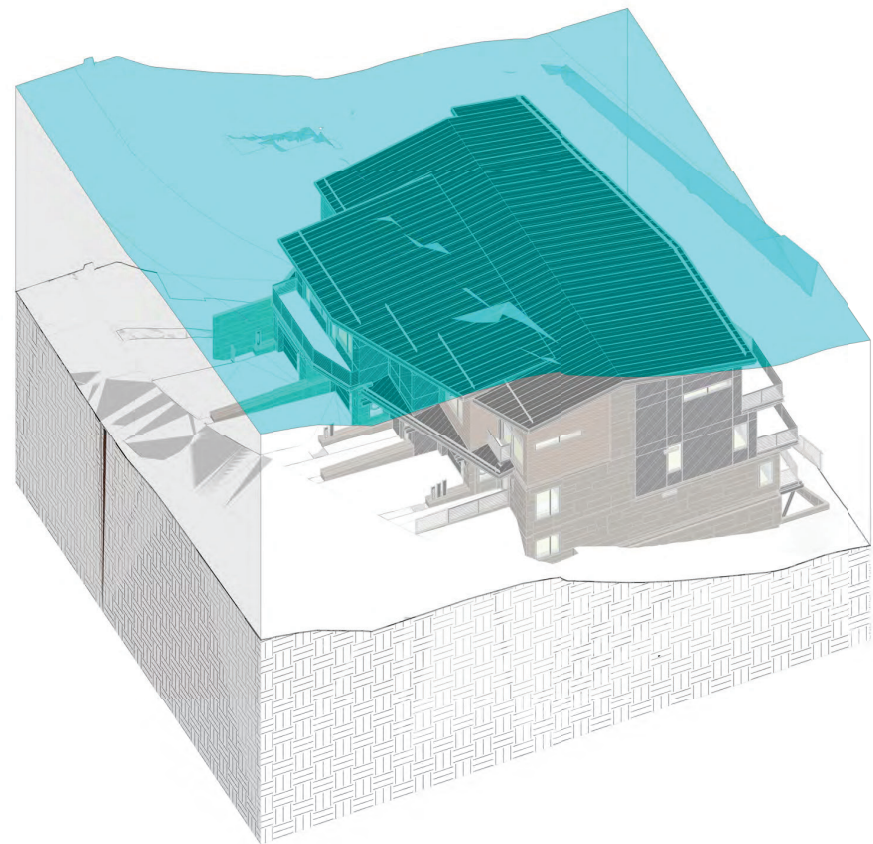
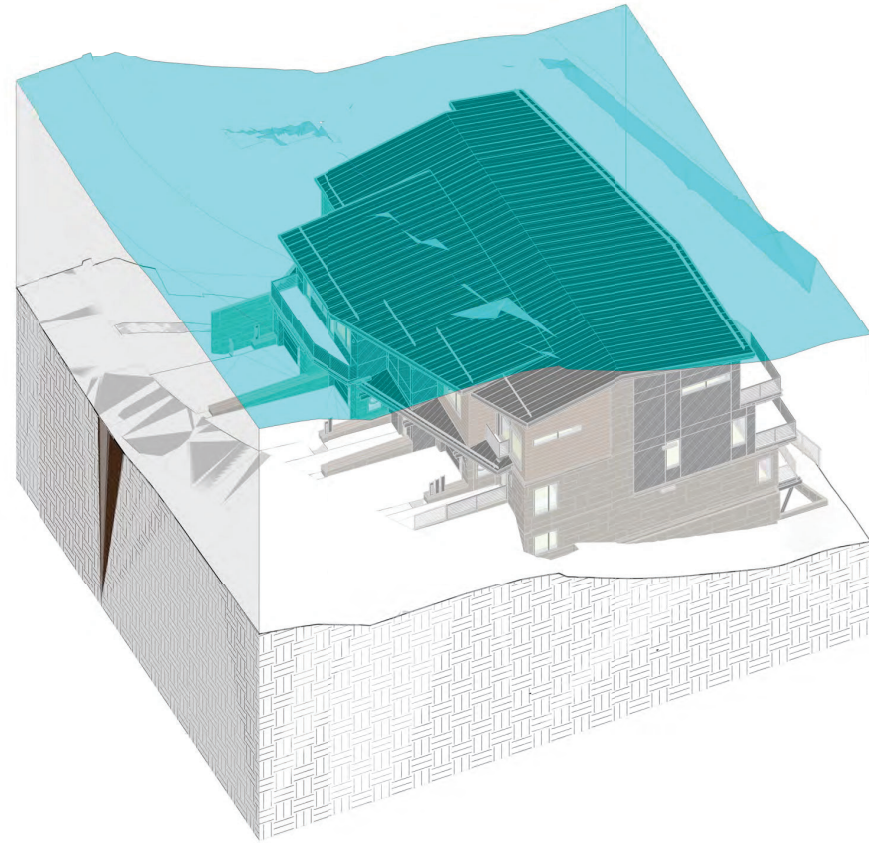
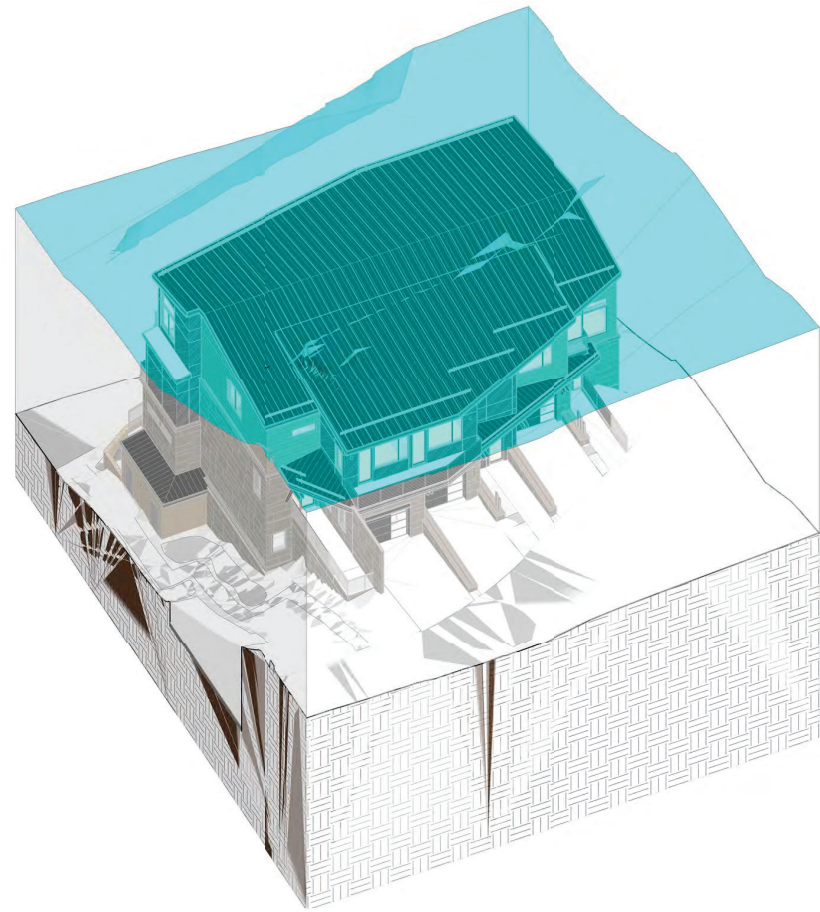

TOWN STAMP  
**359**  
 DESIGN

348 HENNESSY CT SUITE 201  
 DENVER, CO 80202  
 TEL 303.343.7777

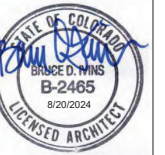

**LOT 165 CORTINA DRIVE**  
 Mountain Village, CO

REVISIONS

No.	Description	Date

PROJECT NUMBER: 24102  
 TITLE DATE: 10/28/2024

SCALE: DRB PACKAGE

SHEET TITLE: BUILDING HEIGHT REVIEW - PROPOSED GRADING

SHEET NO: **A9.01**

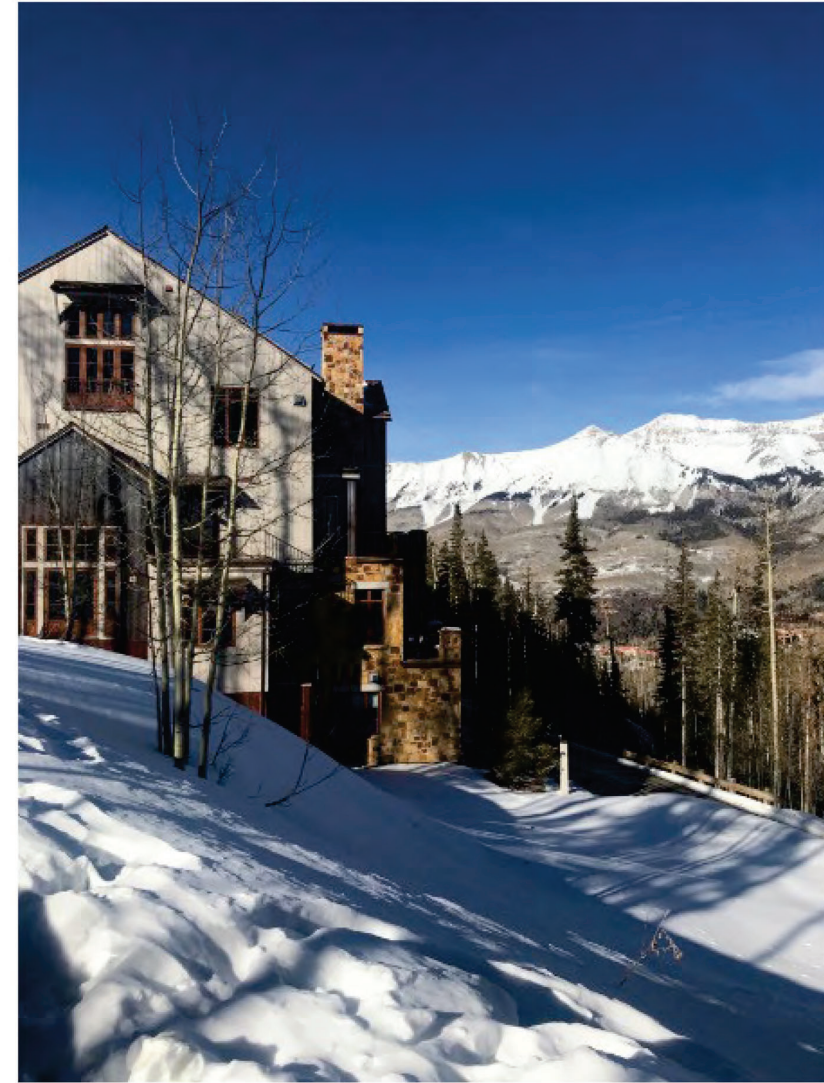

TOWN STAMP

**359**  
DESIGN

3485 HENNING CT SUITE 201  
DENVER, CO 80202  
720.312.3437

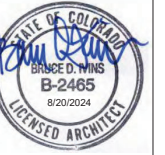

**LOT 165 CORTINA DRIVE**

Mountain Village, CO

REVISIONS

No.	Description	Date

PROJECT NUMBER: 24102

DATE: 10/28/2024

SCALE:

DRB PACKAGE

SHEET TITLE:

**SITE PHOTOS**

SHEET NO:

**A9.10**



TOWN STAMP

**359**  
DESIGN

348 RACSBY COURT SUITE 201  
DENVER, CO 80202  
TEL: 303.733.3437

**LOT 165 CORTINA DRIVE**

Mountain Village, CO

REVISIONS

No.	Description	Date

PROJECT NUMBER: 24192

DATE: 10/28/2024

**DRB PACKAGE**

**PERSPECTIVE VIEWS**

SHEET NO.

**A9.20**



TOWN STAMP

**359**  
DESIGN

3485 BRACKLEY COURT SUITE 201  
DENVER, CO 80202  
781.913.3437

**LOT 165 CORTINA DRIVE**

Mountain Village, CO

REVISIONS

No.	Description	Date

PROJECT NUMBER: 24192  
SCALE DATE: 1/28/2024

SCALE: **DRB PACKAGE**

SHEET TITLE: **PERSPECTIVE VIEWS**

SHEET NO: **A9.21**

No.	Description	Date

**DRB PACKAGE**  
**SURVEY**

I, Christopher R. Kennedy, being a Colorado Licensed Land Surveyor, do hereby certify that this Topographic Survey of Lot 165 was made by me and under my direct supervision, responsibility and checking. This Topographic Survey does not constitute a Land Survey Plat or Improvement Survey Plat as defined by Title 38, Article 51, C.R.S.



Christopher R. Kennedy, P.L.S. 36577

**NOTICE:**  
According to Colorado Law, you must commence any legal action based upon any defect in this survey within three years after you first discover such defect. In no event may any action based upon any defect in this survey be commenced more than ten years from the date of the certification shown hereon.

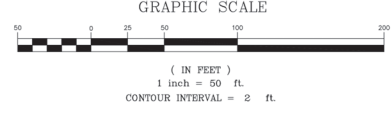
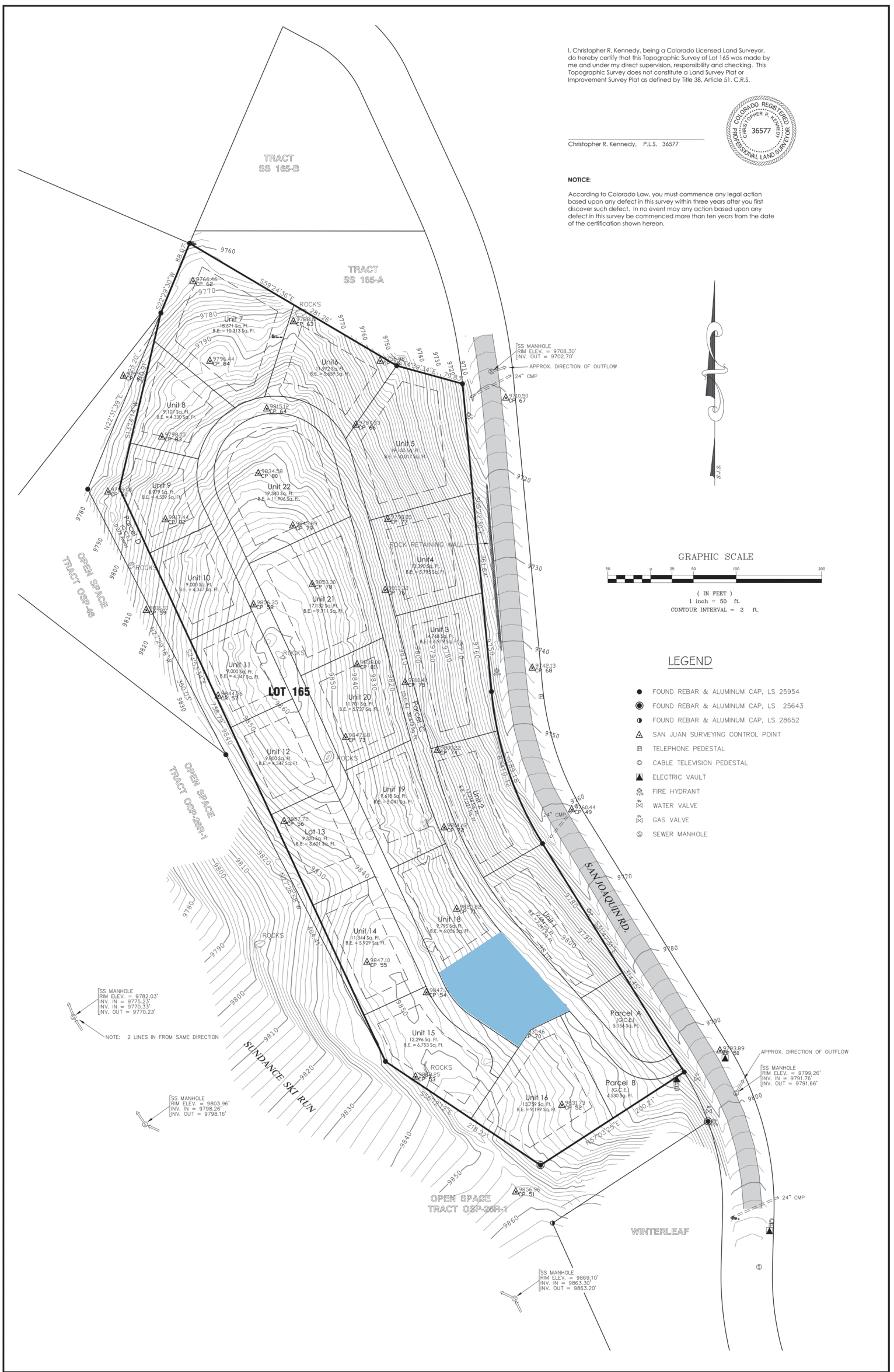

**LEGEND**

- FOUND REBAR & ALUMINUM CAP, LS 25954
- FOUND REBAR & ALUMINUM CAP, LS 25643
- FOUND REBAR & ALUMINUM CAP, LS 28652
- ▲ SAN JUAN SURVEYING CONTROL POINT
- TELEPHONE PEDESTAL
- CABLE TELEVISION PEDESTAL
- ▲ ELECTRIC VAULT
- FIRE HYDRANT
- WATER VALVE
- GAS VALVE
- SEWER MANHOLE

**CORTINA LAND CONDOMINIUMS WITH TOPO**  
**TOWN OF MOUNTAIN VILLAGE, COLORADO**

**SAN JUAN SURVEYING INC.**  
SURVEYING \* PLANNING  
160 D SOCIETY DRIVE TELLURIDE, CO. 81435  
(970) 728-1128 (970) 728-9201 fax  
SJS@TELLURIDECOLORADO.NET

DATE:	3/24/05
JOB:	04028
DRAWN BY:	JAL
CHECKED BY:	CRK
REVISION:	
DATES:	
SHEET:	1 OF 1

**1 SURVEY**  
1" = 60'-0"

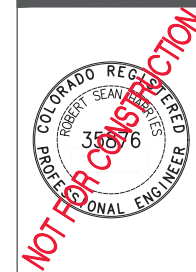

Goff Engineering & Surveying, Inc. expressly reserves the common law copyright and other property rights in these plans. These plans are not to be changed or copied in any form or manner whatsoever nor are they to be assigned to any third party without first obtaining written permission and consent of Goff Engineering & Surveying, Inc. ©

**LOT 165 CORTINA DRIVE**  
MOUNTAIN VILLAGE, CO

Issue Record:  
DRB PACKAGE 08-20-2024

Revisions:

Project Number: 24-142

Designed by: KHK  
Checked By: RSH

Sheet  
**C1.0**  
CIVIL PLAN

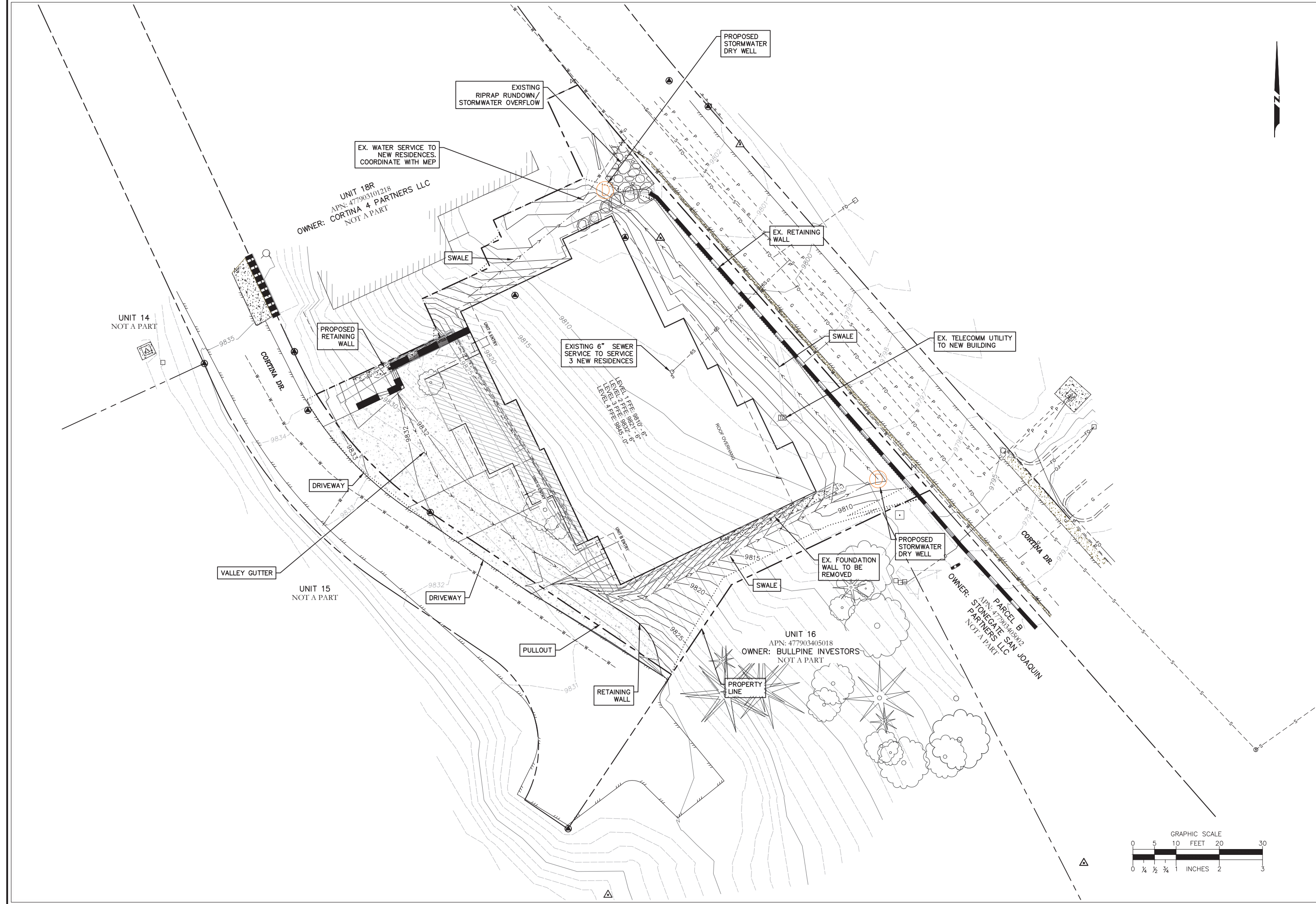

p:\2024\14-142\_telluride\_cortina\_residences\cort\plans\c1.dwg DATE: 8/20/2024 USER: RHARRIES PLOT SCALE=1:1

## Exhibit 03 – Access Easement – Variance Request

### Section 17.3.14 – General Easements Setbacks

C. All general easement setbacks or other setbacks shall be maintained in a natural, undisturbed state to provide buffering to surrounding land uses and to maintain the ability to conduct any of the general easement allowed uses.

D. All above-grade and below-grade structures or structural components (soil nailing, etc.), earth disturbance, or ground level site development such as walks, hardscape, terraces and patios shall be located outside of the general easement setback or other setbacks on each lot within the allowable building area of a lot.

Please refer to Images 01 – 02 below. The proposed development is requesting a design variance to encroach on the easement in the area noted. Per the ALTA survey provided in Exhibit 05, this easement is defined as a construction maintenance easement and pedestrian/skier easement (rec. no. 434255). The variance request is in conformance with CDC section 17.3.14.F.

Image 01 below highlights the two area of proposed easement encroachment within the overall site plan.

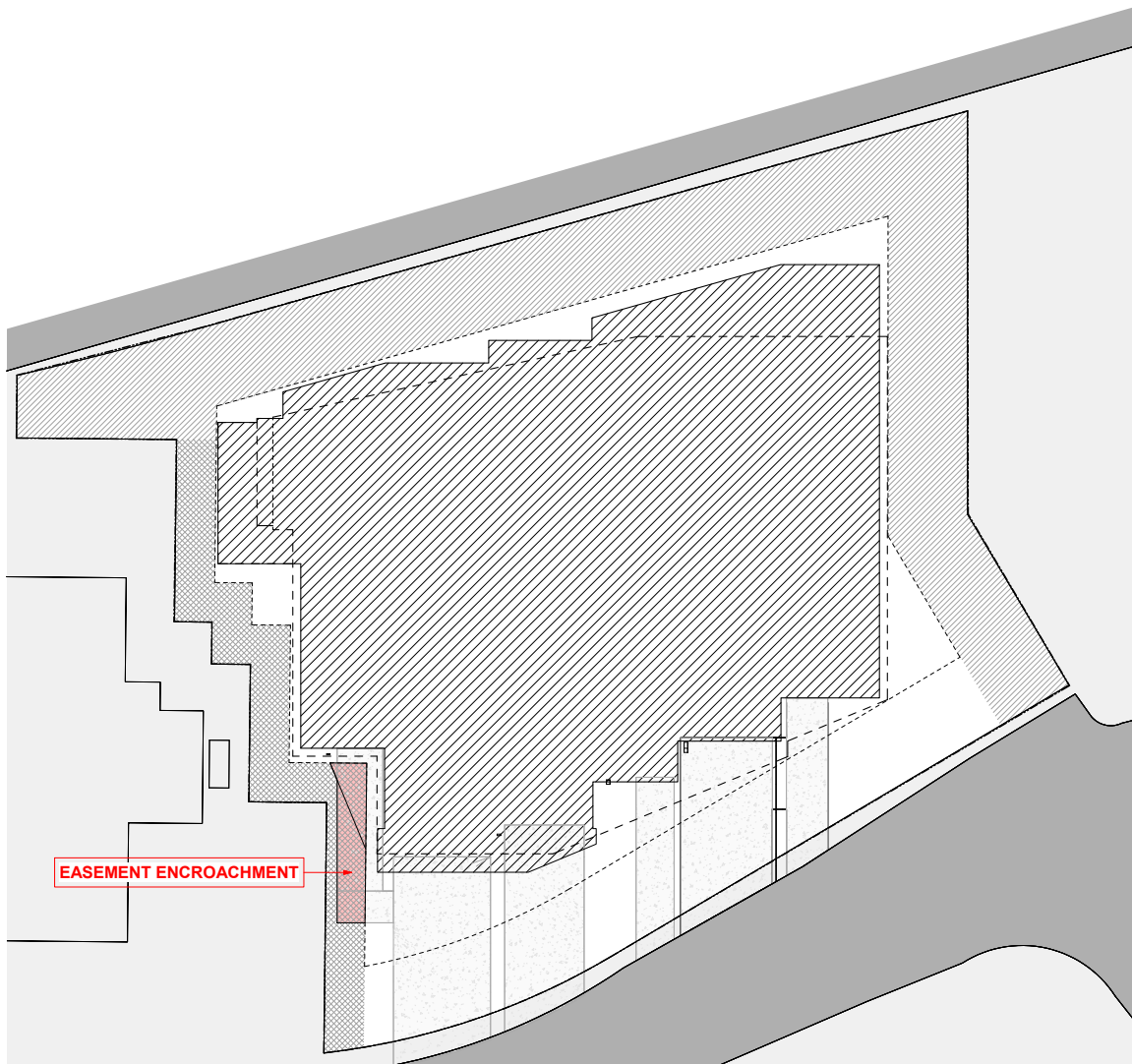
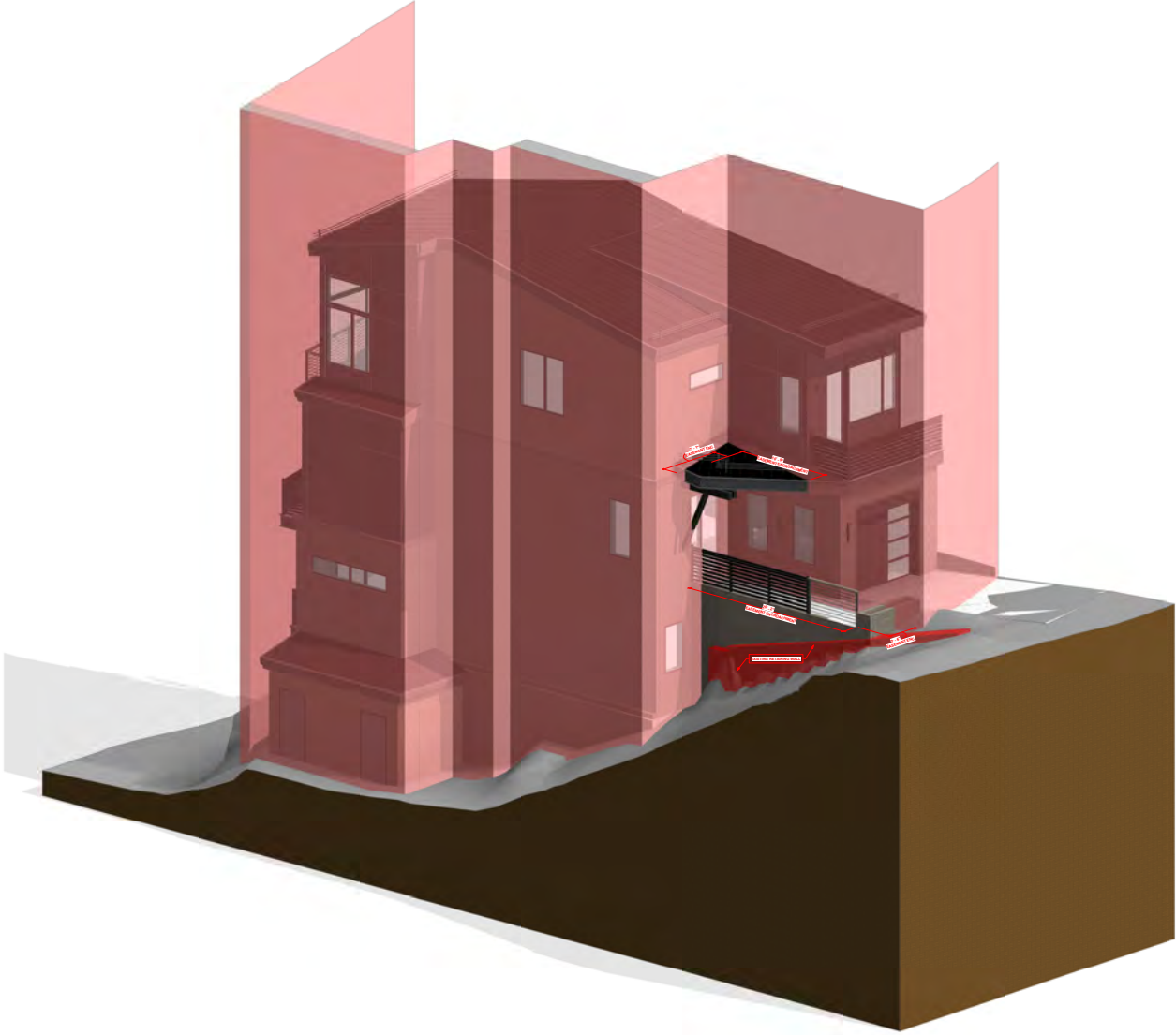

Image 01 – Easement proposed encroachment location



Image 02 below highlights the first proposed easement encroachment. The red footprint shown is representative of the project setback/easement boundary. As shown below and on the ALTA survey as provided in Exhibit 05, there is an existing foundation all that sits adjacent to the property line. The unit access as highlighted would be constructed to sit on top of this existing foundation wall, further incorporating it into the project. The entry roof reflects the overall character of the building and aligns with the unit entry below. As can be seen in image 01 of this exhibit, the proposed easement encroachment does not extend to the property line.



**Image 02 – Easement encroachment review**



AGENDA ITEM 5  
**COMMUNITY DEVELOPMENT DEPARTMENT**

455 Mountain Village Blvd.  
Mountain Village, CO 81435  
(970) 728-1392

**TO:** Mountain Village Design Review Board

**FROM:** Drew Nelson, Senior Planner

**FOR:** Design Review Board Public Hearing; November 7, 2024

**DATE:** October 30, 2024

**RE:** Staff Memo – Review and Recommendation by the Design Review Board regarding a Density Transfer and Rezone Application for Lot 908 per Community Development Code Sections 17.4.9 and 17.4.10

**APPLICATION OVERVIEW: Density Transfer and Rezone Application**

**PROJECT GEOGRAPHY**

**Legal Description:**

LOT 908, TELLURIDE MOUNTAIN VILLAGE, FILING 9, ACCORDING TO THE SUBSTANTIAL AMENDMENT TO LOT 903, LOT 908 AND TRACT OS-903 RECORDED DECEMBER 9, 1993 IN PLAT BOOK 1 AT PAGE 1602, COUNTY OF SAN MIGUEL, STATE OF COLORADO.

**Address:** TBD Victoria Drive

**Applicant/Agent:** Stephanie Fanos, attorney

**Owner:** 908 Associates, LLC

**Zoning:** Single-family

**Existing Use:** Vacant

**Proposed Use:** Passive Open Space

**Lot Size:** 0.895 acres

**Adjacent Land Uses:**

- **North:** Active Open Space
- **South:** Single Family Residence
- **East:** Vacant / Single Family Residence
- **West:** Vacant / Single Family Residence

**ATTACHMENTS**

Exhibit A: Narrative

Exhibit B: Staff/Public Comment

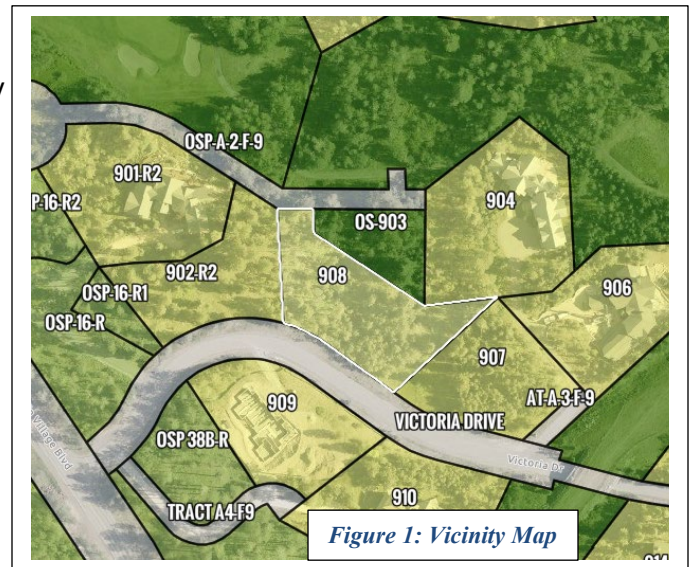

Figure 1: Vicinity Map

**Case Summary:** 908 Associates, LLC, represented by Stephanie Fanos, is the owner of Lot 908 and have applied for a Rezone and Density Transfer to create additional open space on Victoria Drive. The lot is currently vacant and has one unit of single-family equivalent density on it. It should be noted that the Design Review Board's purview in this application relates solely to the recommendation of the density transfer and rezone application

**Applicable CDC Requirement Analysis:** The applicable requirements cited may not be exhaustive or all-inclusive. The applicant is required to follow all requirements even if an applicable section of the CDC is not cited. ***Please note that Staff comments will be indicated by italicized Text.***

*Table 1*

	Existing Zoning Designations Built	Existing Zoning Designations Platted and unbuilt	Proposed Zoning Designations Built	Proposed Zoning Designations Platted and Unbuilt	Person Equivalents	Total Person Equivalents
Lot 908	0	1	0	0	4	0
Lot 908 To Density Bank				1	4	4
			<b>Total:</b>			<b>4</b>

*Staff: The proposal will result in a net decrease of one Single Family Unit of Density, or 4 person equivalents on Lot 908. The density will be transferred to the Density Bank and the owners will continue to pay any associated fees for this density.*

**CRITERIA, ANALYSIS AND FINDINGS**

The criteria for the decision to evaluate a rezone that changes the zoning designation and/or density allocation assigned to a lot is listed below. The following criteria must be met for the review authority to approve a rezoning application:

**CRITERIA, ANALYSIS, AND FINDINGS**

The criteria for the decision to evaluate a rezone that changes the zoning designation and/or density allocation assigned to a lot is listed below. The following criteria must be met for the review authority to approve a rezoning application:

**17.4.9: Rezoning Process**

3. Criteria for Decision:

- a. The proposed rezoning is in general conformance with the goals, policies, and provisions of the Comprehensive Plan;  
*Staff Finding: The applicant is requesting to rezone the property to Passive Open Space, which is a use contemplated in the general vicinity of Victoria Drive. The Comprehensive Plan’s Land Use Map also designates Victoria Drive as suitable for single-family development. With both Passive and Active Open Space in the vicinity or directly adjacent to this property, it appears to be in conformance with the Comprehensive Plan.*
- b. The proposed rezoning is consistent with the Zoning and Land Use Regulations.  
*Staff Finding: The proposed rezone and density transfer meets the requirements of the CDC. By reducing in the general vicinity of the property, the owners would be meeting the intent of the CDC. Further, Section 17.3.4.F.4 of the CDC specifically states that Single-Family lots may only be rezoned to the Passive Open Space District.*
- c. The proposed rezoning meets the Comprehensive Plan project standards;  
*The Comprehensive Plan project standards are listed as follows:*

1. Visual impacts shall be minimized and mitigated to the extent practical, while also providing the targeted density identified in each subarea plan development table. It is understood that visual impacts will occur with development.
2. Appropriate scale and mass that fits the site(s) under review shall be provided.
3. Environmental and geotechnical impacts shall be avoided, minimized and mitigated, to the extent practical, consistent with the Comprehensive Plan, while also providing the target density identified in each subarea plan development table.
4. Site-specific issues such as, but not limited to the location of trash facilities, grease trap cleanouts, restaurant vents and access points shall be addressed to the satisfaction of the Town.
5. The skier experience shall not be adversely affected, and any ski run width reductions or grade changes shall be within industry standards.

*Staff Finding: The proposed rezone and density transfer does not include any additional development, and therefore impacts to visual/scenic, environmental, geotechnical and ski resources are not anticipated.*

- d. The proposed rezoning is consistent with public health, safety and welfare, as well as efficiency and economy in the use of land and its resources;  
*Staff Finding: This neighborhood is a single-family zone and is being maintained as a single-family neighborhood with the addition of more passive open space. There should be a reduced impact to public health, safety and welfare through the reduction of transportation demand associated with less overall density in this neighborhood.*
- e. The proposed rezoning is justified because there is an error in the current zoning, there have been changes in conditions in the vicinity or there are specific policies in the Comprehensive Plan that contemplate the rezoning;  
*Staff Finding: The Future Land Use Map in the Comprehensive Plan identifies Lot 908 as a single-family residential lot. The neighborhood will continue to operate in a similar fashion, albeit with a reduction in density and impact.*
- f. Adequate public facilities and services are available to serve the intended land uses;  
*Staff Finding: Public facilities and services currently serve the existing development in the area. The proposed rezone and density transfer would reduce the need for services in this area.*
- g. The proposed rezoning shall not create vehicular or pedestrian circulation hazards or cause parking, trash or service delivery congestion; and  
*Staff Finding: The rezoning will not create vehicular or pedestrian circulation hazards. There will be an overall reduction in curb cuts and vehicular movements through the reduction in the density on the lot.*

- h. The proposed rezoning meets all applicable Town regulations and standards.

*Staff Finding: The application meets all applicable regulations and standards.*

#### **17.4.10: Density Transfer Process**

##### D. Criteria for Decision

2. Class 4 Applications. The following criteria shall be met for the Review Authority to approve a density transfer.

- a. The criteria for decision for rezoning are met since such density transfer must be processed concurrently with a rezoning development application (except for MPUD development applications);

*Staff Finding: The applicant has met the criteria for the decision for rezoning as provided above.*

- b. The density transfer meets the density transfer and density bank policies; and.

*Staff Finding: The application meets all applicable density transfer and density bank policies. The applicant is proposing to transfer existing density into the density bank.*

- c. The proposed density transfer meets all applicable Town regulations and standards.

*Staff Finding: The application meets all applicable regulations and standards.*

#### **DESIGN REVIEW BOARD CRITERIA FOR REVIEW:**

The Design Review Board's purview relates specifically to how density transfers and rezone applications may have design-related implications. The DRB must determine if the proposal to rezone this single-family lot and transfer the density to the Density Bank meets the intent of the CDC and other applicable standards.

***Staff Note: It should be noted that reasons for approval or rejection should be stated in the findings of fact and motion.***

**RECOMMENDATION:** If the DRB determines that the application for a Density Transfer and Rezone of Lot 908 meets the criteria for decision listed within this staff memo, then staff has provided the following suggested motion:

*I move to recommend approval to the Town Council an Ordinance regarding the Density Transfer and Rezone application, pursuant to CDC Sections 17.4.9 & 17.4.10 of the Community Development Code, to rezone Lot 908 from Single-Family to Passive Open Space and transfer 1 single-family density unit (4-person equivalent density) to the density bank based on the evidence provided within the staff report of record dated October 30, 2024, and with the following conditions:*

1. *The owner of record of density in the density bank, shall be responsible for all dues, fees, and any taxes associated with the assigned density and zoning until such time as the density is either transferred to a lot or another person or entity.*



## REZONING/DENSITY TRANSFER APPLICATION

**Planning & Development Services**  
 455 Mountain Village Blvd.  
 Mountain Village, CO 81435  
 970-728-1392  
 970-728-4342 Fax  
 cd@mtnvillage.org

Revised 1.3.2020

REZONING/DENSITY TRANSFER APPLICATION			
APPLICANT INFORMATION			
<b>Name:</b> STEPHANIE L FANOS, ESQ		<b>E-mail Address:</b> STEPHANIE@FANOSLEGAL.COM	
<b>Mailing Address:</b> POB 3600		<b>Phone:</b> 970.728.1861	
<b>City:</b> TELLURIDE	<b>State:</b> CO	<b>Zip Code:</b> 81435	
<b>Mountain Village Business License Number:</b> 00186			
PROPERTY INFORMATION			
<b>Physical Address:</b> LOT 908		<b>Acreage:</b> 0.896	
<b>Zone District:</b> SINGLE FAMILY	<b>Zoning Designations:</b> SINGLE FAMILY	<b>Density Assigned to the Lot or Site:</b> 1 SINGLE FAMILY UNIT	
<b>Legal Description:</b> LOT 908			
<b>Existing Land Uses:</b> SINGLE FAMILY			
<b>Proposed Land Uses:</b> PASSIVE OPEN SPACE			
OWNER INFORMATION			
<b>Property Owner:</b> 908 ASSOCIATES LLC		<b>E-mail Address:</b> Friedmanfamilyinvestments@gmail.com	
<b>Mailing Address:</b> 2028 E BEN WHITE BLVD		<b>Phone:</b> 516-848-5660	
<b>City:</b> AUSTIN	<b>State:</b> TEXAS	<b>Zip Code:</b> 78741	
DESCRIPTION OF REQUEST			
REZONE LOT 908 FROM SINGLE FAMILY TO PASSIVE OPEN SPACE. TRANSFER ONE (1) SINGLE FAMILY UNIT OF DENSITY TO TOWN OF MOUNTAIN VILLAGE DENSITY BANK SEE NARRATIVE			

**LOT 908**

**REZONE AND DENSITY TRANSFER APPLICATION**

**OWNER:** 908 ASSOCIATES, LLC

**LEGAL DESCRIPTION:** LOT 908, TELLURIDE MOUNTAIN VILLAGE, FILING 9, ACCORDING TO THE SUBSTANTIAL AMENDMENT TO LOT 903, LOT 908 AND TRACT OS-903 RECORDED DECEMBER 9, 1993 IN PLAT BOOK 1 AT PAGE 1602, COUNTY OF SAN MIGUEL, STATE OF COLORADO.

**ACREAGE:** 0.895 acres (as measured per Improvement Survey Plat certified on February 12, 2021); 0.896 acres per plat recorded at Reception No. 289064

**CURRENT ZONING:** SINGLE FAMILY

**CURRENT USE:** VACANT

**PROPOSED ZONING:** PASSIVE OPEN SPACE

**DENSITY TRANSFER TO DENSITY BANK:** One (1) single-family unit of density (4 persons) to be held in the Town of Mountain Village Density Bank by 908 Associates, LLC.

---

908 ASSOCIATES, LLC proposes to rezone Lot 908 from Single-Family to Passive Open Space and to transfer one (1) single-family unit of density (4 persons) to the Town of Mountain Village Density Bank.

Lot 908 is located in the Single-Family Zone District accessed off of Victoria Drive. See attached map. Lot 908 is adjacent to: (i) two vacant single-family lots, Lot 902-R2 and Lot 907; ) (ii) Active Open Space Tract 903; and (iv) single-family Lot 904, which has been improved with a single-family residence. 908 Associates, LLC is jointly owned by the owners of Lot 902R-2 and Lot 904.

**CRITERIA FOR REZONING APPLICATION (CDC Section 17.4.9(C)(3):**

a. The proposed rezoning is in general conformance with the goals, policies and provisions of the Comprehensive Plan;

*Rezoning from Single Family to Passive Open Space is consistent with the Single-Family land use principles and policies set forth in the Comprehensive plan as it preserves the character of existing low-density residential areas by reducing density and protects the natural open space and wildlife habitat in this single-family neighborhood.*

b. The proposed rezoning is consistent with the Zoning and Land Use Regulations;

*CDC Section 17.3.4(F)(4) specifically contemplates that Single Family Lots may be rezoned to Passive Open Space (“Single-family lots may only be rezoned to the Passive Open Space District.”)*

- c. The proposed rezoning meets the Comprehensive Plan project standards;

*Rezoning from Single Family to Passive Open Space is consistent with the Single-Family land use principles and policies set forth in the Comprehensive plan as it preserves the character of existing low-density residential areas by reducing density and protects the natural open space and wildlife habitat in this single-family neighborhood.*

- d. The proposed rezoning is consistent with public health, safety and welfare, as well as efficiency and economy in the use of land and its resources;

*Rezoning from Single Family to Passive Open Space reduces the impacts to and use of the land by downzoning to Passive Open Space and reducing density, thereby reducing the impacts to this single-family neighborhood.*

- e. The proposed rezoning is justified because there is an error in the current zoning, there have been changes in conditions in the vicinity or there are specific policies in the Comprehensive Plan that contemplate the rezoning;

*Rezoning from Single Family to Passive Open Space increases the total Passive Open Space acreage required in the Town under the Comprehensive Plan, the CDC and the 1999 Settlement Agreement between the Town and San Miguel County. CDC Section 17.3.4(F)(4) specifically contemplates the rezoning of Single-family lots to Passive Open Space. (“Single-family lots may only be rezoned to the Passive Open Space District.”)*

- f. Adequate public facilities and services are available to serve the intended land uses;

*Rezoning from Single Family to Passive Open Space bank reduces the need for public facilities and services by reducing density.*

- g. The proposed rezoning shall not create vehicular or pedestrian circulation hazards or cause parking, trash or service delivery congestion; and

*Rezoning from Single Family to Passive Open Space reduces the need for public facilities and services by reducing density, thereby decreasing vehicular and pedestrian parking and trash and delivery services.*



- h. The proposed rezoning meets all applicable Town regulations and standards.

*Rezoning from Single Family to Passive Open Space consistent with all applicable Town regulations and standards. CDC Section 17.3.4(F)(4) specifically contemplates the rezoning of Single-family lots to Passive Open Space. ("Single-family lots may only be rezoned to the Passive Open Space District.")*

**Criteria for Density Transfer Application CDC Section 17.4.10(2)**

- 2. *Class 4 Applications.* The following criteria shall be met for the Review Authority to approve a density transfer:

- a. The criteria for decision for a rezoning are met, since such density transfer must be processed concurrently with a rezoning development application (except for MPUD development applications);

*See above*

- b. The density transfer meets the density transfer and density bank policies; and

*See above*

- c. The proposed density transfer meets all applicable Town regulations and standards.

*See above*

**Rezoning and Density Transfer Ordinance.**

Pursuant to the CDC Section 17.4.9(D)(2)(b), "If the current, recorded plat for the lot(s) affected by the rezoning lists either the zone district, zoning designation and/or associated density, the rezoning ordinance shall include a statement that the zoning set forth in the rezoning ordinance shall prevail over any inconsistent plat notations on all validly recorded plats for the lots affected by such rezoning.

908 Associates, LLC requests that the Ordinance approving this Rezone and Density Transfer Application contain the following statement: ***"The zoning set forth in this rezoning ordinance shall prevail over any inconsistent plat notations on all validly recorded plats for the lots affected by such rezoning."***

